



Oregon State University

REQUEST FOR PROPOSAL (RFP) NO. 2025-017758

Master Contract for Forest Road Infrastructure

ISSUE DATE: January 23, 2025

NON-MANDATORY PRE-PROPSAL CONFERENCE

February 4, 2025 at 11:00 AM Pacific Time (PT)
at the Research Forests Office, located at 8692 Northwest Peavy
Arboretum Road, Corvallis, Oregon 97330

RFP DUE DATE/TIME:

February 25, 2025 at 3:00 PM Pacific Time (PT)
via electronic submission to Bids@oregonstate.edu

QUESTION DEADLINE: February 11, 2025 at 4:00 PM Pacific Time (PT)

CONTRACT ADMINISTRATOR:

Shoshana Shabazz, Purchasing Analyst
Construction Contracts Administration
Oregon State University
644 SW 13th Street
Corvallis, Oregon 97333

Email: constructioncontracts@oregonstate.edu

APPEALS:

Hanna Emerson-Steed, Director & Chief Procurement Officer
Procurement, Contracts and Materials Management (PCMM)
Oregon State University
644 SW 13th Street
Corvallis, Oregon 97333

Email: hanna.emerson@oregonstate.edu

Failure to acknowledge any Addenda in the Transmittal Letter may cause your Proposal to be considered non-responsive.

OSU standards and policies govern this solicitation ([Procurement Thresholds and Methods](#), [Procurement Solicitations and Contracts](#)) unless otherwise referenced or stated.

1.0 INTRODUCTION

1.1 Oregon State University (OSU) is conducting a competitive one-step RFPs to retain one (1) contractor to provide forest road infrastructure services on OSU's College Forests statewide. OSU at the discretion of OSU, may elect to retain an additional contractor for road infrastructure services in Columbia and Multnomah Counties. Forest road infrastructure services are required for the on-going management of the forest road network for harvest related activities, compliance with Oregon Department of Forestry (ODF) Forest Practices Act, and addressing storm and natural process related work. It is anticipated that eighty (80) percent of the work will occur in Benton County on the McDonald Dunn tract. It is estimated about ten (10) percent will occur in Columbia County on the Blodgett Tract, and another ten (10) percent will occur on the remaining satellite forest tracts throughout the State

Firms interested in providing these services to OSU may submit a proposal in response to the RFP.

Historically, OSU has issued long term Forest Road Maintenance contracts for various forest road maintenance and special project work. The most recent contract expires March 31, 2025 and was in excess of \$1,000,000.00 over the course of five (5) years.

OSU at the discretion of OSU will award to provide services based on the needs of OSU. Proposers are advised that OSU **will not** guarantee that any work or any specific volume of work will be awarded to a successful Proposer.

OSU WILL ONLY BE ACCEPTING SEALED PROPOSALS ELECTRONICALLY - Proposals are to be submitted to Bids@oregonstate.edu by the Due Date/Time.

NON-MANDATORY PRE PROPOSAL CONFERENCE – Non-Mandatory Pre Proposal Conference shall take place February 4, 2025 at 11:00 AM Pacific Time (PT) at the Research Forests Office, located at 8692 Northwest Peavy Arboretum Road, Corvallis, Oregon 97330.

- Directions <https://maps.app.goo.gl/Bd7wKkXHXmX8JZxAA>
- **Directions from Monmouth:**
Head South on OR 99W (Pacific Highway West) for 12.8 miles, turn right onto Northwest Arboretum Road and continue for 0.8 miles, turn right onto Northwest Peavy Arboretum Road and continue for 0.5 miles to Research Forests Office.
- **Directions from Corvallis:**
Head North on OR 99W (Pacific Highway West) for 5.6 miles, turn left onto Northwest Arboretum Road and continue for 0.8 miles, turn left onto Northwest Peavy Arboretum Road and continue for 0.5 miles to Research Forests Office.
- **Directions from Albany:**
Head West on US-20W (United States Highway No. 20 West) for 4.1 miles, turn right onto Northwest Independence Highway and continue for 2.5 miles, turn left onto Northwest Ryals Avenue and continue for 1.4 miles, turn left to stay on Northwest Ryals Avenue and continue for 0.9 miles, continue straight across OR 99W (Pacific Highway West) onto Northwest Arboretum Road for 0.8 miles, turn right onto Northwest Peavy Arboretum Road and continue for 0.5 miles to Research Forests Office.

All questions shall be submitted via e-mail to constructioncontracts@oregonstate.edu by the Question Deadline in order to be addressed. **The email subject line should contain the Solicitation Number/Name and Firm Name. OSU will not be responsible for missed RFP responses/questions/clarifications because the naming convention above was not used.**

1.2 Background. Oregon State University in Corvallis, Oregon is located within the traditional homelands of the Mary's River or Ampinefu Band of Kalapuya. Following the Willamette Valley Treaty of 1855 (Kalapuya etc. Treaty), Kalapuya people were forcibly removed to reservations in Western Oregon. Today, living descendants of these people are a part of the Confederated Tribes of Grand Ronde Community of Oregon (<https://www.grandronde.org>) and the Confederated Tribes of the Siletz Indians (<https://ctsi.nsn.us>).

Founded in 1868 as Oregon's land grant institution, OSU serves the state, the nation and the world as a premier 21st-century research university. OSU is committed to exceptional research, discovery, innovation and engagement — and to integrating its research and engagement mission with the delivery of a high-quality, globally relevant and affordable education for the people of Oregon and beyond. OSU is one of only two land, sea, space and sun grant universities in the U.S. and is the only university in Oregon to have earned both Carnegie Classifications for Very High Research Activity and Community Engagement.

The university's 570-acre main campus is located in the city of Corvallis, a vibrant college town of nearly 58,000 in the heart of Western Oregon's Willamette Valley. Corvallis consistently ranks among the safest, most highly educated and greenest small cities in the nation.

1.3 Location. OSU Research Forests ("OSURF") manages forest tracts throughout the State of Oregon, including:

- Benton County: McDonald Dunn, Cameron, Marchel;
- Columbia County: Blodgett;
- Washington County: Matteson;
- Clackamas County, Ram's Dell;
- Jackson County: Collins;
- Union County: Oberteuffer

OSURF is occasionally gifted or otherwise acquires forest tracts, therefore, more project locations and work may be added. Also given the distance to some of the forest tracts from Benton County, OSURF reserves the right, but not the obligation to contract with other providers for work otherwise covered by this agreement.

1.4 Summary of Work. Forest road infrastructure services **for OSU forest statewide.**

The attached **Sample Master Contract (Exhibit 1)** contains contract terms and conditions applicable to the work, and will form the basis of the final contract. The Sample Master Contract may contain certain notes or alternative provisions. Those alternative provisions will be included at the sole discretion of OSU. OSU will use the July 1, 2019 OSU General Conditions Master Contract for Construction Related Services (**OSU General Conditions**) as the basis for the final agreement. The OSU General Conditions shall apply to the work of all subcontractors, if any and to the work of the Contractor to the extent that they do not conflict with the Master Contract.

All Proposers must be registered and licensed with the Oregon Construction Contractors Board (CCB) and have on file with the CCB the public works bond as required by Oregon Laws 2005, Chapter 350 and OAR 839-025-015, unless otherwise exempt under those provisions, prior to submitting proposals. Failure to be licensed and have the bond in place will be sufficient cause to reject proposals as non-responsive. Additionally, all Proposers must also be certified as an Oregon Professional Logger (OPL) by the Association of Oregon Loggers (AOL), prior to submitting proposals. Failure to be certified will be sufficient cause to reject proposals as non-responsive. **A valid copy of the AOL OPL must accompany all Proposers proposals.**

Individual scopes of work (**Plan of Work**) will require a cost proposal and be subject to approval by the OSURF Project Manager (**Project Manager**). Cost proposal for work shall be submitted within three business days of request and approval will be confirmed through the issuance of a purchase order by the Construction Contracts Administration department prior to Work commencing.

1.5 Scope of Services. The successful Proposer will agree to provide construction related services, including labor, equipment and materials for various OSURF projects in OSURF, statewide. Until the Contract is amended, there is no guarantee or promise of work. After the initial amendment, the Contract may be subsequently amended to include additional, anticipated work as described below. These infrastructure investments are intended to maintain on-going forest management, comply with ODF regulations, and storm and natural related processes.

Services could generally include:

- Water quality and fish passage road crossing upgrades
- Re-opening or construction of dirt and rocked spur roads for timber harvest access
- Maintenance of roadway, ditches, and structures
- Post-harvest road rocking, grading and rolling
- Culvert replacement and upgrades
- Road template repairs and stabilization
- Roadside brushing
- Emergency winter repairs or mitigation

For each Plan of Work, the successful Proposer will:

- Coordinate with Project Manager
- Attend site visit(s), if required by Project Manager
- Provide recommendations and revisions to the scope of work based on Proposers practical experience in forest road infrastructure, construction and horizontal earthwork projects, if applicable.
 - Revisions to the scope must be approved by the Project Manager
- Provide estimates for specific work upon request from Project Manager within three (3) business days (for standard work orders), unless otherwise stated by Project Manager.
 - All estimates must contain a detailed cost breakdown, showing cost per unit (as identified in Contract)
- Initiate Kick-Off Meeting
 - Successful Proposer shall organize a Plan of Work Kick-Off meeting after Purchase Order is issued by the Owner for any given Plan of Work.
 - Agenda for Kick-Off meeting must include:
 - Review of administrative requirements
 - Confirmation of Plan of Work scope
 - Approval of Plan of Work schedule
 - Review of Plan of Work delivery process
 - Deliverables must include:
 - Meeting agenda
 - Meeting Summary
 - Plan of Work scoping document
 - Plan of Work schedule
- Review of existing conditions, at minimum, Contractor is required to:
 - Review Plan of Work
 - Identify Plan of Work plan and schedule
 - Define deliverables for Plan of Work, expected function and quality
- Attend meetings, as required by Project Manager
- Initiate timely invoices
- Compensation for Plan of Work services will generally be based on a total “time and materials” not-to-exceed amount for services at the time services are requested using the Schedule of Items unit prices as provided under this RFP. Quantities shall be estimated and billed at the Schedule of Items unit prices indicated in Exhibit 3 of the Contract.
- Projects \$150,000.00 and up, or at the discretion of OSU, will require payment and performance bonds.
- Projects will **NOT** include parking and travel expenses for individuals traveling to the jobsite.

2.0 SCHEDULE

Issue Date		January 23, 2025
Non-Mandatory Pre Proposal Conference		February 4, 2025 at 11:00 AM Pacific Time (PT) at the Research Forests Office, located at 8692 Northwest Peavy Arboretum Road, Corvallis, Oregon 97330
Question Deadline		February 11, 2025 at 4:00 PM Pacific Time (PT)
Final Addendum Issuance (if necessary)		February 18, 2025 at 4:00 PM Pacific Time (PT)
RFP DUE DATE/TIME		February 25, 2025 at 3:00 PM Pacific Time (PT) via electronic submission to Bids@oregonstate.edu

The following dates are tentative and subject to change without notice:

Notice of Intent to Award	March 14, 2025
Estimated Contract execution	March 28, 2025
Estimated Notice to Proceed	March 28, 2025

OSU will make every effort to adhere to the above schedule. It is however, subject to change.

3.0 QUESTIONS, SOLICITATION REVISION REQUESTS, CHANGE OR MODIFICATION, APPEALS

3.1 Questions.

3.1.1 All questions and contacts with OSU regarding any information in this RFP must be addressed in writing via email to constructioncontracts@oregonstate.edu no later than the **Question Deadline** as stated in Section 2.0. If a Proposer is unclear about *any* information contained in this document or its exhibits (Project, scope, etc.), they are urged to submit those questions for formal clarification.

3.2 Solicitation Process Revision Requests.

3.2.1 Proposers may submit a written request for change of particular solicitation process provisions to the **Director & Chief Procurement Officer** at the address or email listed in this document. Such requests for change shall be received no later than the **Question Deadline** listed above.

3.2.2 Such requests for change shall include the reasons for the request and any proposed changes to the solicitation process provisions.

3.3 Change or Modification.

3.3.1 Any change or modification provided by the Owner for this RFP or the documents included as exhibits to this RFP shall be made by a duly issued Addendum made available to all firms on the [OSU Business and Bid Opportunities](#) website. It is the responsibility of each Proposer to visit the website and download any addenda. No information received in any manner different than as described herein shall serve to change the RFP in any way, regardless of the source of the information.

3.3.2 OSU will not be responsible for any other explanation or interpretation of this RFP or the documents included as exhibits to this RFP.

3.4 Appeals.

3.4.1 Appeals related to the OSU solicitation process and award decisions and actions shall be pursuant to OSU Standards ([Procurement Thresholds and Methods, Procurement Solicitations and Contracts](#)). All written appeals must be delivered to the **Construction Contracts Manager**, at the address given in this RFP.

4.0 PUBLIC RECORD

4.1 OSU will retain an electronic copy of this RFP and one electronic copy of each Proposal received, together with electronic copies of all documents pertaining to the award of a contract. These documents will be made a part of a file or record, which shall be open to public inspection after OSU has announced its intent to award a contract. If a Proposal contains any information that is considered a trade secret under ORS 192.345(2), you must mark each trade secret with the following legend: **“This data constitutes a trade secret under ORS 192.345(2), and shall not be disclosed except in accordance with the Oregon Public Records Law, ORS Chapter 192.”**

4.2 The Oregon Public Records Law exempts from disclosure only bona fide trade secrets, and the exemption from disclosure applies only “unless the public interest requires disclosure in the particular instance.”

4.2.1 Therefore, non-disclosure of documents or any portion of a document submitted as part of a Proposal may depend upon official or judicial determination made pursuant to the Public Records Law.

4.3 In order to facilitate public inspection of the non-confidential portion of the Proposal, material designated as confidential shall accompany the Proposal, but shall be readily separable from it. Prices, makes, model or catalog numbers of items offered, scheduled delivery dates, and terms of payment shall be publicly available regardless of any designation to the contrary. Any Proposal marked as a trade secret in its entirety may be considered non-responsive and be rejected.

5.0 FORM OF AGREEMENT

A Sample Master Contract is included as an exhibit and contains contract terms and conditions applicable to the work. The sample contract may contain certain notes or alternative provisions. Those alternative provisions will be included at the sole discretion of OSU.

6.0 RESERVED OR BUREAU OF LABOR AND INDUSTRIES (BOLI) PREVAILING WAGES

In compliance with Oregon Prevailing Wage Law, the following is incorporated into this RFP:

The Contractor and all subcontractors shall comply with the provisions of ORS 279C.800 through 279C.870, relative to Prevailing Wage Rates (PWR) as outlined in Sections C.1 and C.2 of the General Conditions. The resulting Master Contract, PO’s, and Amendments are subject to the following Bureau of Labor and Industries (BOLI) wage rate requirements, which are incorporated herein by reference:

- January 5, 2025 PWR Apprenticeship Rates
- January 5, 2025 PWR for Public Works Contracts in Oregon
- October 5, 2024 Definitions of Covered Occupations for Public Works Contracts in Oregon

These BOLI wage rates are available here: https://www.oregon.gov/boli/WHD/PWR/Pages/pwr_state.aspx.

7.0 INSTRUCTIONS TO PROPOSERS

7.1 Summary of Work. The Work contemplated in this document shall be for OSU in connection with the Project described in Section 1.0 of this document.

7.2 Pre-Proposal Conference.

7.2.1 The Non-Mandatory Pre Proposal Conference shall take place February 4, 2025 at 11:00 AM Pacific Time (PT) at the Research Forests Office, located at 8692 Northwest Peavy Arboretum Road, Corvallis, Oregon 97330.

7.2.2 No statement made by any officer, agent, or employee of OSU in relation to the physical conditions pertaining to the Work site will be binding on OSU, unless included in writing in the documents included as exhibits to this RFP or an Addendum.

7.2.3 Date and Time of a Pre-Proposal Conference is located on the cover sheet of this RFP.

7.3 Proposal Submission.

7.3.1 Submit **one (1) electronic version via email** to be received by the Due Date/Time listed in this document to Bids@oregonstate.edu as stated in this RFP. **Electronic versions must be sized appropriately for transfer (under 10 mb).**

7.3.2 All Proposals must be received by OSU before the Due Date/Time. OSU's official clock shall prevail in any time conflict. Any Proposal received after the Due Date/Time will be rejected and will be retained and made part of OSU's archive records in accordance with OSU Standards.

7.3.3 All Proposers must be registered and licensed with the Oregon Construction Contractors Board and have on file with the Construction Contractors Board the required public works bond prior to submitting Proposals. Failure to be licensed and have the bond in place will be sufficient cause to reject Proposals as non-responsive.

7.4 Proposal Submission Requirements.

7.4.1 Your Proposal must be contained in a document not to exceed ten (10) single sided pages including pictures, charts, graphs, tables and text you deem appropriate to be part of OSU's review of your Proposal. Resumes of key individuals proposed to be involved in this Project are exempted from the page limit and must be appended to the end of your Proposal. No supplemental information to the page limit will be allowed. Appended resumes of the proposed key individuals, along with a Transmittal letter, table of contents, front and back covers, references, the completed Schedule of Items, valid copy of AOL Oregon Professional Logger certification, and blank section dividers will not be counted in the page limit.

7.4.2 Your Proposal must follow the format outlined below and include a Transmittal/Cover Letter signed by an officer of your firm(s) with the authority to commit the firm(s) and must also acknowledge receipt of all addenda. **An email must be included** for communication purposes.

7.4.3 Any/all exceptions to the Terms and Conditions included in the Sample Contract shall be clearly identified and appended to the Proposal in order to be considered by OSU during the negotiation period.

7.4.4 The electronic Proposal **should be sized appropriately for transfer (under 10 MB)** and formatted with page size of **8 ½ x 11 inches** with no fold-outs (except for any large format documents required by evaluation criteria). The basic text information of the Proposal should be presented in standard business font size, and reasonable margins.

7.4.5 OSU may reject any Proposal not in compliance with all applicable OSU solicitation procedures and requirements, and may cancel this solicitation or reject for good cause, all Proposals upon a finding by OSU that it is in the public interest to do so.

7.4.6 Note that throughout this procurement process, OSU will not accept Proposals that require OSU to pay the cost of production or delivery.

7.4.7 Telephone and facsimile transmitted **Proposals will not be accepted**. Proposals received *after* the Due Date/Time **will not be considered**.

7.4.8 Each Proposal shall be emailed to Bids@oregonstate.edu Proposals must be received by the date/time and in the format specified herein. The email line should contain the Solicitation Number/Name and Firm Name. **OSU shall not be responsible for missed RFP responses/questions/clarifications because the naming convention above was not used.** Only those Proposals received at this email address by the Proposal Due Date/Time shall be considered responsive. Proposals submitted directly to the **Contract Administrator** will NOT be considered responsive. It is highly recommended that the Proposer confirms receipt of the email with the **Contract Administrator or designee**. The **Contract Administrator** or designee may open the email to confirm receipt but will NOT verify the integrity of the attachment(s), answer questions related to the content of the Proposal, or address the overall responsiveness of the Proposal.

7.5 Acceptance or Rejection of Solicitation Responses by OSU.

7.5.1 The procedures for Contract awards shall be in compliance with the provisions of OSU standards and policies adopted by OSU.

7.5.2 OSU reserves the right to reject any or all Proposals and to waive minor informalities in compliance with the provisions of OSU standards and policies adopted by OSU.

7.6 Withdrawal of Solicitation Response.

7.6.1 At any time prior to the Due Date/Time, a Proposer may withdraw its Proposal in accordance with OSU Standards. This will not preclude the submission of another Proposal by such Proposer prior to the Due Date/Time.

7.6.2 After the Due Date/Time, Proposers are prohibited from withdrawing their Proposal, except as provided by OSU Standards.

7.7 Evaluation Process. The written response to this RFP is the only step in the selection of a firm for this Project. The Proposals received in response to this RFP will be evaluated by a selection committee.

The members of the selection committee will discuss the strengths and weaknesses of all Proposers. The members of the selection committee will then score the Proposers based on all information received and presented in the Proposals. Optional Reference Checks may be undertaken to aid in final scoring. Upon completion of final scoring, an Intent to Award will be issued identifying the Apparent Successful Proposer and negotiations may commence with the Apparent Successful Proposer in order to finalize a contract in accordance with Section 7.12 below.

7.8 Evaluation Criteria. The following items constitute the evaluation criteria for the selection committee to score Proposals. For ease in reviewing, provide tabs keyed to each of the following criteria:

7.8.1 Equipment List (15 Points)

Provide a list of equipment your firm either owns or can procure to meet the equipment requirements in the Schedule of Items. This must include make, model, year of manufacture, and net engine horsepower. Note the owner of the equipment and justify in three (3) sentences or less, for each equipment listed on the Schedule of Items, how the equipment meets the minimum technical specification.

7.8.2 Stream Improvement Experience (10 Points)

Provide a list and brief summary of the projects you have worked on in the last five (5) years relating to fish passage structure installation, barrier removal, and stream stabilization/rehabilitation.

7.8.3 Safety and Professionalism (15 Points)

The Research Forests have high levels of non-motorized recreational use. Describe how you will provide for public safety during operations and handle interactions with individuals that have ignored closures and entered the work site.

Provide the following safety record information: (If you are a division of a larger corporation doing business both within the Pacific Northwest and outside the Pacific Northwest, your proposal must reflect your Pacific Northwest experience and your corporate experience, separately.)

- Experience Modification Rate (EMR) for each of the last five years.
- Lost Time and Recordable Incident Rates for each of the last five years.
- OSHA fines for each of the last five years (including any fines initially imposed, but later rescinded). Include a brief summary and amount of each fine.
- Your corporate safety philosophy and approach to an Injury Free Environment (IFE) including a description of how this philosophy is implemented from senior management to all workers.

7.8.4 Base Bid (45 Points)

Submit completed Schedule of Items in Attachment 3. The unit prices as submitted on the Schedule of Items shall remain unchanged for the term of the Contract, unless otherwise agreed to by the Contractor and OSU in the form of a written amendment to the Contract. Any escalation to the unit prices on the Schedule of Items shall be reviewed and may be approved by OSU upon execution of a written amendment to the Contract, if the Contract has been extended beyond the initial three year term. Unit Prices shall be inclusive of all labor and material costs required to perform the services described in this RFP. The Proposer with the lowest total base Bid will receive full points; higher cost Bids will receive proportionally lower points according the following formula:

(Low Total Sum of Base Bid/ Sum of Total Base Bid) x 45 Points

7.8.5 Workforce Diversity Plan (15 Points)

(a) Provide a description and identification of Minority Business Enterprise (MBE), Women Business Enterprise (WBE), Emerging Small Business (ESB), or Disabled Service Veterans (DSV) certifications for your team and a description of your nondiscrimination practices. Provide historical information on MBE, WBE, ESB, or DSV Joint Ventures, subcontracting or mentoring plan, and utilization history for projects completed by your firm within the past three (3) years.

(b) Provide a narrative description of your current workforce diversity program/plan, and the plan for obtaining subcontracting, consulting, and supplier diversity for this Project. Include a description of the outreach program or plan, including a schedule of events and specific steps that will be taken to maximize broad based and inclusive participation and the plan to provide mentoring, technical or other business development services to subcontractors/subconsultants needing or requesting such services.

The successful Proposer must perform the Work according to the means and methods described in the workforce plan described in its Proposal, unless changes are requested and approved in writing in advance by OSU or are required by applicable laws, ordinances, codes, regulations, rules or standards.

7.9 Point Summary Table.

Criteria	Point Value
Equipment List	15 Points
Stream Improvement Experience	10 Points
Safety and Professionalism	15 Points
Base Bid	45 Points
Workforce Diversity Plan	15 Points

7.11 Equity Contracting. OSU will require the successful Proposer to comply with OSU Standards, policies, rules and procedures requiring good faith efforts in subcontracting with minority, women, emerging small business or service-disabled veteran owned business enterprises.

7.12 Negotiations.

7.12.1 OSU may commence General and/or Best and Final Offer (BAFO) Negotiations in accordance with OSU Standards ([*Procurement Thresholds and Methods, Procurement Solicitations and Contracts*](#)) following final scoring under either a one or two-step process.

7.12.2 If OSU and the Apparent Successful Proposer are unable to reach agreement on contract terms and conditions, OSU may cease negotiations with the Apparent Successful Proposer and enter negotiations with the next highest scoring Proposer, etc.

8.0 MISCELLANEOUS

8.1 Financial Responsibility.

8.1.1 OSU reserves the right to investigate, at any time prior to execution of the contract, the Proposers financial responsibility to perform the anticipated services. Submission of a Proposal will constitute approval for OSU to obtain any credit report information OSU deems necessary to conduct the evaluation. OSU will notify Proposers, in writing, of any other documentation required, which may include, but need not be limited to: recent profit-and-loss history; current balance statements; assets-to-liabilities ratio, including number and amount of secured versus unsecured creditor claims; availability of short and long-term financing; bonding capacity and credit information. Failure to promptly provide this information may result in rejection of the Proposal.

8.1.2 OSU may postpone the selection of finalists or execution of a contract in order to complete its investigation and evaluation. Failure of a firm to demonstrate financial responsibility may render it non-responsible and constitute grounds for Proposal rejection.

8.2 Project Termination.

8.2.1 OSU reserves the right to terminate the Project or contract during any phase in the Project.

8.3 Insurance Provisions. During the term of the resulting contract, the awardee will be required to maintain in full force, at its own expense, from insurance companies authorized to transact the business of insurance in the state of Oregon, each insurance coverage/policy as set forth in the contract.

8.4 Nondiscrimination. By submission of a Proposal, the Proposer certifies under penalty of perjury that the Proposer will not discriminate against minority, women, emerging small business or service-disabled veteran owned business enterprises in obtaining any required subcontracts.

8.5 AA/EEO Employer. OSU is an AA/EEO employer.

8.6 Compliance with Applicable Law. Proposer agrees to comply with all federal, state, county, and local laws, ordinances, and regulations as well as all applicable OSU Standards and Policies while on campus.

8.6.1 Smoke and Tobacco Free Campus. Owner's grounds and premises are smoke and tobacco free. Contractor and Contractor's employees, agents, Subcontractors, if any, agree not to smoke or use tobacco products while on Owner property.

8.6.2 Sexual Misconduct Policy. OSU has policies that prohibit sexual misconduct against members of the university community and in keeping with those policies Contractor and Contractor's employees, agents, and Subcontractors are prohibited from engaging in sexual misconduct against members of the university community.

8.6.3 Firearms Policy. The Owner has adopted a policy that prohibits Contractor and Contractor's employees, agents and Subcontractors from possessing firearms on Owner's property.

8.7 Background Checks. Some areas could be designated as critical, occupied or security-sensitive facilities. Thus, the selected Contractor shall conduct criminal background checks, including sex offender registration checks, (for both: Oregon at a minimum, and national for Contractor employees that formerly lived outside of the state of Oregon) on each Contractor employee and agent with satisfactory results before referral or placement at any Owner work location. Contractor must perform the criminal background checks within the twelve (12) months immediately preceding referral or placement at any Owner work location.

Disqualifying crimes include 1) felony convictions of any kind within the last eight (8) years, 2) all crimes involving weapons of any kind ever committed, 3) all person to person crimes involving physical injury to another person ever committed, 4) sexual offenses of any kind ever committed, including stalking, and 5) child abuse, molestation, child pornography or other crimes involving child endangerment, including neglect and abandonment of any kind ever committed.

Contractor shall require Contractor's employees and agents to self-disclose to Contractor any new convictions that occur within three business days of the conviction. Contractor shall reassess the individual's assignment under the Contract.

The Owner, at its discretion, may require Contractor to reassign a Contractor employee or agent to no longer perform work under the Contract or for the Owner if, at any time, Owner believes that the Contractor employee or agent may create a danger to health or safety of the university community.

Contractor is solely responsible for complying with all applicable federal, state or local laws, rule and regulations, including but not limited to the Fair Credit Reporting Act and equal opportunity laws and regulations, when conducting background checks. The costs and Fair Credit Reporting Act obligations for criminal background checks are the responsibility of Contractor.

Contractor shall maintain a security log including a list of Contractor employees working in, accessing, or who will enter Owner critical, occupied or security-sensitive facilities; verification of each Contractor employee's satisfactory and unsatisfactory results of criminal background checks; each Contractor employee's site assignment; and each revocation of a Contractor employee's site assignment. Contractor shall update and maintain the security log during the duration of the contract and twenty-four (24) months after. Contractor shall provide Owner with access to the security log for audit and copying purposes within twenty-four (24) hours of Owner's request.

Contractor shall require Contractor's subcontractors and agents providing services under the Contract to comply with this provision. The Owner may audit Contractor's background check processes at any time to ensure compliance with this section. Failure of Contractor to comply with this section is a material breach of the resulting Contract and may result in the Owner seeking monetary damages or pursue other remedies, Contractor termination by the Owner without further liability or obligation, or both. Contractor shall indemnify, defend and hold harmless the Owner and its directors, agents, trustees and employees from all claims, suits, and actions arising out of or related to any and all claims relating to the conducting of such checks and any adverse action that may be taken as a result of such checks.

8.8 Execution of Agreement.

8.8.1 The Proposer shall be required to execute the Contract as provided, within any time period provided in an award notification. The Contract Documents shall be delivered to OSU in the manner stated in an award notification.

8.8.2 Work/Services Commencement. Work/Services shall not commence until execution of a Contract and subsequent issuance of a notice to proceed letter with the selected Proposer.

8.9 Reservation of OSU's Rights

8.9.1 Cancel, withdraw, postpone, or extend this RFP, in whole or in part, at any time prior to the execution of the Agreement, without incurring any obligations or liabilities.

8.9.2 Modify the procurement schedule.

8.9.3 Waive deficiencies, informalities, and irregularities in a Response and accept and review a non-conforming Response.

8.9.4 Suspend and terminate the procurement process or terminate evaluations of Responses received.

8.9.5 Permit corrections to data submitted with any Response.

8.9.6 Hold meetings and interviews, and conduct discussions and correspondence, with one or more of the Proposers to seek an improved understanding of any information contained in a Response.

8.9.7 Seek or obtain, from any source, data that has the potential to improve the understanding and evaluation of the Responses.

8.9.8 Seek clarification from any Proposer to fully understand information provided in the Response and to help evaluate and rank the Proposers.

8.9.9 Reject a Response containing exceptions, additions, qualifications, or conditions not called for in the RFP or otherwise not acceptable to OSU.

8.9.10 Conduct an independent investigation of any information, including prior experience, included in a Response by contacting project references, accessing public information, contacting independent parties, or any other means.

8.9.11 Request additional information from a Proposer during the evaluation of its Response.

8.9.12 Negotiate with one or more Proposers regarding any particular or all aspects of the Agreement as determined by OSU in its sole discretion. However, OSU does not have to negotiate with any Proposer. The successful Proposer may be required to sign the Agreement with OSU without negotiation of any terms or conditions.

9.0 EXHIBITS

Exhibit 1	Sample Master Contract
	Includes OSU General Conditions, Supplemental General Conditions, Sample PO, and Sample Performance and Payment Bond
Exhibit 2	General Conditions
Exhibit 3	MWESB Instruction and Form
Exhibit 4	Technical Specifications
Exhibit 5	Unit Pricing
Exhibit 6	Typical Drawings
Exhibit 7	Maps
Exhibit 8	Schedule of Items

END OF RFP

**MASTER CONTRACT FOR FOREST ROAD INFRASTRUCTURE
OREGON STATE UNIVERSITY
CONTRACT NUMBER XXXXXX**

This Master Contract for Forest Road Infrastructure (Contract), effective upon the last signature of a party to it, is between:

Contractor:	Name Address Address Address
and Owner:	Oregon State University 644 Southwest 13th Street Corvallis, Oregon 97333

(each, a Party and collectively, the Parties).

RECITALS

WHEREAS, Owner issued certain Solicitation Documents inviting firms to provide forest road infrastructure related services to Owner; and

WHEREAS, Owner having received and evaluated the responses to the Solicitation Documents, now desires to award a Contract to Contractor; and

WHEREAS, Contractor desires to provide Forest road infrastructure related services to Owner; and

NOW, THEREFORE, for good and valuable consideration, the receipt and sufficiency of which is hereby acknowledged, the Parties, intending to be legally bound agree as follows:

AGREEMENT

1. INCORPORATION OF TERMS AND DOCUMENTS

Contractor agrees to provide Forest road infrastructure related services (Work) to Owner in accordance with the Solicitation Document; and with the General Conditions for Master Contracts for Construction Related Services, Oregon State University, dated July 1, 2019 (the General Conditions), included as **Exhibit A**, and attached hereto and incorporated herein by these references. Capitalized terms not otherwise defined in this Contract shall have the meanings ascribed to them in the General Conditions.

2. WORK

Owner may request Work of Contractor pursuant to Contract Documents for specific construction activity (each, a Plan of Work) throughout the Term (as defined below) of the Contract. Upon receipt of such a request (each such request, a Plan of Work Request), Contractor may respond to the Request for specific Work, as defined in the Request. For every response to a Plan of Work Request, Contractor shall coordinate with the Owner's project manager (Project Manager), attend site visit (if required by Project Manager), provide recommendations and revisions to scope of work on Contractor's practical experience in forest road maintenance infrastructure, construction and horizontal earthwork projects, if applicable, provide an estimate price (in accordance with the Plan of Work Request and this Contract) estimate for the Plan of Work within one business day (for standard work orders), unless otherwise stated by the Project Manager. All Plan of Work estimates provided under this Contract must contain a detailed completed cost breakdown, utilizing pricing in the Schedule of Items (**Exhibit E**)

Upon Owner's election to award a Plan of Work to Contractor, the scope and cost of the Work with regard to each such specific Plan of Work will be specified in an Owner issued written Contract amendment (each, an Amendment). The form of such Amendments may be a purchase order substantially similar to the purchase order attached as **Exhibit B**. Each purchase order when signed by the Owner, creates a binding obligation between the Parties and a Notice to Proceed may be issued. Each such Amendment shall be incorporated into the Contract Documents upon full execution thereof. From time to time, Owner and Contractor may elect to amend an Amendment by way of a modification to the Amendment, related to the scope of work of the Amendment (each such modification to an amendment, a Modification).

The type of work anticipated under this Contract may include, but are not limited to, the following:

- A. Pipe arch culvert replacement
- B. Re-opening of overgrown road for timber harvest access
- C. Culvert and road approach to county road
- D. Post-harvest road rocking, grading and compactive rolling
- E. On-going culvert replacement and upgrades
- F. Occasional construction of dirt and rocked spur roads for harvest access

The Work of Plan of Works will occur within, but not limited to research forest tracts that the Owner manages including, but not limited to:

- G. Benton County: McDonald Dunn, Cameron, Spaulding, Marchel;
- H. Columbia County: Blodgett;
- I. Washington County: Matteson;
- J. Clackamas County, Ram's Dell;
- K. Jackson County: Collins;
- L. Union County: Oberteuffer

Typical drawings applying to anticipated work are located in **Exhibit I**.

Maps of each research forest tracts described above are located in **Exhibit D**.

Upon award of an Amendment, Contractor shall initiate kick-off meetings with Owner, review of existing conditions, attend meetings with the Owner, as required by the Project Manager, and initiate timely invoices. Contractor's Work shall comply with the Contract Documents, Technical Specifications as stated in **Exhibit H** and Applicable Laws and shall be performed in accordance with the professional skill, care, and standards of other professionals performing similar work under similar conditions.

The kick-off meetings shall include, but are not limited to a review of the administrative requirements, confirmation of Plan of Work scope, approval of Plan of Work schedule, and review of Plan of Work delivery process. The Contractor shall deliver to the Project Manager a meeting agenda, meeting summary, Plan of Work scoping document and Plan of Work schedule within two (2) Days, unless otherwise agreed to by Project Manager. The review of existing conditions shall include, at a minimum, a review of the Plan of Work, identification of the Plan of Work plan and schedule and deliverables for Plan of Work, expected function and quality.

3. OWNER DOES NOT GUARANTEE THAT WORK WILL BE REQUESTED

Contractor acknowledges and agrees that, until execution of an Amendment requiring Road infrastructure activities, Owner does not warrant or guarantee that any Work will be requested or authorized under this Contract. No Work shall be undertaken by Contractor pursuant to this Contract without a fully executed Amendment, detailing the specific Work associated with a Plan of Work.

4. COMPENSATION

Owner agrees to compensate Contractor for Work in accordance with the Amendment and Contract Documents.

Plan of Works shall be compensated on a unit prices, unless otherwise stated by the Project Manager in the Plan of Work Request. Unit prices are indicated in the Schedule of Items in **Exhibit E**. If Payment and Performance Bonds are required by the Plan of Work Request, those bond costs are required to be included in the detailed cost breakdown. Bond costs are to be included at Contractor cost, with no mark up.

Contractor's Schedule of Items are identified in **Exhibit E** and are inclusive of all labor costs, material costs, equipment costs, overhead and profit to perform the Services described in this Contract.

Work performed by sub-contractors, if any, shall be reimbursed by the Owner at the Contractor's cost, without mark up.

The Schedule of Items, as identified in **Exhibit E** shall remain unchanged for the Term of this Contract, unless otherwise agreed to by the Parties in the form of a written amendment to this Contract. Any escalation of the hourly rates identified in **Exhibit E** shall be reviewed and may be approved by the Owner upon written request by the Contract if the Contract has been extended beyond the expiration date indicated in Section 5 of this Contract.

Pursuant to ORS 305.385 and Oregon State University Standards and as a condition precedent to Owner's obligation to make any payment due Contractor under this Contract, Contractor shall provide Owner with its Social Security or federal employer identification number, as applicable.

5. TERM AND TERMINATION

The term of this Contract (the Term) commences on the full execution hereof and expires on March 31, 2028. Owner has the option, but not the obligation to extend the Term of this Contract for two (2) additional twelve (12) month terms based on the current terms and conditions. In addition to Owner's rights provided in the General Conditions, Owner may terminate this Contract immediately upon Contractor's default under this Contract or any Amendment or Modification issued hereunder.

Each Amendment may be terminated in accordance with its terms.

6. MINIMUM WAGE RATES.

The Contractor and all subcontractors shall comply with the provisions of Oregon Revised Statutes (ORS) 279C.800 through 279C.870, relative to PWR and the required public works bond, as outlined in Sections C.1, C.2 and G.2.3 of the General Conditions. Oregon State Bureau of Labor and Industries (BOLI) PWR requirements, which are incorporated herein by reference, apply to Amendments authorized under this Contract:

PWR for Public Works Contracts in Oregon:

- January 5, 2025 PWR Apprenticeship Rates
- January 5, 2025 PWR for Public Works Contracts in Oregon
- October 5, 2024 Definitions of Covered Occupations for Public Works Contracts in Oregon

These BOLI PWR are available on line [here](#).

7. PERFORMANCE AND PAYMENT BONDS

Contractor shall provide to Owner a performance bond and a separate payment bond in accordance with the General Conditions for each separate Plan of Work, pursuant to an Amendment in the amount of the Contract Price for that Plan of Work. Receipt of such bonds by Owner shall be a condition precedent to the effectiveness of any Amendment or Modification and to any payment due Contractor under such Amendment or Modifications.

8. PAYMENTS

Contractor shall submit applications for payment and Owner shall make payments for Work completed by Contractor in accordance with the General Conditions.

9. INSURANCE

Contractor shall maintain in full force, at its own expense, and for the Term, any and all insurance required by the Contract Documents.

10. OWNERSHIP OF WORK PRODUCT

Any Plans, Specifications, reports, or other materials required to be delivered by Contractor pursuant to an Amendment, whether completed, partially completed or in draft form (the Work Product) shall be the exclusive property of Owner. Owner and Contractor intend that such Work Product be deemed work made for hire under 17 United States Code (U.S.C.) §101, as amended, of which Owner will be deemed the author. Contractor hereby irrevocably assigns to Owner all of its right, title, and interest in and to any and all of the Work Product, whether arising from copyright, patent, trademark, trade secret, or any other state or federal intellectual property law or doctrine. Contractor shall execute such further documents and instruments as Owner may reasonably request or require in order to fully vest such rights in Owner.

Contractor forever waives any and all rights relating to the Work Product, including without limitation, any and all rights arising under 17 U.S.C. Sec. 106A or any other rights of identification of authorship or rights of approval, restriction or limitation on use or subsequent modifications.

If applicable, Contractor will comply with Applicable Laws governing patents, copyrights, licenses and trademarks and will pay all required fees to the holders thereof. Contractor shall indemnify, defend (with counsel acceptable to Owner) and hold harmless Oregon State University, and their respective members, agents and employees of and from any and all claims, demands, losses, causes of action, damages, lawsuits, judgments, including attorneys' fees and costs, arising out of or relating to patent, license, copyright, and trademark infringements arising out of the actions of Contractor, its subcontractors, agents, and employees.

11. AMENDMENTS

Any change to the terms and conditions of this Contract shall be made only upon a fully executed written Amendment or Modification.

12. NOTICES

Except as otherwise expressly provided for in the Contract Documents, any notices to be given to OSU shall be given in writing by personal delivery or mailing the same, postage prepaid to Oregon State University at the address listed below. Any notice so addressed and mailed shall be deemed to be given five (5) calendar days after the date of mailing. Any notice by personal delivery shall be deemed to be given when actually delivered.

Mark Swanson
Director of the Research Forests
Oregon State University
College of Forestry
Peavy Arboretum
8692 Northwest Peavy Arboretum Road
Corvallis, Oregon 97330

With a CC to:

Construction Contracts Administration
Oregon State University
644 Southwest 13th Street
Corvallis, Oregon 97333

13. LICENSING; LEGAL CAPACITY TO CONDUCT BUSINESS

Contractor shall be licensed to do business in the State of Oregon and shall continuously maintain all licenses required by Applicable Laws for the operation of its business or performance of the Work under this Contract throughout the Term. Contractor shall demonstrate its legal capacity to do business and perform the Work in the State of Oregon before entering into any Amendment. Contractor shall also be licensed by the Oregon Professional Loggers Association throughout the Term of this Contract.

14. SECURITY/ BACKGROUND CHECK

The Oregon State University (OSU) facilities in which work performed under this Contract is performed may be designated as critical, occupied or security-sensitive areas. Thus, Contractor shall conduct criminal background checks, including sex offender registration checks, (for both: Oregon at a minimum, and national for Contractor employees that formerly lived outside of the state of Oregon) on each Contractor employee and agent with satisfactory results before referral or placement at any OSU work location. The Contractor shall also conduct drug and alcohol testing of each Contractor employee and agent with satisfactory results before referral or placement at any OSU work location. Contractor must perform the criminal background checks and drug and alcohol testing within the twelve (12) months immediately preceding referral or placement at any Owner work location.

Disqualifying crimes include 1) felony convictions of any kind within the last eight (8) years, 2) all crimes involving weapons of any kind ever committed, 3) all person to person crimes involving physical injury to another person ever committed, 4) sexual offenses of any kind ever committed, including stalking, and 5) child abuse, molestation, child pornography or other crimes involving child endangerment, including neglect and abandonment of any kind ever committed.

Contractor shall require Contractor's employees and agents to self-disclose to Contractor any new convictions that occur within three business days of the conviction Contractor shall reassess the individual's assignment under this Contract.

The Owner, at its discretion, may require Contract to reassign a Contractor employee or agent to no longer perform work under this Contract or for the Owner if, at any time, Owner believes that the Contractor employee or agent may create a danger to health or safety of the university community.

Contractor is solely responsible for complying with all applicable federal, state or local laws, rule and regulations, including but not limited to the Fair Credit Reporting Act and equal opportunity laws and regulations, when conducting background checks. The costs and Fair Credit Reporting Act obligations for criminal background checks and drug and alcohol testing are the responsibility of Contractor.

Contractor shall maintain a security log including a list of Contractor employees working in, accessing, or who will enter OSU critical, occupied or security-sensitive facilities; verification of each Contractor employee's satisfactory and unsatisfactory results of criminal background checks; verification of each Contractor employee's satisfactory and unsatisfactory results of drug and alcohol testing; each Contractor employee's OSU assignment; and each revocation of a Contractor employee's OSU assignment. Contractor shall update and maintain the security log during the duration of the contract and twenty-four (24) months after. Contractor shall provide Owner with access to the security log for audit and copying purposes within twenty-four (24) hours of Owner's request.

Contractor shall require Contractor's subcontractors and agents providing services under this Contract to comply with this provision. The Owner may audit Contractor's background checks and drug and alcohol testing processes at any time to ensure compliance with this section. Failure of Contractor to comply with this section is a material breach of the Contract and may result in the Owner seeking monetary damages or pursue other remedies, Contractor termination by the Owner without further liability or obligation, or both. Contractor shall indemnify, defend and hold harmless the Owner and its directors, agents, trustees and employees from all claims, suits, and actions arising out of or related to any and all claims relating to the conducting of such checks and testing and any adverse action that may be taken as a result of such checks and testing.

15. SMOKE AND TOBACCO FREE CAMPUS

Contractor acknowledges and agrees Owner's grounds and premises are smoke and tobacco free. Contractor and Contractor's employees, agents and subcontractors, if any, agree not to smoke or use tobacco products while on Owner property.

16. SEXUAL HARASSMENT POLICY

The Owner has policies that prohibit sexual harassment of members of the university community and in keeping with those policies Contractor and Contractor's employees, agents, and subcontractors are prohibited from engaging in sexual harassment of members of the university community.

17. FIREARMS POLICY

The Owner has adopted a policy that prohibits Contractor and Contractor's employees, agents, and subcontractors from possessing firearms on Owner's property.

18. EXECUTION AND COUNTERPARTS

This Contract and any Amendment or Modification hereto may be executed in several counterparts, each of which shall be an original, all of which shall constitute but one and the same instrument.

19. SEVERABILITY

If any term or provision of the Contract Documents is declared by a court of competent jurisdiction to be illegal or in conflict with any law, the validity of the remaining terms and provisions shall not be affected, and the rights and obligations of the Parties shall be construed and enforced as if the Contract Documents did not contain the particular term or provision held to be invalid.

20. MERGER CLAUSE

THIS CONTRACT, TOGETHER WITH THE OTHER CONTRACT DOCUMENTS, CONSTITUTES THE ENTIRE AGREEMENT BETWEEN THE PARTIES. THERE ARE NO UNDERSTANDINGS, AGREEMENTS, OR REPRESENTATIONS, ORAL OR WRITTEN, NOT SPECIFIED HEREIN REGARDING THIS CONTRACT. NO AMENDMENT, CONSENT, OR WAIVER OF TERMS OF THIS CONTRACT WILL BIND EITHER PARTY UNLESS IN WRITING AND SIGNED BY THE PARTIES. ANY SUCH AMENDMENT, CONSENT, OR WAIVER WILL BE EFFECTIVE ONLY IN THE SPECIFIC INSTANCE AND FOR THE SPECIFIC PURPOSE GIVEN. CONTRACTOR, BY THE SIGNATURE BELOW OF ITS AUTHORIZED REPRESENTATIVE, ACKNOWLEDGES HAVING READ AND UNDERSTOOD THIS CONTRACT AND AGREES TO BE BOUND BY ITS TERMS AND CONDITIONS.

IN WITNESS HEREOF, the Parties have duly executed this Contract as of the dates indicated below.

XXXX, Contractor

Oregon State University, Owner

Signature

Date

Bruce Daley
Associate Vice President for
University Facilities, Infrastructure
and Operations

Date

Print Name

Title

SAMPLE

SAMPLE

OREGON STATE UNIVERSITY GENERAL CONDITIONS MASTER CONTRACT FOR CONSTRUCTION RELATED SERVICES

July 1, 2019

INSTRUCTIONS: The attached **Oregon State University, Master Contract for Construction Related Services General Conditions ("General Conditions")** apply to all designated master contracts. Changes to the General Conditions (including any additions, deletions or substitutions) should only be made by attaching Supplemental General Conditions. The text of these General Conditions should not otherwise be altered.

TABLE OF SECTIONS

SECTION A **GENERAL PROVISIONS**

- A.1 DEFINITION OF TERMS
- A.2 SCOPE OF WORK
- A.3 INTERPRETATION OF CONTRACT DOCUMENTS
- A.4 EXAMINATION OF PLANS, SPECIFICATIONS, AND SITE
- A.5 INDEPENDENT CONTRACTOR STATUS
- A.6 RETIREMENT SYSTEM STATUS AND TAXES
- A.7 GOVERNMENT EMPLOYMENT STATUS

SECTION B **ADMINISTRATION OF THE CONTRACT**

- B.1 OWNER'S ADMINISTRATION OF THE CONTRACT
- B.2 CONTRACTOR'S MEANS AND METHODS
- B.3 MATERIALS AND WORKMANSHIP
- B.4 PERMITS
- B.5 COMPLIANCE WITH GOVERNMENT REGULATIONS
- B.6 SUPERINTENDENCE
- B.7 INSPECTION
- B.8 SEVERABILITY
- B.9 ACCESS TO RECORDS
- B.10 WAIVER
- B.11 SUBCONTRACTS AND ASSIGNMENT
- B.12 SUCCESSORS IN INTEREST
- B.13 OWNER'S RIGHT TO DO WORK
- B.14 OTHER CONTRACTS
- B.15 GOVERNING LAW
- B.16 LITIGATION
- B.17 ALLOWANCES
- B.18 SUBMITTALS, SHOP DRAWINGS, PRODUCT DATA, AND SAMPLES
- B.19 SUBSTITUTIONS
- B.20 USE OF PLANS AND SPECIFICATIONS
- B.21 FUNDS AVAILABLE AND AUTHORIZED
- B.22 NO THIRD PARTY BENEFICIARIES

SECTION C **WAGES AND LABOR**

- C.1 MINIMUM WAGES RATES ON PUBLIC WORKS
- C.2 PAYROLL CERTIFICATION AND FEE REQUIREMENTS
- C.3 PROMPT PAYMENT AND CONTRACT CONDITIONS
- C.4 PAYMENT FOR MEDICAL CARE
- C.5 HOURS OF LABOR

SECTION D **CHANGES IN THE WORK**

- D.1 CHANGES IN THE WORK
- D.2 DELAYS
- D.3 CLAIMS REVIEW PROCESS

SECTION E
PAYMENTS

- E.1 SCHEDULE OF VALUES
- E.2 APPLICATIONS FOR PAYMENT
- E.3 PAYROLL CERTIFICATION REQUIREMENT
- E.4 DUAL PAYMENT SOURCES
- E.5 RETAINAGE
- E.6 FINAL PAYMENT

SECTION F
JOB SITE CONDITIONS

- F.1 USE OF PREMISES
- F.2 PROTECTION OF WORKERS, PROPERTY, AND THE PUBLIC
- F.3 CUTTING AND PATCHING
- F.4 CLEANING UP
- F.5 ENVIRONMENTAL CONTAMINATION
- F.6 ENVIRONMENTAL CLEAN-UP
- F.7 FORCE MAJEURE

SECTION G
INDEMNITY, BONDING AND INSURANCE

- G.1 RESPONSIBILITY FOR DAMAGES/INDEMNITY
- G.2 PERFORMANCE AND PAYMENT SECURITY, PUBLIC WORKS BOND
- G.3 INSURANCE

SECTION H
SCHEDULE OF WORK

- H.1 CONTRACT PERIOD
- H.2 SCHEDULE
- H.3 PARTIAL OCCUPANCY OR USE

SECTION I
CORRECTION OF WORK

- I.1 CORRECTIONS OF WORK BEFORE FINAL PAYMENT
- I.2 WARRANTY WORK

SECTION J
SUSPENSION AND/OR TERMINATION OF THE WORK

- J.1 OWNER'S RIGHT TO SUSPEND THE WORK
- J.2 CONTRACTOR'S RESPONSIBILITIES
- J.3 COMPENSATION FOR SUSPENSION
- J.4 OWNER'S RIGHT TO TERMINATE CONTRACT
- J.5 TERMINATION FOR CONVENIENCE
- J.6 ACTION UPON TERMINATION

SECTION K
CONTRACT CLOSE-OUT

- K.1 RECORD DOCUMENTS
- K.2 OPERATION AND MAINTENANCE MANUALS
- K.3 COMPLETION NOTICES
- K.4 TRAINING
- K.5 EXTRA MATERIALS
- K.6 ENVIRONMENTAL CLEAN-UP
- K.7 CERTIFICATE OF OCCUPANCY
- K.8 OTHER CONTRACTOR RESPONSIBILITIES
- K.9 SURVIVAL

OREGON STATE UNIVERSITY
GENERAL CONDITIONS FOR MASTER CONTRACT FOR CONSTRUCTION RELATED SERVICES
(“General Conditions”)

SECTION A
GENERAL PROVISIONS

A.1 DEFINITION OF TERMS

In the Contract Documents, the following terms shall be as defined below:

AMENDMENT, means a writing which, when fully executed by the Parties to this Contract, constitutes a change to a Contract Document. Amendments to Supplements (hereinafter a “Supplement Amendment”) shall be issued in accordance with the changes provisions of Section D and, if applicable, establish a Contract Price or Contract Time adjustment.

APPLICABLE LAWS, means federal, state and local laws, codes, rules, regulations and ordinances applicable to the Work and to the Contract.

ARCHITECT/ENGINEER, means the Person appointed by the Owner to make drawings and specifications and, to provide contract administration of the Work contemplated by the Contract to the extent provided herein or by supplemental instruction of Owner (under which Owner may delegate responsibilities to the Architect/Engineer), in accordance with ORS Chapter 671 (Architects) or ORS Chapter 672 (Engineers) and administrative rules adopted thereunder.

CHANGE ORDER, means a written order issued by the Owner to be later included as an Amendment. A Change Order shall not be effective until codified as an Amendment.

CLAIM, means a demand by Contractor pursuant to Section D.3 for review of the denial of Contractor’s initial request for an adjustment of Contract terms, payment of money, extension of Contract Time or other relief, submitted in accordance with the requirements and within the time limits established for review of Claims in these General Conditions.

CONSTRUCTION CHANGE DIRECTIVE, means a written order by the Owner to the Contractor requiring a change in the Work within the general scope of the Contract Documents, issued under the changes provisions of Section D.

CONSTRUCTION SCHEDULE, means the schedule prepared by the Contractor in CPM format and approved by the Owner, and all adjustments thereto approved by the Owner, that describes sequence and timing of the Work.

CONTRACT, means the written agreement between the Owner and the Contractor comprised of the Contract Documents which describe the Work to be done and the obligations between the parties.

CONTRACT DOCUMENTS, means the Solicitation Document General Conditions, Supplemental General Conditions if any, Purchase Orders, the accepted Offer, Plans, Specifications, Change Orders Construction Change Directives, Solicitation Document and addenda thereto, Instructions to Offerors, and Supplemental Instructions to Offerors, and any other Amendment, the Construction Schedule prepared and approved in accordance with the Construction Documents, and all other required Submittals.

CONTRACT PERIOD, as set forth in the Contract Documents, means the total period of time beginning with the full execution of a Supplement and, if applicable, the issuance of a Notice to Proceed and concluding upon Final Completion.

CONTRACT PRICE, means the total of the awarded Offer amount, as increased or decreased by the price of approved alternates, as indicated in the Contract Documents.

CONTRACT TIME, means any incremental period of time allowed under the Contract to complete any portion of the Work as reflected in the project schedule.

CONTRACTOR, means the Person awarded the Contract for the Work contemplated.

CPM, means a critical path method format to be used for the Construction Schedule.

DAYS, are calendar days, including weekdays, weekends and holidays, unless otherwise specified.

DIRECT COSTS, means, unless otherwise provided in the Contract Documents, the cost of materials, including sales tax, cost of delivery; cost of labor, including social security, Medicare and unemployment insurance, and fringe benefits required by agreement or custom; worker’s compensation insurance; project specific insurance (including, without limitation, Builder’s Risk Insurance and Builder’s Risk Installation Floater); bond premiums, rental cost of equipment, and machinery required for execution of the Work; and the additional costs of field personnel directly attributable to the Work.

FINAL COMPLETION, means the final completion of all requirements under the Contract, including Contract Closeout as described in Section K but excluding Warranty Work as described in Section I.2, and the final payment and release of all retainage, if any, released.

FINAL PAYMENT, means the last payment to the Contractor, including retainage, in connection with the Work.

FORCE MAJEURE, means an act, event or occurrence caused by fire, riot, war, acts of God, nature, sovereign, or public enemy, strikes, freight embargoes or any other act, event or occurrence that is beyond the control of the party to this Contract who is asserting Force Majeure.

MWESB REPORT, means an accurate report by the Contractor to the Owner identifying all Minority, Women and Emerging Small Business (MWESB) enterprises, as those terms are defined in ORS 200.005, receiving contracts throughout the course of the Work. An initial MWESB report is required (see Section E.2.9) and MWESB Reports are required annually (see Section E.2.9) and as a condition of final payment (see Section K.1). The initial report shall include the total number of contracts and subcontracts awarded to MWESB enterprises and the dollar value of their respective contracts and subcontracts. The annual reports shall include the total number of contracts and subcontracts awarded to MWESB enterprises, the dollar value of each, and the expenditure toward each contract and subcontract during the previous twelve (12) months. The final report shall include the total number of contracts and subcontracts awarded to MWESB enterprises and the dollar value of their respective contracts and subcontracts including all Supplements and Amendments incorporated during the course of the project. The reports shall only include enterprises certified with the State of Oregon as MWESB enterprises and shall include individual identification of each enterprise as a Minority business enterprise, a Women business enterprise, and/or an Emerging Small Business Enterprise, as applicable.

NOTICE TO PROCEED, means the official written notice from the Owner stating that the Contractor is to proceed with the Work defined in the Contract Documents. Notwithstanding the Notice to Proceed, Contractor shall not be authorized to proceed with the Work until all initial Contract requirements, including the Contract, performance bond and payment bond, and certificates of insurance, have been fully executed and submitted to Owner in a suitable form.

OFFER, means a bid in connection with Instructions to Bidders or a proposal in connection with a Request for Proposals.

OFFEROR, means an entity who submits a response to a solicitation document.

OVERHEAD, means those items which may be included in the Contractor's markup (general and administrative expense and profit) and that shall not be charged as Direct Cost of the Work, including without limitation such Overhead expenses as wages or salary of personnel above the level of foreman (i.e., superintendents and project managers), expenses of Contractor's offices and supplies at the job site (e.g. job trailer) and at Contractor's principal place of business and including expenses of personnel staffing the job site office and Contractor's principal place of business, and Commercial General Liability Insurance and Automobile Liability Insurance.

OWNER, means Oregon State University (OSU). Owner may elect, by written notice to Contractor, to delegate certain duties to more than one party, including without limitation, to an Architect/Engineer. However, nothing in these General Conditions is intended to abrogate the separate design professional responsibilities of Architects under ORS Chapter 671 or of Engineers under ORS Chapter 672.

PERSON, means a natural person or entity doing business as a sole proprietorship, a partnership, a joint venture, a corporation, a limited liability company or partnership, or any other entity possessing the legal capacity to contract.

PLANS, means the drawings which show the location, type, dimensions, and details of the Work to be done under the Contract.

PROJECT, means the total design, development and construction of which the Work performed under the Contract Documents may be the whole or a part.

PUNCH LIST, means the list of Work yet to be completed or deficiencies which need to be corrected in order to achieve Final Completion of the Contract.

RECORD DOCUMENT, means the as-built Plans, Specifications, testing and inspection records, product data, samples, manufacturer and distributor/supplier warranties evidencing transfer of ownership to Owner, operational and maintenance manuals, shop drawings, Construction Change Directives, MWESB Reports, correspondence, certificate(s) of occupancy, and other documents listed in Subsection B.9.1 of these General Conditions, recording all Services performed.

SOLICITATION DOCUMENT, means a document used in a formal procurement soliciting two or more qualified sources by public notice for the same specifications and requirements

SPECIFICATION, means any description of the physical or functional characteristics of the Work, or of the nature of a supply, service or construction item. Specifications may include a description of any requirement for inspecting, testing or preparing a supply, service or construction item for delivery and the quantities or qualities of materials to be furnished under the Contract. Specifications generally will state the results or products to be obtained and may, on occasion, describe the method and manner of doing the Work to be performed. Specifications may be incorporated by reference and/or may be attached to the Contract.

SUBCONTRACT, means a contract between the Contractor and a subcontractor for the performance of a portion of the Work.

SUBCONTRACTOR, means a Person having a direct contract with the Contractor, or another Subcontractor, to perform one or more items of the Work.

SUBSTANTIAL COMPLETION, means the date when the Owner accepts in writing the construction, alteration or repair of the improvement to real property constituting the Work or any designated portion thereof as having reached that state of completion when it may be used or occupied for its intended purpose. Substantial Completion of facilities with operating systems occurs only after thirty (30) continuous Days of successful, trouble-free operation of the operating systems as provided in Section K.3.2.

SUBSTITUTIONS, means items that in function, performance, reliability, quality, and general configuration are the same or better than the product(s) specified. Approval of any substitute item shall be solely determined by the Owner. The decision of the Owner is final.

SUPPLEMENT, means a writing which, when fully executed by the Parties thereto, constitutes written agreement between the Owner and the Contractor comprised of the Contract Documents which describe the Work to be done and the obligations between the parties.

SUPPLEMENTAL GENERAL CONDITIONS, means those conditions that remove from, add to, or modify these General Conditions. Supplemental General Conditions may be included in the Solicitation Document or may be a separate attachment to the Contract.

WORK, means the furnishing of all materials, equipment, labor, transportation, services and incidentals necessary to successfully complete any individual item or the entire Contract and the carrying out of duties and obligations imposed by the Contract Documents.

A.2 SCOPE OF WORK

The Work contemplated under this Contract includes all labor, materials, transportation, equipment and services for, and incidental to, the completion of all construction work in connection with the project described in the Contract Documents. The Contractor shall perform all Work necessary so that the project can be legally occupied and fully used for the intended use as set forth in the Contract Documents.

A.3 INTERPRETATION OF CONTRACT DOCUMENTS

A.3.1 Unless otherwise specifically defined in the Contract Documents, words which have well-known technical meanings or construction industry meanings are used in the Contract Documents in accordance with such recognized meanings. Contract Documents are intended to be complementary. Whatever is called for in one is interpreted to be called for in all. However, in the event of conflicts or discrepancies among the Contract Documents, interpretations will be based on the following descending order of precedence:

- (a) Contract Supplements, Amendments and Construction Change Directives, with those of later date having precedence over those of an earlier date;
- (b) The Supplemental General Conditions;
- (c) General Conditions;
- (d) Purchase Orders;
- (e) Construction Change Directive;
- (f) Division One (General Requirements) of the Specifications;

- (g) Detailed Schedules of finishes, equipment and other items included in the Specifications;
- (h) Plans and Specifications (other than Division One and the Detailed Schedules to the Specifications);
- (i) Large-scale drawings on Plans;
- (j) Small-scale drawings on Plans;
- (k) Dimension numbers written on Plans which shall prevail and take precedence over dimensions scaled from Plans;
- (l) The Solicitation Document, and any addenda thereto;
- (m) The Master Contract.

A.3.2 In the case of an inconsistency between Plans and Specifications or within either document not clarified by addendum, the better quality or greater quantity of Work shall be provided in accordance with the Owner's interpretation in writing.

A.3.3 If the Contractor finds discrepancies in, or omissions from the Contract Documents, or if the Contractor is in doubt as to their meaning, the Contractor shall at once notify the Owner. Matters concerning and interpretation of requirements of the Contract Documents will be decided by the Owner, who may delegate that duty in some instances to the Architect/Engineer. Responses to Contractor's requests for interpretation of Contract Documents will be made in writing by Owner (or the Architect/Engineer) within any time limits agreed upon or otherwise with reasonable promptness. Interpretations and decisions of the Owner (or Architect/Engineer) will be consistent with the intent of and reasonably inferable from the Contract Documents. Contractor shall not proceed without direction in writing from the Owner (or Architect/Engineer).

A.3.4 References to standard specifications, manuals, codes of any technical society, organization or association, to the laws or regulations of any governmental authority, whether such reference be specific or by implication, shall mean the latest standard specification, manual, code, laws or regulations in effect in the jurisdiction where the project is occurring on the first published date of the Solicitation Document, except as may be otherwise specifically stated.

A.4 EXAMINATION OF PLANS, SPECIFICATIONS, AND SITE

A.4.1 It is understood that the Contractor, before submitting an Offer, has made a careful examination of the Contract Documents; has become fully informed as to the quality and quantity of materials and the character of the Work required; and has made a careful examination of the location and conditions of the Work and the sources of supply for materials. The Owner will in no case be responsible for any loss or for any unanticipated costs that may be suffered by the Contractor as a result of the Contractor's failure to acquire full information in advance in regard to all conditions pertaining to the Work. No oral agreement or conversation with any officer, agent, or personnel of the Owner, or with the Architect/Engineer either before or after the execution of this Contract, shall affect or modify any of the terms or obligations herein contained.

A.4.2 Should the Plans or Specifications fail to particularly describe the materials, kind of goods, or details of construction of any aspect of the Work, Contractor shall have the duty to make inquiry of the Owner and Architect/Engineer as to what is required prior to performance of the Work. Absent Specifications to the contrary, the materials or processes that would normally be used to produce first quality finished Work shall be considered a part of the Contract requirements.

A.4.3 Any design errors or omissions noted by the Contractor shall be reported promptly to the Owner, and confirmed in writing including without limitation, any nonconformity with Applicable Laws.

A.4.4 If the Contractor believes that adjustments to cost or Contract Time is involved because of clarifications or instructions issued by the Owner (or Architect/Engineer) in response to the Contractor's notices or requests for information, the Contractor must submit a written request to the Owner, setting forth the nature and specific extent of the request, including all time and cost impacts against the Contract as soon as possible, but no later than thirty (30) Days after receipt by Contractor of the clarifications or instructions issued. If the Owner denies Contractor's request for additional compensation, additional Contract Time, or other relief that Contractor believes results from the clarifications or instructions, the Contractor may proceed to file a Claim under Section D.3, Claims Review Process. If the Contractor fails to perform the obligations of Sections A.4.1 to A.4.3, the Contractor shall pay such costs and damages to the Owner as would have been avoided if the Contractor had performed such obligations.

A.5 INDEPENDENT CONTRACTOR STATUS

The service or services to be performed under this Contract are those of an independent contractor as defined in ORS 670.600. Contractor represents and warrants that it is not an officer, employee or agent of the Owner as those terms are used in ORS 30.265.

A.6 RETIREMENT SYSTEM STATUS AND TAXES

Contractor represents and warrants that it is not a contributing member of the Public Employees' Retirement System and will be responsible for any federal or state taxes applicable to payment received under this Contract. Contractor will not be eligible for any benefits from these Contract payments of federal Social Security, employment insurance, workers' compensation or the Public Employees' Retirement System, except as a self-employed individual. Unless the Contractor is subject to backup withholding, Owner will not withhold from such payments any amount(s) to cover Contractor's federal or state tax obligations.

A.7 GOVERNMENT EMPLOYMENT STATUS

A.7.1 If this payment is to be charged against federal funds, Contractor represents and warrants that it is not currently employed by the Federal Government. This does not preclude the Contractor from holding another contract with the Federal Government.

A.7.2 Contractor represents and warrants that Contractor is not an employee of the State of Oregon for purposes of performing Work under this Contract

**SECTION B
ADMINISTRATION OF THE CONTRACT**

B.1 OWNER'S ADMINISTRATION OF THE CONTRACT

B.1.1 The Owner shall administer the Contract as described in the Contract Documents (1) during construction (2) until Final Payment is due and (3) during the one-year period for correction of Work. The Owner will act as provided in the Contract Documents, unless modified in writing in accordance with other provisions of the Contract. In performing these tasks, the Owner may rely on the Architect/Engineer or other consultants to perform some or all of these tasks.

B.1.2 The Owner will visit the site at intervals appropriate to the stage of the Contractor's operations (1) to become generally familiar with and to keep the Owner informed about the progress and

quality of the portion of the Work completed, (2) to endeavor to guard the Owner against defects and deficiencies in the Work, and (3) to determine in general if Work is being performed in a manner indicating that the Work, when fully completed, will be in accordance with the Contract Documents. The Owner will not make exhaustive or continuous on-site inspections to check the quality or quantity of the Work. The Owner will neither have control over or charge of, nor be responsible for the construction means, methods, techniques, sequences or procedures, or for the safety precautions and programs in connection with the Work. Inspection of the progress, quantity, or quality of the Work done by the Owner, any Owner representative, and public agency, the Architect/Engineer, or any inspector, shall not relieve the Contractor of any responsibility for the compliance of all Work with the Contract Documents.

B.1.3 Except as otherwise provided in the Contract Documents or when direct communications have been specifically authorized, the Owner and Contractor shall communicate with each other about matters arising out of or relating to the Contract. Communications by and with the Architect/Engineer's consultants shall be through the Architect/Engineer. Communications by and with Subcontractors and material suppliers shall be through the Contractor. Communications by and with separate contractors shall be through the Owner.

B.1.4 Based upon the Architect/Engineer's evaluations of the Contractor's Application for Payment, or unless otherwise stipulated by the Owner, the Architect/Engineer will review and certify the amounts due the Contractor and will issue Certificates for Payment in such amounts.

B.2 CONTRACTOR'S MEANS AND METHODS; MITIGATION OF IMPACTS

B.2.1 The Contractor shall supervise and direct the Work, using the Contractor's best skill and attention. The Contractor shall be solely responsible for and have control over construction means, methods, techniques, sequences and procedures and for coordinating all portions of the Work under the Contract, unless the Contract Documents give other specific instructions concerning these matters. If the Contract Documents give specific instructions concerning construction means, methods, techniques, sequences or procedures, the Contractor shall evaluate the jobsite safety thereof and, except as stated below, shall be fully and solely responsible for the jobsite safety of such means, methods, techniques, sequences or procedures.

B.2.2 The Contractor is responsible to protect and maintain the Work during the course of construction and to mitigate any adverse impacts to the project, including those caused by authorized changes, which may affect cost, schedule, or quality.

B.2.3 The Contractor is responsible for the actions of all its personnel, laborers, suppliers, and Subcontractors on the project. The Contractor shall enforce strict discipline and good order among Contractor's employees and other persons carrying out the Work. The Contractor shall not permit employment of persons who are unfit or unskilled for the tasks assigned to them.

B.3 MATERIALS AND WORKMANSHIP

B.3.1 The intent of the Contract Documents is to provide for the construction and completion in every detail of the Work described. All Work shall be performed in a professional manner and unless the means or methods of performing a task are specified elsewhere in the Contract Documents, Contractor shall employ methods that are generally accepted and used by the industry, in accordance with industry standards.

B.3.2 The Contractor is responsible to perform the Work as required by the Contract Documents. Defective Work shall be corrected at the Contractor's expense.

B.3.3 Work done and materials furnished shall be subject to inspection and/or observation and testing by the Owner to determine if they conform to the Contract Documents. Inspection of the Work by the Owner does not relieve the Contractor of responsibility for the Work in accordance with the Contract Documents.

B.3.4 Contractor shall furnish adequate facilities, as required, for the Owner to have safe access to the Work including without limitation walkways, railings, ladders, tunnels, and platforms. Producers, suppliers, and fabricators shall also provide proper facilities and access to their facilities.

B.3.5 The Contractor shall furnish Samples of materials for testing by the Owner and include the cost of the Samples in the Contract Price.

B.4 PERMITS

Contractor shall obtain and pay for all necessary permits, licenses and fees, except for those specifically excluded in the Supplemental General Conditions, for the construction of the Work, for temporary obstructions, enclosures, opening of streets for pipes, walls, utilities, environmental Work, etc., as required for the project. Contractor shall be responsible for all violations of the law, in connection with the construction or caused by obstructing streets, sidewalks or otherwise. Contractor shall give all requisite notices to public authorities.

B.5 COMPLIANCE WITH GOVERNMENT REGULATIONS

B.5.1 Contractor shall comply with Applicable Laws pertaining to the Work and the Contract. Failure to comply with such requirements shall constitute a breach of Contract and shall be grounds for Contract termination. Without limiting the generality of the foregoing, Contractor expressly agrees to comply with the following, as applicable:

(i) Title VI and VII of Civil Rights Act of 1964, as amended; (ii) Section 503 and 504 of the Rehabilitation Act of 1973, as amended; (iii) the Health Insurance Portability and Accountability Act of 1996; (iv) the Americans with Disabilities Act of 1990, as amended; (v) ORS Chapters 659 and 659A; as amended; (vi) all regulations and administrative rules established pursuant to the foregoing laws; and (vii) all other applicable requirements of federal and state civil rights and rehabilitation statutes, rules and regulations.

B.5.2 Contractor shall comply with all applicable requirements of federal and state civil rights and rehabilitation statutes, rules and regulations, and

(a) Contractor shall not discriminate against Disadvantaged, Minority, Women or Emerging Small Business enterprises, as those terms are defined in ORS 200.005, or a business enterprise that is owned or controlled by or that employs a disabled veteran, as that term is defined in ORS 408.225, in the awarding of subcontracts.

(b) Contractor shall maintain, in current and valid form, all licenses and certificates required by Applicable Laws or this Contract when performing the Work.

B.5.3 Unless contrary to federal law, Contractor shall certify that it shall not accept a bid from Subcontractors to perform Work as described in ORS 701.005 under this Contract unless such Subcontractors are registered with the Construction Contractors Board in accordance with ORS 701.021 to 701.068 at the time they submit their bids to the Contractor.

B.5.4 Unless contrary to federal law, Contractor shall certify that each landscape contractor, as defined in ORS 671.520(2), performing Work under this Contract holds a valid landscape contractor's license issued pursuant to ORS 671.560.

B.5.5 The following notice is applicable to Contractors who perform excavation Work. ATTENTION: Oregon law requires you to follow rules adopted by the Oregon Utility Notification Center. Those rules are set forth in OAR 952-001-0010 through OAR 952-001-0100. You may obtain copies of the rules by calling the center at (503)232-1987.

B.5.6 Failure to comply with any or all of the requirements of B.5.1 through B.5.5 shall be a breach of Contract and constitute grounds for Contract termination. Damages or costs resulting from such noncompliance shall be the responsibility of Contractor.

B.6 SUPERINTENDENCE

Contractor shall keep on the site, during the progress of the Work, a competent superintendent and any necessary assistants who shall be satisfactory to the Owner and who shall represent the Contractor on the site. Directions given to the superintendent by the Owner shall be confirmed in writing to the Contractor.

B.7 INSPECTION

B.7.1 Owner shall have access to the Work at all times.

B.7.2 Inspection of the Work will be made by the Owner at its discretion. The Owner will have authority to reject Work that does not conform to the Contract Documents. Any Work found to be not in conformance with the Contract Documents, in the discretion of the Owner, shall be removed and replaced at the Contractor's expense.

B.7.3 Contractor shall make or obtain at the appropriate time all tests, inspections and approvals of portions of the Work required by the Contract Documents or by Applicable Laws or orders of public authorities having jurisdiction. Unless otherwise provided, the Contractor shall make arrangements for such tests, inspections and approvals with an independent testing laboratory or entity acceptable to the Owner, or with the appropriate public authority, and shall bear all related costs of tests, inspections and approvals. Tests or inspections conducted pursuant to the Contract Documents shall be made promptly to avoid unreasonable delay in the Work. The Contractor shall give the Owner timely notice of when and where tests and inspections are to be made so that the Owner may be present for such procedures. Required certificates of testing, inspection or approval shall, unless otherwise required by the Contract Documents, be secured by the Contractor and promptly delivered to the Owner.

B.7.4 As required by the Contract Documents, Work done or material used without required inspection or testing and/or without providing timely notice to the Owner may be ordered removed at the Contractor's expense.

B.7.5 If directed to do so any time before the Work is accepted, the Contractor shall uncover portions of the completed Work for inspection. After inspection, the Contractor shall restore such portions of Work to the standard required by the Contract. If the Work uncovered is unacceptable or was done without required testing or inspection or sufficient notice to the Owner, the uncovering and restoration shall be done at the Contractor's expense. If the Work uncovered is acceptable and was done with sufficient notice to the Owner, the uncovering and restoration will be paid for pursuant to a Supplement Amendment.

B.7.6 If any testing or inspection reveals failure of the portions of the Work to comply with requirements established by the Contract Documents, all costs made necessary by such failure, including those of repeated procedures and compensation for the Owner's and Architect/Engineer's services and expenses, shall be at the Contractor's expense.

B.7.7 When the United States government participates in the cost of the Work, or the Owner has an agreement with other public or private organizations, or if any portion of the Work is being performed for a third party or in close proximity to third party facilities, representatives of these organizations shall have the right to inspect the Work affecting their interests or property. Their right to inspect shall not make them a party to the Contract and shall not interfere with the rights of the parties of the Contract. Instructions or orders of such parties shall be transmitted to the Contractor, through the Owner.

B.8 SEVERABILITY

If any provision of this Contract is declared by a court to be illegal or in conflict with any law, the validity of the remaining terms and provisions shall not be affected and the rights and obligations of the parties shall be construed and enforced as if the Contract did not contain the particular provision held to be invalid.

B.9 ACCESS TO RECORDS

B.9.1 Contractor shall keep, at all times on the Work site, one record copy of the complete Contract Documents, including the Plans, Specifications, Construction Change Directives and addenda, in good order and marked currently to record field changes and selections made during construction, and one record copy of Shop Drawings, Product Data, Samples and similar submittals, and shall at all times give the Owner access thereto.

B.9.2 Contractor shall retain and the Owner and its duly authorized representatives shall have access, for a period not less than ten (10) years, to all Record Documents, financial and accounting records, and other books, documents, papers and records of Contractor which are pertinent to the Contract, including records pertaining to Overhead and indirect costs, for the purpose of making audit, examination, excerpts and transcripts. If for any reason, any part of the Work or this Contract shall be subject to litigation, Contractor shall retain all such records until all litigation is resolved and Contractor shall continue to provide Owner and/or its agents with full access to such records until such time as all litigation is complete and all periods for appeal have expired and full and final satisfaction of any judgment, order or decree is recorded and Owner receives a record copy of documentation from Contractor.

B.10 WAIVER

Failure of the Owner to enforce any provision of this Contract shall not constitute a waiver or relinquishment by the Owner of the right to such performance in the future nor of the right to enforce any other provision of this Contract.

B.11 SUBCONTRACTS AND ASSIGNMENT

B.11.1 Contractor shall require each Subcontractor, to the extent of the Work to be performed by the Subcontractor, to be bound by the terms and conditions of these General Conditions, and to assume toward the Contractor all of the obligations and responsibilities which the Contractor assumes toward the Owner thereunder, unless (1) the same are clearly inapplicable to the subcontract at issue because of legal requirements or industry practices, or (2) specific exceptions are requested by Contractor and approved in writing by Owner. Where appropriate, Contractor shall require each Subcontractor to

enter into similar agreements with sub-subcontractors at any level.

B.11.2 At Owner's request, Contractor shall submit to Owner prior to their execution either Contractor's form of subcontract, or the subcontract to be executed with any particular Subcontractor. If Owner disapproves such form, Contractor shall not execute the form until the matters disapproved are resolved to Owner's satisfaction. Owner's review, comment upon or approval of any such form shall not relieve Contractor of its obligations under this Agreement or be deemed a waiver of such obligations of Contractor.

B.11.3 Contractor shall not assign, sell, or transfer its rights, or delegate its responsibilities under this Contract, in whole or in part, without the prior written approval of the Owner. No such written approval shall relieve Contractor of any obligations of this Contract, and any transferee shall be considered the agent of the Contractor and bound to perform in accordance with the Contract Documents. Contractor shall remain liable as between the original parties to the Contract as if no assignment had occurred.

B.12 SUCCESSORS IN INTEREST

The provisions of this Contract shall be binding upon and shall accrue to the benefit of the parties to the Contract and their respective permitted successors and assigns.

B.13 OWNER'S RIGHT TO DO WORK

Owner reserves the right to perform other or additional work at or near the project site with other forces than those of the Contractor. If such work takes place within or next to the project site, Contractor shall coordinate work with the other contractors or forces, cooperate with all other contractors or forces, carry out the Work in a way that will minimize interference and delay for all forces involved, place and dispose of materials being used so as not to interfere with the operations of another, and join the Work with the work of the others in an acceptable manner and perform it in proper sequence to that of the others. The Owner will resolve any disagreements that may arise between or among Contractor and the other contractors over the method or order of doing all work (including the Work). In case of unavoidable interference, the Owner will establish work priority (including the Work) which generally will be in the sequence that the contracts were awarded.

B.14 OTHER CONTRACTS

In all cases and at any time, the Owner has the right to execute other contracts related to or unrelated to the Work of this Contract. The Contractor of this Contract shall fully cooperate with any and all other contractors without additional cost to the Owner in the manner described in section B.13.

B.15 GOVERNING LAW

This Contract shall be governed by and construed in accordance with the laws of the State of Oregon without regard to principles of conflict of laws.

B.16 LITIGATION

Any Claim between Owner and Contractor that arises from or relates to this Contract and that is not resolved through the Claims Review Process in Section D.3 shall be brought and conducted solely and exclusively within the Circuit Court of Benton County for the State of Oregon; provided, however, if a Claim must be brought in a federal forum, then it shall be brought and conducted solely and exclusively within the United States District Court for the District of Oregon. In no event shall this section be construed as a waiver by the State of Oregon of any form of defense or immunity, whether sovereign immunity,

governmental immunity, immunity based on the Eleventh Amendment to the Constitution of the United States or otherwise, from any claim or from the jurisdiction of any court. CONTRACTOR, BY EXECUTION OF THIS CONTRACT, HEREBY CONSENTS TO THE IN PERSONAM JURISDICTION OF THE COURTS REFERENCED IN THIS SECTION B.16.

B.17 ALLOWANCES

B.17.1 The Contractor shall include in the Contract Price all allowances stated in the Contract Documents. Items covered by allowances shall be supplied for such amounts and by such persons or entities as the Owner may direct.

B.17.2 Unless otherwise provided in the Contract Documents:

- (a) When finally reconciled, allowances shall cover the cost to the Contractor of materials and equipment delivered at the site and all required taxes, less applicable trade discounts;
- (b) Contractor's costs for unloading and handling at the site, labor, installation costs, Overhead, profit and other expenses contemplated for stated allowance amounts shall be included in the Contract Price but not in the allowances;
- (c) Whenever costs are more than or less than allowances, the Contract Price shall be adjusted accordingly by Amendment. The amount of the Amendment shall reflect (i) the difference between actual costs and the allowances under Section B.17.2(a) and (2) changes in Contractor's costs under Section B.17.2(b).
- (d) Unless Owner requests otherwise, Contractor shall provide to Owner a proposed fixed price for any allowance work prior to its performance.

B.18 SUBMITTALS, SHOP DRAWINGS, PRODUCT DATA AND SAMPLES

B.18.1 The Contractor shall prepare and keep current, for the Architect's/Engineer's approval (or for the approval of Owner if approval authority has not been delegated to the Architect/Engineer), a schedule and list of Submittals which is coordinated with the Contractor's construction schedule and allows the Architect/Engineer reasonable time to review Submittals. Owner reserves the right to finally approve the schedule and list of Submittals. Submittals include, without limitation, Shop Drawings, product data, and samples which are described below:

- (a) Shop Drawings are drawings, diagrams, schedules and other data specially prepared for the Work by the Contractor or a Subcontractor (including any sub-subcontractor), manufacturer, supplier or distributor to illustrate some portion of the Work.
- (b) Product Data are illustrations, standard schedules, performance charts, instructions, brochures, diagrams and other information furnished by the Contractor to illustrate materials or equipment for some portion of the Work.
- (c) Samples are physical examples which illustrate materials, equipment or workmanship and establish standards by which the Work will be judged.

B.18.2 Shop Drawings, Product Data, Samples and similar Submittals are not Contract Documents. The purpose of their Submittal is to demonstrate for those portions of the Work for which Submittals are required by the Contract Documents the way by which the Contractor proposes to conform to the information given and the design concept expressed in the Contract Documents. Review of Submittals by the Architect/Engineer is

not conducted for the purpose of determining the accuracy and completeness of other details such as dimensions and quantities, or for substantiating instructions for installation or performance of equipment or systems, or for approval of safety precautions or, unless otherwise specifically stated by the Architect/Engineer, of any construction means, methods, techniques, sequences or procedures, all of which remain the responsibility of the Contractor as required by the Contract Documents. The Architect/Engineer's review of the Contractor's Submittals shall not relieve the Contractor of its obligations under the Contract Documents. The Architect/Engineer's approval of a specific item shall not indicate approval of an assembly of which the item is a component. Informational Submittals upon which the Architect/Engineer is not expected to take responsive action may be so identified in the Contract Documents. Submittals which are not required by the Contract Documents may be returned by the Architect/Engineer without action.

B.18.3 The Contractor shall review for compliance with the Contract Documents, approve and submit to the Architect/Engineer Shop Drawings, Product Data, Samples and similar Submittals required by the Contract Documents with reasonable promptness and in such sequence as to cause no delay in the Work or in the activities of the Owner or of separate contractors. Submittals which are not marked as reviewed for compliance with the Contract Documents and approved by the Contractor may be returned by the Architect/Engineer without action.

B.18.4 Approving and submitting shop drawings, product data, samples and similar Submittals, the Contractor represents that the Contractor has determined and verified materials, field measurements and field construction criteria related thereto, or will do so, and has checked and coordinated the information contained within such Submittals with the requirements of the Work and of the Contract Documents.

B.18.5 The Contractor shall perform no portion of the Work for which the Contract Documents require submittal and review of Shop Drawings, Product Data, Samples or similar Submittals until the respective Submittal has been approved by the Architect/Engineer.

B.18.6 The Work shall be in accordance with approved Submittals except that the Contractor shall not be relieved of responsibility for deviations from requirements of the Contract Documents by the Architect/Engineer's review or approval of Shop Drawings, Product Data, Samples or similar Submittals unless the Contractor has specifically informed the Architect/Engineer in writing of such deviation at the time of submittal and (i) the Architect/Engineer has given written approval to the specific deviation as a minor change in the Work, or (ii) a Supplement Amendment or Construction Change Directive has been executed by Owner authorizing the deviation. The Contractor shall not be relieved of responsibility for errors or omissions in Shop Drawings, Product Data, Samples or similar Submittals by the Architect/Engineer's review or approval thereof.

B.18.7 In the event that Owner elects not to have the obligations and duties described under this Section B.18 performed by the Architect/Engineer, or in the event no Architect/Engineer is employed by Owner on the project, all obligations and duties assigned to the Architect/Engineer hereunder shall be performed by the Owner.

B.19 SUBSTITUTIONS

The Contractor may make Substitutions only with the written consent of the Owner, after evaluation by the Owner and only in accordance with a Supplement Amendment or Construction Change Directive. Substitutions shall be subject to the requirements of the bid

documents. By making requests for Substitutions, the Contractor represents that the Contractor has personally investigated the proposed substitute product; represents that the Contractor will provide the same warranty for the Substitution that the Contractor would for the product originally specified unless approved otherwise; certifies that the cost data presented is complete and includes all related costs under this Contract including redesign costs, and waives all claims for additional costs related to the Substitution which subsequently become apparent; and will coordinate the installation of the accepted Substitution, making such changes as may be required for the Work to be completed in all respects.

B.20 USE OF PLANS AND SPECIFICATIONS

Plans, Specifications and related Contract Documents furnished to Contractor by Owner or Owner's Architect/Engineer shall be used solely for the performance of the Work under this Contract. Contractor and its Subcontractors and suppliers are authorized to use and reproduce applicable portions of such documents appropriate to the execution of the Work, but shall not claim any ownership or other interest in them beyond the scope of this Contract, and no such interest shall attach. Unless otherwise indicated, all common law, statutory and other reserved rights, in addition to copyrights, are retained by Owner.

B.21 FUNDS AVAILABLE AND AUTHORIZED

If Owner fails to receive funding, appropriations, allocations or other expenditure authority as contemplated by Owner's budget and Owner determines, in its assessment and ranking of the policy objectives explicit or implicit in Owner's budget, Owner may determine it is necessary to and may terminate this Master Contract and or any Amendments.

B.22 NO THIRD PARTY BENEFICIARIES

Owner and Contractor are the only parties to this Contract and are the only parties entitled to enforce its terms. Nothing in this Contract gives, is intended to give, or shall be construed to give or provide any benefit or right, whether directly, indirectly, or otherwise, to third persons unless such third persons are individually identified by name herein and expressly described as intended beneficiaries of the terms of this Contract.

SECTION C WAGES AND LABOR

C.1 MINIMUM WAGE RATES ON PUBLIC WORKS

Contractor shall comply fully with the provisions of ORS 279C.800 through 279C.870. Documents establishing those conditions, as determined by the Commissioner of the Bureau of Labor and Industries (BOLI), are included as attachments to or are incorporated by reference in the Contract Documents. Pursuant to ORS 279C.830(1)(c), Contractor shall pay workers at not less than the specified minimum hourly rate of wage, and shall include that requirement in all subcontracts. If the Work is subject to both the state prevailing wage rate law and the federal Davis-Bacon Act, Contractor shall pay the higher of the applicable state or federal prevailing rate of wage. Contractor shall provide written notice to all workers of the number of hours per day and days per week such workers may be required to work.

C.2 PAYROLL CERTIFICATION AND FEE REQUIREMENTS

C.2.1 In accordance with ORS 279C.845, the Contractor and every Subcontractor shall submit written certified statements to the Owner, on the form prescribed by the Commissioner of the Bureau of Labor and Industries, certifying the hourly rate of wage paid each worker which the Contractor or the Subcontractor has employed on the project and further certifying that no worker employed on the project has been paid less than

the prevailing rate of wage or less than the minimum hourly rate of wage specified in the Contract, which certificate and statement shall be verified by the oath of the Contractor or the Subcontractor that the Contractor or Subcontractor has read the certified statement, that the Contractor or Subcontractor knows the contents of the certified statement, and, that to the Contractor's or Subcontractor's best knowledge and belief, the certified statement is true. The certified statements shall set out accurately and completely the payroll records for the prior week, including the name and address of each worker, the worker's correct classification, rate of pay, daily and weekly number of hours worked, deductions made, and actual wages paid. Certified statements for each week during which the Contractor or Subcontractor has employed a worker on the project shall be submitted once a month, by the fifth business day of the following month. The Contractor and Subcontractors shall preserve the certified statements for a period of ten (10) years from the date of completion of the Contract.

- C.2.2 Pursuant to ORS 279C.845(7), the Owner shall retain 25 percent of any amount earned by the Contractor on this public works project until the Contractor has filed the certified statements required by section C.2.1. The Owner shall pay to the Contractor the amount retained under this subsection within 14 days after the Contractor files the required certified statements, regardless of whether a Subcontractor has failed to file certified statements.
- C.2.3 Pursuant to ORS 279C.845(8), the Contractor shall retain 25 percent of any amount earned by a first-tier Subcontractor on this public works project until the first-tier Subcontractor has filed with the Owner the certified statements required by C.2.1. Before paying any amount retained under this subsection, the Contractor shall verify that the first-tier Subcontractor has filed the certified statement. Within 14 days after the first-tier Subcontractor files the required certified statement the Contractor shall pay the first-tier Subcontractor any amount retained under this subsection.
- C.2.4 In accordance with statutory requirements and administrative rules promulgated by the Commissioner of the Bureau of Labor and Industries, the fee required by ORS 279C.825(1) will be paid by Owner to the Commissioner.

C.3 PROMPT PAYMENT AND CONTRACT CONDITIONS

- C.3.1 As a condition to Owner's performance hereunder, the Contractor shall:
- C.3.1.1 Make payment promptly, as due, to all persons supplying to Contractor labor or materials for the prosecution of the Work provided for in this Contract.
- C.3.1.2 Pay all contributions or amounts due the State Industrial Accident Fund from such Contractor or Subcontractor incurred in the performance of the Contract.
- C.3.1.3 Not permit any lien or claim to be filed or prosecuted against the Owner on account of any labor or material furnished. Contractor will not assign any claims that Contractor has against Owner, or assign any sums due by Owner, to Subcontractors, suppliers, or manufacturers, and will not make any agreement or act in any way to give Subcontractors a claim or standing to make a claim against the Owner.
- C.3.1.4 Pay to the Department of Revenue all sums withheld from employees pursuant to ORS 316.167.
- C.3.2 As a condition to Owner's performance hereunder, if Contractor fails, neglects or refuses to make prompt payment of any claim for labor or services furnished to the Contractor of a

Subcontractor by any person in connection with the project as such claim becomes due, the proper officer(s) representing the Owner may pay the claim and charge the amount of the payment against funds due or to become due Contractor under this Contract. Payment of claims in this manner shall not relieve the Contractor or the Contractor's surety from obligation with respect to any unpaid claims.

- C.3.3 Contractor shall include in each subcontract for property or services entered into by the Contractor and a first-tier subcontractor, including a material supplier, for the purpose of performing a construction contract, a payment clause that obligates the Contractor to pay the first-tier Subcontractor for satisfactory performance under its subcontract within ten (10) Days out of such amounts as are paid to the Contractor by the public contracting agency under such contract.
- C.3.4 All employers, including Contractor, that employ subject workers who work under this contract in the State of Oregon shall comply with ORS 656.017 and provide the required Workers' Compensation coverage, unless such employers are exempt under ORS 656.126. Contractor shall ensure that each of its Subcontractors complies with these requirements.

C.4 PAYMENT FOR MEDICAL CARE

As a condition to Owner's performance hereunder, Contractor shall promptly, as due, make payment to any person, partnership, association or corporation furnishing medical, surgical, and hospital care or other needed care and attention, incident to sickness or injury, to the employees of such Contractor, all sums of which the Contractor agrees to pay for such services and all moneys and sums which the Contractor has collected or deducted from the wages of personnel pursuant to any law, contract or agreement for the purpose of providing or paying for such services.

C.5 HOURS OF LABOR

As a condition to Owner's performance hereunder, no person shall be employed to perform Work under this Contract for more than ten (10) hours in any one day or forty (40) hours in any one week, except in cases of necessity, emergency or where public policy absolutely requires it. In such instances, Contractor shall pay the employee at least time and a half pay:

- (a) For all overtime in excess of eight (8) hours a day or forty (40) hours in any one week when the work week is five consecutive Days, Monday through Friday; or
- (b) For all overtime in excess of ten (10) hours a day or forty (40) hours in any one week when the work week is four consecutive Days, Monday through Friday; and
- (c) For all Work performed on Saturday and on any legal holiday specified in ORS 279C.540.

This section C.5 will not apply to Contractor's Work under this Contract to the extent Contractor is currently a party to a collective bargaining agreement with any labor organization.

This Section C.5 shall not excuse Contractor from completion of the Work within the time required under this Contract.

SECTION D CHANGES IN THE WORK

D.1 CHANGES IN WORK

- D.1.1 The terms of this Contract shall not be waived, altered, modified, supplemented or amended in any manner whatsoever, without prior written agreement and then only after any necessary approvals have been obtained. A Supplement or Amendment is

required, which shall not be effective until its execution by the parties to this Contract and all approvals required by public contracting laws have been obtained.

D.1.2 It is mutually agreed that changes in Plans, quantities, or details of construction are inherent in the nature of construction and may be necessary or desirable during the course of construction. Within the general scope of this Contract, the Owner may at any time, without notice to the sureties and without impairing the Contract, require changes consistent with this Section D.1. All changes to the Work shall be documented and Amendments shall be executed under the conditions of the Contract Documents. Such changes may include, but are not limited to:

- (a) Modification of specifications and design.
- (b) Increases or decreases in quantities.
- (c) Increases or decreases to the amount of Work.
- (d) Addition or elimination of any Work item.
- (e) Change in the duration of the project.
- (f) Acceleration or delay in performance of Work.
- (g) Deductive changes,
- (h) Changed conditions.

Deductive changes are those that reduce the scope of the Work, and shall be made by mutual agreement whenever feasible. In cases of suspension or partial termination under Section J, Owner reserves the right to unilaterally impose a deductive change and to self-perform such Work, for which the provisions of B.13 (Owner's Right to Do Work) shall then apply. Adjustments in compensation shall be made under the provisions of D.1.3, in which costs for deductive changes shall be based upon a Direct Costs adjustment together with the related percentage markup specified for profit, Overhead and other indirect costs, unless otherwise agreed to by Owner.

D.1.3 The Owner and Contractor agree that adjustments to or deletions from the Work shall be administered and compensated according to the following:

- (a) Unit pricing may be utilized at the Owner's option when unit prices or solicitation alternates were provided that established the cost for adjustments to Work, and a binding obligation exists under the Contract on the parties covering the terms and conditions of the adjustment to Work.
- (b) If the Owner elects not to utilize unit pricing, or in the event that unit pricing is not available or appropriate, fixed pricing may be used for adjustments to or deletions from the Work. In fixed pricing, the basis of payments or total price shall be agreed upon in writing between the parties to the Contract, and shall be established before the Work is done whenever feasible. Notwithstanding the foregoing, the mark-ups set forth in D.1.3(c) shall be utilized in establishing fixed pricing, and such mark-ups shall not be exceeded. Cost and price data relating to adjustments to or deletions from the Work shall be supplied by Contractor to Owner upon request, but Owner shall be under no obligation to make such requests.
- (c) In the event that unit pricing and fixed pricing are not utilized, then adjustments to or deletions from the Work shall be performed on a cost reimbursement basis for Direct Costs. Such Work shall be compensated on the basis of the actual, reasonable and allowable cost of labor, equipment, and material furnished on the Work performed. In addition, the following markups shall be added to the Contractor's or Subcontractor's Direct Costs as full compensation for profit, Overhead and other indirect costs for Work directly performed with the Contractor's or Subcontractor's own forces:

On Labor.....	15%
On Equipment.....	10%

On Materials..... 10%

- (d) When adjustments to or deletions from the Work under D.1.3(c) are invoiced by an authorized Subcontractor at any level, each ascending tier Subcontractor or Contractor will be allowed a supplemental mark-up on each piece of subcontract Work covered by an Amendment as follows:

\$0.00 - \$5,000.00	10%, and then
Over \$5,000.00	5%

Notwithstanding the foregoing, the maximum aggregate markup to be billed shall not exceed 10% regardless of the number of subcontract tiers

Payments made to the Contractor shall be complete compensation for Overhead, profit, and all costs that were incurred by the Contractor or by other forces furnished by the Contractor, including Subcontractors, for adjustments to or deletions from the Work pursuant to a Supplement Amendment. Owner may establish a maximum cost for additional Work under this Section D.1.3, which shall not be exceeded for reimbursement without additional written authorization from Owner in the form of a Supplement Amendment. Contractor shall not be required to complete such additional Work without additional authorization.

Any necessary adjustment of Contract Time that may be required as a result of adjustments to or deletions from the Work must be agreed upon by the parties before the start of the revised Work unless Owner authorizes Contractor to start the revised Work before agreement on Contract Time adjustment. Contractor shall submit any request for additional compensation (and additional Contract Time if Contractor was authorized to start Work before an adjustment of Contract Time was approved) as soon as possible but no later than thirty (30) Days after receipt of Owner's request for additional Work. Contractor agrees that this thirty (30) Day notice period is adequate time for it to request and document the amount of additional compensation or adjustment of Contract Time. If Contractor's request for additional compensation or adjustment of Contract Time is not made within the thirty (30) Day time limit, Contractor agrees its requests pertaining to that additional Work shall be barred. The thirty (30) Day time limit for making requests shall not be extended for any reason, including without limitation Contractor's claimed inability to determine the amount of additional compensation or adjustment of Contract Time, unless an extension is granted in writing by Owner. If the Owner denies Contractor's timely request for additional compensation or adjustment of Contract Time, Contractor may proceed to file a Claim under Section D.3, Claims Review Process. No other reimbursement, compensation, or payment will be made, except as provided in Section D.1.5 for impact claims.

- D.1.4 If any adjustment to Work under Section D.1.3 causes an increase or decrease in the Contractor's cost of, or the Contract Time required for the performance of any other part of the Work under this Contract, Contractor shall submit a written request to the Owner, setting forth the nature and specific extent of the request, including all time and cost impacts against the Contract as soon as possible, but no later than thirty (30) Days after receipt of Owner's request for adjustments to or deletions from the Work by Contractor.

The thirty (30) Day time limit applies to claims of Subcontractors, suppliers, or manufacturers who may be affected by Owner's request for adjustments to or deletions from the Work and who request additional compensation or an extension of Contract Time to perform; Contractor has responsibility for contacting its Subcontractors, suppliers, or

manufacturers within the thirty (30) Day time limit, and including their requests with Contractor's requests. If the request involves Work to be completed by Subcontractors, or materials to be furnished by suppliers or manufacturers, such requests shall be submitted to the Contractor in writing with full analysis and justification for the adjustments to compensation and Contract Time requested. The Contractor shall analyze and evaluate the merits of the requests submitted by Subcontractors, suppliers, and manufacturers to Contractor prior to including those requests and Contractor's analysis and evaluation of those requests with Contractor's requests for adjustments to compensation or Contract Time that Contractor submits to the Owner. Failure of Subcontractors, suppliers, manufacturers or others to submit their requests to Contractor for inclusion with Contractor's requests submitted to Owner within the time period and by the means described in this section shall constitute a waiver of these Subcontractor claims. The Owner will not consider direct requests or claims from Subcontractors, suppliers, manufacturers or others not a party to this Contract. The consideration of such requests and claims under this section does not give any Person, not a party to the Contract the right to bring a claim against Owner, whether in this claims process, in litigation, or in any dispute resolution process.

If the Owner denies the Contractor's request for adjustment to compensation or Contract Time, and the request is timely as set forth herein, the Contractor may proceed to file a Claim under Section D.3, Claims Review Process.

D.1.5 Contractor agrees that no request or Claim for additional costs or an adjustment of Contract Time shall be allowed if made after receipt of Final Payment application under this Contract. Final Payment application must be made by Contractor within the time required under Section E.6.4.

D.1.6 It is understood that changes in the Work are inherent in construction of this type. The number of changes, the scope of those changes, and the effect they have on the progress of the original Work cannot be defined at this time. The Contractor is notified that numerous changes may be required and that there will be no compensation made, unless and only to the extent otherwise provided in the Contract Documents, to the Contractor directly related to the number of changes. Each change will be evaluated for extension of Contract Time and increase or decrease in compensation based on its own merit.

D.2 DELAYS

D.2.1 Delays in construction include "Avoidable Delays", which are defined in Section D.2.1.1, and "Unavoidable Delays", which are defined in Section D.2.1.2. The effect of Avoidable Delays is described in Section D.2.2 and the effect of Unavoidable Delays is described in Section D.2.3.

D.2.1.1 Avoidable Delays include any delays other than Unavoidable Delays, and include delays that otherwise would be considered Unavoidable Delays but that:

- (a) Could have been avoided by the exercise of care, prudence, foresight, and diligence on the part of the Contractor or its Subcontractors.
- (b) Affect only a portion of the Work and do not necessarily prevent or delay the prosecution of other parts of the Work or the completion of the whole Work within the Contract Time.
- (c) Do not impact activities on the accepted CPM Construction Schedule.
- (d) Are associated with the reasonable interference of other contractors employed by the Owner that do not necessarily

prevent the completion of the whole Work within the Contract Time.

D.2.1.2 Unavoidable Delays include delays other than Avoidable Delays that are:

- (a) To the extent caused by any actions of the Owner, or any other employee or agent of the Owner, or by separate contractor employed by the Owner.
- (b) To the extent caused by any site conditions that differ materially from what was represented in the Contract Documents or from conditions that would normally be expected to exist and be inherent to the construction activities defined in the Contract Documents. The Contractor agrees to notify the Owner immediately of differing site conditions before the area has been disturbed. The Owner will investigate the area and make a determination as to whether the conditions differ materially from either the conditions stated in the Contract Documents or those that could reasonably be expected in execution of this particular Contract. If Contractor and Owner agree that a differing site condition exists, any adjustment to compensation or Contract Time will be determined based on the process set forth in Section D.1.5 for adjustments to or deletions from Work. If the Owner disagrees that a differing site condition exists and denies Contractor's request for additional compensation or Contract Time, Contractor may proceed to file a Claim under Section D.3, Claims Review Process.
- (c) To the extent caused by Force Majeure acts, events or occurrences that could not have been avoided by the exercise of care, prudence, foresight, and diligence on the part of the Contractor or its Subcontractors.
- (d) To the extent caused by adverse weather conditions. Any adverse weather conditions must be substantiated by documentary evidence that weather conditions were abnormal for the specific time period claimed, could not have been anticipated by the Contractor, and adversely impacted the Project in a manner that could not be avoided by rescheduling the Work or by implementing measures to protect against the weather so that the Work could proceed. A rain, windstorm, high water, or other natural phenomenon for the specific locality of the Work, which might reasonably have been anticipated from the previous 10-year historical records of the general locality of the Work, shall not be construed as abnormal. The parties agree that rainfall greater than the following levels cannot be reasonably anticipated:

- (i) Daily rainfall equal to, or greater than, 0.50 inch during a month when the monthly rainfall exceeds the normal monthly average by twenty-five percent (25 %) or more.
- (ii) daily rainfall equal to, or greater than, 0.75 inch at any time.

The Office of the Environmental Data Service of the National Oceanic and Atmospheric Administration of the U.S. Department of Commerce nearest the Project site shall be considered the official agency of record for weather information.

D.2.2 Contractor agrees it is not be entitled to additional compensation or additional Contract Time for Avoidable Delays.

D.2.3 In the event of Unavoidable Delays, based on principles of equitable adjustment, Contractor may be entitled to the following:

- (a) Contractor may be entitled to additional compensation or additional Contract Time, or both, for Unavoidable Delays described in Section D.2.1.2 (a) and (b).
- (b) Contractor may be entitled to additional Contract Time for Unavoidable Delays described in Section D.2.1.2(c) and (d).

In the event of any requests for additional compensation or additional Contract Time, or both, as applicable, arising under this Section D.2.3 for Unavoidable Delays, other than requests for additional compensation or additional Contract Time for differing site conditions for which a review process is established under Section D.2.1.2 (b), Contractor must submit a written notification of the delay to the Owner within two (2) Days of the occurrence of the cause of the delay. This written notification shall state the cause of the potential delay, the project components impacted by the delay, and the anticipated additional Contract Time extension or the additional compensation, or both, as applicable, resulting from the delay. Within seven (7) Days after the cause of the delay has been mitigated, or in no case more than thirty (30) Days after the initial written notification, the Contractor agrees to submit to the Owner, a complete and detailed request for additional compensation or additional Contract Time, or both, as applicable, resulting from the delay. If the Owner denies Contractor's request for additional compensation or adjustment of Contract Time, the Contractor may proceed to file a Claim under Section D.3, Claims Review Process, provided Contractor has complied with the requirement in this Section D.2.3. Contractor agrees any Claim it may have is barred if Contractor does not comply with the requirements herein.

If Contractor does not timely submit the notices required under this Section D.2, then unless otherwise prohibited by law, Contractor's Claim shall be barred.

D.3 CLAIMS REVIEW PROCESS

- D.3.1 All Contractor Claims shall be referred to the Owner for review. Contractor's Claims, including Claims for adjustments to compensation or Contract Time, shall be submitted in writing by Contractor to the Owner within five (5) Days after a denial of Contractor's initial request for an adjustment of Contract terms, payment of money, extension of Contract Time or other relief, provided that such initial request has been submitted in accordance with the requirements and within the time limits established in these General Conditions. Within thirty (30) Days after the initial Claim, Contractor shall submit to the Owner a complete and detailed description of the Claim (the "Detailed Notice") that includes all information required by Section D.3.2. Contractor agrees that, unless the Claim is made in accordance with these time requirements, Contractor voluntarily waived all rights to prosecute its Claim.
- D.3.2 The Detailed Notice of the Claim shall be submitted in writing by Contractor and shall include a detailed, factual statement of the basis of the Claim, pertinent dates, Contract provisions which support or allow the Claim, reference to or copies of any documents which support the Claim, the dollar value of the Claim, and the Contract Time adjustment requested for the Claim. If the Claim involves Work to be completed by Subcontractors, the Contractor will analyze and evaluate the merits of the Subcontractor claim prior to forwarding it and that analysis and evaluation to the Owner. The Owner will not consider direct claims from Subcontractors, suppliers, manufacturers, or others not a party to this Contract. Contractor agrees that it will make no agreement, covenant, or assignment, nor will it commit any other act that will permit or assist any Subcontractor, supplier, manufacturer, or other to directly or indirectly make a claim against Owner.

- D.3.3 The Owner will review all Claims and take one or more of the following preliminary actions within ten (10) Days of receipt of the Detailed Notice of a Claim: (1) request additional supporting information from the Contractor; (2) inform the Contractor and Owner in writing of the time required for adequate review and response; (3) reject the Claim in whole or in part and identify the reasons for rejection; (4) based on principles of equitable adjustment, recommend approval of all or part of the Claim; or (5) propose an alternate resolution.
- D.3.4 The Owner's decision shall be final and binding on the Contractor unless appealed by written notice to the Owner within fifteen (15) Days of receipt of the decision. The Contractor must present written documentation supporting the Claim within fifteen (15) Days of the notice of appeal. After receiving the appeal documentation, the Owner shall review the materials and render a decision within thirty (30) Days after receiving the appeal documents.
- D.3.5 The decision of the Owner shall be final and binding unless the Contractor delivers to the Owner its request for mediation, which shall be a non-binding process, within fifteen (15) Days of the date of the Owner's decision. The mediation process will be considered as having commenced as of the date the Contractor delivers the request. Both parties acknowledge and agree that participation in mediation is a prerequisite to commencement of litigation of any disputes relating to the Contract. Both parties further agree to exercise their best efforts in good faith to resolve all disputes within sixty (60) Days of the commencement of the mediation through the mediation process set forth herein.

In the event that a lawsuit must be filed within this sixty (60) Day period in order to preserve a cause of action, the parties agree that, notwithstanding the filing, they shall proceed diligently with the mediation to its conclusion prior to actively prosecuting the lawsuit, and shall seek from the Court in which the lawsuit is pending such stays or extensions, including the filing of an answer, as may be necessary to facilitate the mediation process. Further, in the event settlements are reached on any issues through mediation, the plaintiff shall promptly cause to be entered by the Court a stipulated general judgment of dismissal with prejudice, or other appropriate order limiting the scope of litigation as provided in the settlement.

- D.3.6 Should the parties arrive at an impasse regarding any Claims or disputed Claims, it is agreed that the parties shall participate in mediation as specified in Section D.3.5. The mediation process will be considered to have been commenced as of the date one party delivers to the other its request in writing to mediate. The mediator shall be an individual mutually acceptable to both parties, but in the absence of agreement each party shall select a temporary mediator and the temporary mediators shall jointly select the permanent mediator. Each party shall pay its own costs for the time and effort involved in mediation. The cost of the mediator shall be split equally between the two parties. Both parties agree to exercise their best effort in good faith to resolve all disputes in mediation. Participation in mediation is a mandatory requirement of both the Owner and the Contractor. The schedule, time and place for mediation will be mutually acceptable, or, failing mutual agreement, shall be as established by the mediator. The parties agree to comply with Owner's administrative rules governing the confidentiality of mediation, if any, and shall execute all necessary documents to give effect to such confidentiality rules. In any event, the parties shall not subpoena the mediator or otherwise require the mediator to produce records, notes or work product, or to testify in any future proceedings as to information disclosed or representations made in the course of mediation, except to the extent disclosure is required by law.

D.3.7 Unless otherwise directed by Owner, Contractor shall proceed with the Work while any Claim, or mediation or litigation arising from a Claim, is pending. Regardless of the review period or the final decision of the Owner, the Contractor shall continue to diligently pursue the Work as identified in the Contract Documents. In no case is the Contractor justified or allowed to cease or Delay Work, in whole or in part, without a written stop work order from the Owner.

SECTION E PAYMENTS

E.1 SCHEDULE OF VALUES

The Contractor shall submit, at least ten (10) Days prior to submission of its first application for progress payment, a schedule of values ("Schedule of Values") for the contracted Work. This schedule shall provide a breakdown of values for the contracted Work and will be the basis for progress payments. The breakdown shall demonstrate reasonable, identifiable, and measurable components of the Work. Unless objected to by the Owner, this schedule shall be used as the basis for reviewing Contractor's applications for payment. If objected to by Owner, Contractor shall revise the schedule of values and resubmit the same for approval of Owner.

E.2 APPLICATIONS FOR PAYMENT

E.2.1 Owner shall make progress payments on the Contract monthly as Work progresses, in accordance with the requirements of this Section E.2. Applications for payment shall be based upon estimates of Work completed and the Schedule of Values. As a condition precedent to Owner's obligation to pay, all applications for payment shall be approved by the Owner. A progress payment shall not be considered acceptance or approval of any Work or waiver of any defects therein. Owner shall pay to Contractor interest for overdue invoices at the rate of two-thirds of one percent per month on the progress payment, not including retainage, due the Contractor. Overdue invoices will be those that have not been paid within forty five (45) days from the latest of:

- (a) The date of the receipt of the accurate invoice;
- (b) The date Owner receives the correct application for payment if no invoice is received;
- (c) The date all goods and services have been received; or
- (d) The date a Claim is made certain by agreement of the parties or by operation of law.

Notwithstanding the foregoing, in instances when an application for payment is filled out incorrectly, or when there is any defect or impropriety in any submitted application or when there is a good faith dispute, Owner shall so notify the Contractor within fifteen (15) Days stating the reason or reasons the application for payment is defective or improper or the reasons for the dispute. A defective or improper application for payment, if corrected by the Contractor within seven (7) Days of being notified by the Owner, shall not cause a payment to be made later than specified in this section unless interest is also paid. Payment of interest will be postponed when payment on the principal is delayed because of disagreement between the Owner and the Contractor.

Owner reserves the right, instead of requiring the Contractor to correct or resubmit a defective or improper application for payment, to reject the defective or improper portion of the application for payment and pay the remainder of the application for such amounts which are correct and proper.

Owner, upon written notice to the Contractor, may elect to make payments to the Contractor only by means of Electronic Funds

Transfers (EFT) through Automated Clearing House (ACH) payments. If Owner makes this election, the Contractor shall arrange for receipt of the EFT/ACH payments.

E.2.2 Contractor shall submit to the Owner an application for each payment and, if required, receipts or other vouchers showing payments for materials and labor including payments to Subcontractors. Contractor shall include in its application for payment a schedule of the percentages of the various parts of the Work completed, based on the Schedule of Values which shall aggregate to the payment application total, and shall include, on the face of each copy thereof, a certificate in substantially the following form:

"I, the undersigned, hereby certify that the above bill is true and correct, and the payment therefore, has not been received.

Signed: _____
Dated: _____"

E.2.3 Generally, applications for payment will be accepted only for materials that have been installed. Under special conditions, applications for payment for stored materials will be accepted at Owner's sole discretion. Such a payment, if made, will be subject to the following conditions:

- (a) The request for stored material shall be submitted at least thirty (30) Days in advance of the application for payment on which it appears. Applications for payment shall be entertained for major equipment, components or expenditures only.
- (b) The Contractor shall submit applications for payment showing the quantity and cost of the material stored.
- (c) The material shall be stored in a bonded warehouse and Owner shall be granted the right to access the material for the purpose of removal or inspection at any time during the Contract Period.
- (d) The Contractor shall name the Owner as co-insured on the insurance policy covering the full value of the property while in the care and custody of the Contractor until it is installed. A certificate noting this coverage shall be issued to the Owner.
- (e) Payments shall be made for materials and equipment only. The submitted amount in the application for payment shall be reduced by the cost of transportation from the storage site to the project site and for the cost of an inspector to verify delivery and condition of the goods at the storage site. The cost of storage and inspection shall be borne solely by the Contractor.
- (f) Within sixty (60) Days of the application for payment, the Contractor shall submit evidence of payment covering the material and/or equipment stored and of payment for the storage site.
- (g) Payment for stored materials and/or equipment shall in no way indicate acceptance of the materials and/or equipment or waive any rights under this Contract for the rejection of the Work or materials and/or equipment not in conformance with the Contract Documents.
- (h) All required documentation shall be submitted with the respective application for payment.

E.2.4 The Owner reserves the right to withhold all or part of a payment, or may nullify in whole or part any payment previously made, to such extent as may be necessary in the Owner's opinion to protect the Owner from loss because of:

- (a) Work that is defective and not remedied, or that has been demonstrated or identified as failing to conform with Applicable Laws or the Contract Documents,
- (b) Third party claims filed or evidence reasonably indicating that such claims will likely be filed unless security acceptable to the Owner is provided by the Contractor;
- (c) Failure of the Contractor to make payments properly to Subcontractors or for labor, materials or equipment (in which case Owner may issue checks made payable jointly to Contractor and such unpaid persons under this provision, or directly to Subcontractors and suppliers at any level under Section C.3.2.);
- (d) Reasonable evidence that the Work cannot be completed for the unpaid balance of the Contract Price;
- (e) Damage to the Work, Owner or another contractor;
- (f) Reasonable evidence that the Work will not be completed within the Contract Time required by the Contract, and that the unpaid balance would not be adequate to cover actual or liquidated damages for the anticipated delay;
- (g) Failure to carry out the Work in accordance with the Contract Documents; or
- (h) Assessment of liquidated damages, when withholding is made for offset purposes.

E.2.5 Subject to the provisions of the Contract Documents, the amount of each progress payment shall be computed as follows:

- (a) Take that portion of the Contract Price properly allocable to completed Work as determined by multiplying the percentage completion of each portion of the Work by the share of the total Contract Price allocated to that portion of the Work in the Schedule of Values, less retainage as provided in Section E.5. Pending final determination of cost to the Owner of changes in the Work, no amounts for changes in the Work can be included in applications for payment until the Contract Price has been adjusted by a Supplement Amendment;
- (b) Add that portion of the Contract Price properly allocable to materials and equipment delivered and suitably stored at the site for subsequent incorporation in the completed construction (or, if approved in advance by the Owner pursuant to Section E.2.3, suitably stored off the site at a location agreed upon in writing), less retainage as provided in Section E.5;
- (c) Subtract the aggregate of previous payments made by the Owner; and
- (d) Subtract any amounts for which the Owner has withheld or nullified payment as provided in the Contract Documents.

E.2.6 Contractor's applications for payment shall not include requests for payment for portions of the Work for which the Contractor does not intend to pay to a Subcontractor or material supplier.

E.2.7 The Contractor warrants to Owner that title to all Work covered by an application for payment will pass to the Owner no later than the time of payment. The Contractor further warrants that upon submittal of an application for payment all Work for which payments are received from the Owner shall be free and clear of liens, claims, security interests or encumbrances in favor of the Contractor, Subcontractors, material suppliers, or other persons or entities making a claim by reason of having provided financing, labor, materials and equipment relating to the Work.

E.2.8 If Contractor disputes any determination by Owner with regard to any application for payment, Contractor nevertheless shall continue to expeditiously perform the Work. No payment made hereunder shall be or be construed to be final acceptance or approval of that portion of the Work to which such partial payment relates or shall relieve Contractor of any of its obligations hereunder.

E.2.9 Contractor shall submit its initial MWESB Report within ten (10) Days of Contractor's execution of the Contract. Contractor shall submit annual MWESB Reports on June 30 of each year the Contract is active. Contracts first executed by Contractor within ninety (90) Days before June 30 of the year of execution by Contractor may at the discretion of Owner be exempt from submitting the annual MWESB Report otherwise due on that June 30. The final MWESB Report shall be filed with the application for final payment. Timely receipt of MWESB Reports by Owner shall be a condition precedent to Owner's obligation to pay any progress payments or final payment otherwise due.

E.3 PAYROLL CERTIFICATION REQUIREMENT

Owner's receipt of payroll certification pursuant to Section C.2 of this Contract shall be a condition precedent to Owner's obligation to pay any progress payments or final payment otherwise due.

E.4 DUAL PAYMENT SOURCES

Contractor shall not be compensated for Work performed under this Contract from any state agency other than the agency that is a party to this Contract.

E.5 RETAINAGE

E.5.1 Retainage shall be withheld and released in accordance with the requirements set forth in OSU Standards.

E.5.1.1 Owner may reserve as retainage from any progress payment an amount not to exceed five percent of the payment. As Work progresses, Owner may reduce the amount of retainage on or may eliminate retainage on any remaining monthly Contract payments after 50 percent of the Work under the Contract is completed if, in the Owner's discretion, such Work is progressing satisfactorily. Elimination or reduction of retainage shall be allowed only at Owner's sole discretion and only upon written application by the Contractor, which application shall include written approval of Contractor's surety; except that when the Work is 97-1/2 percent completed the Owner may, at its discretion and without application by the Contractor, reduce the retained amount to 100 percent of the value of the Work remaining to be done. Upon receipt of written application by the Contractor, Owner shall respond in writing within a reasonable time.

E.5.1.2 Contractor may request in writing:

- (a) To be paid amounts which would otherwise have been retained from progress payments where Contractor has deposited acceptable bonds and securities of equal value with Owner or in a custodial account or other mutually-agreed account satisfactory to Owner, with an approved bank or trust company to be held in lieu of the cash retainage for the benefit of Owner;
- (b) For construction projects over \$1,000,000, that retainage be deposited in an interest bearing account, established through the State Treasurer for state agencies, in a bank, savings bank, trust company or savings association for the benefit of Owner, with earnings from such account accruing to the Contractor; or

- (c) That the Owner allow Contractor to deposit a surety bond for the benefit of Owner, in a form acceptable to Owner, in lieu of all or a portion of funds retained, or to be retained. Such bond and any proceeds therefrom shall be made subject to all claims in the manner and priority as set forth for retainage.

When the Owner has accepted the Contractor's election of option (a) or (b), Owner may recover from Contractor any additional costs incurred through such election by reducing Contractor's final payment. Where the Owner has agreed to Contractor's request for option (c), Contractor shall accept like bonds from Subcontractors and suppliers on the project from which Contractor has required retainages.

- E. 5.1.3 The retainage held by Owner shall be included in and paid to the Contractor as part of the Final Payment of the Contract Price. The Owner shall pay to Contractor interest at the rate of two-thirds of one percent per month on the final payment due Contractor, interest to commence forty five (45) Days after the date which Owner receives Contractor's final approved application for payment and Work under the Contract has been completed and accepted and to run until the date when final payment is tendered to Contractor. The Contractor shall notify Owner in writing when the Contractor considers the Work complete and deliver to Owner its final application for payment and Owner shall, within fifteen (15) Days after receiving the written notice and the application for payment, either accept the Work or notify the Contractor of Work yet to be performed on the Contract. If Owner does not within the time allowed notify the Contractor of Work yet to be performed to fulfill contractual obligations, the interest provided by this subsection shall commence to run forty five (45) Days after the end of the 15-Day period.

- E.5.1.4 Owner will reduce the amount of the retainage if the Contractor notifies the controller of the Owner that the Contractor has deposited in an escrow account with a bank or trust company, in a manner authorized by the Owner, bonds and securities of equal value of a kind approved by the Owner and such bonds and securities have in fact been deposited.

- E.5.1.5 Contractor agrees that if Contractor elects to reserve a retainage from any progress payment due to any Subcontractor or supplier, such retainage shall not exceed five percent of the payment, and such retainage withheld from Subcontractors and suppliers shall be subject to the same terms and conditions stated in Subsection E.5 as apply to Owner's retainage from any progress payment due to Contractor.

E.6 FINAL PAYMENT

- E.6.1 Upon completion of all the Work under this Contract, the Contractor shall notify the Owner, in writing, that Contractor has completed Contractor's obligations under the Contract and shall prepare its application requesting final payment. Upon receipt of such notice and application for payment, the Owner will inspect the Work, and, if acceptable, submit to the Owner a recommendation as to acceptance of the completed Work and the final estimate of the amount due the Contractor. If the Work is not acceptable, Owner will notify Contractor within fifteen (15) Days of Contractor's request for Final Payment. Upon approval of this final application for payment by the Owner and compliance by the Contractor with provisions in Section K, and Contractor's satisfaction of other provisions of the Contract Documents as may be applicable, the Owner shall pay to the Contractor all monies due under the provisions of these Contract Documents.

- E.6.2 Neither Final Payment nor any remaining retained percentage shall become due until the Contractor submits to the Owner (1) a certificate evidencing that insurance required by the Contract

Documents to remain in force after Final Payment is currently in effect and will not be canceled or allowed to expire until at least thirty (30) Days' prior written notice has been given to the Owner, (2) a written statement that the Contractor knows of no substantial reason that the insurance will not be renewable to cover the period required by the Contract Documents, (3) consent of surety, if any, to Final Payment and (4), if required by the Owner, other data establishing payment or satisfaction of obligations, such as receipts, releases and waivers of liens, claims, security interests or encumbrances arising out of the Contract, to the extent and in such form as may be designated by the Owner. If a Subcontractor refuses to furnish a release or waiver required by the Owner, the Contractor may furnish a bond satisfactory to the Owner to indemnify the Owner against such lien. If such lien remains unsatisfied after payments are made, the Contractor shall refund to the Owner all money that the Owner may be compelled to pay in discharging such lien, including all costs and reasonable attorneys' fees.

- E.6.3 Acceptance of Final Payment by the Contractor, a Subcontractor or material supplier shall constitute a waiver of claims by that payee except those previously made in writing and identified by that payee as unsettled at the time of final application for payment.

- E.6.4 Contractor agrees to submit its final payment application within ninety (90) Days after Substantial Completion, unless written extension is granted by Owner. Contractor shall not delay Final Payment application for any reason, including without limitation nonpayment of Subcontractors, suppliers, manufacturers or others not a party to this Contract, or lack of resolution of a dispute with Owner or any other person of matters arising out of or relating to the Contract. If Contractor fails to submit its Final Payment application within ninety (90) Days after Substantial Completion, and Contractor has not obtained written extension by Owner, all requests or Claims for additional costs or an extension of Contract Time shall be waived.

SECTION F JOB SITE CONDITIONS

F.1 USE OF PREMISES

Contractor shall confine equipment, storage of materials and operation of Work to the limits indicated by Contract Documents, Applicable Laws, permits or directions of the Owner. Contractor shall follow the Owner's instructions regarding use of premises, if any.

F.2 PROTECTION OF WORKERS, PROPERTY AND THE PUBLIC

- F.2.1 Contractor shall maintain continuous and adequate protection of all of the Work from damage and shall protect the Owner, workers and property from injury or loss arising in connection with this Contract. Contractor shall remedy acceptably to the Owner any damage, injury, or loss, except such as may be directly due to errors in the Contract Documents or caused by authorized representatives or personnel of the Owner. Contractor shall adequately protect adjacent property as provided by law and the Contract Documents.

- F.2.2 Contractor shall take all necessary precautions for the safety of all personnel on the job site or otherwise engaged in the undertaking of the Work and shall comply with the Contract Documents, best practices and all applicable provisions of federal, state and municipal safety laws and building codes to prevent accidents or injury to persons on, about or adjacent to the premises where the Work is being performed. Contractor shall erect and properly maintain at all times, as required by the conditions and progress of the Work, all necessary safeguards for protection of workers and the public against any hazards created by construction. Contractor shall designate a responsible employee or associate on the Work site, whose duty shall be the

prevention of accidents. The name and position of the person designated shall be reported to the Owner. The Owner has no responsibility for Work site safety. Work site safety shall be the responsibility of the Contractor.

F.2.3 Contractor shall not enter upon private property without first obtaining permission from the property owner or its duly authorized representative. Contractor shall be responsible for the preservation of all public and private property along and adjacent to the Work contemplated under the Contract and shall use every precaution necessary to prevent damage thereto. In the event the Contractor damages any property, the Contractor shall at once notify the property owner and make, or arrange to make, full restitution. Contractor shall, immediately and in writing, report to the Owner, all pertinent facts relating to such property damage and the ultimate disposition of the claim for damage.

F.2.4 Contractor shall be responsible for protection of adjacent work areas including impacts brought about by activities, equipment, labor, utilities, vehicles and materials on the site.

F.2.5 Contractor shall at all times direct its activities in such a manner as to minimize adverse effects on the environment. Handling of all materials shall be conducted so no release will occur that may pollute or become hazardous.

F.2.6 In an emergency affecting the safety of life or limb or of the Work or of adjoining property, the Contractor, without special instruction or authorization from the Owner, shall act reasonably to prevent threatened loss or injury, and shall so act, without appeal, if instructed by the Owner. Any compensation claimed by the Contractor on account of emergency work shall be determined in accordance with section D.

F.3 CUTTING AND PATCHING

F.3.1 Contractor shall be responsible for coordinating all cutting, fitting, or patching of the Work to make its several parts come together properly and fit to receive or be received by work of other contractors or Subcontractors shown upon, or reasonably implied by, the Contract Documents.

F.3.2 Contractor shall be responsible for restoring all cut, fitted, or patched surfaces to an original condition; provided, however, that if a different condition is specified in the Contract Documents, then Contractor shall be responsible for restoring such surfaces to the condition specified in the Contract Documents.

F.4 CLEANING UP

From time to time as may be prudent or ordered by the Owner and, in any event, immediately after completion of the Work, the Contractor shall, at its own expense, clean up and remove all refuse and unused materials of any kind resulting from the Work. If Contractor fails to do so within twenty-four hours after notification by the Owner the work may be done by others and the cost charged to the Contractor and deducted from payment due the Contractor.

F.5 ENVIRONMENTAL CONTAMINATION

F.5.1. Contractor shall be held responsible for and shall indemnify, defend (with counsel of Owner's choice), and hold harmless Owner from and against any costs, expenses, damages, claims, and causes of action, (including attorney fees), or any of them, resulting from all spills, releases, discharges, leaks and disposal of environmental pollution, including storage, transportation, and handling during the performance of the Work or Contractor's obligations under the Contract which occur as a result of, or are contributed by, the negligence or actions of Contractor or its personnel, agents, or Subcontractors or any failure to perform in accordance with the Contract Documents

(except to the extent otherwise void under ORS 30.140). Nothing in this section F.5.1 shall limit Contractor's responsibility for obtaining insurance coverages required under Section G.3 of this Contract, and Contractor shall take no action that would void or impair such coverages.

F.5.1.1 Contractor agrees to promptly dispose of such spills, releases, discharge or leaks to the satisfaction of Owner and regulatory agencies having jurisdiction in a manner that complies with Applicable Laws. Cleanup shall be at no cost to the Owner and shall be performed by properly qualified and, if applicable, licensed personnel.

F.5.1.2 Contractor shall obtain the Owner's written consent prior to bringing onto the Work site any (i) environmental pollutants or (ii) hazardous substances or materials, as the same or reasonably similar terms are used in any Applicable Laws. Notwithstanding such written consent from the Owner, the Contractor, at all times, shall:

- (a) Properly handle, use and dispose of all environmental pollutants and hazardous substances or materials brought onto the Work site, in accordance with all Applicable Laws;
- (b) Be responsible for any and all spills, releases, discharges, or leaks of (or from) environmental pollutants or hazardous substances or materials which Contractor has brought onto the Work site; and
- (c) Promptly clean up and remediate, without cost to the Owner, such spills, releases, discharges, or leaks to the Owner's satisfaction and in compliance with all Applicable Laws.

F.5.2 Contractor shall report all reportable quantity releases, as such releases are defined in Applicable Laws, including but not limited to 40 CFR Part 302, Table 302.4 and in OAR 340-142-0050, to applicable federal, state, and local regulatory and emergency response agencies. Upon discovery, regardless of quantity, Contractor must telephonically report all releases to the Owner. A written follow-up report shall be submitted to Owner within 48 hours of the telephonic report. Such written report shall contain, as a minimum:

- (a) Description of items released (identity, quantity, manifest numbers, and any and all other documentation required by law.)
- (b) Whether amount of items released is EPA/DEQ reportable, and, if so, when reported.
- (c) Exact time and location of release, including a description of the area involved.
- (d) Containment procedures initiated.
- (e) Summary of communications about the release between Contractor and members of the press or State, local or federal officials other than Owner.
- (f) Description of cleanup procedures employed or to be employed at the site, including disposal location of spill residue.
- (g) Personal injuries, if any, resulting from, or aggravated by, the release.

F.6 ENVIRONMENTAL CLEAN-UP

F.6.1 Unless disposition of environmental pollution is specifically a part of this Contract, or was caused by the Contractor (reference

F.5 Environmental Contamination), Contractor shall immediately notify Owner of any hazardous substance(s) which Contractor discovers or encounters during performance of the Work required by this Contract. "Hazardous substance(s)" means any hazardous, toxic and radioactive materials and those substances defined as "hazardous substances," "hazardous materials," "hazardous wastes," "toxic substances," or other similar designations in any federal, state, or local law, regulation, or ordinance, including without limitation asbestos, polychlorinated biphenyl (PCB), or petroleum, and any substances, materials or wastes regulated by 40 CFR, Part 261 and defined as hazardous in 40 CFR S 261.3. In addition to notifying Owner of any hazardous substance(s) discovered or encountered, Contractor shall immediately cease working in any particular area of the project where a hazardous substance(s) has been discovered or encountered if continued work in such area would present a risk or danger to the health or well-being of Contractor's or any Subcontractor's work force, property or the environment.

F.6.2 Upon being notified by Contractor of the presence of hazardous substance(s) on the project site, Owner shall arrange for the proper disposition of such hazardous substance(s).

F.7 FORCE MAJEURE

A party to this Contract shall not be held responsible for delay or default due to Force Majeure acts, events or occurrences unless they could have been avoided by the exercise of reasonable care, prudence, foresight, and diligence by that party. The Owner may terminate this Contract upon written notice after determining that delay or default caused by Force Majeure acts, events or occurrences will reasonably prevent successful performance of the Contract.

SECTION G INDEMNITY, BONDING, AND INSURANCE

G.1 RESPONSIBILITY FOR DAMAGES / INDEMNITY

G.1.1 Contractor shall be responsible for all damage to property, injury to persons, and loss, expense, inconvenience, and delay that may be caused by, or result from, the carrying out of the Work to be done under this Contract, or from any act, omission or neglect of the Contractor, its Subcontractors, sub-subcontractors of any tier, suppliers, employees, guests, visitors, invitees and agents.

G.1.2 To the fullest extent permitted by law, Contractor shall indemnify, defend (with counsel approved by Owner) and hold harmless the Owner, Architect/Engineer, Architect/Engineer's consultants, and their respective officers, directors, agents, employees, partners, members, stockholders and affiliated companies (collectively "Indemnitees") from and against all liabilities, damages, losses, claims, expenses (including reasonable attorney fees), demands and actions of any nature whatsoever which arise out of, result from or are related to, (a) any damage, injury, loss, expense, inconvenience or delay described in this Section G.1., (b) any accident or occurrence which happens or is alleged to have happened in or about the project site or any place where the Work is being performed, or in the vicinity of either, at any time prior to the time the Work is fully completed in all respects, (c) any failure of the Contractor or its Subcontractors, sub-subcontractors of any tier, suppliers, employees or consultants to observe or perform any duty or obligation under the Contract Documents which is to be observed or performed by the Contractor, or any breach of any agreement, representation or warranty of the Contractor contained in the Contract Documents or in any subcontract, (d) the negligent acts or omissions of the Contractor, a Subcontractor, sub-subcontractor of any tier suppliers, a consultant or anyone directly or indirectly employed by them or any one of them or anyone for whose acts they may be liable, regardless of whether or not such claim, damage, loss or expense

is caused in part by a party indemnified hereunder (except to the extent otherwise void under ORS 30.140), and (e) any lien filed upon the project or bond claim in connection with the Work. Such obligation shall not be construed to negate, abridge, or reduce other rights or obligations of indemnity which would otherwise exist as to a party or person described in this Section G.1.2.

G.1.3 In claims against any person or entity indemnified under Section G.1.2 by an employee of the Contractor, a Subcontractor, anyone directly or indirectly employed by them or anyone for whose acts they may be liable, the indemnification obligation under Section G.1.2 shall not be limited by a limitation on amount or type of damages, compensation or benefits payable by or for the Contractor or a Subcontractor under workers' compensation acts, disability benefit acts or other employee benefit acts.

G.2 PERFORMANCE AND PAYMENT SECURITY; PUBLIC WORKS BOND

G.2.1 When the Contract Price is \$150,000 or more (or \$50,000 or more in the case of Contracts for highways, bridges and other transportation projects), the Contractor shall furnish and maintain in effect at all times during the Contract Period a performance bond in a sum equal to the Contract Price and a separate payment bond also in a sum equal to the Contract Price. Contractor shall furnish such bonds even if the Contract Price is less than the above thresholds if otherwise required by the Contract Documents.

G.2.2 Bond forms furnished by the Owner and notarized by awarded Contractor's surety company authorized to do business in Oregon are the only acceptable forms of performance and payment security, unless otherwise specified in the Contract Documents.

G.2.3 Before execution of the Contract the Contractor shall file with the Construction Contractors Board, and maintain in full force and effect, the separate public works bond required by ORS Chapter 279C, and OAR 839-025-0015, unless otherwise exempt under those provisions. The Contractor shall also include in every subcontract a provision requiring the Subcontractor to have a public works bond filed with the Construction Contractors Board before starting Work, unless otherwise exempt, and shall verify that the Subcontractor has filed a public works bond before permitting any Subcontractor to start Work.

G.3 INSURANCE

G.3.1 General Requirements. The required insurance amounts set forth below do not in any way limit the amount or scope of liability of Contractor under this Contract. The amounts listed indicate only the minimum amounts of insurance coverage Owner is willing to accept to help insure full performance of all terms and conditions of this Contract.

G.3.1.1 Primary Coverage: Insurance carried by Contractor under this Contract shall be the primary and non-contributory coverage. The coverages indicated are minimums unless otherwise specified in the Contract Documents.

G.3.1.2 Company Ratings. All policies of insurance must be written by companies having an A.M. Best rating of no less than "A-VII", or equivalent. Owner may, upon thirty (30) days written notice to Contractor, require Contractor to change any carrier whose rating drops below an "A-VII" rating. Eligible insurers include admitted insurers that have been issued a certificate of authority from the Oregon Department of Consumer and Business Services authorizing them to conduct an insurance business and issue policies of insurance in the state of Oregon, and certain non-admitted surplus lines insurers that satisfy the

requirements of applicable Oregon law and which are subject to approval the Owner.

G.3.1.3 Additional Insured: Each liability policy, except for Worker's Compensation, shall be endorsed to include Owner, its officers, trustees, employees and agents as additional insured but only with respect to the Contractor's activities to be performed under this Contract.

If Contractor cannot obtain an insurer to name the Owner as additional insured, Contractor shall obtain at Contractor's expense, and keep in effect during the term of this Contract, Owners and Contractors Protective Liability Insurance, naming the Owner as additional insured with minimum limits of \$2,000,000 per occurrence and \$2,000,000 aggregate. This policy must be kept in effect for 36 months following Final Completion. As evidence of coverage, Contractor shall furnish the actual policy to Owner prior to execution of the Contract.

G.3.1.4 Notice of Cancellation or Change: If the Contractor receives a non-renewal or cancellation notice from an insurance carrier affording coverage required herein, or receives notice that coverage no longer complies with the insurance requirements herein, Contractor agrees to notify Owner by fax within five (5) business days with a copy of the non-renewal or cancellation notice, or written specifics as to which coverage is no longer in compliance. When notified by Owner, the Contractor agrees to stop Work pursuant to this Contract, unless all required insurance remain in effect. Any failure to comply with the reporting provisions of this insurance, except for the potential exhaustion of aggregate limits, shall not affect the coverages provided to the Owner.

Owner shall have the right, but not the obligation, of prohibiting Contractor from entering the Work site until a new certificate(s) of insurance is provided to Owner evidencing the replacement coverage. The Contractor agrees Owner reserves the right to withhold payment to Contractor until evidence of reinstated or replacement coverage is provided to Owner.

G.3.2 Workers' Compensation: All employers, including Contractor, that employ subject workers who work under this Contract in the State of Oregon shall comply with ORS 656.017 and provide the required Workers' Compensation coverage, unless such employers are exempt under ORS 656.126. This shall include Employer's Liability Insurance with minimum limits of \$1,000,000 each accident; \$1,000,000 disease-each employee; and \$1,000,000 disease-policy limit. Contractors who perform the Work without the assistance or labor of any employee need not obtain such coverage if the Contractor certifies so in writing. Contractor shall ensure that each of its Subcontractors complies with these requirements. The Contractor shall require proof of such Workers' Compensation coverage by receiving and keeping on file a certificate of insurance from each Subcontractor or anyone else directly employed by either the Contractor or its Subcontractors.

G.3.3 Commercial General Liability: Contractor shall obtain, and keep in effect at Contractor's expense for the term of the Contract, Commercial General Liability Insurance covering bodily injury and property damage in the minimum amount of \$2,000,000 per occurrence and \$4,000,000 aggregate. This insurance shall include personal injury liability, products and completed operations, and contractual liability for the indemnities provided under this Contract (to the extent contractual liability coverage for the indemnity is available in the marketplace).

G.3.4. Automobile Liability: Contractor shall obtain, at Contractor's expense, and keep in effect during the term of this Contract, Automobile Liability Insurance with "symbol 1" coverage (owned, hired, and non-owned vehicles). The coverage may

be written in combination with the Commercial General Liability Insurance. Contractor shall provide proof of insurance showing minimum limits of \$2,000,000 combined single limit. Contractor and its Subcontractors shall be responsible for ensuring that all non-owned vehicles maintain adequate Automobile Liability insurance while on site. If the scope of services in this Contract requires the transportation of any hazardous material or regulated substances, the policy shall include a CA 9948 endorsement or its equivalent and MCS-90 to provide coverage for claims resulting in bodily injury, property damage or cleanup costs associated with a pollution condition from transported cargo.

G.3.5 Owner may adjust the insurance amounts required in Section G.3.3 and G.3.4 through the issuance of Supplemental General Conditions.

G.3.6 Pollution Liability: When required by Supplemental General Conditions, Contractor shall obtain, at Contractor's expense, and keep in effect during the term of this Contract, Pollution liability Insurance in minimum amounts of \$3,000,000 per occurrence and \$3,000,000 aggregate, naming Owner as additional insured as noted in the Additional Insured section.

G.3.7 Certificate(s) of Insurance: As evidence of the insurance coverage required by this Contract, the Contractor shall furnish certificate(s) of insurance to the Owner prior to execution of the Contract. The certificate(s) will specify all of the parties who are additional insureds for this contract, and the applicable endorsements will be attached. Additional insured endorsements must include completed operations without restriction to contractual requirements.

G.3.8 Subcontractors. Subject to and following the written approval of the Owner as outlined in B.11.3 as related to Subcontracts and Assignment, the Contractor shall require Subcontractors to have insurance as outlined in section G.3.1 through G.3.4; however, the policy limits may be reduced, but no case shall the policy limits be less than \$1,000,000.

SECTION H SCHEDULE OF WORK

H.1 CONTRACT PERIOD

H.1.1 Time is of the essence. The Contractor shall at all times carry on the Work diligently, without delay and punctually fulfill all requirements herein. If required by the Contract Documents, Contractor shall commence Work on the site within fifteen (15) Days of Notice to Proceed, unless directed otherwise.

H.1.2 Unless specifically extended by Supplement Amendment, all Work shall be complete by the date contained in the Contract Documents. The Owner shall have the right to accelerate the completion date of the Work, which may require the use of overtime. Such accelerated Work schedule shall be an acceleration in performance of Work under Section D.1.2 (f) and shall be subject to the provisions of Section D.1.

H.1.3 The Owner shall not waive any rights under the Contract by permitting the Contractor to continue or complete in whole or in part the Work after the date described in Section H.1.2 above.

H.2 SCHEDULE

H.2.1 Contractor shall provide, by or before the pre-construction conference, the initial as-planned Construction Schedule for review and acceptance by the Owner. The submitted Construction Schedule must illustrate Work by project components, labor trades, and long lead items broken down by building and/or floor where applicable. If Owner shall so elect, Contractor shall provide the schedule in CPM format showing

the graphical network of planned activities, including i) a reasonably detailed list of all activities required to complete the Work; ii) the time and duration that each activity will take to completion; and iii) the dependencies between the activities. Construction Schedules lacking adequate detail, or unreasonably detailed, will be rejected. The Construction Schedule shall include the following: Notice to Proceed or the date the Work commences, if no Notice to Proceed is issued by Owner, Substantial Completion, and Final Completion. Schedules shall be updated monthly, unless otherwise required by the Contract Documents, and submitted with the monthly application for payment. Acceptance of the Construction Schedule by the Owner does not constitute agreement by the Owner as to the Contractor's sequencing, means, methods, or durations. Any positive difference between the Contractor's scheduled completion and the Contract completion date is float owned by the Owner. Owner reserves the right to negotiate the float if it is deemed to be in Owner's best interest to do so. In no case shall the Contractor make a claim for delays if the Work is completed within the Contract Time but after Contractor's scheduled completion.

H.3 PARTIAL OCCUPANCY OR USE

H.3.1 The Owner may occupy or use any completed or partially completed portion of the Work at any stage, provided such occupancy or use is consented to by public authorities having jurisdiction over the Work. Such partial occupancy or use may commence whether or not the portion is substantially complete, provided the Owner and Contractor have reasonably accepted in writing the responsibilities assigned to each of them for payments, retainage, if any, security, insurance or self-insurance, maintenance, heat, utilities, and damage to the Work, and have agreed in writing concerning the period for correction of the Work and commencement of warranties required by the Contract Documents with respect to such portion of the Work. Approval by the Contractor to partial occupancy or use shall not be unreasonably withheld. Immediately prior to such partial occupancy or use, the Owner and Contractor shall jointly inspect the area to be occupied or portion of the Work to be used in order to determine and record the condition of the Work. Partial occupancy or use of a portion or portions of the Work shall not constitute acceptance of Work not complying with the requirements of the Contract Documents.

SECTION I CORRECTION OF WORK

I.1 CORRECTION OF WORK BEFORE FINAL PAYMENT

The Contractor warrants to the Owner that materials and equipment furnished under the Contract will be of good quality and new unless otherwise required or permitted by the Contract Documents, that the Work will be free from defects, and that the Work will conform to the requirements of the Contract Documents. Work failing to conform to these requirements shall be deemed defective. Contractor shall promptly remove from the premises and replace all defective materials and equipment as determined by the Owner, whether incorporated in the Work or not. Removal and replacement shall be without loss or expense to the Owner, and Contractor shall bear the cost of repairing all Work destroyed or damaged by such removal or replacement. Contractor shall be allowed a period of no longer than thirty (30) Days after Substantial Completion for completion of defective (Punch List) work. At the end of the thirty-day period, or earlier if requested by the Contractor, Owner shall arrange for inspection of the Work by the Architect/Engineer. Should the work not be complete, and all corrections made, the costs for all subsequent re-inspections shall be borne by the Contractor. If Contractor fails to complete the Punch List work within the thirty (30) Day period, Owner may perform such work and Contractor shall reimburse Owner all costs of the same within ten (10) Days after demand without affecting Contractor's obligations.

I.2 WARRANTY WORK

I.2.1 Neither the final certificate of payment nor any provision of the Contract Documents shall relieve the Contractor from responsibility for defective Work and, unless a longer period is specified, Contractor shall correct all defects that appear in the Work within a period of one year from the date of issuance of the written notice of Substantial Completion by the Owner except for latent defects which will be remedied by the Contractor at any time they become apparent. The Owner shall give Contractor notice of defects with reasonable promptness. The Contractor shall perform the warranty Work by correcting defects within twenty-four (24) hours of notification by Owner, unless otherwise specified in the Contract Documents. Should the Contractor fail to respond within the specified response time, the Owner may, at its option, complete the necessary repairs using another contractor or its own forces. If Owner completes the repairs using Owner's own forces, Contractor shall pay Owner at the rate of one and one-half (1½) times the standard hourly rate of Owner's forces, plus related overhead and any direct non-salary costs. If Owner completes the repairs using another contractor, Contractor shall pay Owner the amount of Owner's direct costs billed by the other contractor for the work, plus the direct salary costs and related overhead and direct non-salary expenses of Owner's forces who are required to monitor that contractor's work. Work performed by Owner using Owner's own forces or those of another contractor shall not affect the Contractor's contractual duties under these provisions, including warranty provisions. In the event of warranty work consisting of emergency repairs, Owner may perform such work and Contractor shall reimburse Owner all costs of the same within ten (10) Days after demand, without affecting Contractor's obligations.

I.2.2 Nothing in this Section I.2 provision shall negate guarantees or warranties for periods longer than one year including without limitation such guarantees or warranties required by other sections of the Contract Documents for specific installations, materials, processes, equipment or fixtures.

I.2.3 In addition to Contractor's warranty, manufacturer's warranties shall pass to the Owner and shall not take effect until such portion of the Work covered by the applicable warranty has been accepted in writing by the Owner.

I.2.4 The one-year period for correction of Work shall be extended with respect to portions of Work performed after Substantial Completion by the period of time between Substantial Completion and the actual performance of the Work, and shall be extended by corrective Work performed by the Contractor pursuant to this Section, as to the Work corrected. The Contractor shall remove from the site portions of the Work which are not in accordance with the requirements of the Contract Documents and are neither corrected by the Contractor nor accepted by the Owner.

I.2.5 Nothing contained in this Section I.2 shall be construed to establish a period of limitation with respect to other obligations which the Contractor might have under the Contract Documents. Establishment of the period for correction of Work as described in this Section I.2 relates only to the specific obligation of the Contractor to correct the Work, and has no relationship to the time within which the obligation to comply with the Contract Documents may be sought to be enforced, nor to the time within which proceedings may be commenced to establish the Contractor's liability with respect to the Contractor's obligations other than specifically to correct the Work.

I.2.6 If the Owner prefers to accept Work which is not in accordance with the requirements of the Contract Documents, the Owner may do so instead of requiring its removal and correction, in which case the Contract Price will be reduced as appropriate and

equitable. Such adjustment shall be effected whether or not final payment has been made.

SECTION J SUSPENSION AND/OR TERMINATION OF THE WORK

J.1 OWNER'S RIGHT TO SUSPEND THE WORK

J.1.1 The Owner has the authority to suspend portions or all of the Work due to the following causes:

- (a) Failure of the Contractor to correct unsafe conditions;
- (b) Failure of the Contractor to carry out any provision of the Contract;
- (c) Failure of the Contractor to carry out orders;
- (d) Conditions, in the opinion of the Owner, which are unsuitable for performing the Work;
- (e) Time required to investigate differing site conditions;
- (f) Any reason considered to be in the public interest.

J.1.2 The Owner shall notify Contractor and the Contractor's Surety in writing of the effective date and time of the suspension, and Owner shall notify Contractor and Contractor's surety in writing to resume Work.

J.2 CONTRACTOR'S RESPONSIBILITIES

J.2.1 During the period of the suspension, Contractor is responsible to continue maintenance at the project just as if the Work were in progress. This includes, but is not limited to, protection of completed Work, maintenance of access, protection of stored materials, temporary facilities, and clean-up.

J.2.2 When the Work is recommenced after the suspension, the Contractor shall replace or renew any Work damaged during the suspension, remove any materials or facilities used as part of temporary maintenance, and complete the project in every respect as though its prosecution had been continuous and without suspension.

J.3 COMPENSATION FOR SUSPENSION

J.3.1 Depending on the reason for suspension of the Work, the Contractor or the Owner may be due compensation by the other party. If the suspension was required due to acts or omissions of Contractor, the Owner may assess the Contractor actual costs of the suspension in terms of administration, remedial work by the Owner's forces or another contractor to correct the problem associated with the suspension, rent of temporary facilities, and other actual costs related to the suspension. If the suspension was caused by acts or omissions of the Owner, the Contractor may be due compensation which shall be defined using Section D, Changes in Work. If the suspension was required through no fault of the Contractor or the Owner, neither party shall owe the other for the impact.

J.4 OWNER'S RIGHT TO TERMINATE CONTRACT

J.4.1 The Owner may, without prejudice to any other right or remedy, and after giving Contractor seven (7) Days' written notice and an opportunity to cure, terminate the Contract in whole or in part under the following conditions:

- (a) If Contractor should, voluntarily or involuntarily, seek protection under the United States Bankruptcy Code and Contractor as debtor-in-possession or the Trustee for the

estate fails to assume the Contract within a reasonable time;

- (b) If Contractor should make a general assignment for the benefit of Contractor's creditors;
- (c) If a receiver should be appointed on account of Contractor's insolvency;
- (d) If Contractor should repeatedly refuse or fail to supply an adequate number of skilled workers or proper materials to carry on the Work as required by the Contract Documents, or otherwise fail to perform the Work in a timely manner;
- (e) If Contractor should repeatedly fail to make prompt payment to Subcontractors or for material or labor, or should disregard laws, ordinances or the instructions of the Owner; or
- (f) If Contractor is otherwise in breach of any part of the Contract.
- (g) If Contractor is in violation of Applicable Laws, either in the conduct of its business or in its performance of the Work.

J.4.2 At any time that any of the above occurs, Owner may exercise all rights and remedies available to Owner at law or in equity, and, in addition, Owner may take possession of the premises and of all materials and appliances and finish the Work by whatever method it may deem expedient. In such case, the Contractor shall not be entitled to receive further payment until the Work is completed. If the Owner's cost of finishing the Work exceeds the unpaid balance of the Contract Price, Contractor shall pay the difference to the Owner.

J.5 TERMINATION FOR CONVENIENCE

J.5.1 Owner may terminate the Contract in whole or in part whenever Owner determines that termination of the Contract is in the best interest of Owner or the public.

J.5.2 The Owner shall provide the Contractor with seven (7) Days prior written notice of a termination for Owner's or for public convenience. After such notice, the Contractor shall provide the Owner with immediate and peaceful possession of the premises and materials located on and off the premises for which the Contractor received progress payment under Section E. Compensation for Work terminated by the Owner under this provision will be according to Section E. In no circumstance shall Contractor be entitled to lost profits for Work not performed due to termination.

J.6 ACTION UPON TERMINATION

J.6.1 Upon receiving a notice of termination, and except as directed otherwise by the Owner, Contractor shall immediately cease placing further subcontracts or orders for materials, services, or facilities. In addition, Contractor shall terminate all subcontracts or orders to the extent they relate to the Work terminated and, with the prior written approval of the Owner, settle all outstanding liabilities and termination settlement proposals arising from the termination of subcontracts and orders.

J.6.2 As directed by the Owner, Contractor shall, upon termination, transfer title and deliver to the Owner all Record Documents, information, and other property that, if the Contract had been completed, would have been required to be furnished to the Owner.

J.6.3 Upon Owner's notice of termination pursuant to either Section J.4 or J.5, if Owner shall so elect, Contractor shall assign the

Owner such subcontracts and orders as Owner shall specify. In the event Owner elects to take assignment of any such subcontract or order, Contractor shall take such action and shall execute such documents as Owner shall reasonably require for the effectiveness of such assignment and Contractor shall ensure that no contractual arrangement between it and its subcontractors or suppliers of any tier or sub-tier shall prevent such assignment.

SECTION K CONTRACT CLOSE OUT

K.1 RECORD DOCUMENTS

As a condition of final payment (refer also to section E.6), Contractor shall comply with the following: Contractor shall provide Record Documents for the entire project to Owner. Record Documents shall depict the project as constructed and shall reflect each and every change, modification, and deletion made during the construction. Record Documents are part of the Work and shall be provided prior to the Owner's issuance of final payment. Record Documents include all modifications to the Contract Documents unless otherwise directed, and accurate MWESB Reports.

K.2 OPERATION AND MAINTENANCE MANUALS

As part of the Work, Contractor shall submit two completed operation and maintenance manuals ("O & M Manuals") for review by the Owner prior to submission of any pay request for more than 75% of the Work. Owner's receipt of the O & M Manuals shall be a condition precedent to any payment thereafter due. The O & M Manuals shall contain a complete set of all Submittals, all product data as required by the specifications, training information, telephone list and contact information for all consultants, manufacturers, installer and suppliers, manufacturer's printed data, record and shop drawings, schematic diagrams of systems, appropriate equipment indices, warranties and bonds. The Owner shall review and return one O & M Manual for any modifications or adjustments required. Prior to submission of its final pay request, Contractor shall deliver two (2) complete and approved sets of O & M Manuals in paper form and one (1) complete and approved set in electronic form to the Owner and Owner's receipt of the O & M Manuals shall be a condition precedent to Owner's obligation to make final payment.

K.3 COMPLETION NOTICES

K.3.1 Contractor shall provide Owner written notice of both Substantial and Final Completion. The certificate of Substantial Completion shall state the date of Substantial Completion, the responsibilities of the Owner and Contractor for security, maintenance, heat, utilities, damage to the Work and insurance, and the time within which the Contractor shall finish all items on the Punch List accompanying the Certificate. Both completion notices must be signed by the Contractor and the Owner to be valid. The Owner shall provide the final signature on the notices. The notices shall take effect on the date they are signed by the Owner.

K.3.2 Substantial Completion of a facility with operating systems (e.g., mechanical, electrical, HVAC) shall be that degree of completion that has provided a minimum of thirty (30) continuous Days of successful, trouble-free operation, which period shall begin after all performance and acceptance testing has been successfully demonstrated to the Owner. All equipment contained in the Work, plus all other components necessary to enable the Owner to operate the facility in the manner that was intended, shall be complete on the Substantial Completion date. The Contractor may request that a Punch List be prepared by the Owner with submission of the request for the Substantial Completion notice.

K.4 TRAINING

As part of the Work, and prior to submission of the final application for payment, the Contractor shall schedule with the Owner training sessions for all equipment and systems as required by the Contract Documents. Contractor shall schedule training sessions at least two weeks in advance of the date of training to allow Owner to provide its personnel with adequate notice. The O & M Manual shall be used as a basis for training. In addition to any off-site training required by the Contract Documents, training shall include a formal session conducted at the Work site after the equipment and/or system is completely installed and operational in its normal operating environment.

K.5 EXTRA MATERIALS

As part of the Work, Contractor shall provide spare parts, extra maintenance materials, and other materials or products in the quantities specified in the Contract Documents prior to final payment. Delivery point for extra materials shall be designated by the Owner.

K.6 ENVIRONMENTAL CLEAN-UP

As part of the Final Completion notice, or as a separate written notice submitted with or before the notice of Final Completion, the Contractor shall notify the Owner that all environmental and pollution clean-up, remediation and closure have been completed in accordance with all Applicable Laws and pursuant to the authority of all agencies having jurisdiction, and Contractor shall provide Owner with any and all documentation related to the same, including but not limited to directives, orders, letters, certificates and permits related to or arising from such environmental pollution. The notice shall reaffirm the indemnification given under Section F.5.1 above. Contractor's completion of its obligations under this Section K.6 and Owner's receipt of documents evidencing such completion shall be a condition precedent to Owner's obligation to make final payment.

K.7 CERTIFICATE OF OCCUPANCY

Owner's receipt of an unconditioned certificate of occupancy from the appropriate state and/or local building officials shall be a condition precedent to Owner's obligation to make final payment, except to the extent failure to obtain an unconditional certificate of occupancy is due to the sole fault or neglect of Owner.

K.8 OTHER CONTRACTOR RESPONSIBILITIES

The Contractor shall be responsible for returning to the Owner all property of Owner issued to Contractor during construction such as keys, security passes, site admittance badges, and all other pertinent items. Upon notice from Owner, Contractor shall be responsible for notifying the appropriate utility companies to transfer utility charges from the Contractor to the Owner. The utility transfer date shall not be before Substantial Completion and may not be until Final Completion, if the Owner does not take beneficial use of the facility and the Contractor's forces continue with the Work.

K.9 SURVIVAL

All warranty and indemnification provisions of this Contract, and all of Contractor's other obligations under this Contract that are not fully performed by the time of Final Completion or termination, shall survive Final Completion or any termination of the Contract.

Exhibit B
Sample Purchase Order

SAMPLE



Oregon State University

Purchase Order		
Purchase Order Date	PO/Reference No.	Revision No.
		1
Contact Information		
Shopper:		
Shopper Phone:		
Shopper Email:		

Supplier Information	Delivery Information
	Delivery Address
Billing Information	Billing Address

Line Item Details: **Total lines ordered 1**

Line No.	Product Description	Catalog No.	Size / Packaging	Unit Price	Quantity	Ext. Price
1 of 1	Flooring Install			USD	1 EA	USD
	<p>In accordance with the quote attached hereto and incorporated by this reference as Exhibit Number.</p> <p>A detailed list of labor, materials and pricing is listed in Exhibit Number.</p> <p>Location:</p> <p>Provide all materials, equipment, labor, transportation, services, and incidentals necessary to successfully complete the work described above at the location listed above.</p> <p>Coordinate delivery/work to be performed with OSU Person at phone number and/or email</p>					

Invoices and Certified Payroll should **ONLY** be sent to the contact and address under "Billing Address" listed above. Billing and payment questions should also **ONLY** be directed to the contact and email address under "Billing Address" listed above.

These services are subject to the Terms and Conditions of the Master Contract for Construction Related Services for Floor Coverings Oregon State University Contract Number XXXXXXX .

This is an Oregon Bureau of Labor & Industries (BOLI) Prevailing Wage Rates (PWR) project, see Attachment A, PWR.

Subtotal	
Shipping	0.00
Handling	0.00
Total	

Requested Delivery Date	Quote Number	Ship Via	F.O.B.
		Best Carrier-Best Way	Destination, Freight Prepaid and Allowed

Terms and Conditions

Header	15	Payment Terms	Net 30
	4	Acceptance	Agreement by Supplier to furnish the materials, goods or services on receipt of this order, commencement of performance, or acceptance of any payment, whichever occurs first, shall constitute Supplier's unqualified acceptance of this purchase order subject to the terms and conditions referenced herein. These terms and conditions, together with any referenced exhibits and attachments, constitute the entire agreement between the parties with respect to the subject matter of this purchase order and supersede any prior or contemporaneous written or oral agreements pertaining thereto. To the extent there are any conflicts between Supplier's terms and conditions, exhibits and attachments, and OSU's terms and conditions, exhibits and attachments, OSU's shall take precedence.
	5	Standard Terms and Conditions Link	Applicable terms and conditions may be viewed and downloaded from the Procurement, Contracts and Materials Management (PCMM) website at - https://fa.oregonstate.edu/pacs/suppliers . If you are unable to download the applicable terms and conditions, please contact PCMM at 541-737-4261 and a copy will be provided.

Approval Signature

Approval Signature

**CONTRACTOR QUOTE
COMPANY ABC**

Flooring

SCOPE OF WORK
Brand X Flooring.

BID PRICE **\$ 0.00**

SAMPLE

ATTACHMENT A PREVAILING WAGE RATES (PWR)

In compliance with Oregon Prevailing Wage Law, the following is incorporated into this Purchase Order Contract (Purchase Order):

The Contractor and all subcontractors shall comply with the provisions of Oregon Revised Statutes (ORS) 279C.800 through 279C.870, relative to PWR as outlined in Sections C.1 and C.2 of the Oregon State University (OSU) General Conditions for Purchase Order Construction Contracts (Terms and Conditions). This Purchase Order is subject to the following Oregon State Bureau of Labor and Industries (BOLI) PWR requirements, which are incorporated herein by reference:

- January 5, 2025 PWR Apprenticeship Rates
- January 5, 2025 PWR for Public Works Contracts in Oregon
- October 5, 2024 Definitions of Covered Occupations for Public Works Contracts in Oregon

These BOLI PWR are available on line at:

<https://www.oregon.gov/boli/employers/Pages/prevailing-wage-rates.aspx>

SAMPLE

**AMENDMENT TO MASTER CONTRACT FOR FOREST ROAD INFRASTRUCTURE
OREGON STATE UNIVERSITY
AMENDMENT NO.:
CONTRACT NUMBER XXXX-XXXXXX**

This Amendment dated _____ (the Amendment) is entered into between:

Contractor:

and Owner: Oregon State University
Construction Contracts Administration
644 Southwest 13th Street
Corvallis, Oregon 97333

(collectively, the Parties) pursuant to the Master Contract for Construction Related Services for Forest Road Infrastructure between the Parties (the Contract). Capitalized terms have the meaning defined in the General Conditions unless otherwise defined in the Contract or herein.

1. DESCRIPTION OF THE PROJECT. The project to which this Amendment pertains is described as follows: _____ (the Project).

2. WORK TO BE PERFORMED. Contractor shall perform the following work on the Project: _____ (the Work). Contractor will perform the Work according to the terms and conditions of this Amendment and the Contract Documents, which are incorporated herein by this reference. Work is further described in the Contractor proposal, dated _____, attached hereto and incorporated herein by this reference as Exhibit 1.

3. SCHEDULE. Contractor shall perform the Work according to the following schedule: _____ (the Schedule).

4. COMPENSATION. Owner shall compensate Contractor for Work on a time and materials basis subject to a maximum not-to-exceed price of \$ _____; in accordance with the requirements of the General Conditions. Refer to the Contract for Contractor's listing of wage rates. Material unit costs and approved markup for overhead for the Work is attached to this Amendment, included in Exhibit 1.

The cost of the Work under this Amendment, even if this Amendment is later modified to include additional work, must not exceed \$5,000,000.00.

5. AMENDMENT TERM. This Amendment is effective on the date it has been signed by every Party hereto and all approvals required by applicable law have been obtained (the Amendment Effective Date). No payment shall be made prior to the Amendment Effective Date. Contractor shall perform its Amendment obligations in accordance with this Amendment and the Contract, unless this Amendment is earlier terminated or suspended.

Contractor hereby agrees that the Work set forth in this Amendment may continue beyond the Term of the Contract and will be performed through final completion of Contractor's Work, including completion of all warranty work. The Parties expressly agree that they may execute a Modification and extend the date which Contractor's Work may be completed, which may include a date beyond the Term of the Contract.

Termination or suspension does not extinguish or prejudice Owner's right to enforce this Amendment with respect to any breach by the Contractor that has not been cured.

6. PERFORMANCE AND PAYMENT BONDS. The performance and payment bond requirements for this Project are as follows (check one of the following):

As a condition precedent to the effectiveness of this Supplement and to Owner's obligation to make payment for the Work, Contractor shall provide the Owner with a performance bond and a separate payment bond in a sum equal to the Contract Price stated in Section 4 of this Amendment.

This Project has a Contract price of \$150,000 or less, and Owner has determined that performance and payment bonds will not be required for this Project.

7. MINIMUM WAGE RATES.

Prevailing Wage Rates requirements apply to this Work. Contractor and all subcontractors shall comply with the provisions of ORS 279C.800 through 279C.870, relative to Prevailing Wage Rates and the required public works bond, as outlined in Sections C.1, C.2 and G.2.3 of the General Conditions. The Bureau of Labor and Industries (BOLI) wage rates and requirements set forth in the following BOLI booklet (and any listed amendments to that booklet), which are incorporated herein by reference, apply to the Work authorized under this Amendment:

PREVAILING WAGE RATES for Public Works Contracts in Oregon, January 5, 2025, which can be downloaded [here](#).

The Work will primarily take place in Benton County, Oregon, but could occur in other counties within Oregon.

8. INSURANCE REQUIREMENTS.

Contractor shall comply with and obtain the insurance coverage amounts stated in the General Conditions.

The Owner has determined that the Contractor shall obtain insurance in the amount described in the Supplemental General Conditions, attached hereto.

9. OTHER TERMS. Except as specifically modified by this Amendment, all terms of the Contract remain unchanged.

10. MODIFICATIONS. Any change to the terms and conditions of this Amendment require a fully executed written Modification.

11. EXECUTION AND COUNTERPARTS. This Amendment may be executed in several counterparts, each of which shall be an original, all of which shall constitute but one and the same instrument.

Contractor hereby confirms and certifies that the representations, warranties, and certifications contained in the Contract remain true and correct as of the Amendment Effective Date.

IN WITNESS HEREOF, the Parties have duly executed this Amendment as of the dates indicated below.

_____, Contractor

Oregon State University, Owner

By: _____

By: _____

Michael J. Green

Title: _____

Vice President for Finance and Administration

Date: _____

Date: _____

SAMPLE

OSU College Forests in Oregon

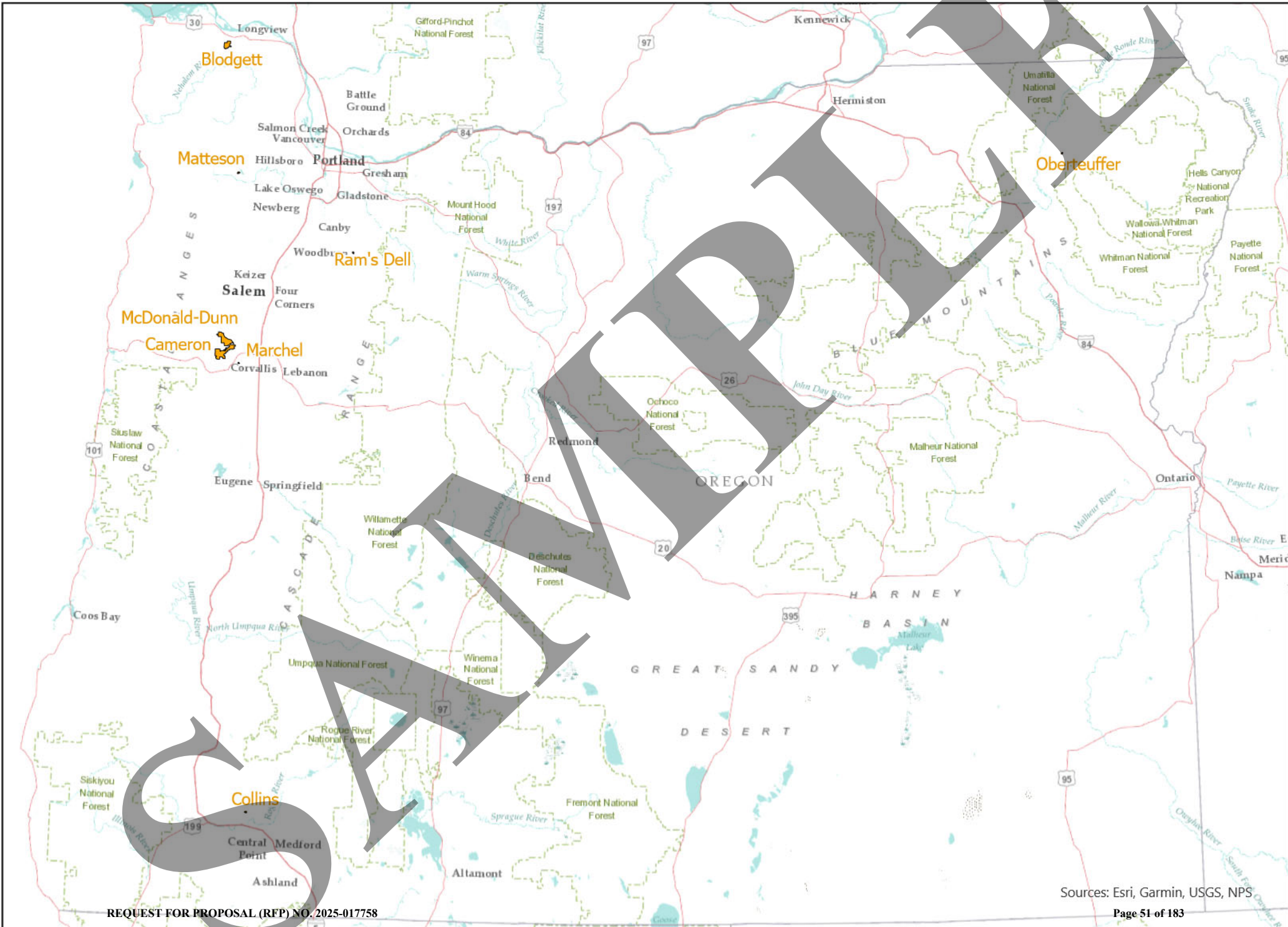

OSU Blodgett Forest
Columbia County, OR



Legend:

- Roads
- Blodgett Forest Tract
- Gates

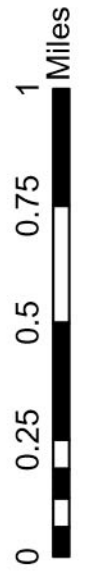
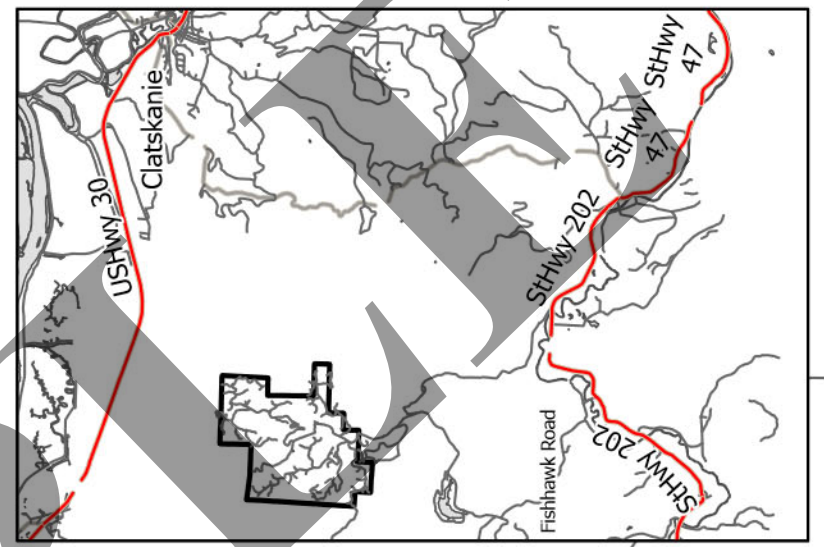
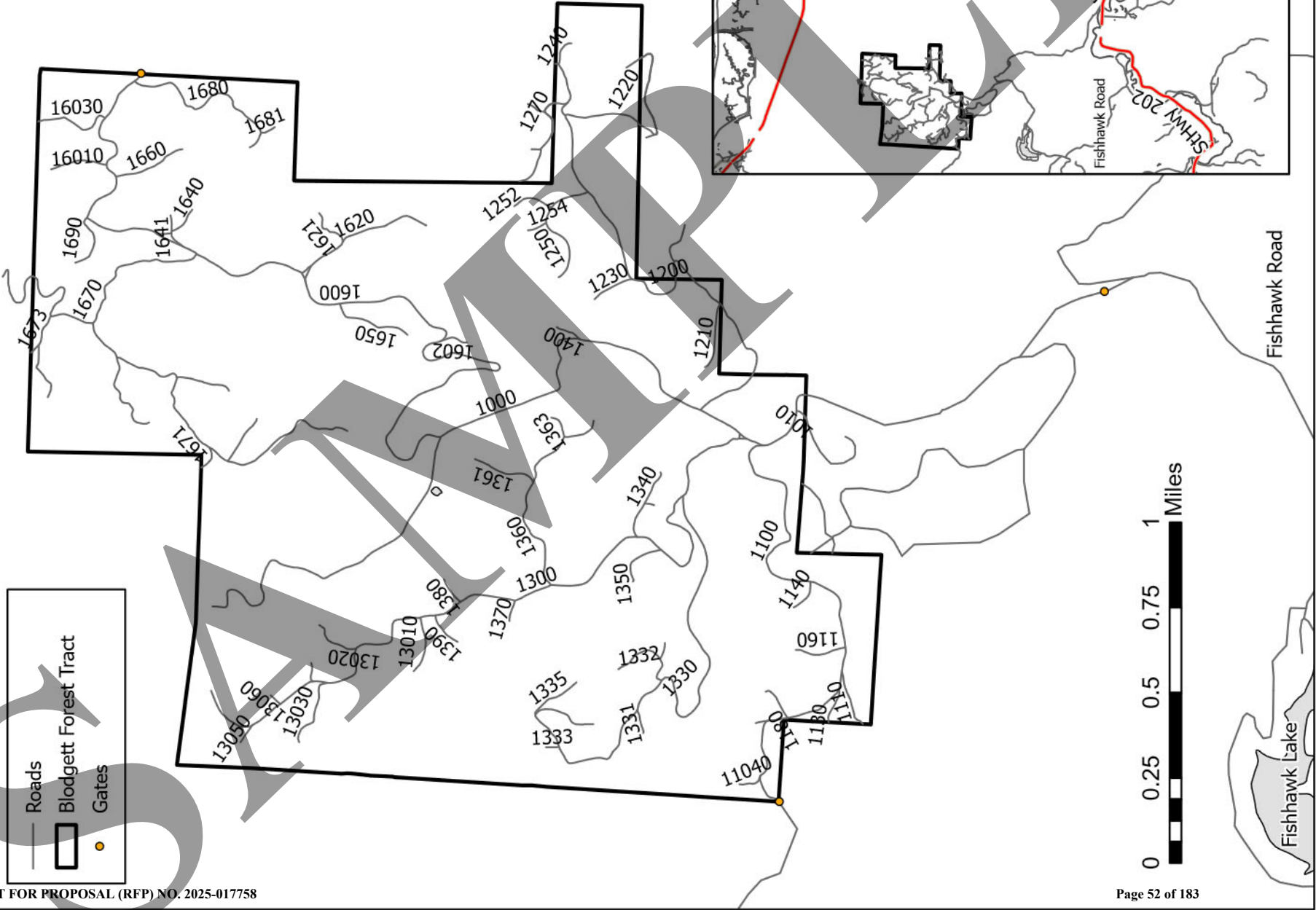

OSU Cameron Forest
Benton County, OR

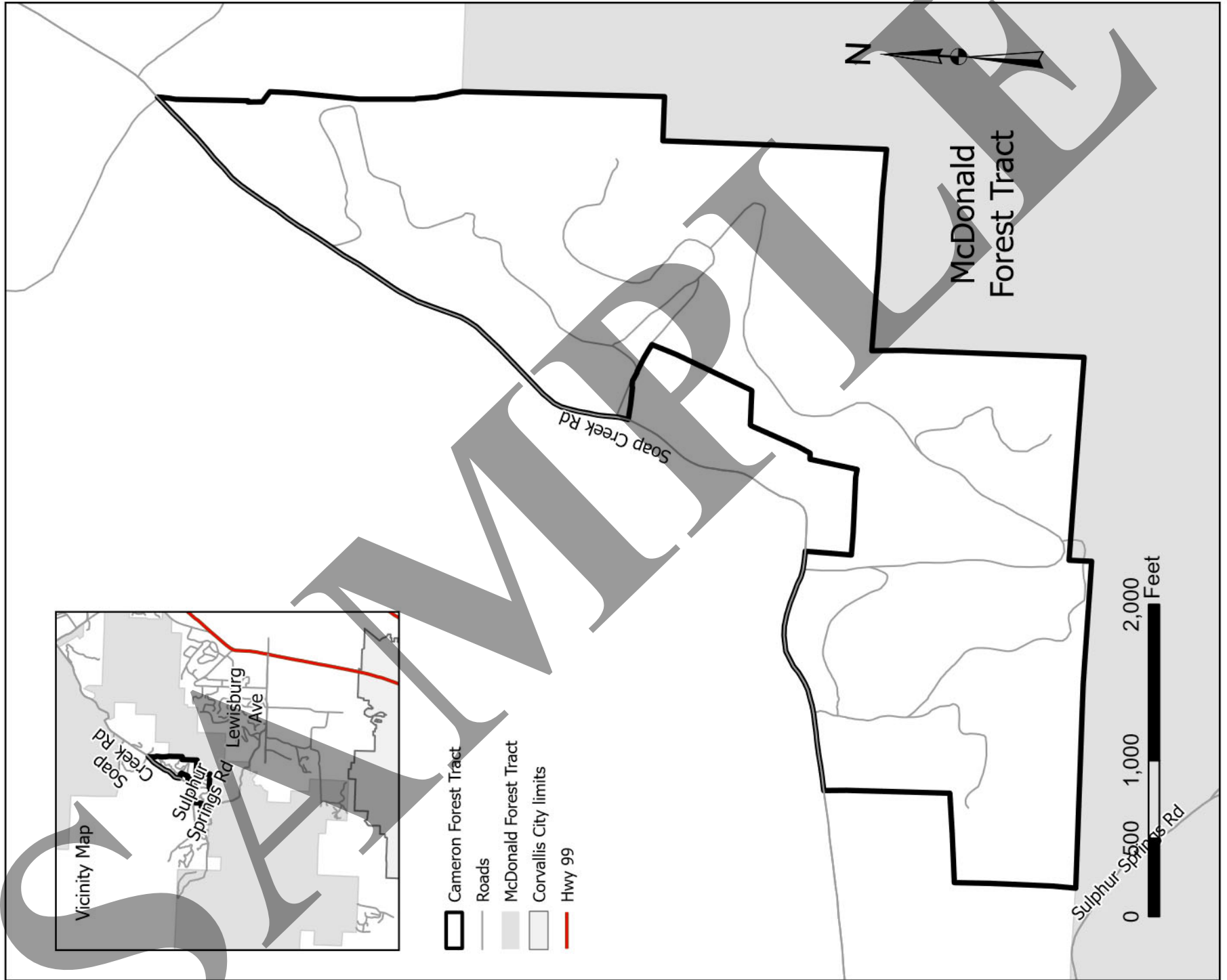

OSU Collins Forest
Jackson County, OR

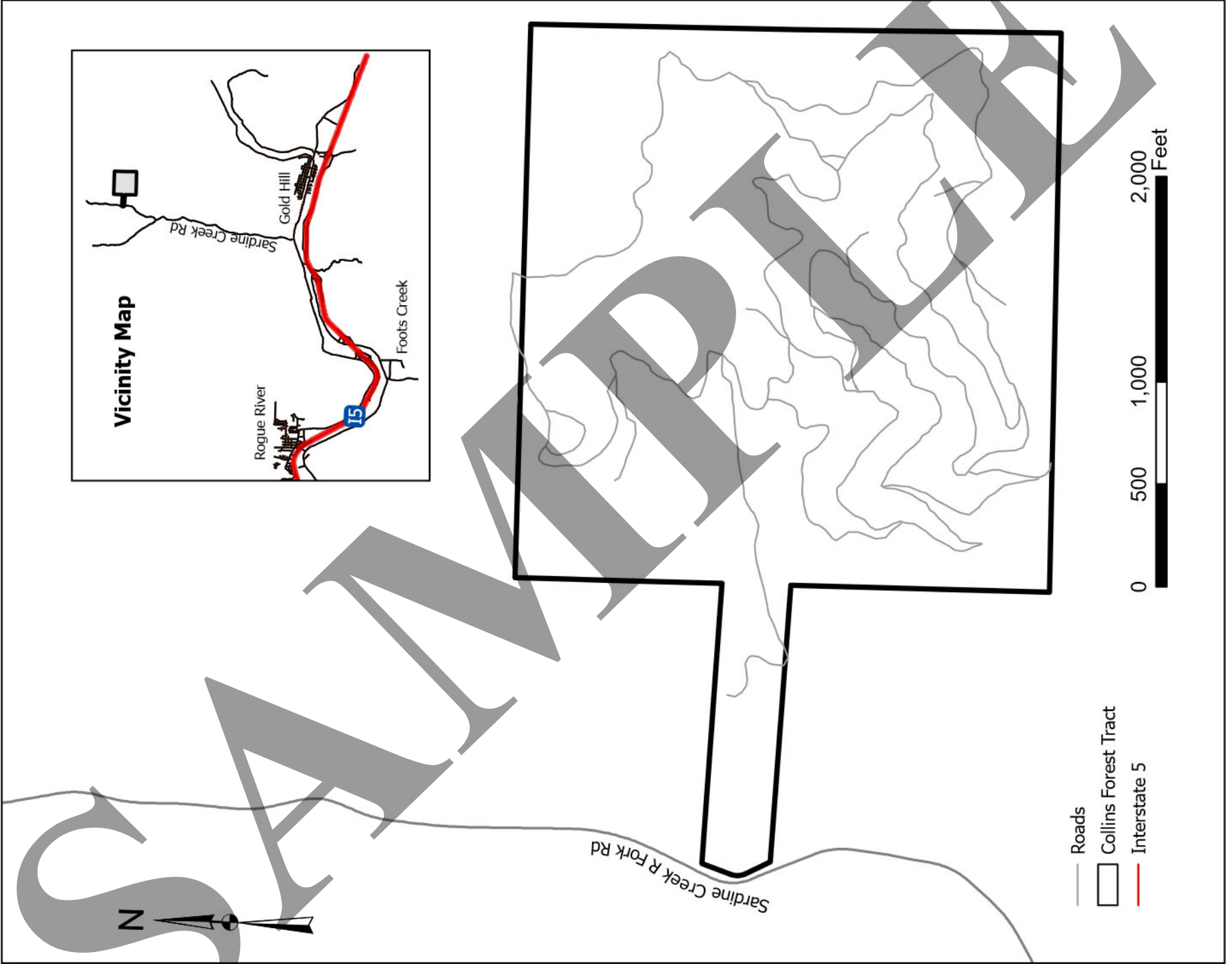

OSU Marchel Forest Benton County, OR

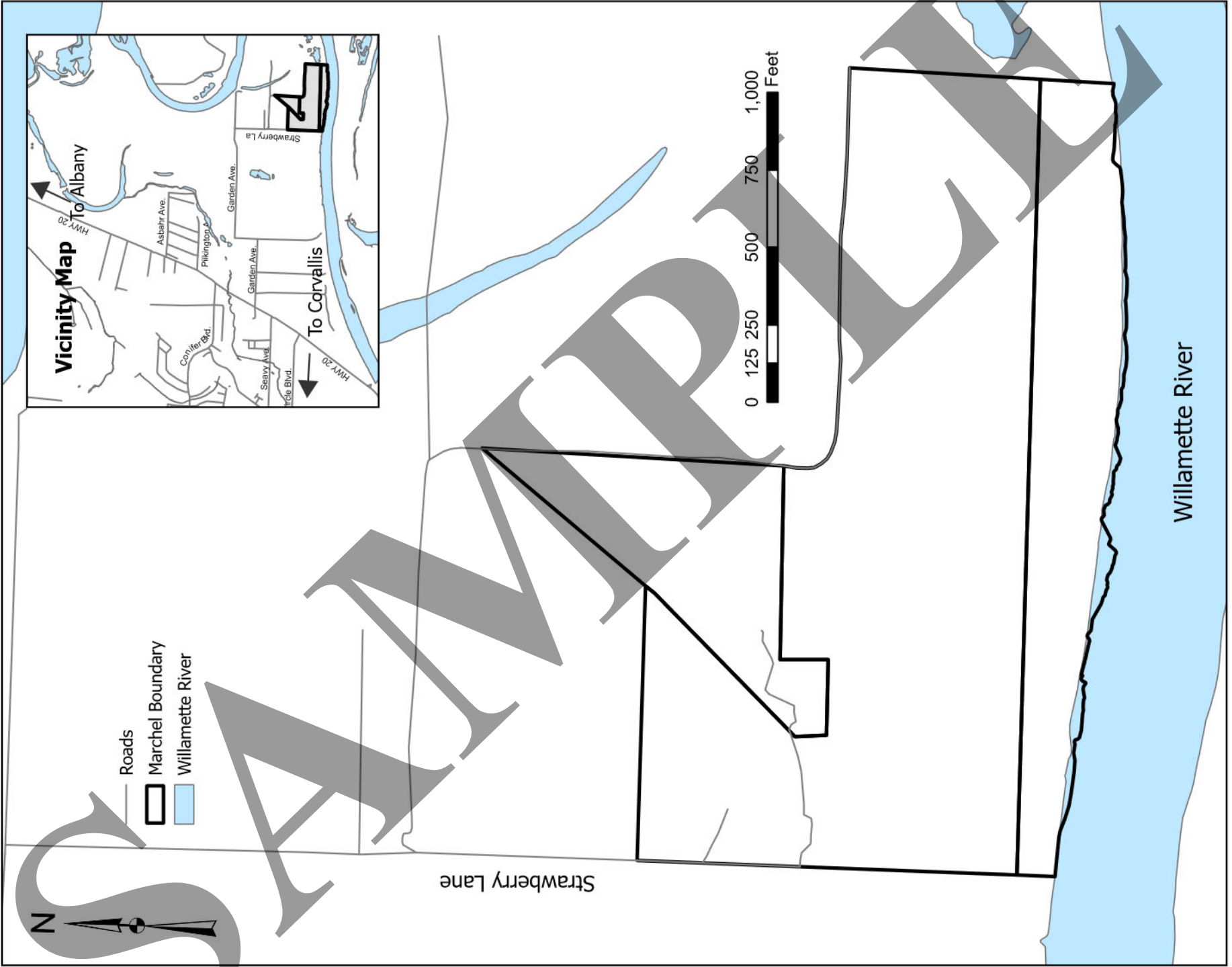

OSU Matteson Forest Washington County, OR

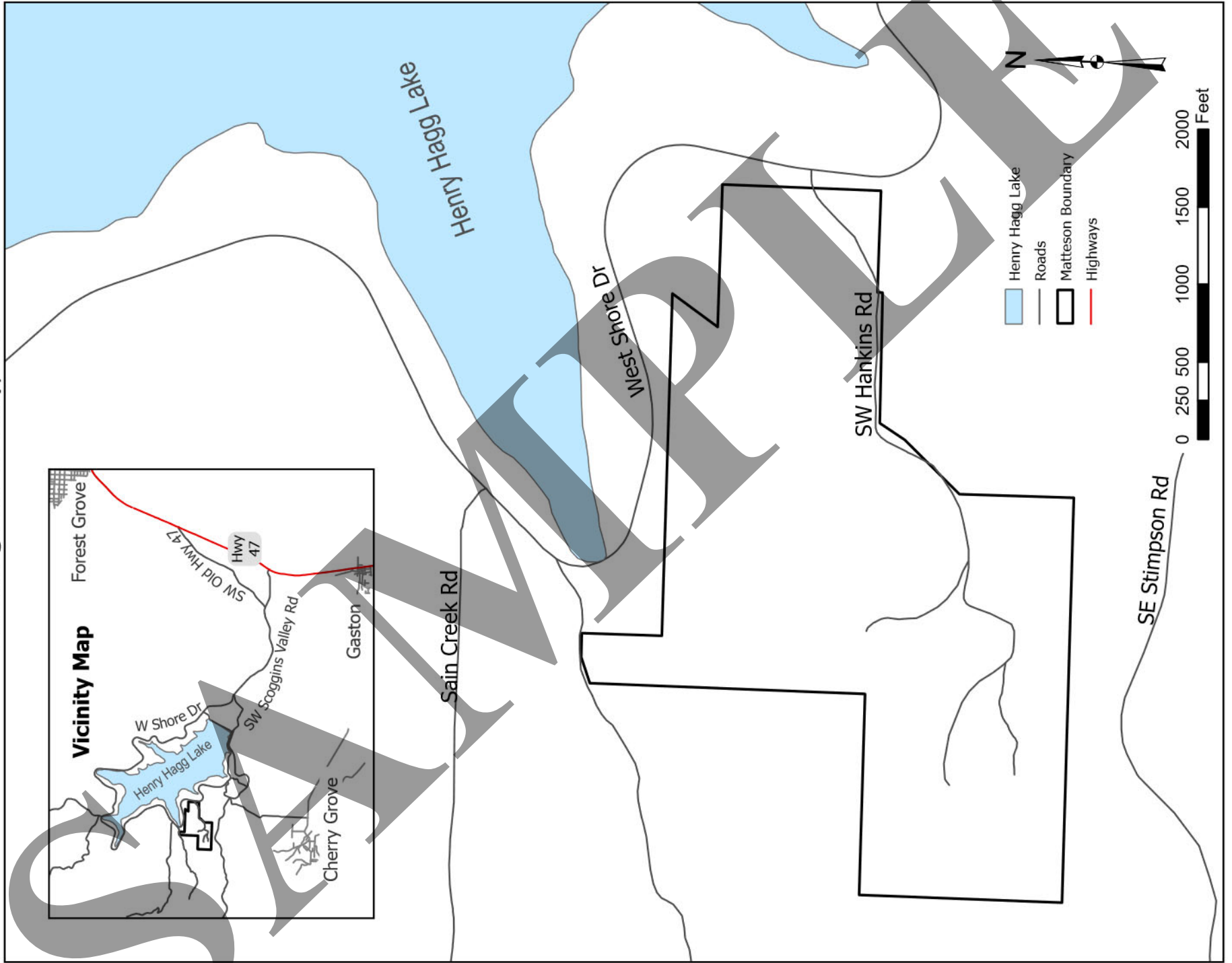

OSU McDonald-Dunn Forest
Benton County, OR

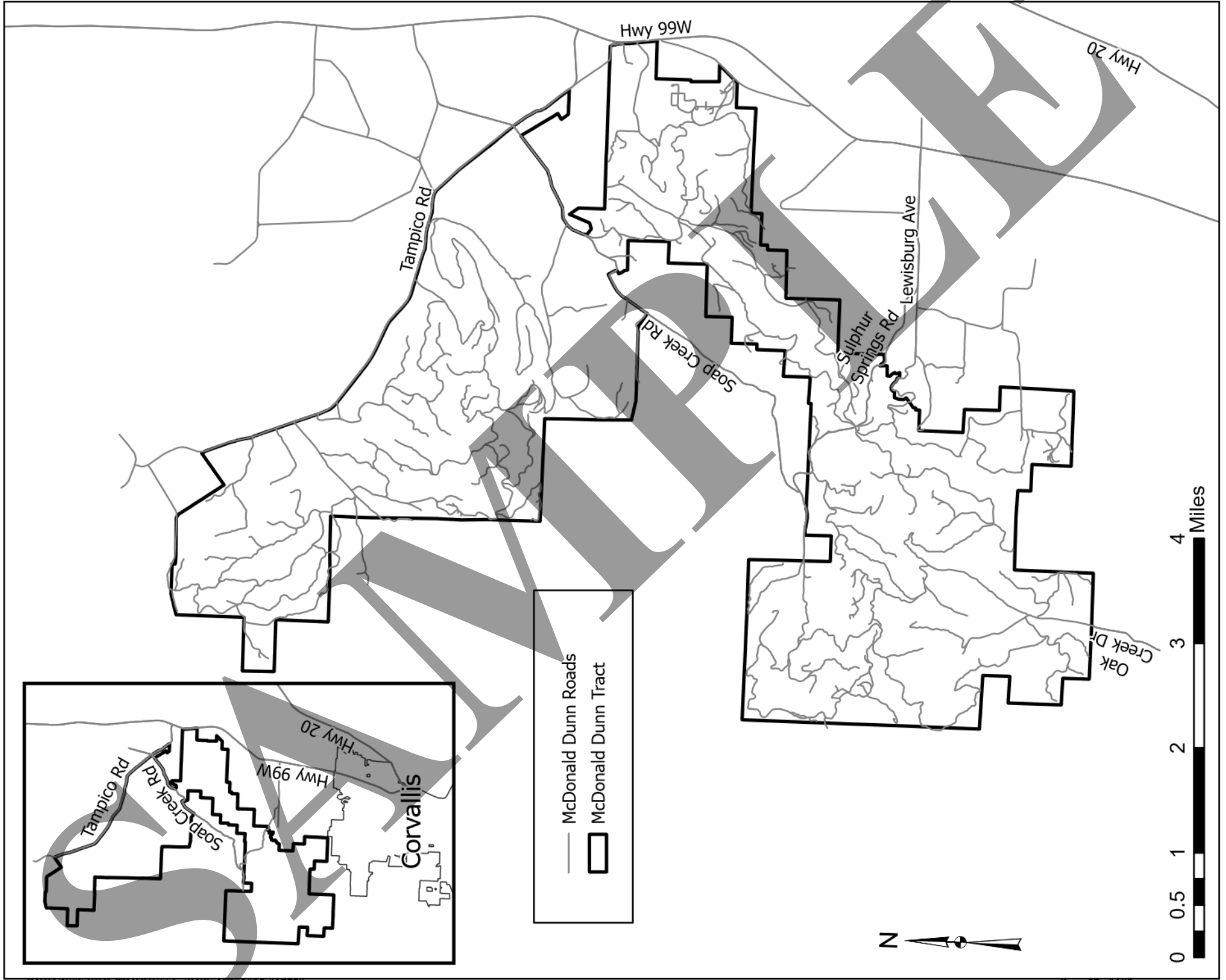

OSU Oberteuffer Forest
Union County, OR

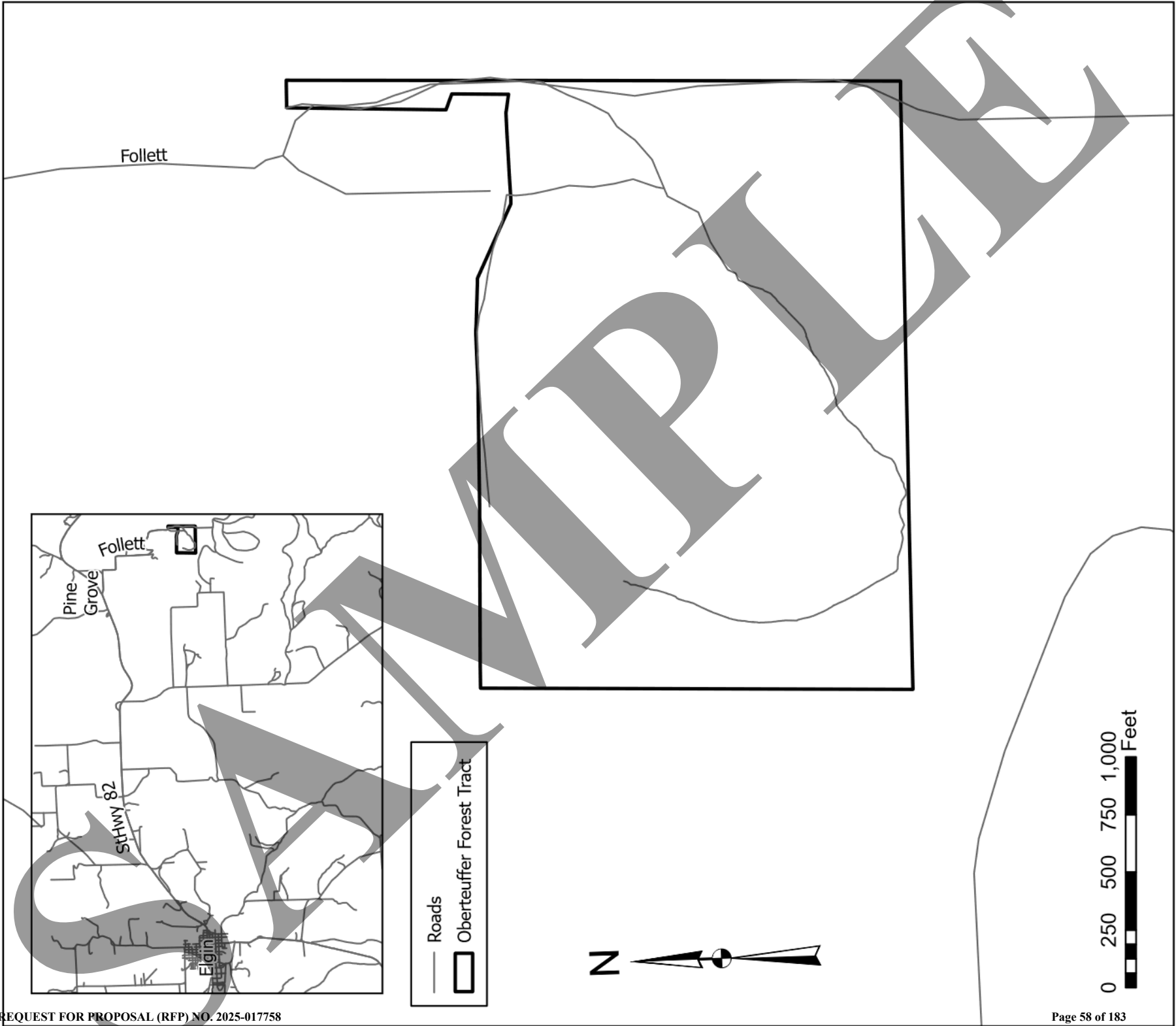

Ram's Dell
Clackamas County, OR

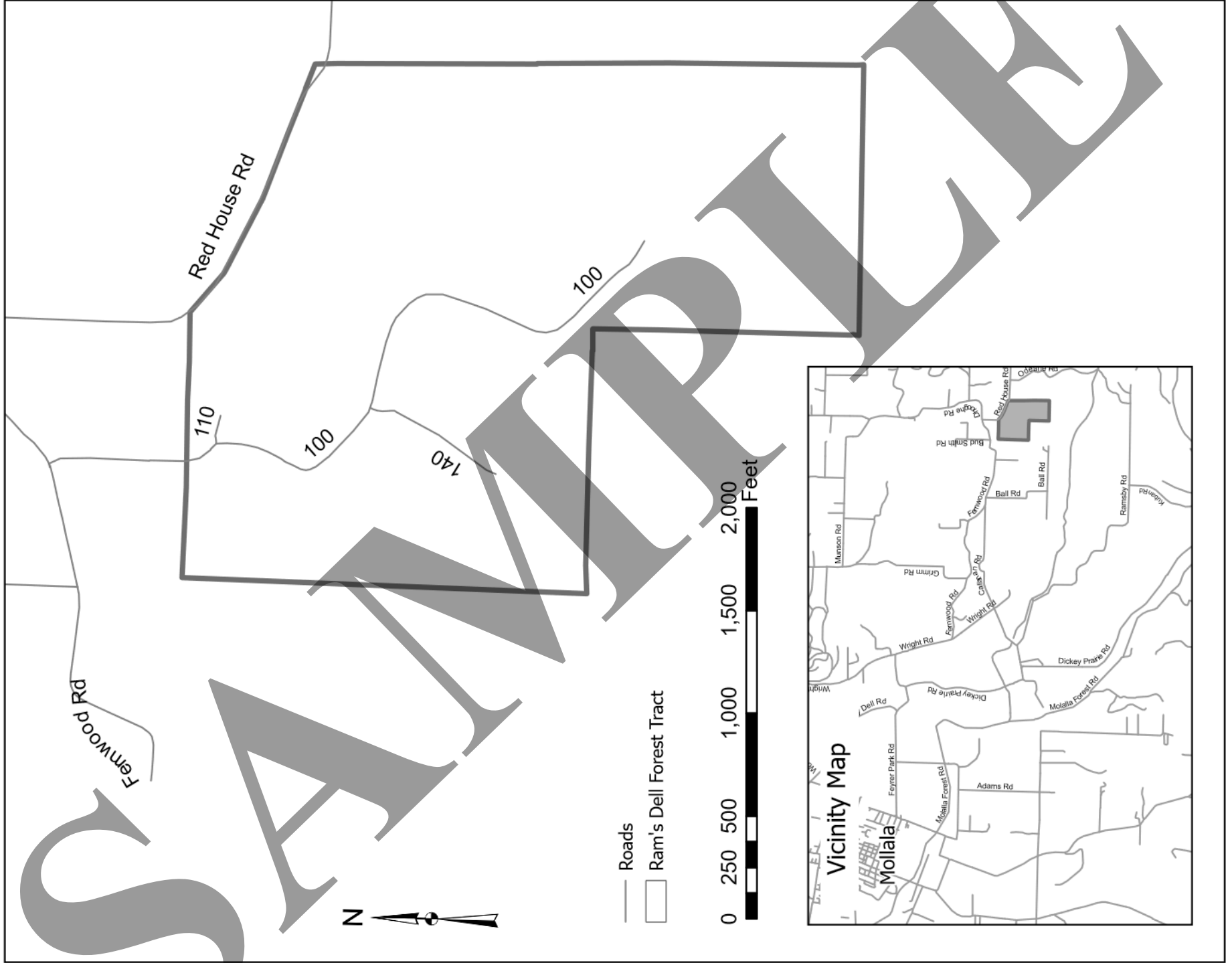

Exhibit E
Schedule of Items

SAMPLE

Schedule of Items

Item No.	Exhibit or Spec.	Schedule of Items	Qty	Unit	Unit Price	Total Price
1	N/A	Consultation	10	HOUR		
2	Tech Specs 4	Mobilization to Benton County	1	EA		
3	Tech Specs 4	Mobilization to Blodgett Tract	1	EA		
4	Tech Specs 4	Mobilization to Ram's Dell Tract	1	EA		
5	Tech Specs 4	Mobilization to Matteson Tract	1	EA		
6	Tech Specs 4	Mobilization to Collins Tract	1	EA		
7	Tech Specs 7 (C3}	Equipment Cleaning	2	EA		
8	Tech Specs 19	Furnish & Install 18" Culvert	40	LF		
9	Tech Specs 19	Furnish & Install 24" Culvert	40	LF		
10	Tech Specs 19	Furnish & Install 36" Culvert	40	LF		
11	Tech Specs 19	Furnish & Install 48" Culvert	40	LF		
12	Tech Specs 17	Delivered Aggregate 3/8"-minus to Benton County	25	TON		
13	Tech Specs 17	Delivered Aggregate 3/4"-minus to Benton County	25	TON		
14	Tech Specs 17	Delivered Aggregate 1"-minus to Benton County	40	TON		
15	Tech Specs 17	Delivered Aggregate 1"-Open to Benton County	40	TON		
16	Tech Specs 17	Delivered Aggregate 1-1/4"-Open to Benton County	40	TON		
17	Tech Specs 17	Delivered Aggregate 1-1/2"-minus to Benton County	200	TON		
18	Tech Specs 17	Delivered Aggregate 1-1/2" - Open to Benton County	40	TON		

Schedule of Items

Item No.	Exhibit or Spec.	Schedule of Items	Qty	Unit	Unit Price	Total Price
19	Tech Specs 17	Delivered Aggregate 3"-minus to Benton County	200	TON		
20	Tech Specs 17	Delivered Aggregate 4-6" Open to Benton County	40	TON		
21	Tech Specs 17	Delivered Aggregate Jaw Run to Benton County	40	TON		
22	Tech Specs 17	Delivered Aggregate Shot Rock to Benton County	40	TON		
23	Tech Specs 17	Delivered Aggregate Class 700 Rip Rap Benton County	40	TON		
24	Tech Specs 17	Delivered Aggregate Class 700 Rip Rap Blodgett Tract	40	TON		
25	Tech Specs 17	Delivered Aggregate 1 ½"-minus Blodgett Tract	40	TON		
26	Tech Specs 17	Delivered Aggregate 3"-minus Blodgett Tract	40	TON		
27	Tech Specs 17	Delivered Aggregate Jaw Run Blodgett Tract	14	TON		
28	Tech Specs 17	Delivered Aggregate Shot Rock Blodgett Tract	14	TON		
29	Tech Specs 12	Cutting Side Vegetation	1	SIDE MILE		
30	Tech Specs 18 (B)	Blading Surfaced Roads, Compaction B	1	MILE		
31	Tech Specs 18 (B)	Blading Surfaced Roads, Compaction C	1	MILE		
32	Tech Specs 18 (A)	Clean and Reshape Drainage Ditch	1	MILE		
33	Tech Specs 11 (A1)	Dozer	10	HOUR		
34	Tech Specs 11 (A2)	Mini Excavator	10	HOUR		
35	Tech Specs 11 (A3)	Small Excavator	20	HOUR		
36	Tech Specs 11 (A4)	Medium Excavator	40	HOUR		

Schedule of Items

Item No.	Exhibit or Spec.	Schedule of Items	Qty	Unit	Unit Price	Total Price
37	Tech Specs 11 (AS)	Large Excavator	40	HOUR		
38	Tech Specs 11 (AG)	Front End Loader	10	HOUR		
39	Tech Specs 11 (A7)	Backhoe	10	HOUR		
40	Tech Specs 11 (A8)	Grader	40	HOUR		
41	Tech Specs 11 (A9)	Roller	40	HOUR		
42	Tech Specs 11 (A10)	Dump Truck	20	HOUR		
43	Tech Specs 11 (All)	Self-Loading Log Truck	10	HOUR		
44	Tech Specs 11 (A12)	Log Truck	10	HOUR		
45	Tech Specs 11 (AB)	Water Truck	10	HOUR		
46	Tech Specs 11 (A14)	Log Loader	20	HOUR		
47	Tech Specs 11 (AIS)	Brushing Tractor	40	HOUR		
48	Tech Specs 11 (A16)	Trailer Mounted Mulcher	10	HOUR		
49	Tech Specs 11 (A17)	Laborer/Tools	10	HOUR		
50	Tech Specs 11 (B)	Move Equipment, Tilt Top Trailer	5	HOUR		
51	Tech Specs 11 (B)	Move Equipment, Lowboy	5	HOUR		
52	OR Seed Cert. Service	Grass Seed: Annual Rye; Endophyte & Weed Free	100	LB		
53	N/A	Straw Bale, Wheat/ Oat straw, weed free	10	EA		
54	ASTM D6461	Silt Fence, 3-foot height	so	LF		

Schedule of Items

Item No.	Exhibit or Spec.	Schedule of Items	Qty	Unit	Unit Price	Total Price
55	AASHTO M-288-06	Geotextile Fabric, Woven Class 3	200	SY		

SAMPLE

**Exhibit F
Key Personnel**

Title	Name
Title	Name
Title	Name
Title	Name
Title	Name
Title	Name

SAMPLE

SAMPLE

OREGON STATE UNIVERSITY

PAYMENT BOND

Bond No. _____
Solicitation _____
Project Name _____

_____ (Surety #1) Bond Amount No. 1: \$ _____
_____ (Surety #2)* Bond Amount No. 2:* \$ _____
* *If using multiple sureties* Total Penal Sum of Bond: \$ _____

We, _____, as Principal, and the above identified Surety(ies), authorized to transact surety business in Oregon, as Surety, hereby jointly and severally bind ourselves, our respective heirs, executors, administrators, successors and assigns firmly by these presents to pay unto Oregon State University (OSU) the sum of (Total Penal Sum of Bond) _____ (Provided, that we the Sureties bind ourselves in such sum "jointly and severally" as well as "severally" only for the purpose of allowing a joint action or actions against any or all of us, and for all other purposes each Surety binds itself, jointly and severally with the Principal, for the payment of such sum only as is set forth opposite the name of such Surety), and

WHEREAS, the Principal has entered into contract No. _____ with OSU, the plans, specifications, terms and conditions of which are contained within the Contract resulting from the above-referenced Solicitation;

WHEREAS, the terms and conditions of the contract, together with applicable plans, standard specifications, special provisions, schedule of performance, and schedule of contract prices, are made a part of this Payment Bond by reference, whether or not attached to the contract (all hereafter called "Contract"); and

WHEREAS, the Principal has agreed to perform the Contract in accordance with the terms, conditions, requirements, plans and specifications, and schedule of contract prices which are set forth in the Contract and any attachments, and all authorized modifications of the Contract which increase the amount of the work, or the cost of the Contract, or constitute authorized extensions of time for performance of the Contract, notice of any such modifications hereby being waived by the Surety:

NOW, THEREFORE, THE CONDITION OF THIS BOND IS SUCH that if the Principal shall (1) faithfully and truly observe and comply with the terms, conditions and provisions of the Contract, in all respects, (2) shall well and truly and fully do and perform all matters and things by it undertaken to be performed under said Contract and any duly authorized modifications that are made, upon the terms set forth therein, and within the time prescribed therein, or as extended therein as provided in the Contract, with or without notice to the Sureties, (3) shall save, defend, indemnify and hold harmless OSU, and its officers, board members, employees, agents and other representatives, against any claim for direct or indirect damages of every kind and description that shall be suffered or claimed to be suffered in connection with or arising out of the performance of the Contract by the Contractor or its subcontractors, (4) shall promptly pay all persons supplying labor, materials or both to the Principal or its subcontractors for prosecution of the work provided in the Contract; (5) shall promptly pay all contributions due the State Industrial Accident Fund and the State Unemployment Compensation Fund from the Principal or its

subcontractors in connection with the performance of the Contract; (6) shall pay over to the Oregon Department of Revenue all sums required to be deducted and retained from the wages of employees of the Principal and its subcontractors pursuant to ORS 316.167;(7) shall permit no lien nor claim to be filed or prosecuted against the State or OSU on account of any labor or materials furnished; and (8) shall do all things required of the Principal by the laws of this State, then this obligation shall be void; otherwise, it shall remain in full force and effect.

Nonpayment of the bond premium will not invalidate this bond, nor shall OSU be obligated for the payment of any premiums.

This bond is given and received under authority of ORS Chapters 279C and 352, the provisions of which hereby are incorporated into this bond and made a part hereof.

IN WITNESS WHEREOF, WE HAVE CAUSED THIS INSTRUMENT TO BE EXECUTED AND SEALED BY OUR DULY AUTHORIZED LEGAL REPRESENTATIVES:

Dated this _____ day of _____, 20__.

PRINCIPAL: _____

By _____

Signature

Official Capacity

Attest: _____

Corporation Secretary

SURETY: _____

[Add signatures for each if using multiple bonds]

BY ATTORNEY-IN-FACT:

[Power-of-Attorney must accompany each bond]

Name

Signature

Address

City State Zip

Phone Fax

OREGON STATE UNIVERSITY

PERFORMANCE BOND

Bond No. _____
Solicitation _____
Project Name _____

_____ (Surety #1) Bond Amount No. 1: \$ _____
_____ (Surety #2)* Bond Amount No. 2:* \$ _____
* If using multiple sureties Total Penal Sum of Bond: \$ _____

We, _____ as Principal, and the above identified Surety(ies), authorized to transact surety business in Oregon, as Surety, hereby jointly and severally bind ourselves, our respective heirs, executors, administrators, successors and assigns firmly by these presents to pay unto Oregon State University (OSU), the sum of (Total Penal Sum of Bond)

(Provided, that we the Sureties bind ourselves in such sum "jointly and severally" as well as "severally" only for the purpose of allowing a joint action or actions against any or all of us, and for all other purposes each Surety binds itself, jointly and severally with the Principal, for the payment of such sum only as is set forth opposite the name of such Surety), and

WHEREAS, the Principal has entered into contract No. _____ with the OSU, the plans, specifications, terms and conditions of which are contained within the Contract resulting from the above-referenced Solicitation;

WHEREAS, the terms and conditions of the Contract, together with applicable plans, standard specifications, special provisions, schedule of performance, and schedule of Contract prices, are made a part of this Performance Bond by reference, whether or not attached to the contract (all hereafter called "Contract"); and

WHEREAS, the Principal has agreed to perform the Contract in accordance with the terms, conditions, requirements, plans and specifications, and all authorized modifications of the Contract which increase the amount of the work, the amount of the Contract, or constitute an authorized extension of the time for performance, notice of any such modifications hereby being waived by the Surety:

NOW, THEREFORE, THE CONDITION OF THIS BOND IS SUCH that if the Principal herein shall (1) faithfully and truly observe and comply with the terms, conditions and provisions of the Contract, in all respects, (2) shall well and truly and fully do and perform all matters and things undertaken by Contractor to be performed under the Contract, upon the terms set forth therein, and within the time prescribed therein, or as extended as provided in the Contract, with or without notice to the Sureties, (3) shall save, defend, indemnify and hold harmless OSU and its officers, board members, employees, agents and other representatives, against any direct or indirect damages or claim of every kind and description that shall be suffered or claimed to be suffered in connection with or arising out of the performance of the Contract by

the Principal or its subcontractors, and (4) shall in all respects perform said contract according to law, then this obligation is to be void; otherwise, it shall remain in full force and effect.

Nonpayment of the bond premium will not invalidate this bond, nor shall OSU be obligated for the payment of any premiums.

This bond is given and received under authority of ORS Chapters 279C and 352, the provisions of which hereby are incorporated into this bond and made a part hereof.

IN WITNESS WHEREOF, WE HAVE CAUSED THIS INSTRUMENT TO BE EXECUTED AND SEALED BY OUR DULY AUTHORIZED LEGAL REPRESENTATIVES.

Dated this _____ day of _____, 20__

PRINCIPAL: _____

By _____

Signature

Official Capacity

Attest: _____

Corporation Secretary

SURETY: _____

[Add signatures for each surety if using multiple bonds]

BY ATTORNEY-IN-FACT:

[Power-of-Attorney must accompany each surety bond]

Name

Signature

Address

City

State

Zip

Phone

Fax

SAMPLE

Technical Specifications

Includes:

Permits	Section 1
Seasonal Restrictions	Section 2
Access	Section 3
Mobilization	Section 4
Maintenance During Use	Section 5
Damage to Forest Property and Timber	Section 6
Protection of Watershed	Section 7
Fire Prevention	Section 8
Protection of Culturally Sensitive Areas	Section 9
Water Supply and Dewatering	Section 10
Equipment Rental	Section 11
Roadside Clearing	Section 12
Clearing and Grubbing	Section 13
Disposal	Section 14
Compaction	Section 15
Earthwork	Section 16
Surfacing	Section 17
Road Reconditioning	Section 18
Culvert Replacement	Section 19
Culvert Maintenance	Section 20

1) **PERMITS**

- A) Owner has prepared or will prepare the required Forest Practices Act (FPA) "Notice of Operations".
- B) Prior to commencing any operations, Contractor shall read and become familiar with the Forest Practice Notice and any Written Plans required for services to be performed under this Contract.
- C) Any changes to the plan must have Owner approval. Contractor shall comply with all provisions of the Written Plan.

2) **SEASONAL RESTRICTIONS**

- A) "Live" stream work shall be limited to the State "In-Water Work" period, unless otherwise approved in writing by Oregon Department of Forestry and the Owner.
<https://www.dfw.state.or.us/lands/inwater/2024%20Oregon%20In-Water%20Work%20Guidelines.pdf>
- B) From September 15 through June 15 the Contractor will operate all vehicles over 10,000 GVW at reduced tire pressures. The steering axles of these Vehicles shall be at 91 psi and the drive axles shall be at 71 psi.

3) **ACCESS**

- A) Except as otherwise provided for in this contract, Contractor shall have the right of access over, in, and through any Forest Tract listed in this contract, for the purpose of performing the operations. Contractor in so using, improving, or constructing roads, shall at no time have an interest in the land or timber other than the right of access.
- B) Contractor shall be responsible for obtaining all road use permits, paying any road use fees, and performing any maintenance associated with haul tributary to the Listed Tracts.
- C) Contractor shall comply with all applicable terms and conditions of any access documents set forth in the provisions of this contract, which may include requirements to furnish evidence of insurance coverage, performance bond, entering into a third-party agreement, maintenance, or other actions.

4) **MOBILIZATION**

This work consists of moving personnel, equipment, material, and incidentals to the project and performing work necessary before beginning work at the project site. This work also includes obtaining permits, insurance, and bonds.

- A) When the contract establishes separate work periods within the contract time any additional mobilization included as a Bid Item will be retained until the actual work period.
- B) The contract amount for mobilization shall include full compensation for furnishing all labor, materials, tools, equipment and incidentals involved in mobilization.

5) MAINTENANCE DURING USE

Contractor's responsibility for normal road maintenance commences with Contractor's first use of a road for any activity under the contract. Contractor's responsibility shall continue through any active periods until final acceptance of the maintenance is made by Owner. Normal road maintenance applies to all existing roads used for any activity under this contract. A road which is constructed or reconstructed by Contractor shall assume the status of an existing road upon acceptance in writing by Owner. Normal maintenance shall be inclusive of work needed to protect the road from seasonal weather damage, restore damage caused by road use, and safeguard soil, water, and drainage structures, as follows:

- A) While performing normal road maintenance work, Contractor shall not contaminate gravel or bituminous road surfaces by covering or mixing earth or debris from ditches, slides, or other sources. Contractor shall maintain the existing cross section of dirt or graveled roads by blading and shaping the surface and shoulders. Banks shall not be undercut. Contractor shall not waste any of the surface material from the roads by blading it into ditches or off shoulders. Established berms shall be maintained. Additional berms shall be placed where needed to protect fills. Owner may require cross ditching on certain roads. Contractor shall patch and place additional rock on gravel road surfaces as necessary to repair damage and restore the road.
- B) While performing the operations, Contractor shall minimize damage to ditches, cut banks, fill slopes, and road surfaces. Where damage does occur, Contractor shall restore the road to its original condition, as directed by Owner. No track-mounted machinery shall cross any bridge or pavement without first providing a protective barrier between the tracks and surface. The barrier shall be adequate to protect the surface.
- C) Prior to any inactive periods, drainage systems shall be re-established so that exposed soil will not erode into waters of the State and drainage water will not saturate fills.
- D) During active periods, Contractor is responsible for maintenance needs that are caused by public use of the road and that can be accomplished under the terms of normal maintenance. Upon written approval from Owner, Contractor may restrict use of the roads by others. Measures may include signing, gating, or blocking off the road. Approval of measures by Owner does not relieve Contractor from normal maintenance responsibilities during active periods in the event that such measures do not restrict vehicular traffic.
- E) Should Contractor jointly share maintenance responsibilities with other authorized parties to use the roads, then each party shall be responsible for a proportionate part of normal maintenance, based upon the ratio of each party's use to total road use, as determined by Owner. Owner may determine when maintenance is needed and issue instructions to Contractor specifying the work to be done and the date by which it must be completed.
- F) Contractor shall perform all cleanup including the removal of bank slough, minor slides, and fallen timber. This material shall be deposited at the closest location identified by Owner. Contractor shall replace material eroded from fill slopes and clean out drainage ditches and culverts.
- G) Contractor shall be required to place and maintain straw bales for filtering road run-off water before it enters waters of the State upon direction from owner.

6) DAMAGE TO FOREST PROPERTY AND TIMBER

- A) Contractor shall comply with the most current Oregon Forest Practices rules and regulations and otherwise perform the service in accordance with all applicable laws. Contractor shall exercise all reasonable precautions to protect forest ecosystems, roads, and facilities in and adjacent to designated work areas in accordance with instructions and guidelines of the Owner. Contractor shall be held responsible for any violations and fines that result from negligence or misconduct on the Contractor's part.
- B) Contractor shall be exclusively responsible for any damage to reserved timber. If, however, damage to reserved timber occurs and is determined unavoidable by Owner, in Owner's sole and exclusive discretion, then no charge will be made for damage.
- C) If Contractor's activities result in avoidable damage to reserved timber, in Owner's sole and exclusive discretion, Contractor shall fairly compensate Owner at the following rates:
- 1) Single the stumpage value shall be paid to Owner when:
 - a) "Minor damage" defined as bark removed down to the cambium layer of a tree, such removal affecting at least twenty-four (24) square inches, but less than damage defined as "major damage", to reserved timber occurs during the course of normal operations.
 - b) Trees must be cut in order to facilitate operations, or for safety around work sites, without prior approval of Owner.
 - 2) Double the stumpage value shall be paid when:
 - a) "Major damage" defined as bark removed down to the cambium layer over an area of the bole which has one dimension (height or circumference) greater than the diameter of the tree, or any visible bark removal on the tree roots.
 - b) More than 50 percent of live crown is removed.
 - c) Tree is knocked down or leaning more than 10 degrees from vertical.
 - 3) Triple the stumpage value shall be paid when:
 - a) Reserved timber is intentionally cut or removed;
 - b) Reserved timber is intentionally damaged;
 - c) Repeated major damage occurs to reserved timber;
 - d) Any intentional "notching" or undercutting of reserved timber occurs.
- D) Contractor shall keep all Owner property free from any adverse liens, security interests or encumbrances and shall not commit or permit waste or destruction of Owner property.

7) **PROTECTION OF WATERSHED**

- A) Contractor shall take all necessary precautions to prevent damage to stream banks, any stream course, lake, reservoir, or forested wetland within or adjacent to the project area. Definitions of Type F, Type D, Type N streams and springs, bogs or wetlands contained in the Oregon Forest Practices Act apply to this Contract. Prior to commencing any operations, Contractor shall read and become familiar with the forest practice notice and any written plans required for services to be performed under this Contract.
- B) Stream Clearance: Contractor shall comply with the following instructions for removal of debris that enters streams as a result of Contractor's operations.
- 1) Debris entering all streams shall be removed by the end of operations each day, unless an alternate practice is approved by Owner.
 - 2) Contractor shall notify Owner when debris more than two (2) inches in diameter on the small end and more than six (6) feet in length enters Type F and Type D streams. Contractor shall either leave or remove such debris as directed by Owner.
 - 3) Debris entering Type N streams shall be removed within 14 days of completion of operations.
 - 4) Debris shall be cleared up to the high water mark on all streams. All removed debris shall be placed in a stable location, approved by Owner, above the high water mark.
 - 5) In addition to other protective measures required by Owner, this Contract or professional standards, Contractor shall discontinue all or part of the operations under this Contract upon notice from Owner that operations will cause excessive damage to the watershed, in Owner's sole opinion.
- C) Contractor shall take all precautions necessary to protect the watershed from damage and to prevent pollution to the water supply. Precautions shall include, but not be limited to, the following:
- 1) **Laws, Rules and Regulations:** Comply with Oregon laws and with the rules and regulations of the Oregon State Board of Health relative to protection of watersheds and sanitation of public water supply.
 - 2) **General Sanitary Conditions:** Do not create any conditions which may permit breeding of flies or mosquitoes. Machinery, equipment, soil, and fuel storage shall not be located near streams. Waste oil will be removed from the watershed.
 - 3) Contractor shall wash all equipment prior to entering the Research Forests property and prior to exiting the Research Forests property.

- 4) Privies: When work occurs at the same location for more than five (5) consecutive days, place a clean, sanitary, and usable privy at each work site and other main points of operation and require all personnel to use the privies. Privies shall be placed at locations approved by Owner not closer than 100 feet to any stream. The privies shall be constructed as follows, unless other types are approved by Owner prior to being placed in use:
 - a) The housing shall be waterproof and flyproof, and the toilet shall be equipped with a seat and cover.
 - b) A receptacle of not less than 45-gallon capacity shall be provided for all refuse and the privy shall be equipped with a separate urinal draining into the receptacle. Refuse shall be removed from the receptacle and disposed of off the watershed area.
 - c) The receptacle shall be vented through the roof of the privy housing.
 - d) Pit type privies shall not be permitted on the watershed.
- 5) Overnight Camping Prohibited: No person shall remain on the watershed overnight, unless authorized in advance in writing by Owner.

8) FIRE PREVENTION

- A) Contractor shall take adequate measures for the prevention and suppression of fire in conformance with the requirements of the Oregon statutes and the State Forester's regulations. The Owner will check that the Contractor complies with fire rules and regulations at the beginning of each fire season or upon random inspections. The Owner or Oregon Department of Forestry's (ODF) Fire Protection Officer will also conduct spot inspections to ensure that the fire equipment is operational and that Contractor is maintaining a fire safe work site.
- B) Contractor shall suspend operations as needed to conform to the State Forester's regulations, or when, in the judgment of Owner, such suspension is considered necessary for fire safety, and Contractor shall not resume operations until authorized to do so by the Owner. At Owner's request, Contractor shall close active operating areas to other forest users during suspensions to protect persons and equipment and limit liability of Owner and Contractor due to the actions of third parties.
- C) In the event of fire on the Research Forests, or along roads used by the Contractor in any operation, Contractor shall immediately exert every reasonable effort to control, extinguish and prevent the spread of such fire.

9) PROTECTION OF CULTURALLY SENSITIVE AREAS

- A) Location of known historic or prehistoric sites, buildings, objects and properties relating to American history, architecture, archaeology and culture, such as settler or Indian artifacts, protected by Federal and State laws including but not limited to the National Historic Preservation Act (NHPA) of 1966, Section 106, codified in 36 CFR Part 800 (Protection of Historic Properties), ORS 97.740-97.760, 97.990(5) and (6), 358.635-358.653, 358.680-358.690, 358.905-358.961, 390.235-390.240 and OAR Chapter 736, Division 51 shall be identified on the ground by Owner and shown on Contract maps.
- B) Owner may unilaterally modify or cancel all or portions of this Contract to protect an area, object of antiquity, artifact, or similar object which is or may be entitled to protection under these statutes and rules regardless of when the area, object or artifact is discovered or identified. Discovery of such areas by either party shall be promptly reported to the other party and operations will be suspended at that location until the significance or potential significance of the site is determined by Owner.
- C) In the event of Contract modification under this subsection, Contractor shall be reimbursed for any required additional protection measures beyond the scope of this Contract, provided that any work or extra protection required shall be subject to prior approval by Owner. The amount of reimbursement shall be determined by Owner and shall not exceed expended or agreed-upon costs.
- D) Contractor shall protect through avoidance or use of designated travel routes all known and identified historic and prehistoric sites, buildings, objects and properties related to American history, architecture, archaeology, and culture against destruction, obliteration, removal or damage during the Contractor's operations. Contractor and all persons employed by Contractor are prohibited from picking up and removing any cultural resources. Contractor shall bear costs of evaluation and restoration if negligent in its operations in accordance with statutes and rules referenced in this section. Such payment shall not relieve Contractor from civil or criminal remedies otherwise provided by law. Civil sanctions include but are not limited to sole liability for all costs associated with monitoring, recovery, site restoration or other archeological work required by Tribal, Federal, or State authorities.
- E) Prior to any ground disturbing activity, the Contractor shall meet with the Owner and other appropriate parties on site prior to beginning work to ensure that all parties understand the locations of the culturally sensitive sites and the measures that shall be taken to protect them.

10) WATER SUPPLY AND DEWATERING

- A) Suitable and adequate water sources and use restrictions will be designated by Owner at the start of each project. If the Contractor elects to provide water from other than designated sources the Contractor shall be responsible to obtain the right to use the water including any cost for royalties involved. The rate of applications shall be based on the gallonage per mile ordered by the Owner, or as specified in other pay items.
- B) Mobile watering equipment shall have watertight tanks of known capacity. If tank capacity is not known, it shall be measured and certified by the Contractor prior to use.
- C) Positive control of water application is required. Equipment shall provide uniform application of water without puddling or washing.

- D) An air gap or positive anti-siphon device shall be provided between the water source and the vehicle being loaded if the vehicle has been used for other than water haul if the source is a domestic potable water supply, or the water is used for tank mixing with any other materials.
- E) The designated water sources may require some work prior to their use. Such work may include cleaning ponded areas, installing temporary weirs or sandbags, pipe repair, pump installation or other items (appropriate to the Contractor's operations). Flowing non-fish streams may be temporarily sandbagged or a weir placed to pond water. Contractor shall obtain approval on improvements for sandbags or weirs prior to placement. Drafting or diverting water from fish bearing streams may not exceed 10% of the available flow and fish screens must be installed, operated, and maintained according to National Marine Fisheries Service's (NMFS) fish screen criteria. At a minimum, screen openings shall not exceed 3/32 or 0.0938 inches. All dewatering pumping will follow the same guidelines.
- F) Contractor shall submit a written dewatering plan for all operations in live streams that will require channel diversion or dewatering. Owner and State approval of the plan are required prior to commencing any in-stream work.
- G) Unless specified in the Schedule of Items, development of water supply sources shall be incidental to work ordered. If in the Schedule of Items, measurement for development of water supply sites will be the number of sites ordered and accepted.
- H) Unless specified in the Schedule of Items as watering for a specific Section of these specifications, measurement of water haul and application will be incidental. If indicated in the Schedule of Items, measurement shall be M-GALLONS (1,000 gallons) using calibrated tanks, distributors, or accurate water meters furnished by the Contractor. Hauling shall be incidental. In no case will payment be made for more gallons than ordered by the Owner.

11) EQUIPMENT RENTAL

This Section establishes the basis for the Owner to order work not otherwise included in the contract.

- A) Equipment under this Section shall be provided with a fully qualified operator. All equipment with an enclosed cab shall have a fully operational CB radio. In addition, the ordered equipment shall be furnished on a fully operational basis, of modern design, in good operating condition with no fuel or oil leaks and shall meet the following minimum specifications:
 - 1) Dozer - 130 HP, power 6-way blade, rear rippers/scarifiers.
 - 2) Mini Excavator - 15,000 lb. operating weight, 50 HP, hydraulic thumb, available 12" and muck/grading bucket.
 - 3) Small Excavator - 26,000 lb. operating weight, 90 HP, hydraulic thumb, available muck/grading bucket and hydraulic compactor.
 - 4) Medium Excavator - 42,000 lb. operating weight, 130 HP, appx. 1.2 CY bucket, hydraulic thumb, available clamshell bucket and hydraulic compactor.
 - 5) Large Excavator - 62,000 lb. operating weight, 200 HP, appx. 1.5 CY bucket.
 - 6) Front End Loader - 200 HP, 3 CY bucket, wheeled.

- 7) Backhoe - Digging depth 15 feet, 85 HP, 24-inch backhoe bucket and 1.2 CY loader bucket.
 - 8) Grader - 130 HP, 12 foot moldboard, blade to be equipped with carbide teeth, available rear rippers/scarifiers.
 - 9) Roller - Single drum vibratory and padfoot available, 66-inch drum, 96 HP.
 - 10) Dump Truck- Highway legal, 10 CY dump box, 400 HP.
 - 11) Self-Loading Log Truck - Highway legal, 80,000 GVW, 400 HP, log loading boom and grapple.
 - 12) Log Truck - Highway legal, 80,000 GVW, 400 HP.
 - 13) Water Truck - Highway legal, 250 HP, 4000-gallon capacity, self-filling capability, front and rear discharge nozzles.
 - 14) Log Loader - 130 HP, log-loading grapple and heel boom, 34-foot reach.
 - 15) Brushing tractor - 70 HP, PTO, rotary side mounted mower with 5.5-foot blade and 50 HP.
 - 16) Trailer Mounted Mulcher - 7 tons per hour, 34 HP.
 - 17) Laborer - with required hand tools including: chain saw, hand compactor, flagging equipment (as required). Laborer time spent flagging will be reported as "Flagger".
- B) The Owner, in conjunction with the Contractor, will determine if equipment is to be moved onto and off the site by roading under its own power or by use of Contractor's truck transport. The Work Order will include the method of moving as roading or transport. Subsequent moving of equipment from one portion of the job to another shall be by roading unless otherwise documented in the Work Order. Time for equipment roading will commence with the beginning of the move. Time will be counted for the operator during roading. When equipment is not being actively used on the Project at the time moving is ordered under this Section, time will be counted for the transporting vehicle, but not the equipment being transported.
- C) The Contractor will maintain a daily record showing the actual hours, to the nearest quarter (0.25) hour, that the equipment is in operation and/or laborer is performing work under this item. The Owner and Contractor will rectify differences in recorded hours prior to billing.

12) ROADSIDE CLEARING

- A) Brush, trees, and other vegetation less than four (4) inches in diameter within each area treated shall be cut to a maximum height of six (6) inches above the ground surface or obstruction such as rocks or existing stumps. When work is performed under this section, the Contractor shall remove all limbs which extend into the treated area or over the roadbed to a height of fifteen (15) feet above the traveled way surface elevation.
- B) Signs, markers, and other road related structures, are designated to be retained. Other items to remain will be marked on the ground.
- C) Work under this section will not be ordered to more than twelve (12) feet slope distance along back slope and eight-foot slope distance along the fill slope.

- D) Work may be performed either by hand or mechanically unless specifically designated by Owner. Self-propelled equipment shall not be allowed on cut and fill slopes or in ditches.
- E) Mechanical brush cutters shall not be operated when there are non-Contractor personnel or occupied vehicles within a hazardous distance of immediate operating area.
- F) Trees within the cutting limits which are over four (4) inches in diameter shall be limbed in lieu of cutting unless designated and marked for removal by Owner.
- G) When trees are limbed, limbs shall be cut within four (4) inches of the trunk.
- H) Side mile work will be ordered in uniform width for the length of the listed segments of roads.
- I) Unless otherwise specified by Owner, work shall commence at the edge of the traveled way and proceed away from the road centerline. For roads without a defined traveled way the starting point for cutting will be marked in the field or defined in the Plan of Work.
- J) Materials resulting from the cutting operation in excess of one (1) foot in length or three (3) inches in diameter shall not be allowed to remain on roadway slopes within the treated area, in ditches, or within water courses.
- K) Measurement for cutting side vegetation by the side mile will be the length of roads or segments ordered and accepted. The length will be determined to the nearest one-tenth (1/10) mile on each side of each road.

13) **CLEARING AND GRUBBING**

- A) All debris, trees, stumps, roots, and other protruding vegetative material within the clearing limits shall be cleared, grubbed, removed, and disposed, except the following:
 - 1) Undisturbed stumps outside of roadway or in embankment areas, provided they do not extend more than twelve (12) inches above the original ground (measured from the uphill side) nor closer than two (2) feet to the finished subgrade or one (1) foot to any slope surface and they do not interfere with the placement or compaction of embankments.
 - 2) Grubbing of pits, channel changes, rock sections, and ditches, below the depth of the proposed excavation.
- B) All roots over two and one half (2 ½) inches in diameter within the roadbed area shall be grubbed to a minimum depth of six (6) inches below subgrade. Roots over two and one half (2 ½) inches in diameter protruding from the excavated slope shall be cut flush with the excavated slope surface.
- C) Trees inside right-of-way clearing shall be felled and bucked to lengths specified by Owner. Contractor shall deck the logs according to 14) I).
- D) The construction of pioneer roads shall be confined to inside the roadway unless otherwise approved by the Owner.
- E) Treatment of construction slash larger than two and one half (2 ½) inches in diameter and three (3) feet in length shall be accomplished by scattering, and stumps over eighteen (18) inches in diameter at the root collar shall be hauled to designated locations. Construction slash shall be scattered outside the clearing limits without damaging trees.

- F) No construction slash shall be deposited in streams or streambeds. Construction slash that interferes with drainage structures shall be removed immediately.
- G) Grubbed stumps over eighteen (18) inches in diameter at the root collar shall be removed from roadway, hauled, and stacked at locations shown on the drawings (when provided) or as designated.

14) DISPOSAL

Dispose of materials using one of the following methods as specified.

- A) Remove from project - Recycle or dispose of material legally off the project.
- B) Burn - Obtain necessary burning permits. Submit a copy of the burning permits before burning begins. Burn using high intensity burning processes that produce few emissions. Provide a watchperson during the burning operations. When burning is complete, extinguish the fire so no smoldering debris remains.
- C) Bury - Bury debris in trenches or pits in approved areas within the right-of-way when approved. Do not bury debris inside roadway prism limits, beneath drainage ditches, or in areas subject to free-flowing water. Place debris in alternating layers of forty-eight (48) inches of debris covered with twenty-four (24) inches of earth material. Distribute stumps, logs, and other large pieces to form a dense mass and minimize air voids. Cover the top layer of buried debris with at least twelve (12) inches of compacted earth. Grade and shape the area. Seed and mulch disposal areas.
- D) Hazardous Material - Dispose of material according to Federal, state, and local regulations.
- E) Windrowing Construction Slash - Place construction slash outside the roadway in neat, compacted windrows approximately parallel to and along the toe line of embankment slopes. Do not permit the top of the windrows to extend above subgrade. Use construction equipment to matt down all material in a windrow to form a compact and uniform pile. Construct breaks of at least fifteen (15) feet at least every two-hundred (200) feet in a windrow. Do not place windrows against trees.
- F) Scattering - Scatter construction slash in designated areas without damaging trees. Limb all logs. Place logs and stumps away from trees, positioned so they will not roll, and are not on top of one another. Limb and scatter other construction slash to reduce slash concentrations. When scattering for erosion control, place construction slash as flat as practicable on the completed slope.
- G) Chipping - Use an approved chipping machine to chip slash longer than three (3) feet. Deposit chips on embankment slopes or outside the roadway to a loose depth less than six (6) inches. Minor amounts of chips or ground woody material may be permitted within the roadway if they are thoroughly mixed with soil and do not form a layer.
- H) Debris Mat - Use tree limbs, tops, cull logs, split stumps, wood chunks, and other debris to form a mat upon which construction equipment is operated. Place stumps upside down and blend stumps into the mat.
- I) Decking - Remove brush from designated log deck areas. Limb and top logs. Merchantable timber not associated with an existing timber sale shall be cut to length meeting the utilization standards set by Owner. Deck logs so that logs are piled parallel to one another; can be removed by standard log loading equipment; will not damage standing trees; will not interfere with drainage, and will not roll. Keep logs in log decks free of brush and soil.
- J) Removal to designated locations - Remove construction slash to designated locations.

- K) Piling - Pile construction slash in designated areas. Place and construct piles so that if the piles are burned, the burning will not damage remaining trees. Keep piles free of dirt from stumps.

15) COMPACTION

Compact using one of the following methods as specified.

- A) Placement Method 1 - Use AASHTO T 27 to determine the quantity of material retained on a No. 4 (4.75-millimeter) sieve. Compact as follows:
- 1) More than 80 percent retained on a No. 4 (4.75-millimeter) sieve. Adjust the moisture content to a level suitable for compaction. Fill the interstices around rock with earth or other fine material as practical. Use compression-type rollers at speeds less than six (6) feet per second and vibratory rollers at speeds less than three (3) feet per second. Compact each layer of material full width with one of the following and until there is no visible evidence of further consolidation:
 - a) Four roller passes of a vibratory roller having a minimum dynamic force of 40,000 pounds impact per vibration and a minimum frequency of 1000 vibrations per minute;
 - b) Eight roller passes of a 20-ton compression-type roller; or
 - c) Eight roller passes of a vibratory roller having a minimum dynamic force of 30,000 pounds impact per vibration and a minimum frequency of 1000 vibrations per minute.

Increase the compactive effort for layers deeper than twelve (12) inches as follows:

 - For each additional six (6) inches or fraction thereof, increase the number of roller passes in subsection a), by four passes; or
 - For each additional six (6) inches or fraction thereof, increase the number of roller passes in subsection b) and c), by eight passes.
 - 2) 50 to 80 percent retained on a No. 4 (4.75-millimeter) sieve. Classify the material according to AASHTO M 145. Adjust the moisture content of material classified A- 1 through A-5 to a moisture content suitable for compaction. Adjust the moisture content of material classified A-6 and A-7 to within 2 percent of the optimum moisture content. Use AASHTO T 99 to determine the optimum moisture content of the portion of the material passing a No. 4 (4.75-millimeter) sieve. Multiply this number by the percentage of material passing a No. 4 (4.75-millimeter) sieve, and add 2 percent to determine the optimum moisture content of the material. Use nonvibratory rollers at speeds less than six (6) feet per second and vibratory rollers at speeds less than three (3) feet per second. Compact each layer of material full width according to subsection 1).

- 3) Less than 50 percent retained on a No. 4 (4.75-millimeter) sieve. Classify the material according to AASHTO M 145. For material classified A-1 or A-2-4, determine the maximum density according to AASHTO T 99, Method C.
Adjust the moisture content of material classified A-1 through A-5 to a moisture content suitable for compaction. Adjust the moisture content of material classified A-6 and A-7 to within 2 percent of the optimum moisture content.
Use compression-type or vibratory rollers. Compact each layer of material full width to at least 95 percent of the maximum density. Determine the in-place density and moisture content according to AASHTO T 310 or other approved test procedures. When required, use AASHTO T 224 to correct for coarse particles.

- B) Placement Method 2 -Adjust the moisture content of the material to a moisture content suitable for compaction. Fill the interstices around rock with earth or other fine material as practical. Operate roller compaction equipment over the full width of each layer until there is no visible evidence of further consolidation or, if when a sheepsfoot roller is used, the roller "walks out" of the layer. Make at least three complete passes. Use compression-type rollers at speeds less than six (6) feet per second and vibratory rollers at speeds less than three (3) feet per second. Ensure rollers meet the following requirements:
- 1) Steel wheeled rollers, other than vibratory, capable of exerting a force of not less than 250 pounds per inch of width of the compression roll or rolls.
 - 2) Vibratory steel wheeled rollers equipped with amplitude and frequency controls with a minimum dynamic force of 30,000 pounds impact per vibration, specifically designed to compact the material on which it is used.
 - 3) Pneumatic-tired rollers with smooth tread tires of equal size that will provide a uniform compacting pressure for the full width of the roller and capable of exerting a ground pressure of at least 80 psi.
 - 4) Sheepsfoot, tamping, or grid rollers capable of exerting a force of 250 pounds per inch of width of roller drum.
- C) Placement Method 3 -Adjust the moisture content of the material to a moisture content suitable for compaction. Fill the interstices around rock with earth or other fine material as practical. Operate hauling and spreading equipment uniformly over the full width of each layer until there is no visible evidence of further consolidation. Make at least three complete passes.
- D) Placement Method 4 -Adjust the moisture content of the material to a moisture content suitable for compaction. Fill the interstices around rock with earth or other fine material as practical. Operate hauling and spreading equipment uniformly over the full width of each layer.
- E) Placement Method 5 - Adjust the moisture content of the material to a moisture content suitable for compaction. Compact the complete surface with a bucket of an excavator larger than 39,000 pounds (18 metric ton) Gross Vehicle Weight using a minimum of three blows. Overlap compaction by ½ width of bucket.
- F) Placement Method 6 -Adjust the moisture content of the material to a moisture content suitable for compaction. Compact using an approved mechanical tamper for a minimum of three complete passes.

When compacting with rollers or hauling and spreading equipment is not practical, use approved mechanical tampers for a minimum of three complete passes.

16) EARTHWORK

This work consists of excavating material and constructing embankments. This work also includes furnishing, hauling, stockpiling, placing, disposing, sloping, shaping, compacting, and finishing earthen and rocky material.

- A) Preparation for Roadway Excavation and Embankment Construction - Clear the area of vegetation and obstructions according to **13**). Road pioneering, slash disposal, and grubbing of stumps may proceed concurrently with excavation and embankment. Maintain drainage during pioneering operations.
- B) Conserved Topsoil - When designated, conserve topsoil from roadway excavation and embankment foundation areas. Stockpile conserved topsoil in low windrows immediately beyond the rounding limits of cut and embankment slopes or in other approved locations. Separate conserved topsoil from other excavated material. When designated, place conserved topsoil on completed slopes as directed by Owner.
- C) Roadway Excavation - Excavate as follows:
- 1) Excavate rock cuts to six (6) inches below subgrade within the roadbed limits. Backfill to subgrade with topping or other suitable material. Compact the material according to **15**).
 - 2) Scarify earth cuts to six (6) inches below subgrade within the roadbed limits. Compact the scarified material according to **15**).
 - 3) Conduct pioneer road excavation and placement operations so material to be treated under **13**) will not be incorporated into the roadway unless specified in the slash treatment method. Maintain drainage during pioneering operations. Remove snow and ice in advance of the work and deposit beyond the roadway limits in a manner that will not waste material or generate sediment. Do not incorporate snow and ice into embankments. Place snow or ice in a manner to prevent resource damage.
 - 4) Drainage feature construction includes all ditches, minor channel changes, drainage dips, catch basins, surface water deflectors, and other minor drainage structures. Compact the material according to **15**). Excavate on a uniform grade between control points.

Do not disturb material and vegetation outside the construction limits. Retrieve material deposited outside the construction limits. Dispose of unsuitable or excess excavation material according to **14**). Replace shortage of suitable material caused by premature disposal of roadway excavation.

Shape to drain and compact the work area to a uniform cross-section at the end of each day's operations.

- D) Subexcavation - Excavate material to the required limits. Dispose of unsuitable material according to **14**). Backfill subexcavated area with suitable material in horizontal layers not exceeding twelve (12) inches in compacted thickness and compact according to **15**). Prevent unsuitable material from mixing with suitable backfill material.
- E) Borrow Excavation - Use suitable roadway excavation in embankment construction. Do not use borrow excavation when it results in excess roadway excavation. Deduct excess borrow excavation from the total borrow excavation quantity.

Obtain borrow source approval from Owner. Develop and restore borrow sources as directed by Owner. Do not excavate beyond the established limits. When applicable, shape the borrow source to permit accurate measurements when excavation is complete.

F) Prepare foundation for embankment construction as follows:

- 1) Embankment over natural ground - Remove topsoil and break up the ground surface to a minimum depth of six (6) inches by plowing or scarifying. Compact the ground surface according to **15**).
- 2) Embankments over an existing asphalt, concrete, or gravel road surface - Scarify gravel roads to a minimum depth of six (6) inches. Scarify or pulverize asphalt and concrete roads to six (6) inches below the pavement. Reduce particles to a maximum size of six (6) inches and produce a uniform material. Compact the surface according to **15**).
- 3) Embankment across ground not capable of supporting equipment - Dump successive loads of embankment material in a uniformly distributed layer to construct the lower portion of the embankment. Limit the layer thickness to the minimum depth necessary to support the equipment.
- 4) Embankment on an existing slope steeper than 1V:3H - Cut horizontal steps in the existing slope to a sufficient width to accommodate placement and compaction operations and equipment. Step the slope as the embankment is placed and compacted in layers. Begin each step at the intersection of the original ground and the vertical cut of the previous step.

G) Embankment Construction - Incorporate only suitable roadway excavation material into the embankment. When the supply of suitable roadway excavation is exhausted, furnish unclassified borrow to complete the embankment. Obtain written approval before beginning construction of embankments over six (6) feet high at subgrade centerline. Construct embankments as follows:

1) General -At the end of each day's operations, shape to drain and compact the embankment surface to a uniform cross-section. Eliminate ruts and low spots that could hold water. During all stages of construction, route and distribute hauling and leveling equipment over the width and length of each layer of material. Compact embankment side slopes with a tamping foot roller, by walking with a dozer, or by over-building the fill and then removing excess material to the final slope line. For slopes 1V:1 $\frac{3}{4}$ H or steeper, compact the slopes as embankment construction progresses.

2) Embankment within the roadway prism - Place embankment material in horizontal layers not exceeding twelve (12) inches in compacted thickness. Incorporate oversize boulders or rock fragments into the twelve (12)-inch layers by reducing them in size or placing them individually as required below. Compact each layer according to **15**) before placing the next layer.

Material composed predominantly of boulders or rock fragments too large for twelve (12) inch layers may be placed in layers up to twenty-four (24) inches thick. Incorporate oversize boulders or rock fragments into the twenty-four (24) inch layer by reducing them in size or placing individual rock fragments and boulders greater than twenty-four (24) inches in diameter as follows:

- a) Reduce rock to less than forty-eight (48) inches in the largest dimension;
- b) Distribute rock within the embankment to prevent nesting;
- c) Place layers of embankment material around each rock to a depth not greater than that permitted above. Fill voids between rocks; and

- d) Compact each layer according to **15)** before placing the next layer.
- 3) Embankment outside of roadway prism - When placing embankment outside the staked roadway prism, place material in horizontal layers not exceeding twenty- four (24) inches in compacted thickness. Compact each layer according to **15)**.
- H) Drainage Features - Slope, grade, and shape all drainage features. Remove projecting roots, stumps, rock, or similar matter. Maintain all drainage features in an open condition and without sticks, and other debris.
- I) Sloping, Shaping, and Finishing - Complete subgrade, slopes, drainage features, culverts, riprap, and other underground minor structures before placing aggregate courses. Slope, shape, and finish as follows:
- 1) Sloping - Leave earth slopes with uniform roughened surfaces, except as described in Stepped slopes with no noticeable break as viewed from the road. Scale rock slopes. If a slide or slipout occurs on a cut or embankment slope, remove or replace the material and repair or restore damage to the work. Bench or key the slope to stabilize the slide. Reshape the cut or embankment slope to an acceptable condition.
 - 2) Stepped slopes - Where required, construct steps on slopes of 1½V:1H to 1V:2H. Construct the steps approximately eighteen (18) inches high. Blend the steps into natural ground at the end of the cut. If the slope contains non-rippable rock outcrops, blend steps into the rock. Remove loose material found in transitional area. Except for removing large rocks that may fall, scaling stepped slopes is not required.
 - 3) Shaping - Shape the subgrade to a smooth surface and to the cross-section required. Shape slopes to gradually transition into slope adjustments without noticeable breaks. At the ends of cuts and at intersections of cuts and embankments, adjust slopes in the horizontal and vertical planes to blend into each other or into the natural ground.
 - 4) Finishing - Ensure that the subgrade is visibly moist during shaping and dressing; smooth and uniform, and shaped to conform to the typical sections. Remove material larger than six (6) inches from the top six (6) inches of the roadbed. Remove unsuitable material from the roadbed, and replace it with suitable material. Scarify to six (6) inches below the bottom of low sections, holes, cracks, or depressions and bring back to grade with suitable material. Maintain proper ditch drainage.
- J) Disposal of Unsuitable or Excess Material - Dispose of unsuitable or excess material at designated sites or according to **14)**. When there is a pay item for waste, shape and compact the waste material in its final location. Do not mix clearing or other material not subject to payment with the waste material.

17) SURFACING

- A) Roads and subgrades shall be uniformly graded, compacted and approved by Owner prior to rocking. Rocking must be done only when weather conditions are acceptable to Owner, and must be suspended when muddy water could enter streams from runoff. For typical cross sections, see **Typical Drawings**.
- B) Furnish hard, durable particles or fragments of crushed stone or gravel conforming to the size and quality requirements for crushed aggregate material normally used locally in the construction and maintenance of highways by Federal or State agencies. Furnish crushed aggregate uniformly graded from coarse to fine and free of organic matter, lumps or balls of clay, and other deleterious material. River gravel shall not be used.

C) The material from which material is produced or manufactured shall meet the following test requirements:

- 1) Hardness - Test Method AASHTO T 96: 35% Maximum
- 2) Durability - Test Method OSHD Standard Passing No.20 Sieve: 30% Maximum Sediment Height: 75mm Maximum
- 3) Sand Equivalent - Test Method: AASHTO T176 - 35 minimum
- 4) Fractured Faces - Test Method: ASTM D5821 - 75% minimum

Sieve Size	% by Mass Passing Designated Sieve (AASHTO T27 and T11)					
	Grading Designation					
	3/8"-0"	3/4"-0"	1 1/2"-0"	2"-0"	2 1/2"-0"	3"-0"
3 1/2"						100
3"					100	
2 1/2"				100	95-100	60-90
2"			100	95-100		
1 1/2"			95-100		55-75	
1"		100				
3/4"		90-100	55-75	55-75		
1/2"	100					
3/8"	90-100	55-75				
1/4"	25-75	40-60	35-50	30-45	30-45	15-35
No. 10	0-35	*	*	*	*	*

*Of the fraction passing 1/4" sieve, 40%-60% shall pass the NO. 10 sieve.

Jaw-Run	Passing	6" sieve	100%
6"-0" Pit-Run	Passing	10" sieve	100%
	Passing	6" sieve	65%

D) Upon request by Owner, Contractor shall have samples of the rock tested for gradation, hardness, and durability at a laboratory acceptable to Owner and supply the test results to Owner for approval prior to rocking.

E) Owner shall be given 24 hours' notice prior to rocking.

F) Contractor shall supply Owner with weight receipts for all rock placed. Weight receipts must be generated from a State of Oregon certified and sealed scale. The gross weight and truck tare weight for each load must be machine printed on the weight ticket along with the truck number, date, and time. The Contractor shall, along with the weight receipts, supply Owner with a summary sheet of rock quantities hauled and on which road the rock was placed.

G) Pit-run surfacing rock shall be spread on roads with a crawler tractor and continuously walked- in. Rock spreading shall begin at nearest point from the rock source and progress toward the end of the project, unless otherwise approved in writing by Owner. Compaction shall be accomplished by using one or more of the approved methods in 15).

- H) Crushed rock shall be uniformly mixed and spread in layers on the approved roadbed. Each layer of crushed rock shall be moistened or dried to a uniform moisture content suitable for maximum compaction and compacted in layers not to exceed six (6) inches in depth. When more than one (1) layer is required, each shall be shaped and compacted before the succeeding layer is placed. Any irregularities or depressions that develop during compaction of the top layer shall be corrected by loosening the material at these places and adding or removing material until the surface is smooth and uniform. Compaction shall be accomplished by using one or more of the approved equipment methods in **15**). Roll from the sides to the center, parallel to the centerline of the road. Compact the material along curbs, headers, walls, and places not accessible to a roller with approved tampers or compactors.

18) ROAD RECONDITIONING

This work consists of reconditioning ditches, shoulders, roadbeds, aggregate surfaces, or the entire road.

For all work performed under this section, Contractor shall maintain the dimensions of the existing template in accordance with the corresponding **Typical Drawings** unless otherwise directed by Owner.

- A) **Ditch Reconditioning** - Remove Slide material, sediment, vegetation, and other debris from existing ditches and culvert inlets/outlets. Reshape ditches and culvert inlets/outlets to achieve positive drainage and uniform ditch width, depth, and grade. Back-slopes shall not be undercut by removal operations.

Dispose of waste at designated sites. Limbs and wood chunks in excess of one (1) foot in length or three (3) inches in diameter shall be removed from ditches and placed outside the roadway.

Suitable material up to four (4) inches in greatest dimension removed from the ditches may be blended into existing native road surface and shoulder. Material from ditch cleaning operations shall not be blended into or bladed across aggregate surfaced roads nor bladed onto or across bituminous surfaced roads. Paved surfaces shall be cleaned of all materials resulting from Contractor's ditch maintenance work. Haul of excess material will be incidental to this item.

Drainage ditch maintenance will be measured to the nearest one-tenth (0.1) mile. Segments of less than one-tenth (0.1) mile will be counted as a full one-tenth (0.1) mile. Lead off ditches are incidental to this item. Lead-off ditches shall be shaped to drain away from the traveled way.

Ditches shall be pulled, and culvert inlets and outlets shall be cleaned and approved by Owner prior to rocking.

Contractor will not disturb any underground utilities marked by signs standard to the industry.

- B) **Surface reconditioning** - The existing traveled way and shoulders, including turnouts unless otherwise ordered, shall be bladed, shaped, and compacted to produce a surface which is uniform, consistent to grade, free draining, and crowned or cross-sloped as indicated by the character of the existing surface unless otherwise directed by Owner.

Repair soft, unstable, or corrugated areas by scarifying to the full aggregate surface depth, or to the bottom of potholes, ruts, and corrugations on native surface roads. Surfacing materials shall be scarified to no less than two (2) inch depth. Scarification shall not go deep enough to cause contamination of the surfacing. Scarification will be considered incidental to blading. Scarified areas shall be compacted according to **15**) prior to placing repair rock.

The Contractor shall apply water during blading when sufficient moisture is not present. Water supply, hauling, and application will be considered incidental to blading.

The Contractor shall establish a blading pattern which provides a uniform driving surface, retains the surfacing on the roadbed and provides a thorough mixing of the materials within the completed surface width. Upon final blading, no disturbed rock shall protrude more than two (2) inches above the adjacent surface unless otherwise provided in the contract. Material not meeting this dimension shall be removed and placed outside the roadbed so as not to obstruct drainage-ways or structures. This material may be scattered off the roadbed if there is free drainage.

Roadbed width in excess of the dimensions shown on the corresponding **Typical Drawings** shall be shaped only as needed to provide drainage away from the traveled way. Established grasses and other vegetation shall not be removed from the excess width except as incidental to providing drainage or unless otherwise provided in the contract.

Surface blading shall be performed during the contract period as ordered by the Owner. Contractor shall commence surface blading within two (2) contract days after receipt of written order unless otherwise stated in the order.

Roadway back-slope shall not be undercut.

Materials resulting from work under this Section shall not be allowed to remain on or in structures, such as bridges, culverts, cattle guards, or drainage dips.

Measurement for blading will be single-lane mile measured along the centerline of the roadway. Measurement will be measured to the nearest one-tenth (0.1) mile.

19) **CULVERT REPLACEMENT**

This work includes removal of existing culverts, bed preparation, and installation and backfill of new culverts of the size and length specified.

- A) Culverts shall be furnished by the Contractor unless otherwise directed by Owner. Culverts shall meet the following specifications:
- 1) Culverts shall be constructed of corrugated aluminized steel type 2, and shall conform to the material and fabricating requirements of AASHTO M274 (aluminized steel type 2 material) ASTM A 929, AASHTO M36 and ASTM A760 (conduit, pipe) **OR**
 - 2) Polyethylene culverts (18" to 48" in diameter), double walled, and meet the requirements of AASHTO M-294-901, Type S. Corrugation types and shapes other than those meeting minimum State Highway requirements, must be approved in writing by OWNER.
 - 3) On new installations of pipe of like material, joining shall be done with bands of like material and corrugations. Manufacturers' instructions shall be followed for prefabricated pipe assembly. The joints between bands and pipe of unlike material shall be coated with an approved bituminous material.
 - 4) Transporting of pipe shall be done carefully. Dragging or allowing free fall from trucks or into trenches shall not be permitted. Damage to coatings shall be repaired before the pipe is covered.
 - 5) Lengths of individual culvert sections shall be not less than ten (10) feet, unless otherwise provided for in special instructions.

- B) Culverts shall be located according to the alignment and grade as shown on the Plan and Profile, **Typical Drawings**, and/or as staked in the field, or as stipulated in special instructions. Culvert grade shall slope away from ditch grade at least 2 percent unless otherwise specified.
- C) Excavation for culverts shall provide at least eighteen (18) inches of width on either side of the of the pipe to accommodate compaction equipment. Culvert excavation shall comply with all OSHA standards for trench safety. The trench bed shall be subexcavated to accommodate culvert bedding, shaped to uniform grade, and compacted for its entire length and width. If necessary, dewatering and removal and replacement of unsuitable material shall be completed prior to compaction and placement of bedding. The foundation and trench walls for all culverts shall be free from logs, stumps, limbs, stones over three (3) inches, and other objects which could damage or distort the pipe during installation or use. Bedrock shall be excavated as required to provide a uniform foundation for the full length of the culvert. The culvert shall be installed to maintain a uniform flow line from inlet to outlet ditch.
- D) Do not place or backfill pipe that meets any of the following conditions until the excavation and foundation have been approved by Owner:
- 1) Embankment height greater than six (6) feet at subgrade centerline.
 - 2) Installation in a stream.
 - 3) Round pipe with a diameter of forty-eight (48) inches or greater.
 - 4) Any box culvert, pipe arch, or structure other than pipe culverts.
- E) Bed pipes with a six (6) inch uncompact layer of well-graded 3/4"-0" or finer crushed aggregate in sufficient length and width to provide a wide band of support evenly over the entire length of the pipe. Culverts less than thirty-six (36) inches in diameter shall be installed with the lock seam on the inlet end placed within 45 degrees of the bottom of the trench.
- F) Backfill using the same material supplied for bedding placed in layers not exceeding six (6) inches loose thickness and compacted under the haunches and alongside the pipe. The material shall be readily compactable and free of frozen lumps, chunks of highly plastic clay or other objectionable material. Rocks larger than three (3) inches in greatest dimension shall not be used within one foot (1) of the pipe. Aggregate backfill material shall be used until backfill is a minimum of twelve (12) inches above the top of the culvert, after which suitable on-site material may be used.
- G) Aggregate bedding and backfill material shall be furnished by the Contractor, placed as specified above, and compacted per **15**). Crushed aggregate shall be incidental to the cost of the culvert.
- H) Minimum cover height shall be twelve (12) inches or manufacturers specified minimum cover, whichever is greater. Add six (6) inches of additional cover for native surface roads. Maximum cover depths shall be per manufacturers specifications.
- I) The ends of each culvert shall be free of logs and debris which would restrict the free flow of water. Culverts in Type F streams must allow free passage of fish as provided in the Oregon Forest Practice Rules. The outlet end of any culvert which would allow water to erode embankment soil into waters of the State shall be provided with a downspout or other approved slope protection device.
- J) Removed culverts become the property of the Contractor. Disposal will not be allowed on the Owners land.

20) CULVERT MAINTENANCE

This work consists of cleaning and reconditioning culverts and other drainage structures

- A) Drainage structures, inlet structures, culverts, catch basins, and outlet channels shall be cleaned when required by the Owner. Catch basins shall be cleaned by reshaping to the dimensions shown in the **Typical Drawings**.
- B) The transition from the ditch line to the catch basin shall be cleaned a distance of ten (10) feet. Outlet channels and lead-off ditches shall be cleaned a distance of six (6) feet. Debris and vegetation shall be removed and placed so as to not enter the channel or ditch or obstruct traffic. Debris and vegetation ordered to be hauled shall be hauled to a designated disposal area in accordance with **14**).
- C) Hydraulic flushing of drainage structures is not allowed unless directed by the Owner.
- D) Cleaning is limited to the first four (4) feet of inlet and outlet determined along the top of structure. Damaged culverts shall be reported to the Owner in writing upon completion of work on each road. Any damage by the Contractor shall be repaired at Contractor's expense.

**Exhibit I
Typical Drawings**

SAMPLE

TYPICAL SECTIONS

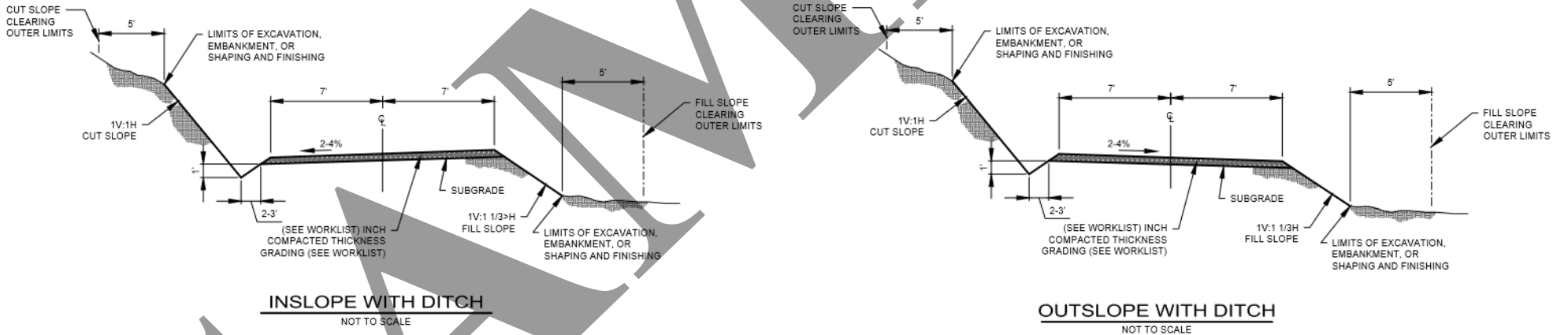
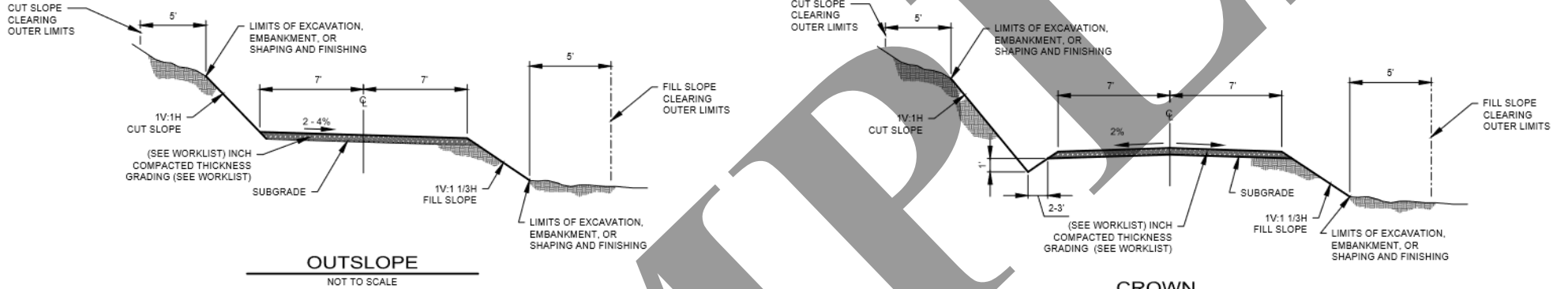

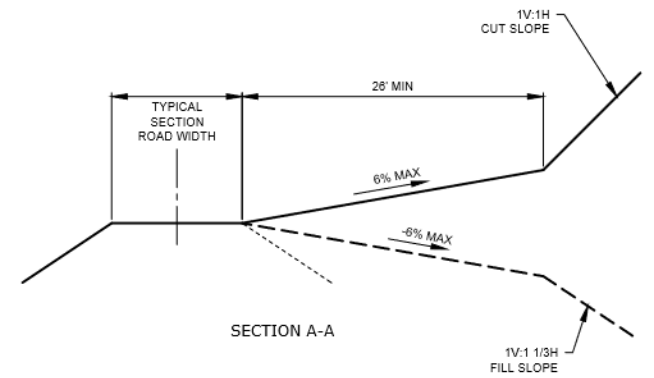
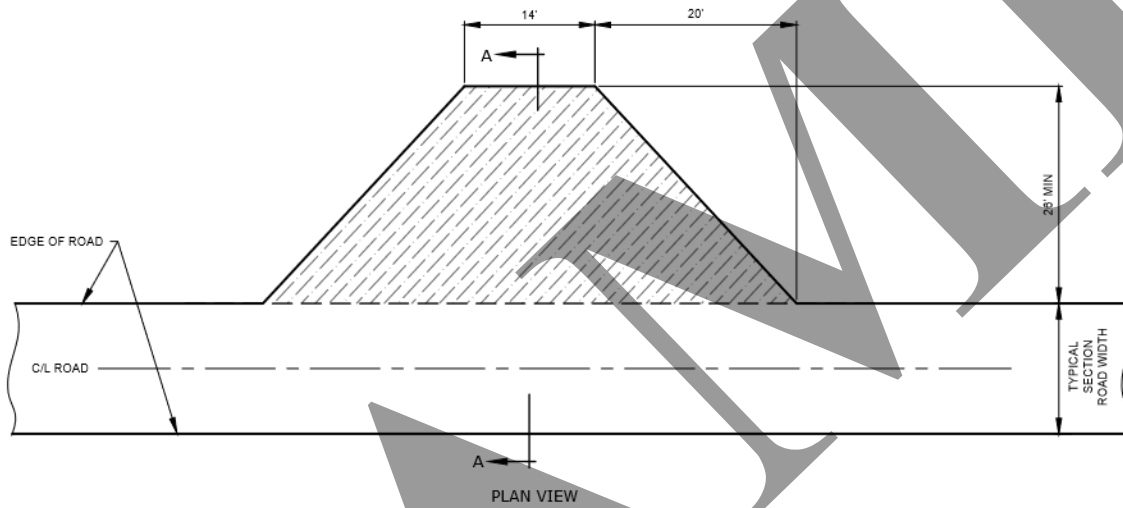
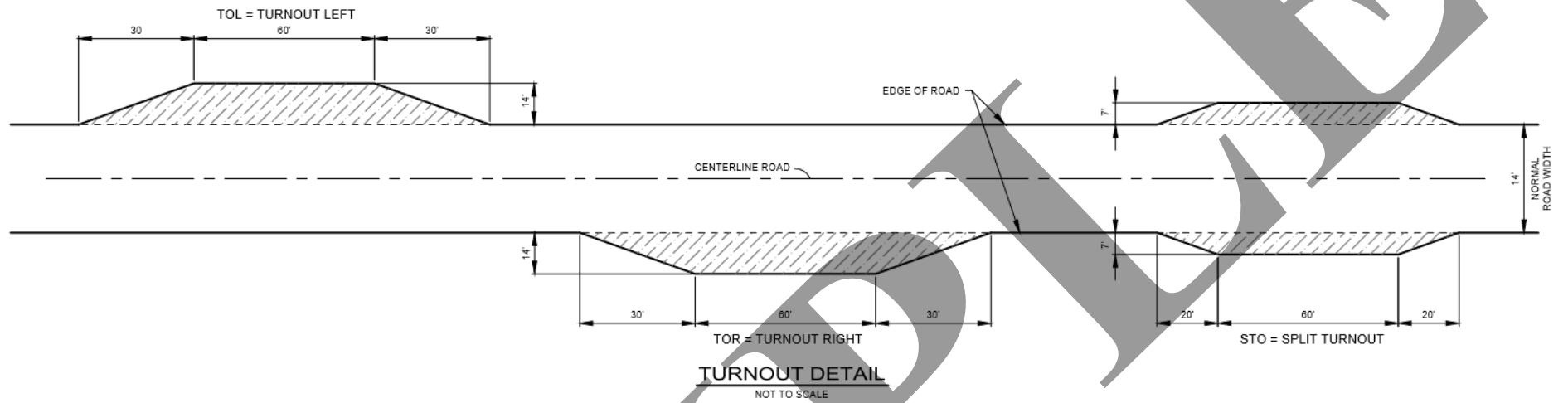

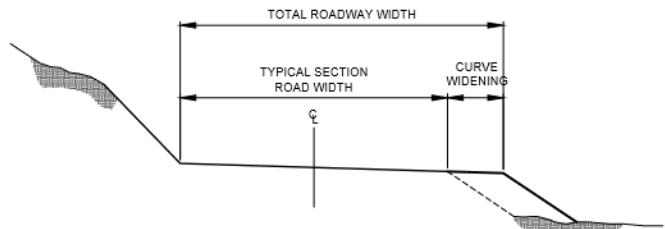

FILL SLOPE CURVE WIDENING
NOT TO SCALE

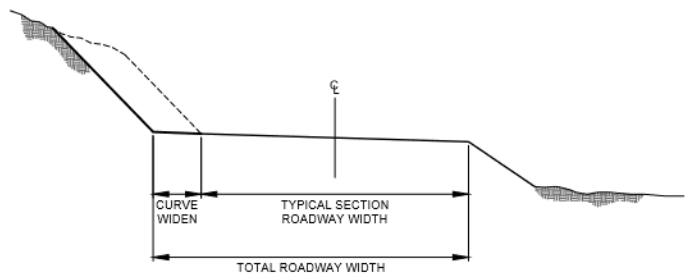

CUT SLOPE CURVE WIDENING
NOT TO SCALE

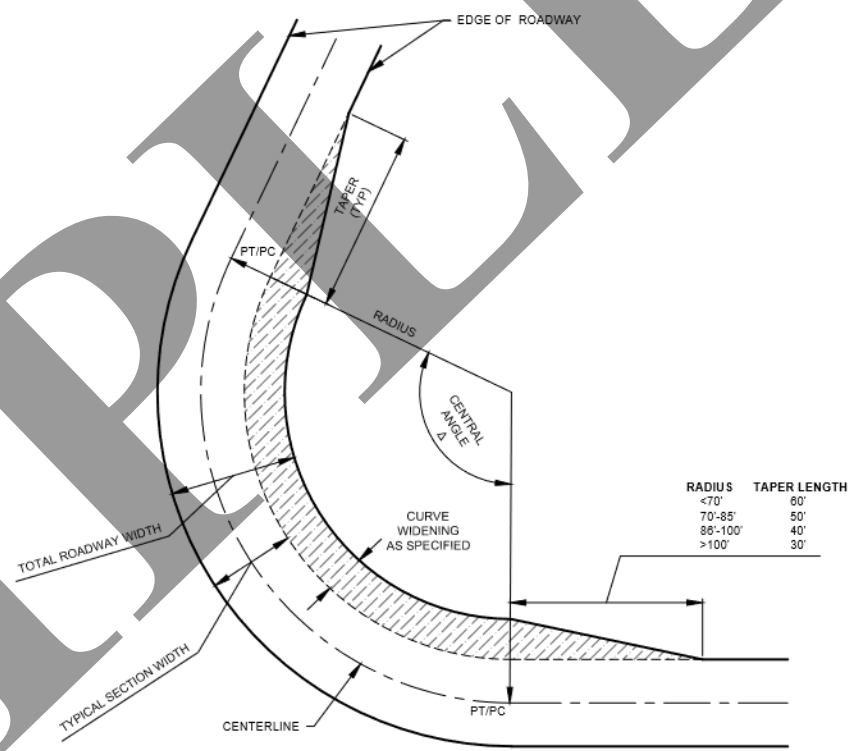

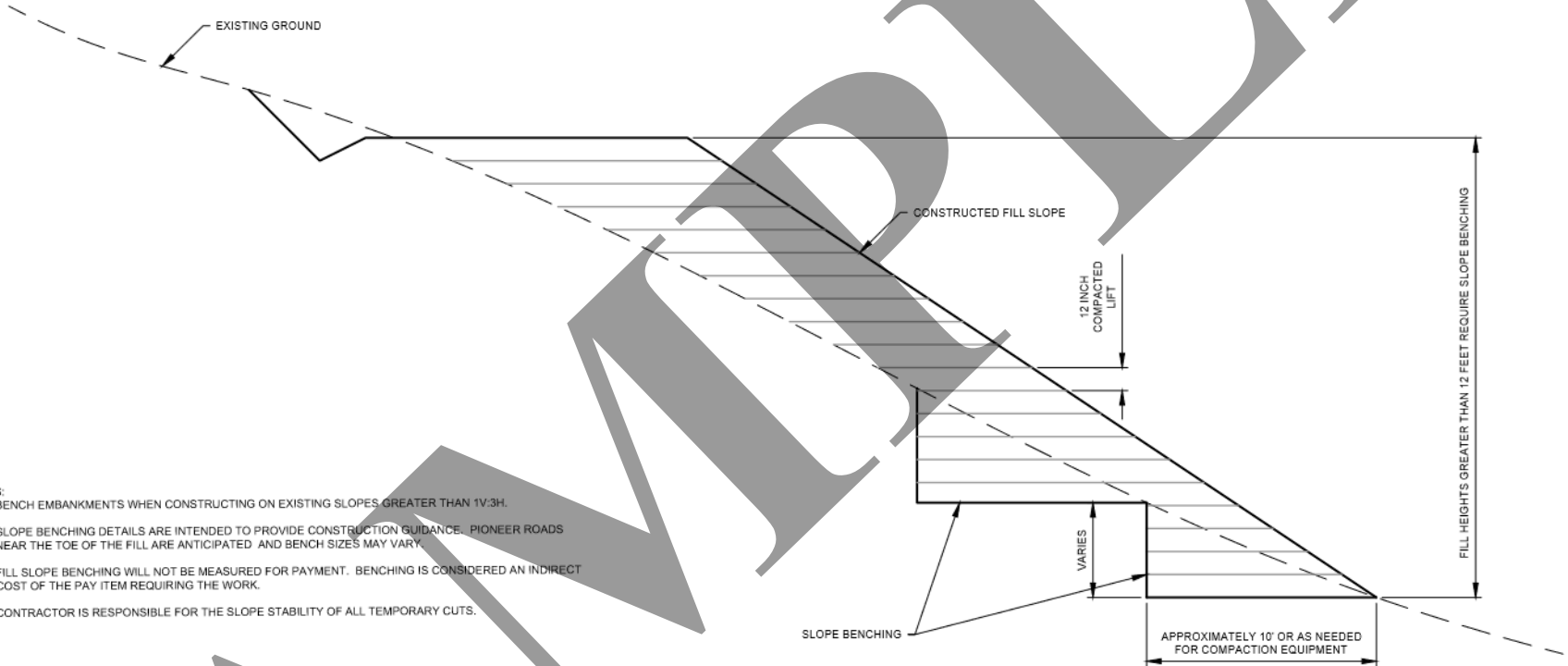

- NOTES:
1. BENCH EMBANKMENTS WHEN CONSTRUCTING ON EXISTING SLOPES GREATER THAN 1V:3H.
 2. SLOPE BENCHING DETAILS ARE INTENDED TO PROVIDE CONSTRUCTION GUIDANCE. PIONEER ROADS NEAR THE TOE OF THE FILL ARE ANTICIPATED AND BENCH SIZES MAY VARY.
 3. FILL SLOPE BENCHING WILL NOT BE MEASURED FOR PAYMENT. BENCHING IS CONSIDERED AN INDIRECT COST OF THE PAY ITEM REQUIRING THE WORK.
 4. CONTRACTOR IS RESPONSIBLE FOR THE SLOPE STABILITY OF ALL TEMPORARY CUTS.

FILL SLOPE BENCHING
NOT TO SCALE

ROAD SUBGRADE REINFORCEMENT - TYPICAL

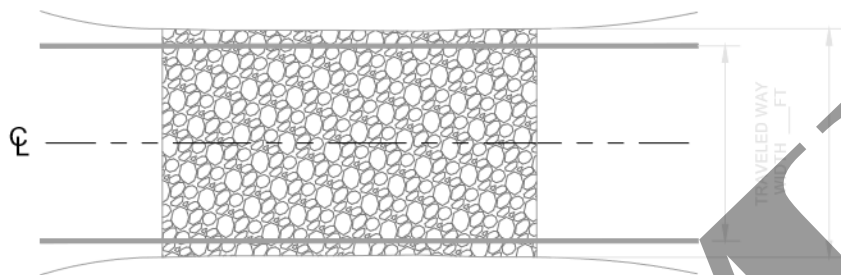

PLAN VIEW

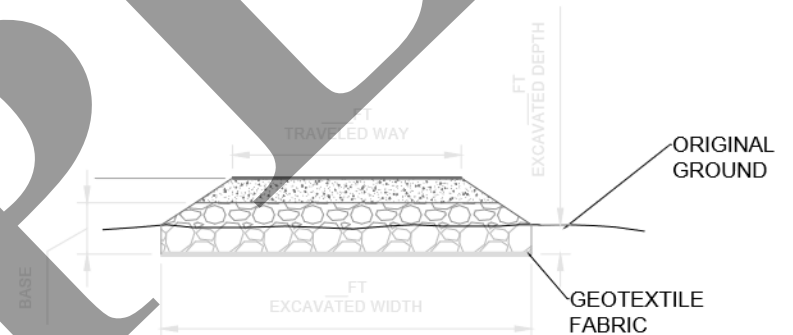

CROSS SECTION VIEW

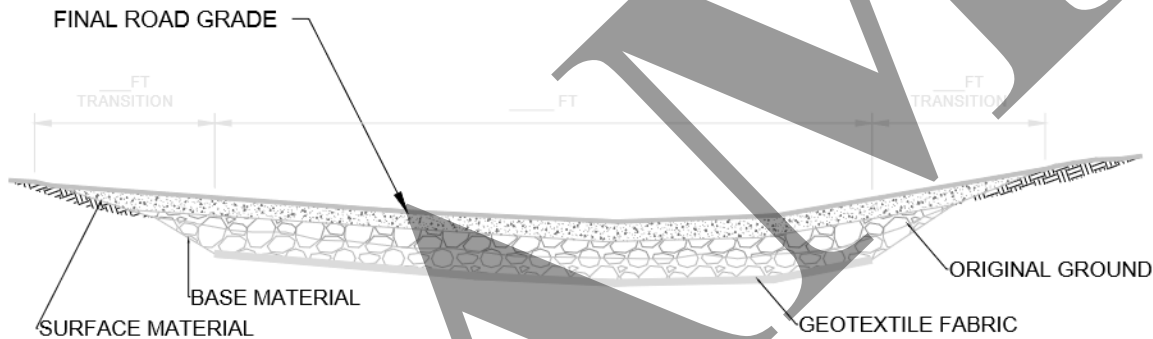

PROFILE VIEW

NOTES:
 DISPOSE OF UNSUITABLE EXCAVATION
 AT LOCATION APPROVED BY OSU.
 SEE WORKLIST FOR DIMENSIONS AND
 MATERIALS

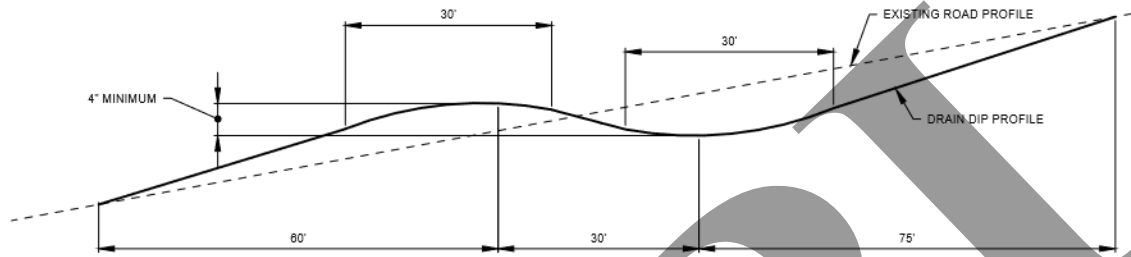

DRAIN DIP - LOG TRUCK
NOT TO SCALE

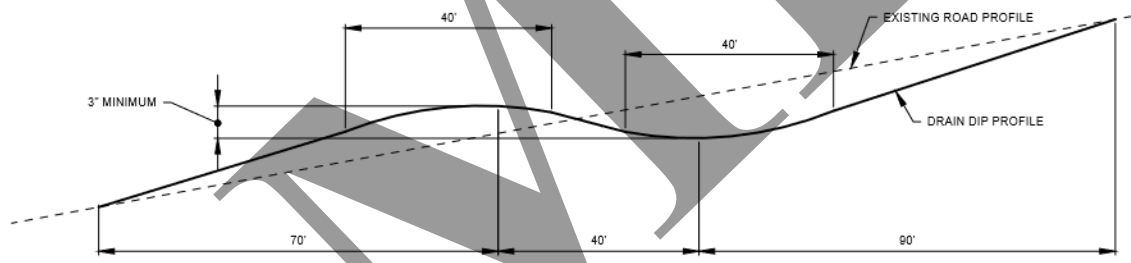

DRAIN DIP - LOWBOY
NOT TO SCALE

- NOTES:
1. CROSS SLOPE OF THE LOW POINT DRAINLINE SHALL BE 5%.
 2. SKEW OF DRAINLINE SHALL BE 0-25 DEGREES.
 3. UNLESS OTHERWISE SPECIFIED IN THE WORKLIST DO NOT INTERCEPT THE ROADWAY DITCH.

CLEARING DETAILS
NOT TO SCALE

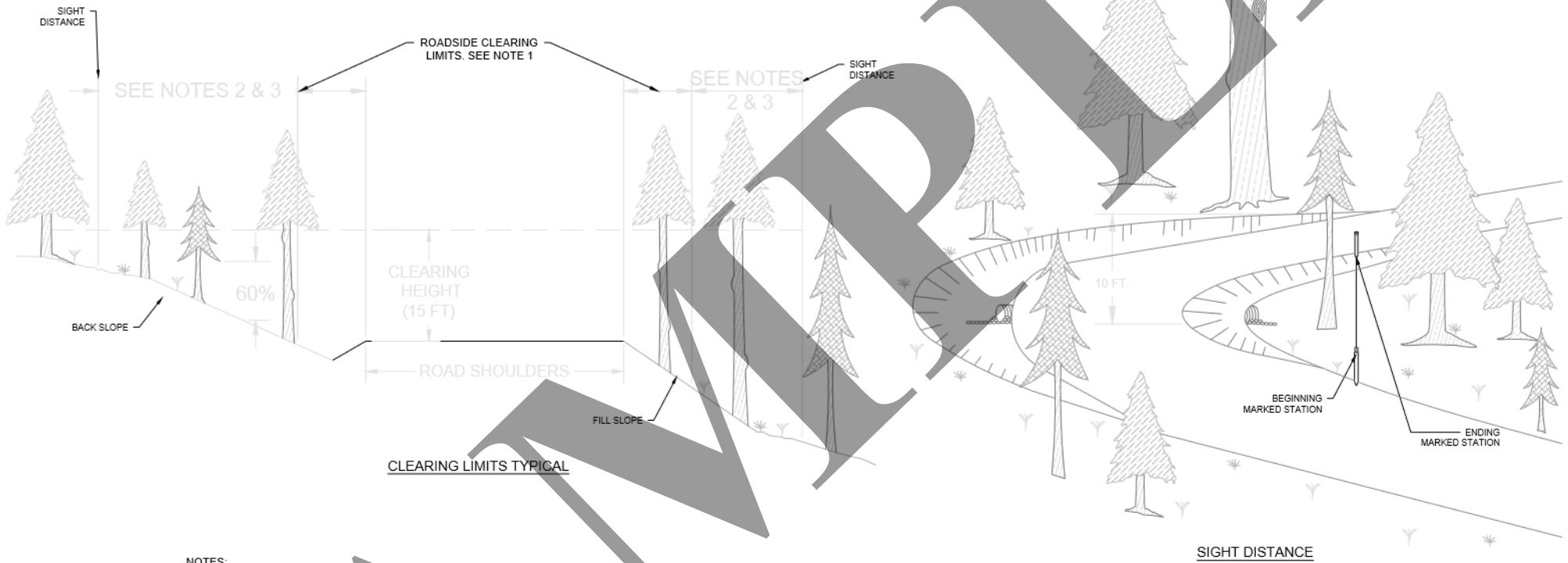

NOTES:

1. ALL CONIFERS, HARDWOODS AND BRUSH WITHIN 5 FEET OF THE SHOULDERS OF THE ROAD OR THE BOTTOM OF THE DITCH SHALL BE REMOVED.
2. THE AREA OF SIGHT DISTANCE CLEARING WILL BE FROM THE ROADSIDE CLEARING LIMIT TO A LINE OF SIGHT BETWEEN THE BEGINNING AND ENDING STATIONS MARKED ON THE GROUND. CONIFERS WITHIN THIS AREA SHALL BE THINNED TO APPROXIMATELY A 2 FOOT TRUNK SPACING, EXCEPT WHERE MARKED WITH PAINT OR FLAGGING FOR REMOVAL TO AN ALTERNATE SPACING. ALL HARDWOODS AND BRUSH WITHIN THESE LIMITS SHALL BE REMOVED.
3. BRANCHES ON REMAINING CONIFERS SHALL BE TRIMMED FROM GROUND LEVEL TO A CLEARING HEIGHT LIMIT 10 FEET ABOVE THE ROADBED OR TO A LIMIT OF 60% OF THE TREE'S HEIGHT, WHICHEVER IS LESS. LIMBS OF VEGETATION SHALL BE CUT SO AS NOT TO PROTRUDE WITHIN THE CLEARING (ROADSIDE AND HEIGHT) LIMITS.

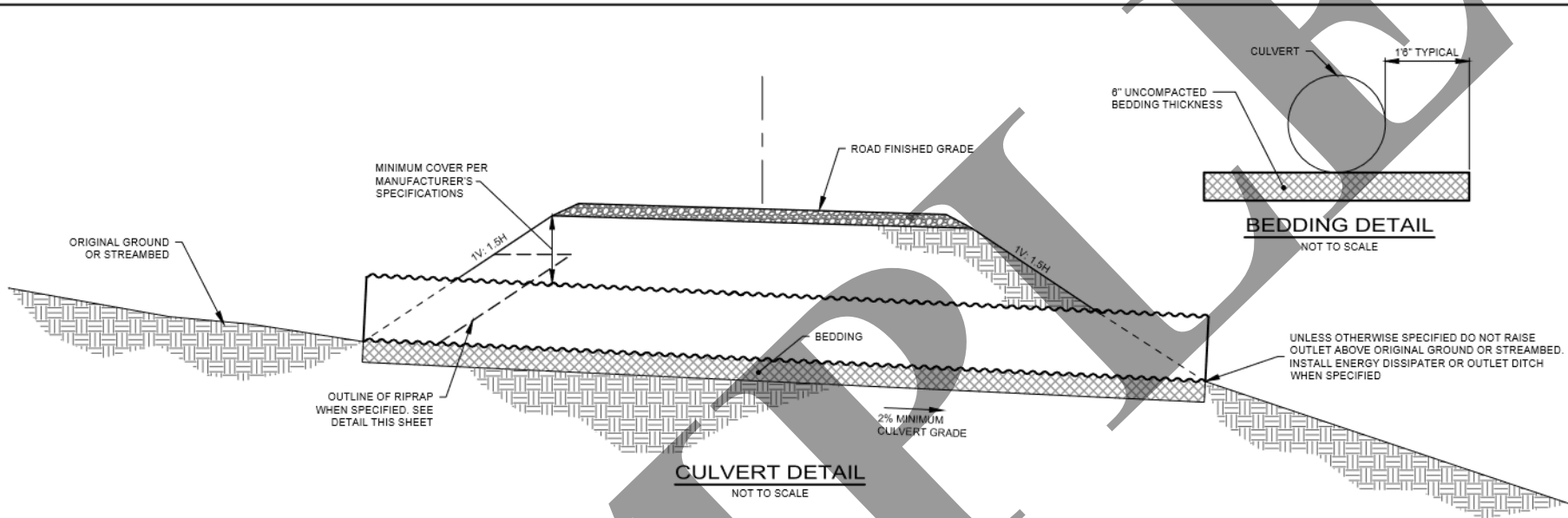

UNLESS OTHERWISE SPECIFIED DO NOT RAISE
OUTLET ABOVE ORIGINAL GROUND OR STREAMBED.
INSTALL ENERGY DISSIPATER OR OUTLET DITCH
WHEN SPECIFIED

CULVERT DETAIL
NOT TO SCALE

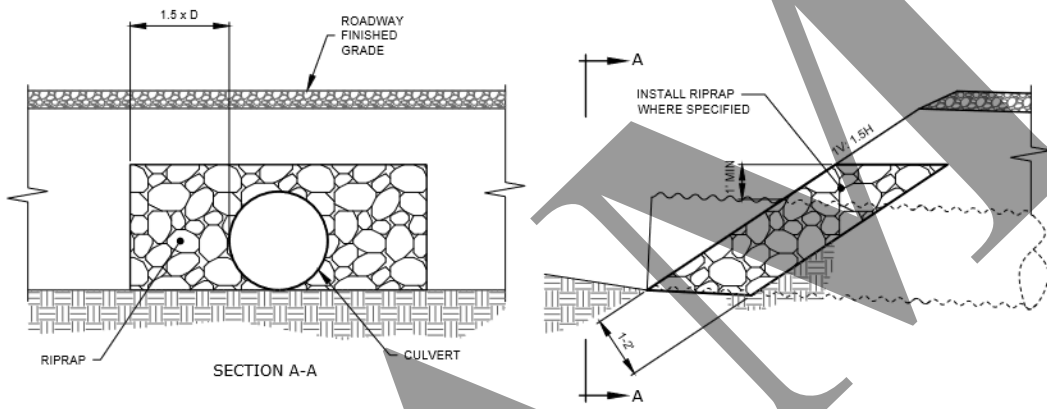

RIPRAP DETAIL
NOT TO SCALE

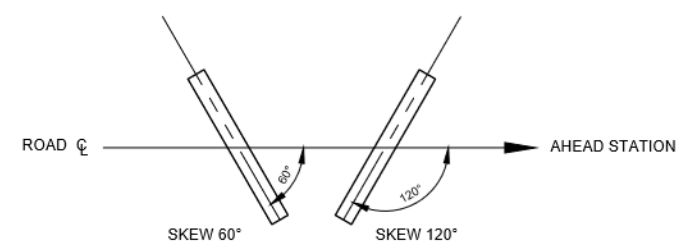

SKEW DIAGRAM
NOT TO SCALE

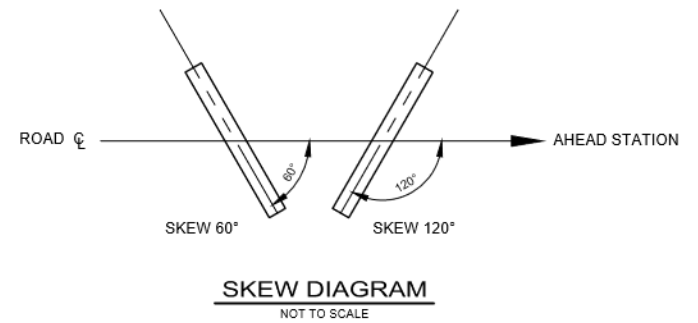
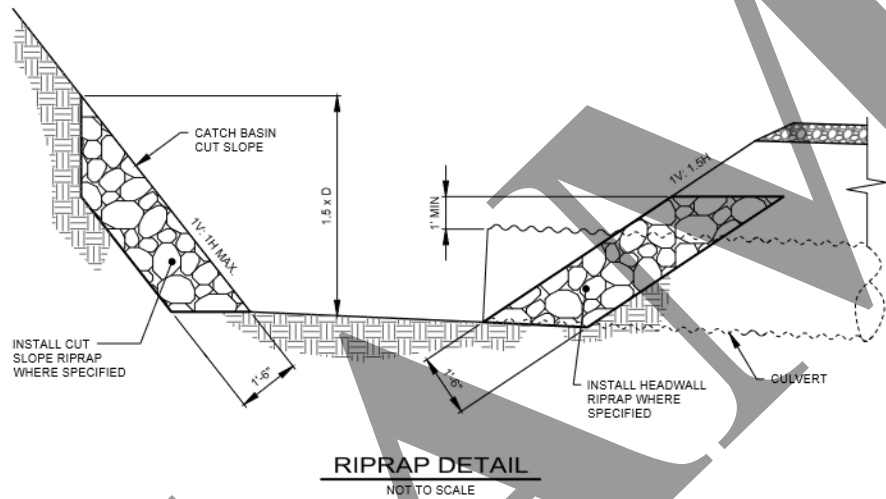
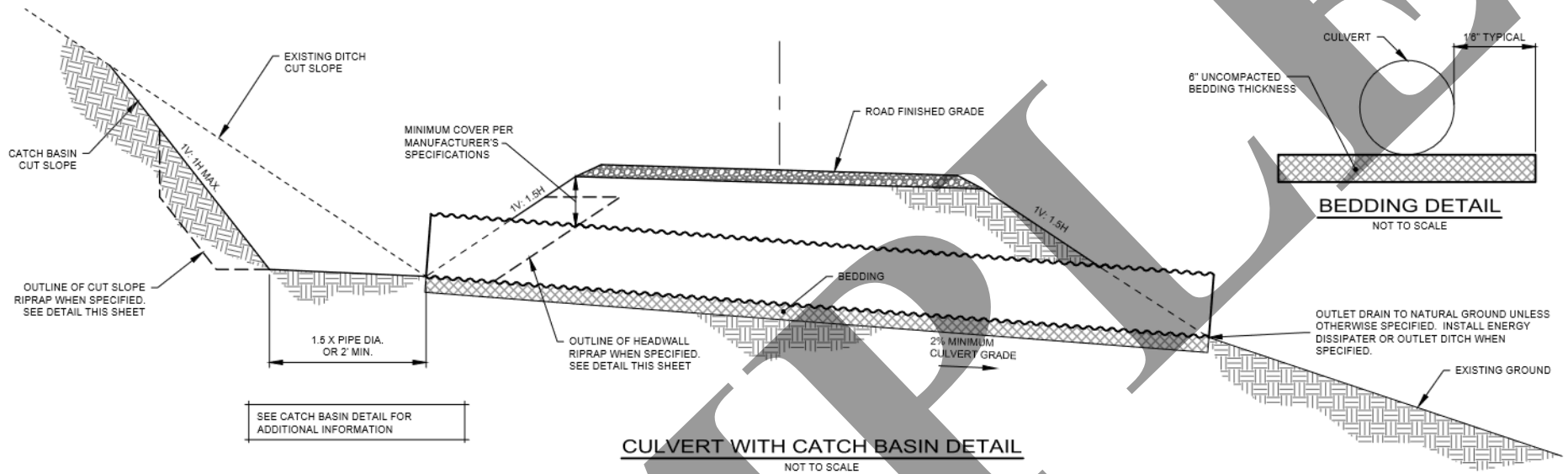

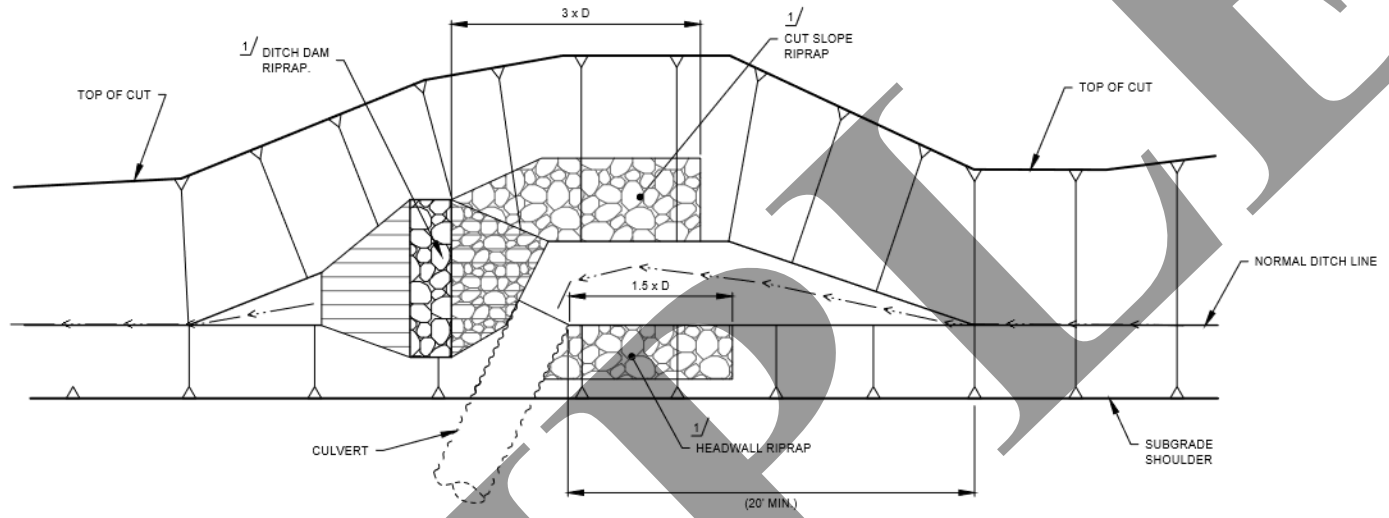

PLAN VIEW
CATCH BASIN DETAIL
 NOT TO SCALE

1/4 INSTALL RIPRAP WHEN SPECIFIED

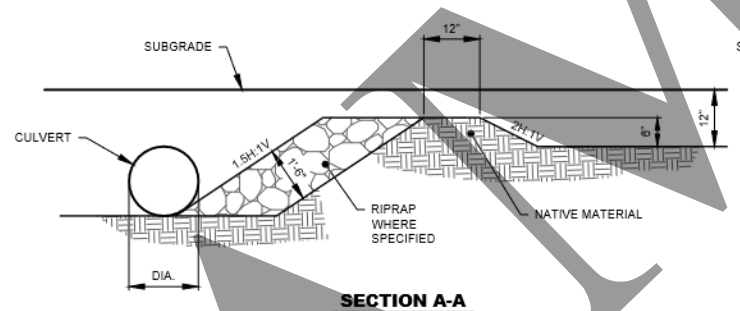

SECTION A-A

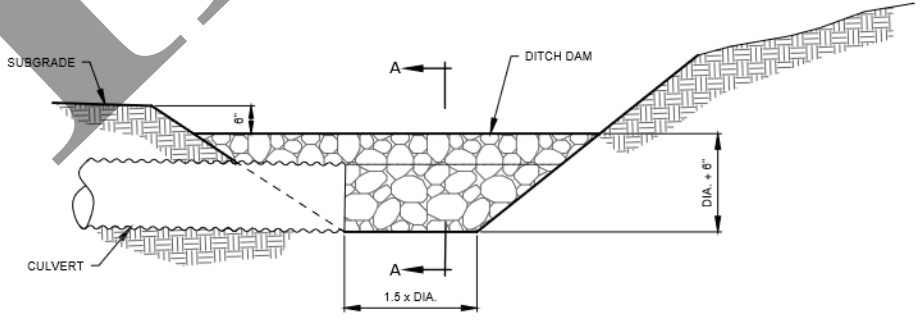

CATCH BASIN ELEVATION

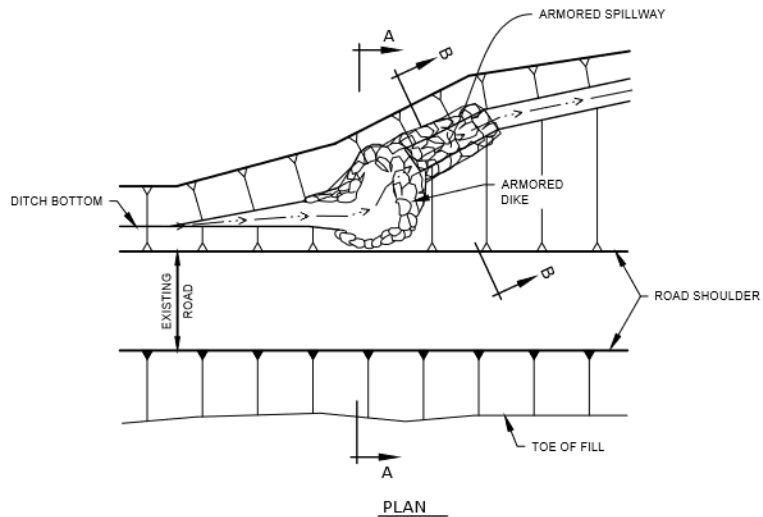

PLAN

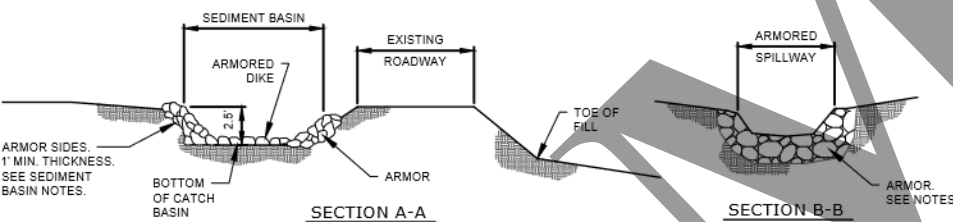

SECTION A-A

SECTION B-B

SEDIMENT BASIN

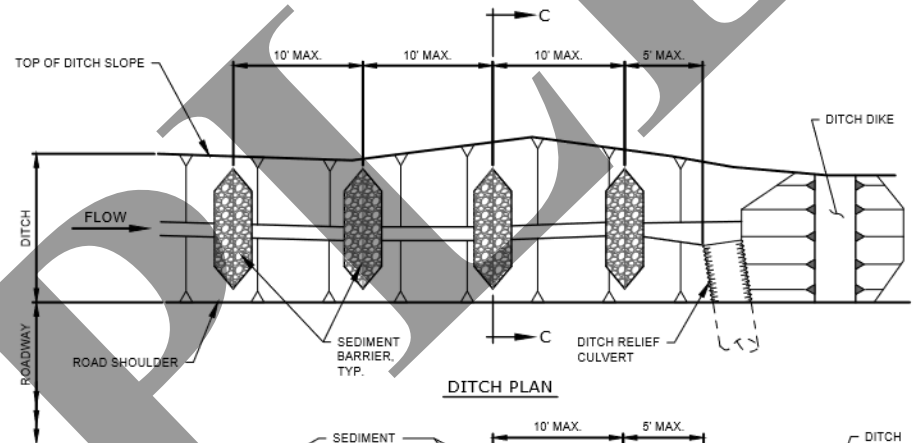

DITCH PLAN

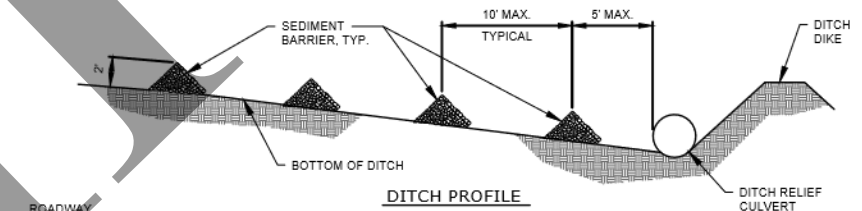

DITCH PROFILE

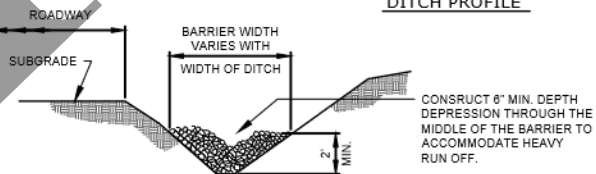

SECTION C-C

SEDIMENT TRAPS

SEDIMENT TRAP NOTES:

- 1.) CONSTRUCT SEDIMENT BARRIERS USING ROCK THAT RANGES IN SIZE FROM 2" MINIMUM TO 5" MAXIMUM.
- 2.) DO NOT CONSTRUCT BARRIERS HIGHER THAN 6" BELOW THE ADJACENT SUBGRADE ELEVATION.

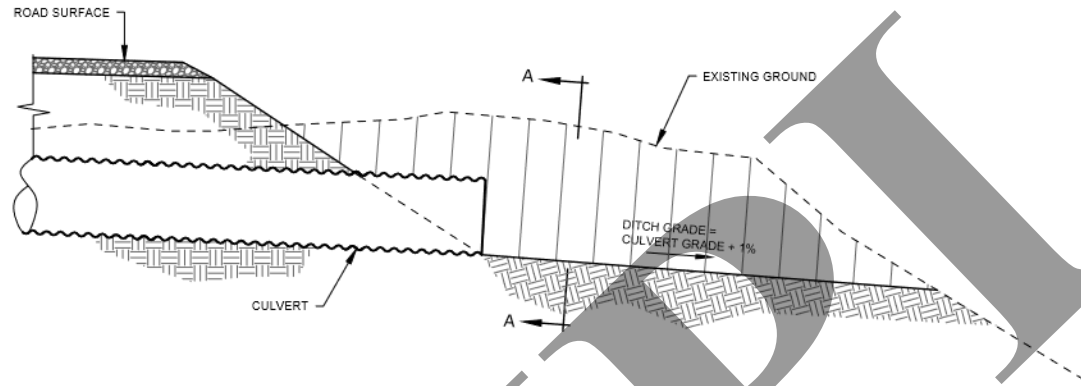

SECTION ALONG CENTERLINE CULVERT/OUTLET DITCH

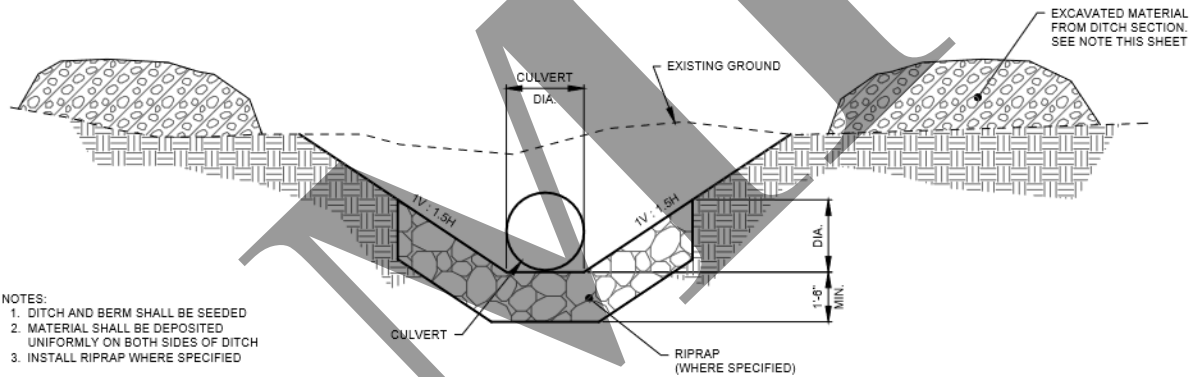

- NOTES:
 1. DITCH AND BERM SHALL BE SEEDED
 2. MATERIAL SHALL BE DEPOSITED
 UNIFORMLY ON BOTH SIDES OF DITCH
 3. INSTALL RIPRAP WHERE SPECIFIED

SECTION A-A

OUTLET DITCH

NOT TO SCALE

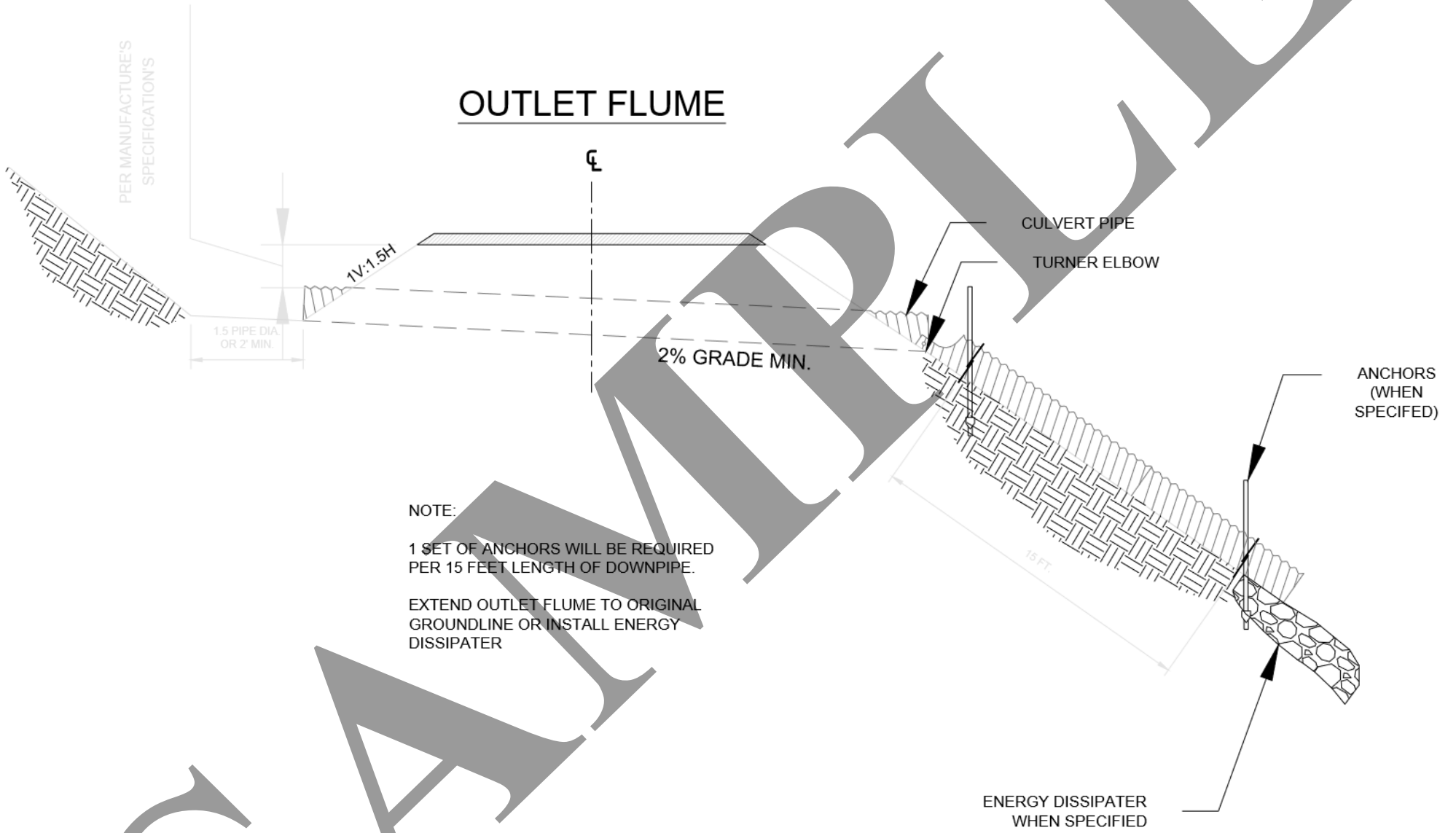

ENERGY DISSIPATOR

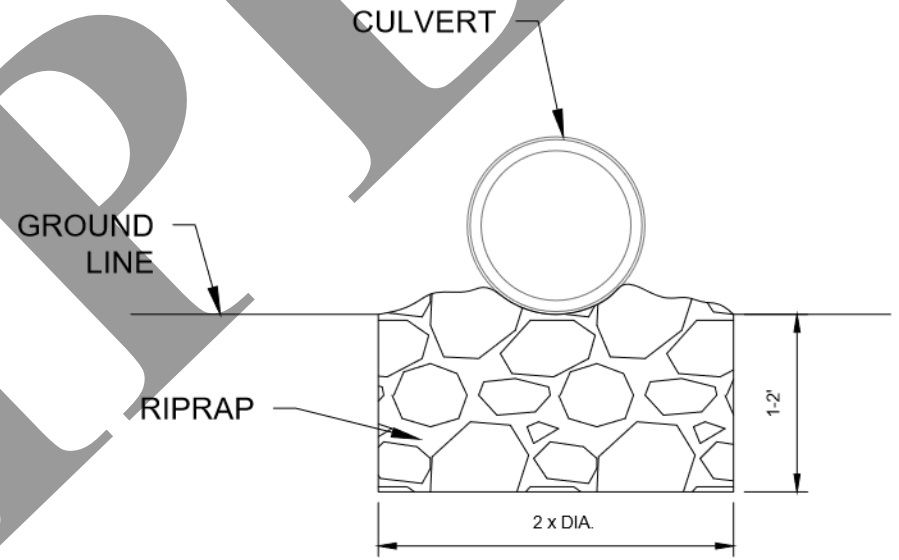
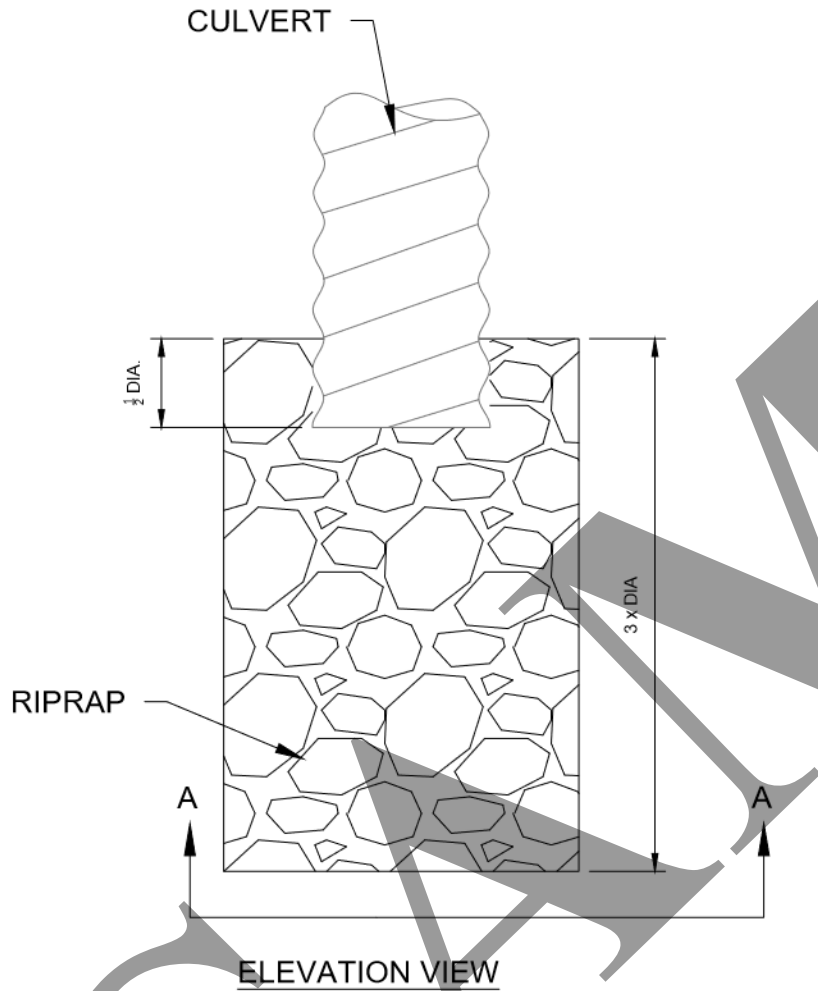

NOTE:
APRON SURFACE SHALL BE LEFT WITH PROTRUDING
RIPRAP FOR VELOCITY BREAK.

SECTION VIEW 'A-A'

ROAD DECOMMISSIONING CULVERT REMOVAL-TYPICAL

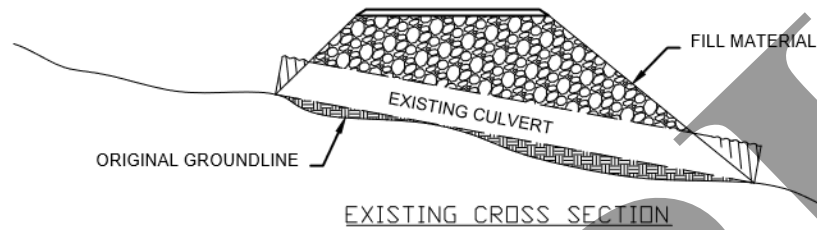

NOTES:

1. EXCAVATE TO ORIGINAL GROUND LINE, REMOVING THE CULVERT AND ALL FILL MATERIAL WITHIN DRAINAGE LIMITS.
2. EXCAVATED CHANNEL MAY REQUIRE ROCK ARMOR, AS DIRECTED BY DSU.
3. IF OLD CLEARING SLASH IS FOUND, SCATTER ON FINISH SLOPE AS DIRECTED BY DSU.

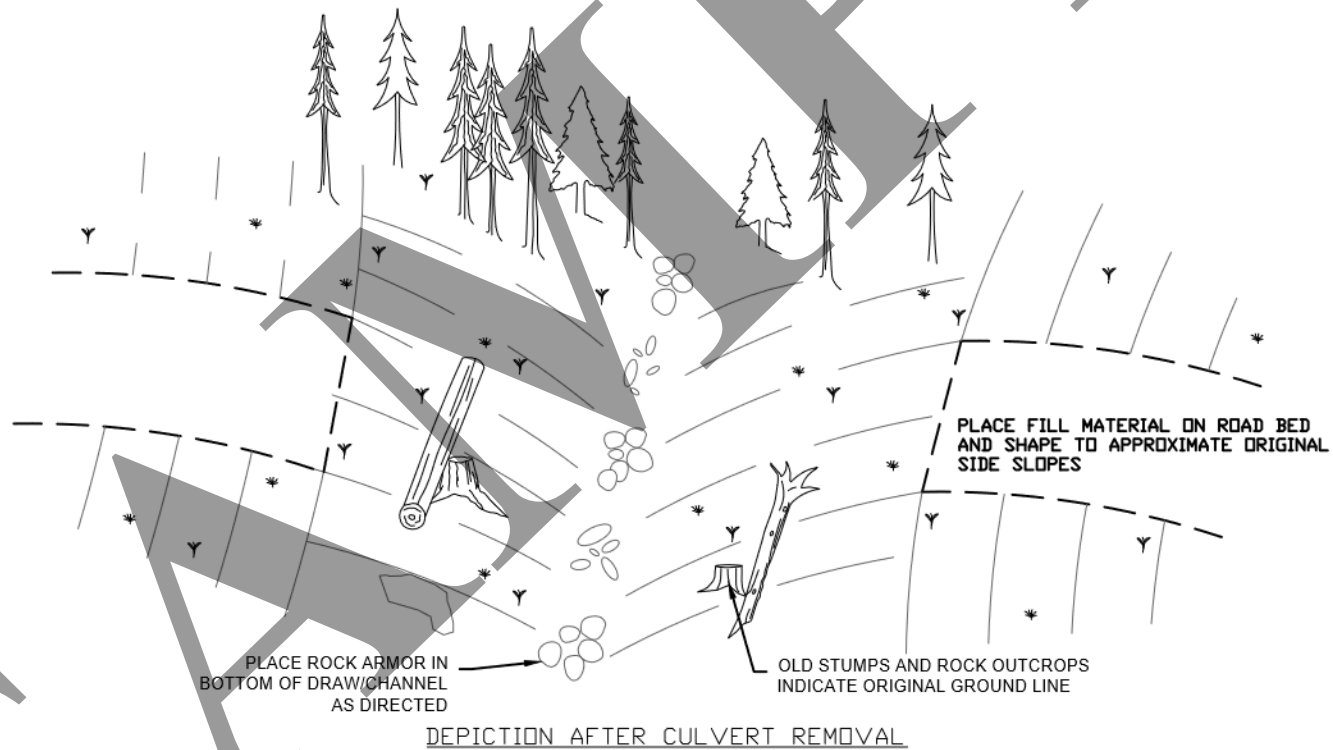

OREGON STATE UNIVERSITY GENERAL CONDITIONS MASTER CONTRACT FOR CONSTRUCTION RELATED SERVICES

July 1, 2019

INSTRUCTIONS: The attached **Oregon State University, Master Contract for Construction Related Services General Conditions ("General Conditions")** apply to all designated master contracts. Changes to the General Conditions (including any additions, deletions or substitutions) should only be made by attaching Supplemental General Conditions. The text of these General Conditions should not otherwise be altered.

TABLE OF SECTIONS

SECTION A **GENERAL PROVISIONS**

- A.1 DEFINITION OF TERMS
- A.2 SCOPE OF WORK
- A.3 INTERPRETATION OF CONTRACT DOCUMENTS
- A.4 EXAMINATION OF PLANS, SPECIFICATIONS, AND SITE
- A.5 INDEPENDENT CONTRACTOR STATUS
- A.6 RETIREMENT SYSTEM STATUS AND TAXES
- A.7 GOVERNMENT EMPLOYMENT STATUS

SECTION B **ADMINISTRATION OF THE CONTRACT**

- B.1 OWNER'S ADMINISTRATION OF THE CONTRACT
- B.2 CONTRACTOR'S MEANS AND METHODS
- B.3 MATERIALS AND WORKMANSHIP
- B.4 PERMITS
- B.5 COMPLIANCE WITH GOVERNMENT REGULATIONS
- B.6 SUPERINTENDENCE
- B.7 INSPECTION
- B.8 SEVERABILITY
- B.9 ACCESS TO RECORDS
- B.10 WAIVER
- B.11 SUBCONTRACTS AND ASSIGNMENT
- B.12 SUCCESSORS IN INTEREST
- B.13 OWNER'S RIGHT TO DO WORK
- B.14 OTHER CONTRACTS
- B.15 GOVERNING LAW
- B.16 LITIGATION
- B.17 ALLOWANCES
- B.18 SUBMITTALS, SHOP DRAWINGS, PRODUCT DATA, AND SAMPLES
- B.19 SUBSTITUTIONS
- B.20 USE OF PLANS AND SPECIFICATIONS
- B.21 FUNDS AVAILABLE AND AUTHORIZED
- B.22 NO THIRD PARTY BENEFICIARIES

SECTION C **WAGES AND LABOR**

- C.1 MINIMUM WAGES RATES ON PUBLIC WORKS
- C.2 PAYROLL CERTIFICATION AND FEE REQUIREMENTS
- C.3 PROMPT PAYMENT AND CONTRACT CONDITIONS
- C.4 PAYMENT FOR MEDICAL CARE
- C.5 HOURS OF LABOR

SECTION D **CHANGES IN THE WORK**

- D.1 CHANGES IN THE WORK
- D.2 DELAYS
- D.3 CLAIMS REVIEW PROCESS

SECTION E
PAYMENTS

- E.1 SCHEDULE OF VALUES
- E.2 APPLICATIONS FOR PAYMENT
- E.3 PAYROLL CERTIFICATION REQUIREMENT
- E.4 DUAL PAYMENT SOURCES
- E.5 RETAINAGE
- E.6 FINAL PAYMENT

SECTION F
JOB SITE CONDITIONS

- F.1 USE OF PREMISES
- F.2 PROTECTION OF WORKERS, PROPERTY, AND THE PUBLIC
- F.3 CUTTING AND PATCHING
- F.4 CLEANING UP
- F.5 ENVIRONMENTAL CONTAMINATION
- F.6 ENVIRONMENTAL CLEAN-UP
- F.7 FORCE MAJEURE

SECTION G
INDEMNITY, BONDING AND INSURANCE

- G.1 RESPONSIBILITY FOR DAMAGES/INDEMNITY
- G.2 PERFORMANCE AND PAYMENT SECURITY, PUBLIC WORKS BOND
- G.3 INSURANCE

SECTION H
SCHEDULE OF WORK

- H.1 CONTRACT PERIOD
- H.2 SCHEDULE
- H.3 PARTIAL OCCUPANCY OR USE

SECTION I
CORRECTION OF WORK

- I.1 CORRECTIONS OF WORK BEFORE FINAL PAYMENT
- I.2 WARRANTY WORK

SECTION J
SUSPENSION AND/OR TERMINATION OF THE WORK

- J.1 OWNER'S RIGHT TO SUSPEND THE WORK
- J.2 CONTRACTOR'S RESPONSIBILITIES
- J.3 COMPENSATION FOR SUSPENSION
- J.4 OWNER'S RIGHT TO TERMINATE CONTRACT
- J.5 TERMINATION FOR CONVENIENCE
- J.6 ACTION UPON TERMINATION

SECTION K
CONTRACT CLOSE-OUT

- K.1 RECORD DOCUMENTS
- K.2 OPERATION AND MAINTENANCE MANUALS
- K.3 COMPLETION NOTICES
- K.4 TRAINING
- K.5 EXTRA MATERIALS
- K.6 ENVIRONMENTAL CLEAN-UP
- K.7 CERTIFICATE OF OCCUPANCY
- K.8 OTHER CONTRACTOR RESPONSIBILITIES
- K.9 SURVIVAL

OREGON STATE UNIVERSITY
GENERAL CONDITIONS FOR MASTER CONTRACT FOR CONSTRUCTION RELATED SERVICES
(“General Conditions”)

SECTION A
GENERAL PROVISIONS

A.1 DEFINITION OF TERMS

In the Contract Documents, the following terms shall be as defined below:

AMENDMENT, means a writing which, when fully executed by the Parties to this Contract, constitutes a change to a Contract Document. Amendments to Supplements (hereinafter a “Supplement Amendment”) shall be issued in accordance with the changes provisions of Section D and, if applicable, establish a Contract Price or Contract Time adjustment.

APPLICABLE LAWS, means federal, state and local laws, codes, rules, regulations and ordinances applicable to the Work and to the Contract.

ARCHITECT/ENGINEER, means the Person appointed by the Owner to make drawings and specifications and, to provide contract administration of the Work contemplated by the Contract to the extent provided herein or by supplemental instruction of Owner (under which Owner may delegate responsibilities to the Architect/Engineer), in accordance with ORS Chapter 671 (Architects) or ORS Chapter 672 (Engineers) and administrative rules adopted thereunder.

CHANGE ORDER, means a written order issued by the Owner to be later included as an Amendment. A Change Order shall not be effective until codified as an Amendment.

CLAIM, means a demand by Contractor pursuant to Section D.3 for review of the denial of Contractor’s initial request for an adjustment of Contract terms, payment of money, extension of Contract Time or other relief, submitted in accordance with the requirements and within the time limits established for review of Claims in these General Conditions.

CONSTRUCTION CHANGE DIRECTIVE, means a written order by the Owner to the Contractor requiring a change in the Work within the general scope of the Contract Documents, issued under the changes provisions of Section D.

CONSTRUCTION SCHEDULE, means the schedule prepared by the Contractor in CPM format and approved by the Owner, and all adjustments thereto approved by the Owner, that describes sequence and timing of the Work.

CONTRACT, means the written agreement between the Owner and the Contractor comprised of the Contract Documents which describe the Work to be done and the obligations between the parties.

CONTRACT DOCUMENTS, means the Solicitation Document General Conditions, Supplemental General Conditions if any, Purchase Orders, the accepted Offer, Plans, Specifications, Change Orders Construction Change Directives, Solicitation Document and addenda thereto, Instructions to Offerors, and Supplemental Instructions to Offerors, and any other Amendment, the Construction Schedule prepared and approved in accordance with the Construction Documents, and all other required Submittals.

CONTRACT PERIOD, as set forth in the Contract Documents, means the total period of time beginning with the full execution of a Supplement and, if applicable, the issuance of a Notice to Proceed and concluding upon Final Completion.

CONTRACT PRICE, means the total of the awarded Offer amount, as increased or decreased by the price of approved alternates, as indicated in the Contract Documents.

CONTRACT TIME, means any incremental period of time allowed under the Contract to complete any portion of the Work as reflected in the project schedule.

CONTRACTOR, means the Person awarded the Contract for the Work contemplated.

CPM, means a critical path method format to be used for the Construction Schedule.

DAYS, are calendar days, including weekdays, weekends and holidays, unless otherwise specified.

DIRECT COSTS, means, unless otherwise provided in the Contract Documents, the cost of materials, including sales tax, cost of delivery; cost of labor, including social security, Medicare and unemployment insurance, and fringe benefits required by agreement or custom; worker’s compensation insurance; project specific insurance (including, without limitation, Builder’s Risk Insurance and Builder’s Risk Installation Floater); bond premiums, rental cost of equipment, and machinery required for execution of the Work; and the additional costs of field personnel directly attributable to the Work.

FINAL COMPLETION, means the final completion of all requirements under the Contract, including Contract Closeout as described in Section K but excluding Warranty Work as described in Section I.2, and the final payment and release of all retainage, if any, released.

FINAL PAYMENT, means the last payment to the Contractor, including retainage, in connection with the Work.

FORCE MAJEURE, means an act, event or occurrence caused by fire, riot, war, acts of God, nature, sovereign, or public enemy, strikes, freight embargoes or any other act, event or occurrence that is beyond the control of the party to this Contract who is asserting Force Majeure.

MWESB REPORT, means an accurate report by the Contractor to the Owner identifying all Minority, Women and Emerging Small Business (MWESB) enterprises, as those terms are defined in ORS 200.005, receiving contracts throughout the course of the Work. An initial MWESB report is required (see Section E.2.9) and MWESB Reports are required annually (see Section E.2.9) and as a condition of final payment (see Section K.1). The initial report shall include the total number of contracts and subcontracts awarded to MWESB enterprises and the dollar value of their respective contracts and subcontracts. The annual reports shall include the total number of contracts and subcontracts awarded to MWESB enterprises, the dollar value of each, and the expenditure toward each contract and subcontract during the previous twelve (12) months. The final report shall include the total number of contracts and subcontracts awarded to MWESB enterprises and the dollar value of their respective contracts and subcontracts including all Supplements and Amendments incorporated during the course of the project. The reports shall only include enterprises certified with the State of Oregon as MWESB enterprises and shall include individual identification of each enterprise as a Minority business enterprise, a Women business enterprise, and/or an Emerging Small Business Enterprise, as applicable.

NOTICE TO PROCEED, means the official written notice from the Owner stating that the Contractor is to proceed with the Work defined in the Contract Documents. Notwithstanding the Notice to Proceed, Contractor shall not be authorized to proceed with the Work until all initial Contract requirements, including the Contract, performance bond and payment bond, and certificates of insurance, have been fully executed and submitted to Owner in a suitable form.

OFFER, means a bid in connection with Instructions to Bidders or a proposal in connection with a Request for Proposals.

OFFEROR, means an entity who submits a response to a solicitation document.

OVERHEAD, means those items which may be included in the Contractor's markup (general and administrative expense and profit) and that shall not be charged as Direct Cost of the Work, including without limitation such Overhead expenses as wages or salary of personnel above the level of foreman (i.e., superintendents and project managers), expenses of Contractor's offices and supplies at the job site (e.g. job trailer) and at Contractor's principal place of business and including expenses of personnel staffing the job site office and Contractor's principal place of business, and Commercial General Liability Insurance and Automobile Liability Insurance.

OWNER, means Oregon State University (OSU). Owner may elect, by written notice to Contractor, to delegate certain duties to more than one party, including without limitation, to an Architect/Engineer. However, nothing in these General Conditions is intended to abrogate the separate design professional responsibilities of Architects under ORS Chapter 671 or of Engineers under ORS Chapter 672.

PERSON, means a natural person or entity doing business as a sole proprietorship, a partnership, a joint venture, a corporation, a limited liability company or partnership, or any other entity possessing the legal capacity to contract.

PLANS, means the drawings which show the location, type, dimensions, and details of the Work to be done under the Contract.

PROJECT, means the total design, development and construction of which the Work performed under the Contract Documents may be the whole or a part.

PUNCH LIST, means the list of Work yet to be completed or deficiencies which need to be corrected in order to achieve Final Completion of the Contract.

RECORD DOCUMENT, means the as-built Plans, Specifications, testing and inspection records, product data, samples, manufacturer and distributor/supplier warranties evidencing transfer of ownership to Owner, operational and maintenance manuals, shop drawings, Construction Change Directives, MWESB Reports, correspondence, certificate(s) of occupancy, and other documents listed in Subsection B.9.1 of these General Conditions, recording all Services performed.

SOLICITATION DOCUMENT, means a document used in a formal procurement soliciting two or more qualified sources by public notice for the same specifications and requirements

SPECIFICATION, means any description of the physical or functional characteristics of the Work, or of the nature of a supply, service or construction item. Specifications may include a description of any requirement for inspecting, testing or preparing a supply, service or construction item for delivery and the quantities or qualities of materials to be furnished under the Contract. Specifications generally will state the results or products to be obtained and may, on occasion, describe the method and manner of doing the Work to be performed. Specifications may be incorporated by reference and/or may be attached to the Contract.

SUBCONTRACT, means a contract between the Contractor and a subcontractor for the performance of a portion of the Work.

SUBCONTRACTOR, means a Person having a direct contract with the Contractor, or another Subcontractor, to perform one or more items of the Work.

SUBSTANTIAL COMPLETION, means the date when the Owner accepts in writing the construction, alteration or repair of the improvement to real property constituting the Work or any designated portion thereof as having reached that state of completion when it may be used or occupied for its intended purpose. Substantial Completion of facilities with operating systems occurs only after thirty (30) continuous Days of successful, trouble-free operation of the operating systems as provided in Section K.3.2.

SUBSTITUTIONS, means items that in function, performance, reliability, quality, and general configuration are the same or better than the product(s) specified. Approval of any substitute item shall be solely determined by the Owner. The decision of the Owner is final.

SUPPLEMENT, means a writing which, when fully executed by the Parties thereto, constitutes written agreement between the Owner and the Contractor comprised of the Contract Documents which describe the Work to be done and the obligations between the parties.

SUPPLEMENTAL GENERAL CONDITIONS, means those conditions that remove from, add to, or modify these General Conditions. Supplemental General Conditions may be included in the Solicitation Document or may be a separate attachment to the Contract.

WORK, means the furnishing of all materials, equipment, labor, transportation, services and incidentals necessary to successfully complete any individual item or the entire Contract and the carrying out of duties and obligations imposed by the Contract Documents.

A.2 SCOPE OF WORK

The Work contemplated under this Contract includes all labor, materials, transportation, equipment and services for, and incidental to, the completion of all construction work in connection with the project described in the Contract Documents. The Contractor shall perform all Work necessary so that the project can be legally occupied and fully used for the intended use as set forth in the Contract Documents.

A.3 INTERPRETATION OF CONTRACT DOCUMENTS

A.3.1 Unless otherwise specifically defined in the Contract Documents, words which have well-known technical meanings or construction industry meanings are used in the Contract Documents in accordance with such recognized meanings. Contract Documents are intended to be complementary. Whatever is called for in one is interpreted to be called for in all. However, in the event of conflicts or discrepancies among the Contract Documents, interpretations will be based on the following descending order of precedence:

- (a) Contract Supplements, Amendments and Construction Change Directives, with those of later date having precedence over those of an earlier date;
- (b) The Supplemental General Conditions;
- (c) General Conditions;
- (d) Purchase Orders;
- (e) Construction Change Directive;
- (f) Division One (General Requirements) of the Specifications;

- (g) Detailed Schedules of finishes, equipment and other items included in the Specifications;
- (h) Plans and Specifications (other than Division One and the Detailed Schedules to the Specifications);
- (i) Large-scale drawings on Plans;
- (j) Small-scale drawings on Plans;
- (k) Dimension numbers written on Plans which shall prevail and take precedence over dimensions scaled from Plans;
- (l) The Solicitation Document, and any addenda thereto;
- (m) The Master Contract.

A.3.2 In the case of an inconsistency between Plans and Specifications or within either document not clarified by addendum, the better quality or greater quantity of Work shall be provided in accordance with the Owner's interpretation in writing.

A.3.3 If the Contractor finds discrepancies in, or omissions from the Contract Documents, or if the Contractor is in doubt as to their meaning, the Contractor shall at once notify the Owner. Matters concerning and interpretation of requirements of the Contract Documents will be decided by the Owner, who may delegate that duty in some instances to the Architect/Engineer. Responses to Contractor's requests for interpretation of Contract Documents will be made in writing by Owner (or the Architect/Engineer) within any time limits agreed upon or otherwise with reasonable promptness. Interpretations and decisions of the Owner (or Architect/Engineer) will be consistent with the intent of and reasonably inferable from the Contract Documents. Contractor shall not proceed without direction in writing from the Owner (or Architect/Engineer).

A.3.4 References to standard specifications, manuals, codes of any technical society, organization or association, to the laws or regulations of any governmental authority, whether such reference be specific or by implication, shall mean the latest standard specification, manual, code, laws or regulations in effect in the jurisdiction where the project is occurring on the first published date of the Solicitation Document, except as may be otherwise specifically stated.

A.4 EXAMINATION OF PLANS, SPECIFICATIONS, AND SITE

A.4.1 It is understood that the Contractor, before submitting an Offer, has made a careful examination of the Contract Documents; has become fully informed as to the quality and quantity of materials and the character of the Work required; and has made a careful examination of the location and conditions of the Work and the sources of supply for materials. The Owner will in no case be responsible for any loss or for any unanticipated costs that may be suffered by the Contractor as a result of the Contractor's failure to acquire full information in advance in regard to all conditions pertaining to the Work. No oral agreement or conversation with any officer, agent, or personnel of the Owner, or with the Architect/Engineer either before or after the execution of this Contract, shall affect or modify any of the terms or obligations herein contained.

A.4.2 Should the Plans or Specifications fail to particularly describe the materials, kind of goods, or details of construction of any aspect of the Work, Contractor shall have the duty to make inquiry of the Owner and Architect/Engineer as to what is required prior to performance of the Work. Absent Specifications to the contrary, the materials or processes that would normally be used to produce first quality finished Work shall be considered a part of the Contract requirements.

A.4.3 Any design errors or omissions noted by the Contractor shall be reported promptly to the Owner, and confirmed in writing including without limitation, any nonconformity with Applicable Laws.

A.4.4 If the Contractor believes that adjustments to cost or Contract Time is involved because of clarifications or instructions issued by the Owner (or Architect/Engineer) in response to the Contractor's notices or requests for information, the Contractor must submit a written request to the Owner, setting forth the nature and specific extent of the request, including all time and cost impacts against the Contract as soon as possible, but no later than thirty (30) Days after receipt by Contractor of the clarifications or instructions issued. If the Owner denies Contractor's request for additional compensation, additional Contract Time, or other relief that Contractor believes results from the clarifications or instructions, the Contractor may proceed to file a Claim under Section D.3, Claims Review Process. If the Contractor fails to perform the obligations of Sections A.4.1 to A.4.3, the Contractor shall pay such costs and damages to the Owner as would have been avoided if the Contractor had performed such obligations.

A.5 INDEPENDENT CONTRACTOR STATUS

The service or services to be performed under this Contract are those of an independent contractor as defined in ORS 670.600. Contractor represents and warrants that it is not an officer, employee or agent of the Owner as those terms are used in ORS 30.265.

A.6 RETIREMENT SYSTEM STATUS AND TAXES

Contractor represents and warrants that it is not a contributing member of the Public Employees' Retirement System and will be responsible for any federal or state taxes applicable to payment received under this Contract. Contractor will not be eligible for any benefits from these Contract payments of federal Social Security, employment insurance, workers' compensation or the Public Employees' Retirement System, except as a self-employed individual. Unless the Contractor is subject to backup withholding, Owner will not withhold from such payments any amount(s) to cover Contractor's federal or state tax obligations.

A.7 GOVERNMENT EMPLOYMENT STATUS

A.7.1 If this payment is to be charged against federal funds, Contractor represents and warrants that it is not currently employed by the Federal Government. This does not preclude the Contractor from holding another contract with the Federal Government.

A.7.2 Contractor represents and warrants that Contractor is not an employee of the State of Oregon for purposes of performing Work under this Contract

SECTION B ADMINISTRATION OF THE CONTRACT

B.1 OWNER'S ADMINISTRATION OF THE CONTRACT

B.1.1 The Owner shall administer the Contract as described in the Contract Documents (1) during construction (2) until Final Payment is due and (3) during the one-year period for correction of Work. The Owner will act as provided in the Contract Documents, unless modified in writing in accordance with other provisions of the Contract. In performing these tasks, the Owner may rely on the Architect/Engineer or other consultants to perform some or all of these tasks.

B.1.2 The Owner will visit the site at intervals appropriate to the stage of the Contractor's operations (1) to become generally familiar with and to keep the Owner informed about the progress and

quality of the portion of the Work completed, (2) to endeavor to guard the Owner against defects and deficiencies in the Work, and (3) to determine in general if Work is being performed in a manner indicating that the Work, when fully completed, will be in accordance with the Contract Documents. The Owner will not make exhaustive or continuous on-site inspections to check the quality or quantity of the Work. The Owner will neither have control over or charge of, nor be responsible for the construction means, methods, techniques, sequences or procedures, or for the safety precautions and programs in connection with the Work. Inspection of the progress, quantity, or quality of the Work done by the Owner, any Owner representative, and public agency, the Architect/Engineer, or any inspector, shall not relieve the Contractor of any responsibility for the compliance of all Work with the Contract Documents.

B.1.3 Except as otherwise provided in the Contract Documents or when direct communications have been specifically authorized, the Owner and Contractor shall communicate with each other about matters arising out of or relating to the Contract. Communications by and with the Architect/Engineer's consultants shall be through the Architect/Engineer. Communications by and with Subcontractors and material suppliers shall be through the Contractor. Communications by and with separate contractors shall be through the Owner.

B.1.4 Based upon the Architect/Engineer's evaluations of the Contractor's Application for Payment, or unless otherwise stipulated by the Owner, the Architect/Engineer will review and certify the amounts due the Contractor and will issue Certificates for Payment in such amounts.

B.2 CONTRACTOR'S MEANS AND METHODS; MITIGATION OF IMPACTS

B.2.1 The Contractor shall supervise and direct the Work, using the Contractor's best skill and attention. The Contractor shall be solely responsible for and have control over construction means, methods, techniques, sequences and procedures and for coordinating all portions of the Work under the Contract, unless the Contract Documents give other specific instructions concerning these matters. If the Contract Documents give specific instructions concerning construction means, methods, techniques, sequences or procedures, the Contractor shall evaluate the jobsite safety thereof and, except as stated below, shall be fully and solely responsible for the jobsite safety of such means, methods, techniques, sequences or procedures.

B.2.2 The Contractor is responsible to protect and maintain the Work during the course of construction and to mitigate any adverse impacts to the project, including those caused by authorized changes, which may affect cost, schedule, or quality.

B.2.3 The Contractor is responsible for the actions of all its personnel, laborers, suppliers, and Subcontractors on the project. The Contractor shall enforce strict discipline and good order among Contractor's employees and other persons carrying out the Work. The Contractor shall not permit employment of persons who are unfit or unskilled for the tasks assigned to them.

B.3 MATERIALS AND WORKMANSHIP

B.3.1 The intent of the Contract Documents is to provide for the construction and completion in every detail of the Work described. All Work shall be performed in a professional manner and unless the means or methods of performing a task are specified elsewhere in the Contract Documents, Contractor shall employ methods that are generally accepted and used by the industry, in accordance with industry standards.

B.3.2 The Contractor is responsible to perform the Work as required by the Contract Documents. Defective Work shall be corrected at the Contractor's expense.

B.3.3 Work done and materials furnished shall be subject to inspection and/or observation and testing by the Owner to determine if they conform to the Contract Documents. Inspection of the Work by the Owner does not relieve the Contractor of responsibility for the Work in accordance with the Contract Documents.

B.3.4 Contractor shall furnish adequate facilities, as required, for the Owner to have safe access to the Work including without limitation walkways, railings, ladders, tunnels, and platforms. Producers, suppliers, and fabricators shall also provide proper facilities and access to their facilities.

B.3.5 The Contractor shall furnish Samples of materials for testing by the Owner and include the cost of the Samples in the Contract Price.

B.4 PERMITS

Contractor shall obtain and pay for all necessary permits, licenses and fees, except for those specifically excluded in the Supplemental General Conditions, for the construction of the Work, for temporary obstructions, enclosures, opening of streets for pipes, walls, utilities, environmental Work, etc., as required for the project. Contractor shall be responsible for all violations of the law, in connection with the construction or caused by obstructing streets, sidewalks or otherwise. Contractor shall give all requisite notices to public authorities.

B.5 COMPLIANCE WITH GOVERNMENT REGULATIONS

B.5.1 Contractor shall comply with Applicable Laws pertaining to the Work and the Contract. Failure to comply with such requirements shall constitute a breach of Contract and shall be grounds for Contract termination. Without limiting the generality of the foregoing, Contractor expressly agrees to comply with the following, as applicable:

(i) Title VI and VII of Civil Rights Act of 1964, as amended; (ii) Section 503 and 504 of the Rehabilitation Act of 1973, as amended; (iii) the Health Insurance Portability and Accountability Act of 1996; (iv) the Americans with Disabilities Act of 1990, as amended; (v) ORS Chapters 659 and 659A; as amended; (vi) all regulations and administrative rules established pursuant to the foregoing laws; and (vii) all other applicable requirements of federal and state civil rights and rehabilitation statutes, rules and regulations.

B.5.2 Contractor shall comply with all applicable requirements of federal and state civil rights and rehabilitation statutes, rules and regulations, and

(a) Contractor shall not discriminate against Disadvantaged, Minority, Women or Emerging Small Business enterprises, as those terms are defined in ORS 200.005, or a business enterprise that is owned or controlled by or that employs a disabled veteran, as that term is defined in ORS 408.225, in the awarding of subcontracts.

(b) Contractor shall maintain, in current and valid form, all licenses and certificates required by Applicable Laws or this Contract when performing the Work.

B.5.3 Unless contrary to federal law, Contractor shall certify that it shall not accept a bid from Subcontractors to perform Work as described in ORS 701.005 under this Contract unless such Subcontractors are registered with the Construction Contractors Board in accordance with ORS 701.021 to 701.068 at the time they submit their bids to the Contractor.

B.5.4 Unless contrary to federal law, Contractor shall certify that each landscape contractor, as defined in ORS 671.520(2), performing Work under this Contract holds a valid landscape contractor's license issued pursuant to ORS 671.560.

B.5.5 The following notice is applicable to Contractors who perform excavation Work. ATTENTION: Oregon law requires you to follow rules adopted by the Oregon Utility Notification Center. Those rules are set forth in OAR 952-001-0010 through OAR 952-001-0100. You may obtain copies of the rules by calling the center at (503)232-1987.

B.5.6 Failure to comply with any or all of the requirements of B.5.1 through B.5.5 shall be a breach of Contract and constitute grounds for Contract termination. Damages or costs resulting from such noncompliance shall be the responsibility of Contractor.

B.6 SUPERINTENDENCE

Contractor shall keep on the site, during the progress of the Work, a competent superintendent and any necessary assistants who shall be satisfactory to the Owner and who shall represent the Contractor on the site. Directions given to the superintendent by the Owner shall be confirmed in writing to the Contractor.

B.7 INSPECTION

B.7.1 Owner shall have access to the Work at all times.

B.7.2 Inspection of the Work will be made by the Owner at its discretion. The Owner will have authority to reject Work that does not conform to the Contract Documents. Any Work found to be not in conformance with the Contract Documents, in the discretion of the Owner, shall be removed and replaced at the Contractor's expense.

B.7.3 Contractor shall make or obtain at the appropriate time all tests, inspections and approvals of portions of the Work required by the Contract Documents or by Applicable Laws or orders of public authorities having jurisdiction. Unless otherwise provided, the Contractor shall make arrangements for such tests, inspections and approvals with an independent testing laboratory or entity acceptable to the Owner, or with the appropriate public authority, and shall bear all related costs of tests, inspections and approvals. Tests or inspections conducted pursuant to the Contract Documents shall be made promptly to avoid unreasonable delay in the Work. The Contractor shall give the Owner timely notice of when and where tests and inspections are to be made so that the Owner may be present for such procedures. Required certificates of testing, inspection or approval shall, unless otherwise required by the Contract Documents, be secured by the Contractor and promptly delivered to the Owner.

B.7.4 As required by the Contract Documents, Work done or material used without required inspection or testing and/or without providing timely notice to the Owner may be ordered removed at the Contractor's expense.

B.7.5 If directed to do so any time before the Work is accepted, the Contractor shall uncover portions of the completed Work for inspection. After inspection, the Contractor shall restore such portions of Work to the standard required by the Contract. If the Work uncovered is unacceptable or was done without required testing or inspection or sufficient notice to the Owner, the uncovering and restoration shall be done at the Contractor's expense. If the Work uncovered is acceptable and was done with sufficient notice to the Owner, the uncovering and restoration will be paid for pursuant to a Supplement Amendment.

B.7.6 If any testing or inspection reveals failure of the portions of the Work to comply with requirements established by the Contract Documents, all costs made necessary by such failure, including those of repeated procedures and compensation for the Owner's and Architect/Engineer's services and expenses, shall be at the Contractor's expense.

B.7.7 When the United States government participates in the cost of the Work, or the Owner has an agreement with other public or private organizations, or if any portion of the Work is being performed for a third party or in close proximity to third party facilities, representatives of these organizations shall have the right to inspect the Work affecting their interests or property. Their right to inspect shall not make them a party to the Contract and shall not interfere with the rights of the parties of the Contract. Instructions or orders of such parties shall be transmitted to the Contractor, through the Owner.

B.8 SEVERABILITY

If any provision of this Contract is declared by a court to be illegal or in conflict with any law, the validity of the remaining terms and provisions shall not be affected and the rights and obligations of the parties shall be construed and enforced as if the Contract did not contain the particular provision held to be invalid.

B.9 ACCESS TO RECORDS

B.9.1 Contractor shall keep, at all times on the Work site, one record copy of the complete Contract Documents, including the Plans, Specifications, Construction Change Directives and addenda, in good order and marked currently to record field changes and selections made during construction, and one record copy of Shop Drawings, Product Data, Samples and similar submittals, and shall at all times give the Owner access thereto.

B.9.2 Contractor shall retain and the Owner and its duly authorized representatives shall have access, for a period not less than ten (10) years, to all Record Documents, financial and accounting records, and other books, documents, papers and records of Contractor which are pertinent to the Contract, including records pertaining to Overhead and indirect costs, for the purpose of making audit, examination, excerpts and transcripts. If for any reason, any part of the Work or this Contract shall be subject to litigation, Contractor shall retain all such records until all litigation is resolved and Contractor shall continue to provide Owner and/or its agents with full access to such records until such time as all litigation is complete and all periods for appeal have expired and full and final satisfaction of any judgment, order or decree is recorded and Owner receives a record copy of documentation from Contractor.

B.10 WAIVER

Failure of the Owner to enforce any provision of this Contract shall not constitute a waiver or relinquishment by the Owner of the right to such performance in the future nor of the right to enforce any other provision of this Contract.

B.11 SUBCONTRACTS AND ASSIGNMENT

B.11.1 Contractor shall require each Subcontractor, to the extent of the Work to be performed by the Subcontractor, to be bound by the terms and conditions of these General Conditions, and to assume toward the Contractor all of the obligations and responsibilities which the Contractor assumes toward the Owner thereunder, unless (1) the same are clearly inapplicable to the subcontract at issue because of legal requirements or industry practices, or (2) specific exceptions are requested by Contractor and approved in writing by Owner. Where appropriate, Contractor shall require each Subcontractor to

enter into similar agreements with sub-subcontractors at any level.

B.11.2 At Owner's request, Contractor shall submit to Owner prior to their execution either Contractor's form of subcontract, or the subcontract to be executed with any particular Subcontractor. If Owner disapproves such form, Contractor shall not execute the form until the matters disapproved are resolved to Owner's satisfaction. Owner's review, comment upon or approval of any such form shall not relieve Contractor of its obligations under this Agreement or be deemed a waiver of such obligations of Contractor.

B.11.3 Contractor shall not assign, sell, or transfer its rights, or delegate its responsibilities under this Contract, in whole or in part, without the prior written approval of the Owner. No such written approval shall relieve Contractor of any obligations of this Contract, and any transferee shall be considered the agent of the Contractor and bound to perform in accordance with the Contract Documents. Contractor shall remain liable as between the original parties to the Contract as if no assignment had occurred.

B.12 SUCCESSORS IN INTEREST

The provisions of this Contract shall be binding upon and shall accrue to the benefit of the parties to the Contract and their respective permitted successors and assigns.

B.13 OWNER'S RIGHT TO DO WORK

Owner reserves the right to perform other or additional work at or near the project site with other forces than those of the Contractor. If such work takes place within or next to the project site, Contractor shall coordinate work with the other contractors or forces, cooperate with all other contractors or forces, carry out the Work in a way that will minimize interference and delay for all forces involved, place and dispose of materials being used so as not to interfere with the operations of another, and join the Work with the work of the others in an acceptable manner and perform it in proper sequence to that of the others. The Owner will resolve any disagreements that may arise between or among Contractor and the other contractors over the method or order of doing all work (including the Work). In case of unavoidable interference, the Owner will establish work priority (including the Work) which generally will be in the sequence that the contracts were awarded.

B.14 OTHER CONTRACTS

In all cases and at any time, the Owner has the right to execute other contracts related to or unrelated to the Work of this Contract. The Contractor of this Contract shall fully cooperate with any and all other contractors without additional cost to the Owner in the manner described in section B.13.

B.15 GOVERNING LAW

This Contract shall be governed by and construed in accordance with the laws of the State of Oregon without regard to principles of conflict of laws.

B.16 LITIGATION

Any Claim between Owner and Contractor that arises from or relates to this Contract and that is not resolved through the Claims Review Process in Section D.3 shall be brought and conducted solely and exclusively within the Circuit Court of Benton County for the State of Oregon; provided, however, if a Claim must be brought in a federal forum, then it shall be brought and conducted solely and exclusively within the United States District Court for the District of Oregon. In no event shall this section be construed as a waiver by the State of Oregon of any form of defense or immunity, whether sovereign immunity,

governmental immunity, immunity based on the Eleventh Amendment to the Constitution of the United States or otherwise, from any claim or from the jurisdiction of any court. CONTRACTOR, BY EXECUTION OF THIS CONTRACT, HEREBY CONSENTS TO THE IN PERSONAM JURISDICTION OF THE COURTS REFERENCED IN THIS SECTION B.16.

B.17 ALLOWANCES

B.17.1 The Contractor shall include in the Contract Price all allowances stated in the Contract Documents. Items covered by allowances shall be supplied for such amounts and by such persons or entities as the Owner may direct.

B.17.2 Unless otherwise provided in the Contract Documents:

- (a) When finally reconciled, allowances shall cover the cost to the Contractor of materials and equipment delivered at the site and all required taxes, less applicable trade discounts;
- (b) Contractor's costs for unloading and handling at the site, labor, installation costs, Overhead, profit and other expenses contemplated for stated allowance amounts shall be included in the Contract Price but not in the allowances;
- (c) Whenever costs are more than or less than allowances, the Contract Price shall be adjusted accordingly by Amendment. The amount of the Amendment shall reflect (i) the difference between actual costs and the allowances under Section B.17.2(a) and (2) changes in Contractor's costs under Section B.17.2(b).
- (d) Unless Owner requests otherwise, Contractor shall provide to Owner a proposed fixed price for any allowance work prior to its performance.

B.18 SUBMITTALS, SHOP DRAWINGS, PRODUCT DATA AND SAMPLES

B.18.1 The Contractor shall prepare and keep current, for the Architect's/Engineer's approval (or for the approval of Owner if approval authority has not been delegated to the Architect/Engineer), a schedule and list of Submittals which is coordinated with the Contractor's construction schedule and allows the Architect/Engineer reasonable time to review Submittals. Owner reserves the right to finally approve the schedule and list of Submittals. Submittals include, without limitation, Shop Drawings, product data, and samples which are described below:

- (a) Shop Drawings are drawings, diagrams, schedules and other data specially prepared for the Work by the Contractor or a Subcontractor (including any sub-subcontractor), manufacturer, supplier or distributor to illustrate some portion of the Work.
- (b) Product Data are illustrations, standard schedules, performance charts, instructions, brochures, diagrams and other information furnished by the Contractor to illustrate materials or equipment for some portion of the Work.
- (c) Samples are physical examples which illustrate materials, equipment or workmanship and establish standards by which the Work will be judged.

B.18.2 Shop Drawings, Product Data, Samples and similar Submittals are not Contract Documents. The purpose of their Submittal is to demonstrate for those portions of the Work for which Submittals are required by the Contract Documents the way by which the Contractor proposes to conform to the information given and the design concept expressed in the Contract Documents. Review of Submittals by the Architect/Engineer is

not conducted for the purpose of determining the accuracy and completeness of other details such as dimensions and quantities, or for substantiating instructions for installation or performance of equipment or systems, or for approval of safety precautions or, unless otherwise specifically stated by the Architect/Engineer, of any construction means, methods, techniques, sequences or procedures, all of which remain the responsibility of the Contractor as required by the Contract Documents. The Architect/Engineer's review of the Contractor's Submittals shall not relieve the Contractor of its obligations under the Contract Documents. The Architect/Engineer's approval of a specific item shall not indicate approval of an assembly of which the item is a component. Informational Submittals upon which the Architect/Engineer is not expected to take responsive action may be so identified in the Contract Documents. Submittals which are not required by the Contract Documents may be returned by the Architect/Engineer without action.

- B.18.3 The Contractor shall review for compliance with the Contract Documents, approve and submit to the Architect/Engineer Shop Drawings, Product Data, Samples and similar Submittals required by the Contract Documents with reasonable promptness and in such sequence as to cause no delay in the Work or in the activities of the Owner or of separate contractors. Submittals which are not marked as reviewed for compliance with the Contract Documents and approved by the Contractor may be returned by the Architect/Engineer without action.
- B.18.4 Approving and submitting shop drawings, product data, samples and similar Submittals, the Contractor represents that the Contractor has determined and verified materials, field measurements and field construction criteria related thereto, or will do so, and has checked and coordinated the information contained within such Submittals with the requirements of the Work and of the Contract Documents.
- B.18.5 The Contractor shall perform no portion of the Work for which the Contract Documents require submittal and review of Shop Drawings, Product Data, Samples or similar Submittals until the respective Submittal has been approved by the Architect/Engineer.
- B.18.6 The Work shall be in accordance with approved Submittals except that the Contractor shall not be relieved of responsibility for deviations from requirements of the Contract Documents by the Architect/Engineer's review or approval of Shop Drawings, Product Data, Samples or similar Submittals unless the Contractor has specifically informed the Architect/Engineer in writing of such deviation at the time of submittal and (i) the Architect/Engineer has given written approval to the specific deviation as a minor change in the Work, or (ii) a Supplement Amendment or Construction Change Directive has been executed by Owner authorizing the deviation. The Contractor shall not be relieved of responsibility for errors or omissions in Shop Drawings, Product Data, Samples or similar Submittals by the Architect/Engineer's review or approval thereof.
- B.18.7 In the event that Owner elects not to have the obligations and duties described under this Section B.18 performed by the Architect/Engineer, or in the event no Architect/Engineer is employed by Owner on the project, all obligations and duties assigned to the Architect/Engineer hereunder shall be performed by the Owner.

B.19 SUBSTITUTIONS

The Contractor may make Substitutions only with the written consent of the Owner, after evaluation by the Owner and only in accordance with a Supplement Amendment or Construction Change Directive. Substitutions shall be subject to the requirements of the bid

documents. By making requests for Substitutions, the Contractor represents that the Contractor has personally investigated the proposed substitute product; represents that the Contractor will provide the same warranty for the Substitution that the Contractor would for the product originally specified unless approved otherwise; certifies that the cost data presented is complete and includes all related costs under this Contract including redesign costs, and waives all claims for additional costs related to the Substitution which subsequently become apparent; and will coordinate the installation of the accepted Substitution, making such changes as may be required for the Work to be completed in all respects.

B.20 USE OF PLANS AND SPECIFICATIONS

Plans, Specifications and related Contract Documents furnished to Contractor by Owner or Owner's Architect/Engineer shall be used solely for the performance of the Work under this Contract. Contractor and its Subcontractors and suppliers are authorized to use and reproduce applicable portions of such documents appropriate to the execution of the Work, but shall not claim any ownership or other interest in them beyond the scope of this Contract, and no such interest shall attach. Unless otherwise indicated, all common law, statutory and other reserved rights, in addition to copyrights, are retained by Owner.

B.21 FUNDS AVAILABLE AND AUTHORIZED

If Owner fails to receive funding, appropriations, allocations or other expenditure authority as contemplated by Owner's budget and Owner determines, in its assessment and ranking of the policy objectives explicit or implicit in Owner's budget, Owner may determine it is necessary to and may terminate this Master Contract and or any Amendments.

B.22 NO THIRD PARTY BENEFICIARIES

Owner and Contractor are the only parties to this Contract and are the only parties entitled to enforce its terms. Nothing in this Contract gives, is intended to give, or shall be construed to give or provide any benefit or right, whether directly, indirectly, or otherwise, to third persons unless such third persons are individually identified by name herein and expressly described as intended beneficiaries of the terms of this Contract.

SECTION C WAGES AND LABOR

C.1 MINIMUM WAGE RATES ON PUBLIC WORKS

Contractor shall comply fully with the provisions of ORS 279C.800 through 279C.870. Documents establishing those conditions, as determined by the Commissioner of the Bureau of Labor and Industries (BOLI), are included as attachments to or are incorporated by reference in the Contract Documents. Pursuant to ORS 279C.830(1)(c), Contractor shall pay workers at not less than the specified minimum hourly rate of wage, and shall include that requirement in all subcontracts. If the Work is subject to both the state prevailing wage rate law and the federal Davis-Bacon Act, Contractor shall pay the higher of the applicable state or federal prevailing rate of wage. Contractor shall provide written notice to all workers of the number of hours per day and days per week such workers may be required to work.

C.2 PAYROLL CERTIFICATION AND FEE REQUIREMENTS

C.2.1 In accordance with ORS 279C.845, the Contractor and every Subcontractor shall submit written certified statements to the Owner, on the form prescribed by the Commissioner of the Bureau of Labor and Industries, certifying the hourly rate of wage paid each worker which the Contractor or the Subcontractor has employed on the project and further certifying that no worker employed on the project has been paid less than

the prevailing rate of wage or less than the minimum hourly rate of wage specified in the Contract, which certificate and statement shall be verified by the oath of the Contractor or the Subcontractor that the Contractor or Subcontractor has read the certified statement, that the Contractor or Subcontractor knows the contents of the certified statement, and, that to the Contractor's or Subcontractor's best knowledge and belief, the certified statement is true. The certified statements shall set out accurately and completely the payroll records for the prior week, including the name and address of each worker, the worker's correct classification, rate of pay, daily and weekly number of hours worked, deductions made, and actual wages paid. Certified statements for each week during which the Contractor or Subcontractor has employed a worker on the project shall be submitted once a month, by the fifth business day of the following month. The Contractor and Subcontractors shall preserve the certified statements for a period of ten (10) years from the date of completion of the Contract.

- C.2.2 Pursuant to ORS 279C.845(7), the Owner shall retain 25 percent of any amount earned by the Contractor on this public works project until the Contractor has filed the certified statements required by section C.2.1. The Owner shall pay to the Contractor the amount retained under this subsection within 14 days after the Contractor files the required certified statements, regardless of whether a Subcontractor has failed to file certified statements.
- C.2.3 Pursuant to ORS 279C.845(8), the Contractor shall retain 25 percent of any amount earned by a first-tier Subcontractor on this public works project until the first-tier Subcontractor has filed with the Owner the certified statements required by C.2.1. Before paying any amount retained under this subsection, the Contractor shall verify that the first-tier Subcontractor has filed the certified statement. Within 14 days after the first-tier Subcontractor files the required certified statement the Contractor shall pay the first-tier Subcontractor any amount retained under this subsection.
- C.2.4 In accordance with statutory requirements and administrative rules promulgated by the Commissioner of the Bureau of Labor and Industries, the fee required by ORS 279C.825(1) will be paid by Owner to the Commissioner.

C.3 PROMPT PAYMENT AND CONTRACT CONDITIONS

- C.3.1 As a condition to Owner's performance hereunder, the Contractor shall:
 - C.3.1.1 Make payment promptly, as due, to all persons supplying to Contractor labor or materials for the prosecution of the Work provided for in this Contract.
 - C.3.1.2 Pay all contributions or amounts due the State Industrial Accident Fund from such Contractor or Subcontractor incurred in the performance of the Contract.
 - C.3.1.3 Not permit any lien or claim to be filed or prosecuted against the Owner on account of any labor or material furnished. Contractor will not assign any claims that Contractor has against Owner, or assign any sums due by Owner, to Subcontractors, suppliers, or manufacturers, and will not make any agreement or act in any way to give Subcontractors a claim or standing to make a claim against the Owner.
 - C.3.1.4 Pay to the Department of Revenue all sums withheld from employees pursuant to ORS 316.167.
- C.3.2 As a condition to Owner's performance hereunder, if Contractor fails, neglects or refuses to make prompt payment of any claim for labor or services furnished to the Contractor of a

Subcontractor by any person in connection with the project as such claim becomes due, the proper officer(s) representing the Owner may pay the claim and charge the amount of the payment against funds due or to become due Contractor under this Contract. Payment of claims in this manner shall not relieve the Contractor or the Contractor's surety from obligation with respect to any unpaid claims.

- C.3.3 Contractor shall include in each subcontract for property or services entered into by the Contractor and a first-tier subcontractor, including a material supplier, for the purpose of performing a construction contract, a payment clause that obligates the Contractor to pay the first-tier Subcontractor for satisfactory performance under its subcontract within ten (10) Days out of such amounts as are paid to the Contractor by the public contracting agency under such contract.
- C.3.4 All employers, including Contractor, that employ subject workers who work under this contract in the State of Oregon shall comply with ORS 656.017 and provide the required Workers' Compensation coverage, unless such employers are exempt under ORS 656.126. Contractor shall ensure that each of its Subcontractors complies with these requirements.

C.4 PAYMENT FOR MEDICAL CARE

As a condition to Owner's performance hereunder, Contractor shall promptly, as due, make payment to any person, partnership, association or corporation furnishing medical, surgical, and hospital care or other needed care and attention, incident to sickness or injury, to the employees of such Contractor, all sums of which the Contractor agrees to pay for such services and all moneys and sums which the Contractor has collected or deducted from the wages of personnel pursuant to any law, contract or agreement for the purpose of providing or paying for such services.

C.5 HOURS OF LABOR

As a condition to Owner's performance hereunder, no person shall be employed to perform Work under this Contract for more than ten (10) hours in any one day or forty (40) hours in any one week, except in cases of necessity, emergency or where public policy absolutely requires it. In such instances, Contractor shall pay the employee at least time and a half pay:

- (a) For all overtime in excess of eight (8) hours a day or forty (40) hours in any one week when the work week is five consecutive Days, Monday through Friday; or
- (b) For all overtime in excess of ten (10) hours a day or forty (40) hours in any one week when the work week is four consecutive Days, Monday through Friday; and
- (c) For all Work performed on Saturday and on any legal holiday specified in ORS 279C.540.

This section C.5 will not apply to Contractor's Work under this Contract to the extent Contractor is currently a party to a collective bargaining agreement with any labor organization.

This Section C.5 shall not excuse Contractor from completion of the Work within the time required under this Contract.

SECTION D CHANGES IN THE WORK

D.1 CHANGES IN WORK

- D.1.1 The terms of this Contract shall not be waived, altered, modified, supplemented or amended in any manner whatsoever, without prior written agreement and then only after any necessary approvals have been obtained. A Supplement or Amendment is

required, which shall not be effective until its execution by the parties to this Contract and all approvals required by public contracting laws have been obtained.

D.1.2 It is mutually agreed that changes in Plans, quantities, or details of construction are inherent in the nature of construction and may be necessary or desirable during the course of construction. Within the general scope of this Contract, the Owner may at any time, without notice to the sureties and without impairing the Contract, require changes consistent with this Section D.1. All changes to the Work shall be documented and Amendments shall be executed under the conditions of the Contract Documents. Such changes may include, but are not limited to:

- (a) Modification of specifications and design.
- (b) Increases or decreases in quantities.
- (c) Increases or decreases to the amount of Work.
- (d) Addition or elimination of any Work item.
- (e) Change in the duration of the project.
- (f) Acceleration or delay in performance of Work.
- (g) Deductive changes,
- (h) Changed conditions.

Deductive changes are those that reduce the scope of the Work, and shall be made by mutual agreement whenever feasible. In cases of suspension or partial termination under Section J, Owner reserves the right to unilaterally impose a deductive change and to self-perform such Work, for which the provisions of B.13 (Owner's Right to Do Work) shall then apply. Adjustments in compensation shall be made under the provisions of D.1.3, in which costs for deductive changes shall be based upon a Direct Costs adjustment together with the related percentage markup specified for profit, Overhead and other indirect costs, unless otherwise agreed to by Owner.

D.1.3 The Owner and Contractor agree that adjustments to or deletions from the Work shall be administered and compensated according to the following:

- (a) Unit pricing may be utilized at the Owner's option when unit prices or solicitation alternates were provided that established the cost for adjustments to Work, and a binding obligation exists under the Contract on the parties covering the terms and conditions of the adjustment to Work.
- (b) If the Owner elects not to utilize unit pricing, or in the event that unit pricing is not available or appropriate, fixed pricing may be used for adjustments to or deletions from the Work. In fixed pricing, the basis of payments or total price shall be agreed upon in writing between the parties to the Contract, and shall be established before the Work is done whenever feasible. Notwithstanding the foregoing, the mark-ups set forth in D.1.3(c) shall be utilized in establishing fixed pricing, and such mark-ups shall not be exceeded. Cost and price data relating to adjustments to or deletions from the Work shall be supplied by Contractor to Owner upon request, but Owner shall be under no obligation to make such requests.
- (c) In the event that unit pricing and fixed pricing are not utilized, then adjustments to or deletions from the Work shall be performed on a cost reimbursement basis for Direct Costs. Such Work shall be compensated on the basis of the actual, reasonable and allowable cost of labor, equipment, and material furnished on the Work performed. In addition, the following markups shall be added to the Contractor's or Subcontractor's Direct Costs as full compensation for profit, Overhead and other indirect costs for Work directly performed with the Contractor's or Subcontractor's own forces:

On Labor.....	15%
On Equipment.....	10%

On Materials..... 10%

- (d) When adjustments to or deletions from the Work under D.1.3(c) are invoiced by an authorized Subcontractor at any level, each ascending tier Subcontractor or Contractor will be allowed a supplemental mark-up on each piece of subcontract Work covered by a an Amendment as follows:

\$0.00 - \$5,000.00	10%, and then
Over \$5,000.00	5%

Notwithstanding the foregoing, the maximum aggregate markup to be billed shall not exceed 10% regardless of the number of subcontract tiers

Payments made to the Contractor shall be complete compensation for Overhead, profit, and all costs that were incurred by the Contractor or by other forces furnished by the Contractor, including Subcontractors, for adjustments to or deletions from the Work pursuant to a Supplement Amendment. Owner may establish a maximum cost for additional Work under this Section D.1.3, which shall not be exceeded for reimbursement without additional written authorization from Owner in the form of a Supplement Amendment. Contractor shall not be required to complete such additional Work without additional authorization.

Any necessary adjustment of Contract Time that may be required as a result of adjustments to or deletions from the Work must be agreed upon by the parties before the start of the revised Work unless Owner authorizes Contractor to start the revised Work before agreement on Contract Time adjustment. Contractor shall submit any request for additional compensation (and additional Contract Time if Contractor was authorized to start Work before an adjustment of Contract Time was approved) as soon as possible but no later than thirty (30) Days after receipt of Owner's request for additional Work. Contractor agrees that this thirty (30) Day notice period is adequate time for it to request and document the amount of additional compensation or adjustment of Contract Time. If Contractor's request for additional compensation or adjustment of Contract Time is not made within the thirty (30) Day time limit, Contractor agrees its requests pertaining to that additional Work shall be barred. The thirty (30) Day time limit for making requests shall not be extended for any reason, including without limitation Contractor's claimed inability to determine the amount of additional compensation or adjustment of Contract Time, unless an extension is granted in writing by Owner. If the Owner denies Contractor's timely request for additional compensation or adjustment of Contract Time, Contractor may proceed to file a Claim under Section D.3, Claims Review Process. No other reimbursement, compensation, or payment will be made, except as provided in Section D.1.5 for impact claims.

- D.1.4 If any adjustment to Work under Section D.1.3 causes an increase or decrease in the Contractor's cost of, or the Contract Time required for the performance of any other part of the Work under this Contract, Contractor shall submit a written request to the Owner, setting forth the nature and specific extent of the request, including all time and cost impacts against the Contract as soon as possible, but no later than thirty (30) Days after receipt of Owner's request for adjustments to or deletions from the Work by Contractor.

The thirty (30) Day time limit applies to claims of Subcontractors, suppliers, or manufacturers who may be affected by Owner's request for adjustments to or deletions from the Work and who request additional compensation or an extension of Contract Time to perform; Contractor has responsibility for contacting its Subcontractors, suppliers, or

manufacturers within the thirty (30) Day time limit, and including their requests with Contractor's requests. If the request involves Work to be completed by Subcontractors, or materials to be furnished by suppliers or manufacturers, such requests shall be submitted to the Contractor in writing with full analysis and justification for the adjustments to compensation and Contract Time requested. The Contractor shall analyze and evaluate the merits of the requests submitted by Subcontractors, suppliers, and manufacturers to Contractor prior to including those requests and Contractor's analysis and evaluation of those requests with Contractor's requests for adjustments to compensation or Contract Time that Contractor submits to the Owner. Failure of Subcontractors, suppliers, manufacturers or others to submit their requests to Contractor for inclusion with Contractor's requests submitted to Owner within the time period and by the means described in this section shall constitute a waiver of these Subcontractor claims. The Owner will not consider direct requests or claims from Subcontractors, suppliers, manufacturers or others not a party to this Contract. The consideration of such requests and claims under this section does not give any Person, not a party to the Contract the right to bring a claim against Owner, whether in this claims process, in litigation, or in any dispute resolution process.

If the Owner denies the Contractor's request for adjustment to compensation or Contract Time, and the request is timely as set forth herein, the Contractor may proceed to file a Claim under Section D.3, Claims Review Process.

D.1.5 Contractor agrees that no request or Claim for additional costs or an adjustment of Contract Time shall be allowed if made after receipt of Final Payment application under this Contract. Final Payment application must be made by Contractor within the time required under Section E.6.4.

D.1.6 It is understood that changes in the Work are inherent in construction of this type. The number of changes, the scope of those changes, and the effect they have on the progress of the original Work cannot be defined at this time. The Contractor is notified that numerous changes may be required and that there will be no compensation made, unless and only to the extent otherwise provided in the Contract Documents, to the Contractor directly related to the number of changes. Each change will be evaluated for extension of Contract Time and increase or decrease in compensation based on its own merit.

D.2 DELAYS

D.2.1 Delays in construction include "Avoidable Delays", which are defined in Section D.2.1.1, and "Unavoidable Delays", which are defined in Section D.2.1.2. The effect of Avoidable Delays is described in Section D.2.2 and the effect of Unavoidable Delays is described in Section D.2.3.

D.2.1.1 Avoidable Delays include any delays other than Unavoidable Delays, and include delays that otherwise would be considered Unavoidable Delays but that:

- (a) Could have been avoided by the exercise of care, prudence, foresight, and diligence on the part of the Contractor or its Subcontractors.
- (b) Affect only a portion of the Work and do not necessarily prevent or delay the prosecution of other parts of the Work or the completion of the whole Work within the Contract Time.
- (c) Do not impact activities on the accepted CPM Construction Schedule.
- (d) Are associated with the reasonable interference of other contractors employed by the Owner that do not necessarily

prevent the completion of the whole Work within the Contract Time.

D.2.1.2 Unavoidable Delays include delays other than Avoidable Delays that are:

- (a) To the extent caused by any actions of the Owner, or any other employee or agent of the Owner, or by separate contractor employed by the Owner.
- (b) To the extent caused by any site conditions that differ materially from what was represented in the Contract Documents or from conditions that would normally be expected to exist and be inherent to the construction activities defined in the Contract Documents. The Contractor agrees to notify the Owner immediately of differing site conditions before the area has been disturbed. The Owner will investigate the area and make a determination as to whether the conditions differ materially from either the conditions stated in the Contract Documents or those that could reasonably be expected in execution of this particular Contract. If Contractor and Owner agree that a differing site condition exists, any adjustment to compensation or Contract Time will be determined based on the process set forth in Section D.1.5 for adjustments to or deletions from Work. If the Owner disagrees that a differing site condition exists and denies Contractor's request for additional compensation or Contract Time, Contractor may proceed to file a Claim under Section D.3, Claims Review Process.
- (c) To the extent caused by Force Majeure acts, events or occurrences that could not have been avoided by the exercise of care, prudence, foresight, and diligence on the part of the Contractor or its Subcontractors.
- (d) To the extent caused by adverse weather conditions. Any adverse weather conditions must be substantiated by documentary evidence that weather conditions were abnormal for the specific time period claimed, could not have been anticipated by the Contractor, and adversely impacted the Project in a manner that could not be avoided by rescheduling the Work or by implementing measures to protect against the weather so that the Work could proceed. A rain, windstorm, high water, or other natural phenomenon for the specific locality of the Work, which might reasonably have been anticipated from the previous 10-year historical records of the general locality of the Work, shall not be construed as abnormal. The parties agree that rainfall greater than the following levels cannot be reasonably anticipated:

- (i) Daily rainfall equal to, or greater than, 0.50 inch during a month when the monthly rainfall exceeds the normal monthly average by twenty-five percent (25 %) or more.
- (ii) daily rainfall equal to, or greater than, 0.75 inch at any time.

The Office of the Environmental Data Service of the National Oceanic and Atmospheric Administration of the U.S. Department of Commerce nearest the Project site shall be considered the official agency of record for weather information.

D.2.2 Contractor agrees it is not be entitled to additional compensation or additional Contract Time for Avoidable Delays.

D.2.3 In the event of Unavoidable Delays, based on principles of equitable adjustment, Contractor may be entitled to the following:

- (a) Contractor may be entitled to additional compensation or additional Contract Time, or both, for Unavoidable Delays described in Section D.2.1.2 (a) and (b).
- (b) Contractor may be entitled to additional Contract Time for Unavoidable Delays described in Section D.2.1.2(c) and (d).

In the event of any requests for additional compensation or additional Contract Time, or both, as applicable, arising under this Section D.2.3 for Unavoidable Delays, other than requests for additional compensation or additional Contract Time for differing site conditions for which a review process is established under Section D.2.1.2 (b), Contractor must submit a written notification of the delay to the Owner within two (2) Days of the occurrence of the cause of the delay. This written notification shall state the cause of the potential delay, the project components impacted by the delay, and the anticipated additional Contract Time extension or the additional compensation, or both, as applicable, resulting from the delay. Within seven (7) Days after the cause of the delay has been mitigated, or in no case more than thirty (30) Days after the initial written notification, the Contractor agrees to submit to the Owner, a complete and detailed request for additional compensation or additional Contract Time, or both, as applicable, resulting from the delay. If the Owner denies Contractor's request for additional compensation or adjustment of Contract Time, the Contractor may proceed to file a Claim under Section D.3, Claims Review Process, provided Contractor has complied with the requirement in this Section D.2.3. Contractor agrees any Claim it may have is barred if Contractor does not comply with the requirements herein.

If Contractor does not timely submit the notices required under this Section D.2, then unless otherwise prohibited by law, Contractor's Claim shall be barred.

D.3 CLAIMS REVIEW PROCESS

- D.3.1 All Contractor Claims shall be referred to the Owner for review. Contractor's Claims, including Claims for adjustments to compensation or Contract Time, shall be submitted in writing by Contractor to the Owner within five (5) Days after a denial of Contractor's initial request for an adjustment of Contract terms, payment of money, extension of Contract Time or other relief, provided that such initial request has been submitted in accordance with the requirements and within the time limits established in these General Conditions. Within thirty (30) Days after the initial Claim, Contractor shall submit to the Owner a complete and detailed description of the Claim (the "Detailed Notice") that includes all information required by Section D.3.2. Contractor agrees that, unless the Claim is made in accordance with these time requirements, Contractor voluntarily waived all rights to prosecute its Claim.
- D.3.2 The Detailed Notice of the Claim shall be submitted in writing by Contractor and shall include a detailed, factual statement of the basis of the Claim, pertinent dates, Contract provisions which support or allow the Claim, reference to or copies of any documents which support the Claim, the dollar value of the Claim, and the Contract Time adjustment requested for the Claim. If the Claim involves Work to be completed by Subcontractors, the Contractor will analyze and evaluate the merits of the Subcontractor claim prior to forwarding it and that analysis and evaluation to the Owner. The Owner will not consider direct claims from Subcontractors, suppliers, manufacturers, or others not a party to this Contract. Contractor agrees that it will make no agreement, covenant, or assignment, nor will it commit any other act that will permit or assist any Subcontractor, supplier, manufacturer, or other to directly or indirectly make a claim against Owner.

- D.3.3 The Owner will review all Claims and take one or more of the following preliminary actions within ten (10) Days of receipt of the Detailed Notice of a Claim: (1) request additional supporting information from the Contractor; (2) inform the Contractor and Owner in writing of the time required for adequate review and response; (3) reject the Claim in whole or in part and identify the reasons for rejection; (4) based on principles of equitable adjustment, recommend approval of all or part of the Claim; or (5) propose an alternate resolution.
- D.3.4 The Owner's decision shall be final and binding on the Contractor unless appealed by written notice to the Owner within fifteen (15) Days of receipt of the decision. The Contractor must present written documentation supporting the Claim within fifteen (15) Days of the notice of appeal. After receiving the appeal documentation, the Owner shall review the materials and render a decision within thirty (30) Days after receiving the appeal documents.
- D.3.5 The decision of the Owner shall be final and binding unless the Contractor delivers to the Owner its request for mediation, which shall be a non-binding process, within fifteen (15) Days of the date of the Owner's decision. The mediation process will be considered to have commenced as of the date the Contractor delivers the request. Both parties acknowledge and agree that participation in mediation is a prerequisite to commencement of litigation of any disputes relating to the Contract. Both parties further agree to exercise their best efforts in good faith to resolve all disputes within sixty (60) Days of the commencement of the mediation through the mediation process set forth herein.

In the event that a lawsuit must be filed within this sixty (60) Day period in order to preserve a cause of action, the parties agree that, notwithstanding the filing, they shall proceed diligently with the mediation to its conclusion prior to actively prosecuting the lawsuit, and shall seek from the Court in which the lawsuit is pending such stays or extensions, including the filing of an answer, as may be necessary to facilitate the mediation process. Further, in the event settlements are reached on any issues through mediation, the plaintiff shall promptly cause to be entered by the Court a stipulated general judgment of dismissal with prejudice, or other appropriate order limiting the scope of litigation as provided in the settlement.

- D.3.6 Should the parties arrive at an impasse regarding any Claims or disputed Claims, it is agreed that the parties shall participate in mediation as specified in Section D.3.5. The mediation process will be considered to have been commenced as of the date one party delivers to the other its request in writing to mediate. The mediator shall be an individual mutually acceptable to both parties, but in the absence of agreement each party shall select a temporary mediator and the temporary mediators shall jointly select the permanent mediator. Each party shall pay its own costs for the time and effort involved in mediation. The cost of the mediator shall be split equally between the two parties. Both parties agree to exercise their best effort in good faith to resolve all disputes in mediation. Participation in mediation is a mandatory requirement of both the Owner and the Contractor. The schedule, time and place for mediation will be mutually acceptable, or, failing mutual agreement, shall be as established by the mediator. The parties agree to comply with Owner's administrative rules governing the confidentiality of mediation, if any, and shall execute all necessary documents to give effect to such confidentiality rules. In any event, the parties shall not subpoena the mediator or otherwise require the mediator to produce records, notes or work product, or to testify in any future proceedings as to information disclosed or representations made in the course of mediation, except to the extent disclosure is required by law.

D.3.7 Unless otherwise directed by Owner, Contractor shall proceed with the Work while any Claim, or mediation or litigation arising from a Claim, is pending. Regardless of the review period or the final decision of the Owner, the Contractor shall continue to diligently pursue the Work as identified in the Contract Documents. In no case is the Contractor justified or allowed to cease or Delay Work, in whole or in part, without a written stop work order from the Owner.

SECTION E PAYMENTS

E.1 SCHEDULE OF VALUES

The Contractor shall submit, at least ten (10) Days prior to submission of its first application for progress payment, a schedule of values ("Schedule of Values") for the contracted Work. This schedule shall provide a breakdown of values for the contracted Work and will be the basis for progress payments. The breakdown shall demonstrate reasonable, identifiable, and measurable components of the Work. Unless objected to by the Owner, this schedule shall be used as the basis for reviewing Contractor's applications for payment. If objected to by Owner, Contractor shall revise the schedule of values and resubmit the same for approval of Owner.

E.2 APPLICATIONS FOR PAYMENT

E.2.1 Owner shall make progress payments on the Contract monthly as Work progresses, in accordance with the requirements of this Section E.2. Applications for payment shall be based upon estimates of Work completed and the Schedule of Values. As a condition precedent to Owner's obligation to pay, all applications for payment shall be approved by the Owner. A progress payment shall not be considered acceptance or approval of any Work or waiver of any defects therein. Owner shall pay to Contractor interest for overdue invoices at the rate of two-thirds of one percent per month on the progress payment, not including retainage, due the Contractor. Overdue invoices will be those that have not been paid within forty five (45) days from the latest of:

- (a) The date of the receipt of the accurate invoice;
- (b) The date Owner receives the correct application for payment if no invoice is received;
- (c) The date all goods and services have been received; or
- (d) The date a Claim is made certain by agreement of the parties or by operation of law.

Notwithstanding the foregoing, in instances when an application for payment is filled out incorrectly, or when there is any defect or impropriety in any submitted application or when there is a good faith dispute, Owner shall so notify the Contractor within fifteen (15) Days stating the reason or reasons the application for payment is defective or improper or the reasons for the dispute. A defective or improper application for payment, if corrected by the Contractor within seven (7) Days of being notified by the Owner, shall not cause a payment to be made later than specified in this section unless interest is also paid. Payment of interest will be postponed when payment on the principal is delayed because of disagreement between the Owner and the Contractor.

Owner reserves the right, instead of requiring the Contractor to correct or resubmit a defective or improper application for payment, to reject the defective or improper portion of the application for payment and pay the remainder of the application for such amounts which are correct and proper.

Owner, upon written notice to the Contractor, may elect to make payments to the Contractor only by means of Electronic Funds

Transfers (EFT) through Automated Clearing House (ACH) payments. If Owner makes this election, the Contractor shall arrange for receipt of the EFT/ACH payments.

E.2.2 Contractor shall submit to the Owner an application for each payment and, if required, receipts or other vouchers showing payments for materials and labor including payments to Subcontractors. Contractor shall include in its application for payment a schedule of the percentages of the various parts of the Work completed, based on the Schedule of Values which shall aggregate to the payment application total, and shall include, on the face of each copy thereof, a certificate in substantially the following form:

"I, the undersigned, hereby certify that the above bill is true and correct, and the payment therefore, has not been received.

Signed: _____
Dated: _____"

E.2.3 Generally, applications for payment will be accepted only for materials that have been installed. Under special conditions, applications for payment for stored materials will be accepted at Owner's sole discretion. Such a payment, if made, will be subject to the following conditions:

- (a) The request for stored material shall be submitted at least thirty (30) Days in advance of the application for payment on which it appears. Applications for payment shall be entertained for major equipment, components or expenditures only.
- (b) The Contractor shall submit applications for payment showing the quantity and cost of the material stored.
- (c) The material shall be stored in a bonded warehouse and Owner shall be granted the right to access the material for the purpose of removal or inspection at any time during the Contract Period.
- (d) The Contractor shall name the Owner as co-insured on the insurance policy covering the full value of the property while in the care and custody of the Contractor until it is installed. A certificate noting this coverage shall be issued to the Owner.
- (e) Payments shall be made for materials and equipment only. The submitted amount in the application for payment shall be reduced by the cost of transportation from the storage site to the project site and for the cost of an inspector to verify delivery and condition of the goods at the storage site. The cost of storage and inspection shall be borne solely by the Contractor.
- (f) Within sixty (60) Days of the application for payment, the Contractor shall submit evidence of payment covering the material and/or equipment stored and of payment for the storage site.
- (g) Payment for stored materials and/or equipment shall in no way indicate acceptance of the materials and/or equipment or waive any rights under this Contract for the rejection of the Work or materials and/or equipment not in conformance with the Contract Documents.
- (h) All required documentation shall be submitted with the respective application for payment.

E.2.4 The Owner reserves the right to withhold all or part of a payment, or may nullify in whole or part any payment previously made, to such extent as may be necessary in the Owner's opinion to protect the Owner from loss because of:

- (a) Work that is defective and not remedied, or that has been demonstrated or identified as failing to conform with Applicable Laws or the Contract Documents,
- (b) Third party claims filed or evidence reasonably indicating that such claims will likely be filed unless security acceptable to the Owner is provided by the Contractor;
- (c) Failure of the Contractor to make payments properly to Subcontractors or for labor, materials or equipment (in which case Owner may issue checks made payable jointly to Contractor and such unpaid persons under this provision, or directly to Subcontractors and suppliers at any level under Section C.3.2.);
- (d) Reasonable evidence that the Work cannot be completed for the unpaid balance of the Contract Price;
- (e) Damage to the Work, Owner or another contractor;
- (f) Reasonable evidence that the Work will not be completed within the Contract Time required by the Contract, and that the unpaid balance would not be adequate to cover actual or liquidated damages for the anticipated delay;
- (g) Failure to carry out the Work in accordance with the Contract Documents; or
- (h) Assessment of liquidated damages, when withholding is made for offset purposes.

E.2.5 Subject to the provisions of the Contract Documents, the amount of each progress payment shall be computed as follows:

- (a) Take that portion of the Contract Price properly allocable to completed Work as determined by multiplying the percentage completion of each portion of the Work by the share of the total Contract Price allocated to that portion of the Work in the Schedule of Values, less retainage as provided in Section E.5. Pending final determination of cost to the Owner of changes in the Work, no amounts for changes in the Work can be included in applications for payment until the Contract Price has been adjusted by a Supplement Amendment;
- (b) Add that portion of the Contract Price properly allocable to materials and equipment delivered and suitably stored at the site for subsequent incorporation in the completed construction (or, if approved in advance by the Owner pursuant to Section E.2.3, suitably stored off the site at a location agreed upon in writing), less retainage as provided in Section E.5;
- (c) Subtract the aggregate of previous payments made by the Owner; and
- (d) Subtract any amounts for which the Owner has withheld or nullified payment as provided in the Contract Documents.

E.2.6 Contractor's applications for payment shall not include requests for payment for portions of the Work for which the Contractor does not intend to pay to a Subcontractor or material supplier.

E.2.7 The Contractor warrants to Owner that title to all Work covered by an application for payment will pass to the Owner no later than the time of payment. The Contractor further warrants that upon submittal of an application for payment all Work for which payments are received from the Owner shall be free and clear of liens, claims, security interests or encumbrances in favor of the Contractor, Subcontractors, material suppliers, or other persons or entities making a claim by reason of having provided financing, labor, materials and equipment relating to the Work.

E.2.8 If Contractor disputes any determination by Owner with regard to any application for payment, Contractor nevertheless shall continue to expeditiously perform the Work. No payment made hereunder shall be or be construed to be final acceptance or approval of that portion of the Work to which such partial payment relates or shall relieve Contractor of any of its obligations hereunder.

E.2.9 Contractor shall submit its initial MWESB Report within ten (10) Days of Contractor's execution of the Contract. Contractor shall submit annual MWESB Reports on June 30 of each year the Contract is active. Contracts first executed by Contractor within ninety (90) Days before June 30 of the year of execution by Contractor may at the discretion of Owner be exempt from submitting the annual MWESB Report otherwise due on that June 30. The final MWESB Report shall be filed with the application for final payment. Timely receipt of MWESB Reports by Owner shall be a condition precedent to Owner's obligation to pay any progress payments or final payment otherwise due.

E.3 PAYROLL CERTIFICATION REQUIREMENT

Owner's receipt of payroll certification pursuant to Section C.2 of this Contract shall be a condition precedent to Owner's obligation to pay any progress payments or final payment otherwise due.

E.4 DUAL PAYMENT SOURCES

Contractor shall not be compensated for Work performed under this Contract from any state agency other than the agency that is a party to this Contract.

E.5 RETAINAGE

E.5.1 Retainage shall be withheld and released in accordance with the requirements set forth in OSU Standards.

E.5.1.1 Owner may reserve as retainage from any progress payment an amount not to exceed five percent of the payment. As Work progresses, Owner may reduce the amount of retainage on or may eliminate retainage on any remaining monthly Contract payments after 50 percent of the Work under the Contract is completed if, in the Owner's discretion, such Work is progressing satisfactorily. Elimination or reduction of retainage shall be allowed only at Owner's sole discretion and only upon written application by the Contractor, which application shall include written approval of Contractor's surety; except that when the Work is 97-1/2 percent completed the Owner may, at its discretion and without application by the Contractor, reduce the retained amount to 100 percent of the value of the Work remaining to be done. Upon receipt of written application by the Contractor, Owner shall respond in writing within a reasonable time.

E.5.1.2 Contractor may request in writing:

- (a) To be paid amounts which would otherwise have been retained from progress payments where Contractor has deposited acceptable bonds and securities of equal value with Owner or in a custodial account or other mutually-agreed account satisfactory to Owner, with an approved bank or trust company to be held in lieu of the cash retainage for the benefit of Owner;
- (b) For construction projects over \$1,000,000, that retainage be deposited in an interest bearing account, established through the State Treasurer for state agencies, in a bank, savings bank, trust company or savings association for the benefit of Owner, with earnings from such account accruing to the Contractor; or

- (c) That the Owner allow Contractor to deposit a surety bond for the benefit of Owner, in a form acceptable to Owner, in lieu of all or a portion of funds retained, or to be retained. Such bond and any proceeds therefrom shall be made subject to all claims in the manner and priority as set forth for retainage.

When the Owner has accepted the Contractor's election of option (a) or (b), Owner may recover from Contractor any additional costs incurred through such election by reducing Contractor's final payment. Where the Owner has agreed to Contractor's request for option (c), Contractor shall accept like bonds from Subcontractors and suppliers on the project from which Contractor has required retainages.

E.5.1.3 The retainage held by Owner shall be included in and paid to the Contractor as part of the Final Payment of the Contract Price. The Owner shall pay to Contractor interest at the rate of two-thirds of one percent per month on the final payment due Contractor, interest to commence forty five (45) Days after the date which Owner receives Contractor's final approved application for payment and Work under the Contract has been completed and accepted and to run until the date when final payment is tendered to Contractor. The Contractor shall notify Owner in writing when the Contractor considers the Work complete and deliver to Owner its final application for payment and Owner shall, within fifteen (15) Days after receiving the written notice and the application for payment, either accept the Work or notify the Contractor of Work yet to be performed on the Contract. If Owner does not within the time allowed notify the Contractor of Work yet to be performed to fulfill contractual obligations, the interest provided by this subsection shall commence to run forty five (45) Days after the end of the 15-Day period.

E.5.1.4 Owner will reduce the amount of the retainage if the Contractor notifies the controller of the Owner that the Contractor has deposited in an escrow account with a bank or trust company, in a manner authorized by the Owner, bonds and securities of equal value of a kind approved by the Owner and such bonds and securities have in fact been deposited.

E.5.1.5 Contractor agrees that if Contractor elects to reserve a retainage from any progress payment due to any Subcontractor or supplier, such retainage shall not exceed five percent of the payment, and such retainage withheld from Subcontractors and suppliers shall be subject to the same terms and conditions stated in Subsection E.5 as apply to Owner's retainage from any progress payment due to Contractor.

E.6 FINAL PAYMENT

E.6.1 Upon completion of all the Work under this Contract, the Contractor shall notify the Owner, in writing, that Contractor has completed Contractor's obligations under the Contract and shall prepare its application requesting final payment. Upon receipt of such notice and application for payment, the Owner will inspect the Work, and, if acceptable, submit to the Owner a recommendation as to acceptance of the completed Work and the final estimate of the amount due the Contractor. If the Work is not acceptable, Owner will notify Contractor within fifteen (15) Days of Contractor's request for Final Payment. Upon approval of this final application for payment by the Owner and compliance by the Contractor with provisions in Section K, and Contractor's satisfaction of other provisions of the Contract Documents as may be applicable, the Owner shall pay to the Contractor all monies due under the provisions of these Contract Documents.

E.6.2 Neither Final Payment nor any remaining retained percentage shall become due until the Contractor submits to the Owner (1) a certificate evidencing that insurance required by the Contract

Documents to remain in force after Final Payment is currently in effect and will not be canceled or allowed to expire until at least thirty (30) Days' prior written notice has been given to the Owner, (2) a written statement that the Contractor knows of no substantial reason that the insurance will not be renewable to cover the period required by the Contract Documents, (3) consent of surety, if any, to Final Payment and (4), if required by the Owner, other data establishing payment or satisfaction of obligations, such as receipts, releases and waivers of liens, claims, security interests or encumbrances arising out of the Contract, to the extent and in such form as may be designated by the Owner. If a Subcontractor refuses to furnish a release or waiver required by the Owner, the Contractor may furnish a bond satisfactory to the Owner to indemnify the Owner against such lien. If such lien remains unsatisfied after payments are made, the Contractor shall refund to the Owner all money that the Owner may be compelled to pay in discharging such lien, including all costs and reasonable attorneys' fees.

E.6.3 Acceptance of Final Payment by the Contractor, a Subcontractor or material supplier shall constitute a waiver of claims by that payee except those previously made in writing and identified by that payee as unsettled at the time of final application for payment.

E.6.4 Contractor agrees to submit its final payment application within ninety (90) Days after Substantial Completion, unless written extension is granted by Owner. Contractor shall not delay Final Payment application for any reason, including without limitation nonpayment of Subcontractors, suppliers, manufacturers or others not a party to this Contract, or lack of resolution of a dispute with Owner or any other person of matters arising out of or relating to the Contract. If Contractor fails to submit its Final Payment application within ninety (90) Days after Substantial Completion, and Contractor has not obtained written extension by Owner, all requests or Claims for additional costs or an extension of Contract Time shall be waived.

SECTION F JOB SITE CONDITIONS

F.1 USE OF PREMISES

Contractor shall confine equipment, storage of materials and operation of Work to the limits indicated by Contract Documents, Applicable Laws, permits or directions of the Owner. Contractor shall follow the Owner's instructions regarding use of premises, if any.

F.2 PROTECTION OF WORKERS, PROPERTY AND THE PUBLIC

F.2.1 Contractor shall maintain continuous and adequate protection of all of the Work from damage and shall protect the Owner, workers and property from injury or loss arising in connection with this Contract. Contractor shall remedy acceptably to the Owner any damage, injury, or loss, except such as may be directly due to errors in the Contract Documents or caused by authorized representatives or personnel of the Owner. Contractor shall adequately protect adjacent property as provided by law and the Contract Documents.

F.2.2 Contractor shall take all necessary precautions for the safety of all personnel on the job site or otherwise engaged in the undertaking of the Work and shall comply with the Contract Documents, best practices and all applicable provisions of federal, state and municipal safety laws and building codes to prevent accidents or injury to persons on, about or adjacent to the premises where the Work is being performed. Contractor shall erect and properly maintain at all times, as required by the conditions and progress of the Work, all necessary safeguards for protection of workers and the public against any hazards created by construction. Contractor shall designate a responsible employee or associate on the Work site, whose duty shall be the

prevention of accidents. The name and position of the person designated shall be reported to the Owner. The Owner has no responsibility for Work site safety. Work site safety shall be the responsibility of the Contractor.

F.2.3 Contractor shall not enter upon private property without first obtaining permission from the property owner or its duly authorized representative. Contractor shall be responsible for the preservation of all public and private property along and adjacent to the Work contemplated under the Contract and shall use every precaution necessary to prevent damage thereto. In the event the Contractor damages any property, the Contractor shall at once notify the property owner and make, or arrange to make, full restitution. Contractor shall, immediately and in writing, report to the Owner, all pertinent facts relating to such property damage and the ultimate disposition of the claim for damage.

F.2.4 Contractor shall be responsible for protection of adjacent work areas including impacts brought about by activities, equipment, labor, utilities, vehicles and materials on the site.

F.2.5 Contractor shall at all times direct its activities in such a manner as to minimize adverse effects on the environment. Handling of all materials shall be conducted so no release will occur that may pollute or become hazardous.

F.2.6 In an emergency affecting the safety of life or limb or of the Work or of adjoining property, the Contractor, without special instruction or authorization from the Owner, shall act reasonably to prevent threatened loss or injury, and shall so act, without appeal, if instructed by the Owner. Any compensation claimed by the Contractor on account of emergency work shall be determined in accordance with section D.

F.3 CUTTING AND PATCHING

F.3.1 Contractor shall be responsible for coordinating all cutting, fitting, or patching of the Work to make its several parts come together properly and fit to receive or be received by work of other contractors or Subcontractors shown upon, or reasonably implied by, the Contract Documents.

F.3.2 Contractor shall be responsible for restoring all cut, fitted, or patched surfaces to an original condition; provided, however, that if a different condition is specified in the Contract Documents, then Contractor shall be responsible for restoring such surfaces to the condition specified in the Contract Documents.

F.4 CLEANING UP

From time to time as may be prudent or ordered by the Owner and, in any event, immediately after completion of the Work, the Contractor shall, at its own expense, clean up and remove all refuse and unused materials of any kind resulting from the Work. If Contractor fails to do so within twenty-four hours after notification by the Owner the work may be done by others and the cost charged to the Contractor and deducted from payment due the Contractor.

F.5 ENVIRONMENTAL CONTAMINATION

F.5.1. Contractor shall be held responsible for and shall indemnify, defend (with counsel of Owner's choice), and hold harmless Owner from and against any costs, expenses, damages, claims, and causes of action, (including attorney fees), or any of them, resulting from all spills, releases, discharges, leaks and disposal of environmental pollution, including storage, transportation, and handling during the performance of the Work or Contractor's obligations under the Contract which occur as a result of, or are contributed by, the negligence or actions of Contractor or its personnel, agents, or Subcontractors or any failure to perform in accordance with the Contract Documents

(except to the extent otherwise void under ORS 30.140). Nothing in this section F.5.1 shall limit Contractor's responsibility for obtaining insurance coverages required under Section G.3 of this Contract, and Contractor shall take no action that would void or impair such coverages.

F.5.1.1 Contractor agrees to promptly dispose of such spills, releases, discharge or leaks to the satisfaction of Owner and regulatory agencies having jurisdiction in a manner that complies with Applicable Laws. Cleanup shall be at no cost to the Owner and shall be performed by properly qualified and, if applicable, licensed personnel.

F.5.1.2 Contractor shall obtain the Owner's written consent prior to bringing onto the Work site any (i) environmental pollutants or (ii) hazardous substances or materials, as the same or reasonably similar terms are used in any Applicable Laws. Notwithstanding such written consent from the Owner, the Contractor, at all times, shall:

- (a) Properly handle, use and dispose of all environmental pollutants and hazardous substances or materials brought onto the Work site, in accordance with all Applicable Laws;
- (b) Be responsible for any and all spills, releases, discharges, or leaks of (or from) environmental pollutants or hazardous substances or materials which Contractor has brought onto the Work site; and
- (c) Promptly clean up and remediate, without cost to the Owner, such spills, releases, discharges, or leaks to the Owner's satisfaction and in compliance with all Applicable Laws.

F.5.2 Contractor shall report all reportable quantity releases, as such releases are defined in Applicable Laws, including but not limited to 40 CFR Part 302, Table 302.4 and in OAR 340-142-0050, to applicable federal, state, and local regulatory and emergency response agencies. Upon discovery, regardless of quantity, Contractor must telephonically report all releases to the Owner. A written follow-up report shall be submitted to Owner within 48 hours of the telephonic report. Such written report shall contain, as a minimum:

- (a) Description of items released (identity, quantity, manifest numbers, and any and all other documentation required by law.)
- (b) Whether amount of items released is EPA/DEQ reportable, and, if so, when reported.
- (c) Exact time and location of release, including a description of the area involved.
- (d) Containment procedures initiated.
- (e) Summary of communications about the release between Contractor and members of the press or State, local or federal officials other than Owner.
- (f) Description of cleanup procedures employed or to be employed at the site, including disposal location of spill residue.
- (g) Personal injuries, if any, resulting from, or aggravated by, the release.

F.6 ENVIRONMENTAL CLEAN-UP

F.6.1 Unless disposition of environmental pollution is specifically a part of this Contract, or was caused by the Contractor (reference

F.5 Environmental Contamination), Contractor shall immediately notify Owner of any hazardous substance(s) which Contractor discovers or encounters during performance of the Work required by this Contract. "Hazardous substance(s)" means any hazardous, toxic and radioactive materials and those substances defined as "hazardous substances," "hazardous materials," "hazardous wastes," "toxic substances," or other similar designations in any federal, state, or local law, regulation, or ordinance, including without limitation asbestos, polychlorinated biphenyl (PCB), or petroleum, and any substances, materials or wastes regulated by 40 CFR, Part 261 and defined as hazardous in 40 CFR S 261.3. In addition to notifying Owner of any hazardous substance(s) discovered or encountered, Contractor shall immediately cease working in any particular area of the project where a hazardous substance(s) has been discovered or encountered if continued work in such area would present a risk or danger to the health or well-being of Contractor's or any Subcontractor's work force, property or the environment.

F.6.2 Upon being notified by Contractor of the presence of hazardous substance(s) on the project site, Owner shall arrange for the proper disposition of such hazardous substance(s).

F.7 FORCE MAJEURE

A party to this Contract shall not be held responsible for delay or default due to Force Majeure acts, events or occurrences unless they could have been avoided by the exercise of reasonable care, prudence, foresight, and diligence by that party. The Owner may terminate this Contract upon written notice after determining that delay or default caused by Force Majeure acts, events or occurrences will reasonably prevent successful performance of the Contract.

SECTION G INDEMNITY, BONDING, AND INSURANCE

G.1 RESPONSIBILITY FOR DAMAGES / INDEMNITY

G.1.1 Contractor shall be responsible for all damage to property, injury to persons, and loss, expense, inconvenience, and delay that may be caused by, or result from, the carrying out of the Work to be done under this Contract, or from any act, omission or neglect of the Contractor, its Subcontractors, sub-subcontractors of any tier, suppliers, employees, guests, visitors, invitees and agents.

G.1.2 To the fullest extent permitted by law, Contractor shall indemnify, defend (with counsel approved by Owner) and hold harmless the Owner, Architect/Engineer, Architect/Engineer's consultants, and their respective officers, directors, agents, employees, partners, members, stockholders and affiliated companies (collectively "Indemnitees") from and against all liabilities, damages, losses, claims, expenses (including reasonable attorney fees), demands and actions of any nature whatsoever which arise out of, result from or are related to, (a) any damage, injury, loss, expense, inconvenience or delay described in this Section G.1., (b) any accident or occurrence which happens or is alleged to have happened in or about the project site or any place where the Work is being performed, or in the vicinity of either, at any time prior to the time the Work is fully completed in all respects, (c) any failure of the Contractor or its Subcontractors, sub-subcontractors of any tier, suppliers, employees or consultants to observe or perform any duty or obligation under the Contract Documents which is to be observed or performed by the Contractor, or any breach of any agreement, representation or warranty of the Contractor contained in the Contract Documents or in any subcontract, (d) the negligent acts or omissions of the Contractor, a Subcontractor, sub-subcontractor of any tier suppliers, a consultant or anyone directly or indirectly employed by them or any one of them or anyone for whose acts they may be liable, regardless of whether or not such claim, damage, loss or expense

is caused in part by a party indemnified hereunder (except to the extent otherwise void under ORS 30.140), and (e) any lien filed upon the project or bond claim in connection with the Work. Such obligation shall not be construed to negate, abridge, or reduce other rights or obligations of indemnity which would otherwise exist as to a party or person described in this Section G.1.2.

G.1.3 In claims against any person or entity indemnified under Section G.1.2 by an employee of the Contractor, a Subcontractor, anyone directly or indirectly employed by them or anyone for whose acts they may be liable, the indemnification obligation under Section G.1.2 shall not be limited by a limitation on amount or type of damages, compensation or benefits payable by or for the Contractor or a Subcontractor under workers' compensation acts, disability benefit acts or other employee benefit acts.

G.2 PERFORMANCE AND PAYMENT SECURITY; PUBLIC WORKS BOND

G.2.1 When the Contract Price is \$150,000 or more (or \$50,000 or more in the case of Contracts for highways, bridges and other transportation projects), the Contractor shall furnish and maintain in effect at all times during the Contract Period a performance bond in a sum equal to the Contract Price and a separate payment bond also in a sum equal to the Contract Price. Contractor shall furnish such bonds even if the Contract Price is less than the above thresholds if otherwise required by the Contract Documents.

G.2.2 Bond forms furnished by the Owner and notarized by awarded Contractor's surety company authorized to do business in Oregon are the only acceptable forms of performance and payment security, unless otherwise specified in the Contract Documents.

G.2.3 Before execution of the Contract the Contractor shall file with the Construction Contractors Board, and maintain in full force and effect, the separate public works bond required by ORS Chapter 279C, and OAR 839-025-0015, unless otherwise exempt under those provisions. The Contractor shall also include in every subcontract a provision requiring the Subcontractor to have a public works bond filed with the Construction Contractors Board before starting Work, unless otherwise exempt, and shall verify that the Subcontractor has filed a public works bond before permitting any Subcontractor to start Work.

G.3 INSURANCE

G.3.1 General Requirements. The required insurance amounts set forth below do not in any way limit the amount or scope of liability of Contractor under this Contract. The amounts listed indicate only the minimum amounts of insurance coverage Owner is willing to accept to help insure full performance of all terms and conditions of this Contract.

G.3.1.1 Primary Coverage: Insurance carried by Contractor under this Contract shall be the primary and non-contributory coverage. The coverages indicated are minimums unless otherwise specified in the Contract Documents.

G.3.1.2 Company Ratings. All policies of insurance must be written by companies having an A.M. Best rating of no less than "A-VII", or equivalent. Owner may, upon thirty (30) days written notice to Contractor, require Contractor to change any carrier whose rating drops below an "A-VII" rating. Eligible insurers include admitted insurers that have been issued a certificate of authority from the Oregon Department of Consumer and Business Services authorizing them to conduct an insurance business and issue policies of insurance in the state of Oregon, and certain non-admitted surplus lines insurers that satisfy the

requirements of applicable Oregon law and which are subject to approval the Owner.

G.3.1.3 Additional Insured: Each liability policy, except for Worker's Compensation, shall be endorsed to include Owner, its officers, trustees, employees and agents as additional insured but only with respect to the Contractor's activities to be performed under this Contract.

If Contractor cannot obtain an insurer to name the Owner as additional insured, Contractor shall obtain at Contractor's expense, and keep in effect during the term of this Contract, Owners and Contractors Protective Liability Insurance, naming the Owner as additional insured with minimum limits of \$2,000,000 per occurrence and \$2,000,000 aggregate. This policy must be kept in effect for 36 months following Final Completion. As evidence of coverage, Contractor shall furnish the actual policy to Owner prior to execution of the Contract.

G.3.1.4 Notice of Cancellation or Change: If the Contractor receives a non-renewal or cancellation notice from an insurance carrier affording coverage required herein, or receives notice that coverage no longer complies with the insurance requirements herein, Contractor agrees to notify Owner by fax within five (5) business days with a copy of the non-renewal or cancellation notice, or written specifics as to which coverage is no longer in compliance. When notified by Owner, the Contractor agrees to stop Work pursuant to this Contract, unless all required insurance remain in effect. Any failure to comply with the reporting provisions of this insurance, except for the potential exhaustion of aggregate limits, shall not affect the coverages provided to the Owner.

Owner shall have the right, but not the obligation, of prohibiting Contractor from entering the Work site until a new certificate(s) of insurance is provided to Owner evidencing the replacement coverage. The Contractor agrees Owner reserves the right to withhold payment to Contractor until evidence of reinstated or replacement coverage is provided to Owner.

G.3.2 Workers' Compensation: All employers, including Contractor, that employ subject workers who work under this Contract in the State of Oregon shall comply with ORS 656.017 and provide the required Workers' Compensation coverage, unless such employers are exempt under ORS 656.126. This shall include Employer's Liability Insurance with minimum limits of \$1,000,000 each accident; \$1,000,000 disease-each employee; and \$1,000,000 disease-policy limit. Contractors who perform the Work without the assistance or labor of any employee need not obtain such coverage if the Contractor certifies so in writing. Contractor shall ensure that each of its Subcontractors complies with these requirements. The Contractor shall require proof of such Workers' Compensation coverage by receiving and keeping on file a certificate of insurance from each Subcontractor or anyone else directly employed by either the Contractor or its Subcontractors.

G.3.3 Commercial General Liability. Contractor shall obtain, and keep in effect at Contractor's expense for the term of the Contract, Commercial General Liability Insurance covering bodily injury and property damage in the minimum amount of \$2,000,000 per occurrence and \$4,000,000 aggregate. This insurance shall include personal injury liability, products and completed operations, and contractual liability for the indemnities provided under this Contract (to the extent contractual liability coverage for the indemnity is available in the marketplace).

G.3.4. Automobile Liability: Contractor shall obtain, at Contractor's expense, and keep in effect during the term of this Contract, Automobile Liability Insurance with "symbol 1" coverage (owned, hired, and non-owned vehicles). The coverage may

be written in combination with the Commercial General Liability Insurance. Contractor shall provide proof of insurance showing minimum limits of \$2,000,000 combined single limit. Contractor and its Subcontractors shall be responsible for ensuring that all non-owned vehicles maintain adequate Automobile Liability insurance while on site. If the scope of services in this Contract requires the transportation of any hazardous material or regulated substances, the policy shall include a CA 9948 endorsement or its equivalent and MCS-90 to provide coverage for claims resulting in bodily injury, property damage or cleanup costs associated with a pollution condition from transported cargo.

G.3.5 Owner may adjust the insurance amounts required in Section G.3.3 and G.3.4 through the issuance of Supplemental General Conditions.

G.3.6 Pollution Liability. When required by Supplemental General Conditions, Contractor shall obtain, at Contractor's expense, and keep in effect during the term of this Contract, Pollution liability Insurance in minimum amounts of \$3,000,000 per occurrence and \$3,000,000 aggregate, naming Owner as additional insured as noted in the Additional Insured section.

G.3.7 Certificate(s) of Insurance: As evidence of the insurance coverage required by this Contract, the Contractor shall furnish certificate(s) of insurance to the Owner prior to execution of the Contract. The certificate(s) will specify all of the parties who are additional insureds for this contract, and the applicable endorsements will be attached. Additional insured endorsements must include completed operations without restriction to contractual requirements.

G.3.8 Subcontractors. Subject to and following the written approval of the Owner as outlined in B.11.3 as related to Subcontracts and Assignment, the Contractor shall require Subcontractors to have insurance as outlined in section G.3.1 through G.3.4; however, the policy limits may be reduced, but no case shall the policy limits be less than \$1,000,000.

SECTION H SCHEDULE OF WORK

H.1 CONTRACT PERIOD

H.1.1 Time is of the essence. The Contractor shall at all times carry on the Work diligently, without delay and punctually fulfill all requirements herein. If required by the Contract Documents, Contractor shall commence Work on the site within fifteen (15) Days of Notice to Proceed, unless directed otherwise.

H.1.2 Unless specifically extended by Supplement Amendment, all Work shall be complete by the date contained in the Contract Documents. The Owner shall have the right to accelerate the completion date of the Work, which may require the use of overtime. Such accelerated Work schedule shall be an acceleration in performance of Work under Section D.1.2 (f) and shall be subject to the provisions of Section D.1.

H.1.3 The Owner shall not waive any rights under the Contract by permitting the Contractor to continue or complete in whole or in part the Work after the date described in Section H.1.2 above.

H.2 SCHEDULE

H.2.1 Contractor shall provide, by or before the pre-construction conference, the initial as-planned Construction Schedule for review and acceptance by the Owner. The submitted Construction Schedule must illustrate Work by project components, labor trades, and long lead items broken down by building and/or floor where applicable. If Owner shall so elect, Contractor shall provide the schedule in CPM format showing

the graphical network of planned activities, including i) a reasonably detailed list of all activities required to complete the Work; ii) the time and duration that each activity will take to completion; and iii) the dependencies between the activities. Construction Schedules lacking adequate detail, or unreasonably detailed, will be rejected. The Construction Schedule shall include the following: Notice to Proceed or the date the Work commences, if no Notice to Proceed is issued by Owner, Substantial Completion, and Final Completion. Schedules shall be updated monthly, unless otherwise required by the Contract Documents, and submitted with the monthly application for payment. Acceptance of the Construction Schedule by the Owner does not constitute agreement by the Owner as to the Contractor's sequencing, means, methods, or durations. Any positive difference between the Contractor's scheduled completion and the Contract completion date is float owned by the Owner. Owner reserves the right to negotiate the float if it is deemed to be in Owner's best interest to do so. In no case shall the Contractor make a claim for delays if the Work is completed within the Contract Time but after Contractor's scheduled completion.

H.3 PARTIAL OCCUPANCY OR USE

H.3.1 The Owner may occupy or use any completed or partially completed portion of the Work at any stage, provided such occupancy or use is consented to by public authorities having jurisdiction over the Work. Such partial occupancy or use may commence whether or not the portion is substantially complete, provided the Owner and Contractor have reasonably accepted in writing the responsibilities assigned to each of them for payments, retainage, if any, security, insurance or self-insurance, maintenance, heat, utilities, and damage to the Work, and have agreed in writing concerning the period for correction of the Work and commencement of warranties required by the Contract Documents with respect to such portion of the Work. Approval by the Contractor to partial occupancy or use shall not be unreasonably withheld. Immediately prior to such partial occupancy or use, the Owner and Contractor shall jointly inspect the area to be occupied or portion of the Work to be used in order to determine and record the condition of the Work. Partial occupancy or use of a portion or portions of the Work shall not constitute acceptance of Work not complying with the requirements of the Contract Documents.

SECTION I CORRECTION OF WORK

I.1 CORRECTION OF WORK BEFORE FINAL PAYMENT

The Contractor warrants to the Owner that materials and equipment furnished under the Contract will be of good quality and new unless otherwise required or permitted by the Contract Documents, that the Work will be free from defects, and that the Work will conform to the requirements of the Contract Documents. Work failing to conform to these requirements shall be deemed defective. Contractor shall promptly remove from the premises and replace all defective materials and equipment as determined by the Owner, whether incorporated in the Work or not. Removal and replacement shall be without loss or expense to the Owner, and Contractor shall bear the cost of repairing all Work destroyed or damaged by such removal or replacement. Contractor shall be allowed a period of no longer than thirty (30) Days after Substantial Completion for completion of defective (Punch List) work. At the end of the thirty-day period, or earlier if requested by the Contractor, Owner shall arrange for inspection of the Work by the Architect/Engineer. Should the work not be complete, and all corrections made, the costs for all subsequent re-inspections shall be borne by the Contractor. If Contractor fails to complete the Punch List work within the thirty (30) Day period, Owner may perform such work and Contractor shall reimburse Owner all costs of the same within ten (10) Days after demand without affecting Contractor's obligations.

I.2 WARRANTY WORK

I.2.1 Neither the final certificate of payment nor any provision of the Contract Documents shall relieve the Contractor from responsibility for defective Work and, unless a longer period is specified, Contractor shall correct all defects that appear in the Work within a period of one year from the date of issuance of the written notice of Substantial Completion by the Owner except for latent defects which will be remedied by the Contractor at any time they become apparent. The Owner shall give Contractor notice of defects with reasonable promptness. The Contractor shall perform the warranty Work by correcting defects within twenty-four (24) hours of notification by Owner, unless otherwise specified in the Contract Documents. Should the Contractor fail to respond within the specified response time, the Owner may, at its option, complete the necessary repairs using another contractor or its own forces. If Owner completes the repairs using Owner's own forces, Contractor shall pay Owner at the rate of one and one-half (1½) times the standard hourly rate of Owner's forces, plus related overhead and any direct non-salary costs. If Owner completes the repairs using another contractor, Contractor shall pay Owner the amount of Owner's direct costs billed by the other contractor for the work, plus the direct salary costs and related overhead and direct non-salary expenses of Owner's forces who are required to monitor that contractor's work. Work performed by Owner using Owner's own forces or those of another contractor shall not affect the Contractor's contractual duties under these provisions, including warranty provisions. In the event of warranty work consisting of emergency repairs, Owner may perform such work and Contractor shall reimburse Owner all costs of the same within ten (10) Days after demand, without affecting Contractor's obligations.

I.2.2 Nothing in this Section I.2 provision shall negate guarantees or warranties for periods longer than one year including without limitation such guarantees or warranties required by other sections of the Contract Documents for specific installations, materials, processes, equipment or fixtures.

I.2.3 In addition to Contractor's warranty, manufacturer's warranties shall pass to the Owner and shall not take effect until such portion of the Work covered by the applicable warranty has been accepted in writing by the Owner.

I.2.4 The one-year period for correction of Work shall be extended with respect to portions of Work performed after Substantial Completion by the period of time between Substantial Completion and the actual performance of the Work, and shall be extended by corrective Work performed by the Contractor pursuant to this Section, as to the Work corrected. The Contractor shall remove from the site portions of the Work which are not in accordance with the requirements of the Contract Documents and are neither corrected by the Contractor nor accepted by the Owner.

I.2.5 Nothing contained in this Section I.2 shall be construed to establish a period of limitation with respect to other obligations which the Contractor might have under the Contract Documents. Establishment of the period for correction of Work as described in this Section I.2 relates only to the specific obligation of the Contractor to correct the Work, and has no relationship to the time within which the obligation to comply with the Contract Documents may be sought to be enforced, nor to the time within which proceedings may be commenced to establish the Contractor's liability with respect to the Contractor's obligations other than specifically to correct the Work.

I.2.6 If the Owner prefers to accept Work which is not in accordance with the requirements of the Contract Documents, the Owner may do so instead of requiring its removal and correction, in which case the Contract Price will be reduced as appropriate and

equitable. Such adjustment shall be effected whether or not final payment has been made.

estate fails to assume the Contract within a reasonable time;

SECTION J SUSPENSION AND/OR TERMINATION OF THE WORK

J.1 OWNER'S RIGHT TO SUSPEND THE WORK

J.1.1 The Owner has the authority to suspend portions or all of the Work due to the following causes:

- (a) Failure of the Contractor to correct unsafe conditions;
- (b) Failure of the Contractor to carry out any provision of the Contract;
- (c) Failure of the Contractor to carry out orders;
- (d) Conditions, in the opinion of the Owner, which are unsuitable for performing the Work;
- (e) Time required to investigate differing site conditions;
- (f) Any reason considered to be in the public interest.

J.1.2 The Owner shall notify Contractor and the Contractor's Surety in writing of the effective date and time of the suspension, and Owner shall notify Contractor and Contractor's surety in writing to resume Work.

J.2 CONTRACTOR'S RESPONSIBILITIES

J.2.1 During the period of the suspension, Contractor is responsible to continue maintenance at the project just as if the Work were in progress. This includes, but is not limited to, protection of completed Work, maintenance of access, protection of stored materials, temporary facilities, and clean-up.

J.2.2 When the Work is recommenced after the suspension, the Contractor shall replace or renew any Work damaged during the suspension, remove any materials or facilities used as part of temporary maintenance, and complete the project in every respect as though its prosecution had been continuous and without suspension.

J.3 COMPENSATION FOR SUSPENSION

J.3.1 Depending on the reason for suspension of the Work, the Contractor or the Owner may be due compensation by the other party. If the suspension was required due to acts or omissions of Contractor, the Owner may assess the Contractor actual costs of the suspension in terms of administration, remedial work by the Owner's forces or another contractor to correct the problem associated with the suspension, rent of temporary facilities, and other actual costs related to the suspension. If the suspension was caused by acts or omissions of the Owner, the Contractor may be due compensation which shall be defined using Section D, Changes in Work. If the suspension was required through no fault of the Contractor or the Owner, neither party shall owe the other for the impact.

J.4 OWNER'S RIGHT TO TERMINATE CONTRACT

J.4.1 The Owner may, without prejudice to any other right or remedy, and after giving Contractor seven (7) Days' written notice and an opportunity to cure, terminate the Contract in whole or in part under the following conditions:

- (a) If Contractor should, voluntarily or involuntarily, seek protection under the United States Bankruptcy Code and Contractor as debtor-in-possession or the Trustee for the

(b) If Contractor should make a general assignment for the benefit of Contractor's creditors;

(c) If a receiver should be appointed on account of Contractor's insolvency;

(d) If Contractor should repeatedly refuse or fail to supply an adequate number of skilled workers or proper materials to carry on the Work as required by the Contract Documents, or otherwise fail to perform the Work in a timely manner;

(e) If Contractor should repeatedly fail to make prompt payment to Subcontractors or for material or labor, or should disregard laws, ordinances or the instructions of the Owner; or

(f) If Contractor is otherwise in breach of any part of the Contract.

(g) If Contractor is in violation of Applicable Laws, either in the conduct of its business or in its performance of the Work.

J.4.2 At any time that any of the above occurs, Owner may exercise all rights and remedies available to Owner at law or in equity, and, in addition, Owner may take possession of the premises and of all materials and appliances and finish the Work by whatever method it may deem expedient. In such case, the Contractor shall not be entitled to receive further payment until the Work is completed. If the Owner's cost of finishing the Work exceeds the unpaid balance of the Contract Price, Contractor shall pay the difference to the Owner.

J.5 TERMINATION FOR CONVENIENCE

J.5.1 Owner may terminate the Contract in whole or in part whenever Owner determines that termination of the Contract is in the best interest of Owner or the public.

J.5.2 The Owner shall provide the Contractor with seven (7) Days prior written notice of a termination for Owner's or for public convenience. After such notice, the Contractor shall provide the Owner with immediate and peaceful possession of the premises and materials located on and off the premises for which the Contractor received progress payment under Section E. Compensation for Work terminated by the Owner under this provision will be according to Section E. In no circumstance shall Contractor be entitled to lost profits for Work not performed due to termination.

J.6 ACTION UPON TERMINATION

J.6.1 Upon receiving a notice of termination, and except as directed otherwise by the Owner, Contractor shall immediately cease placing further subcontracts or orders for materials, services, or facilities. In addition, Contractor shall terminate all subcontracts or orders to the extent they relate to the Work terminated and, with the prior written approval of the Owner, settle all outstanding liabilities and termination settlement proposals arising from the termination of subcontracts and orders.

J.6.2 As directed by the Owner, Contractor shall, upon termination, transfer title and deliver to the Owner all Record Documents, information, and other property that, if the Contract had been completed, would have been required to be furnished to the Owner.

J.6.3 Upon Owner's notice of termination pursuant to either Section J.4 or J.5, if Owner shall so elect, Contractor shall assign the

Owner such subcontracts and orders as Owner shall specify. In the event Owner elects to take assignment of any such subcontract or order, Contractor shall take such action and shall execute such documents as Owner shall reasonably require for the effectiveness of such assignment and Contractor shall ensure that no contractual arrangement between it and its subcontractors or suppliers of any tier or sub-tier shall prevent such assignment.

SECTION K CONTRACT CLOSE OUT

K.1 RECORD DOCUMENTS

As a condition of final payment (refer also to section E.6), Contractor shall comply with the following: Contractor shall provide Record Documents for the entire project to Owner. Record Documents shall depict the project as constructed and shall reflect each and every change, modification, and deletion made during the construction. Record Documents are part of the Work and shall be provided prior to the Owner's issuance of final payment. Record Documents include all modifications to the Contract Documents unless otherwise directed, and accurate MWESB Reports.

K.2 OPERATION AND MAINTENANCE MANUALS

As part of the Work, Contractor shall submit two completed operation and maintenance manuals ("O & M Manuals") for review by the Owner prior to submission of any pay request for more than 75% of the Work. Owner's receipt of the O & M Manuals shall be a condition precedent to any payment thereafter due. The O & M Manuals shall contain a complete set of all Submittals, all product data as required by the specifications, training information, telephone list and contact information for all consultants, manufacturers, installer and suppliers, manufacturer's printed data, record and shop drawings, schematic diagrams of systems, appropriate equipment indices, warranties and bonds. The Owner shall review and return one O & M Manual for any modifications or adjustments required. Prior to submission of its final pay request, Contractor shall deliver two (2) complete and approved sets of O & M Manuals in paper form and one (1) complete and approved set in electronic form to the Owner and Owner's receipt of the O & M Manuals shall be a condition precedent to Owner's obligation to make final payment.

K.3 COMPLETION NOTICES

K.3.1 Contractor shall provide Owner written notice of both Substantial and Final Completion. The certificate of Substantial Completion shall state the date of Substantial Completion, the responsibilities of the Owner and Contractor for security, maintenance, heat, utilities, damage to the Work and insurance, and the time within which the Contractor shall finish all items on the Punch List accompanying the Certificate. Both completion notices must be signed by the Contractor and the Owner to be valid. The Owner shall provide the final signature on the notices. The notices shall take effect on the date they are signed by the Owner.

K.3.2 Substantial Completion of a facility with operating systems (e.g., mechanical, electrical, HVAC) shall be that degree of completion that has provided a minimum of thirty (30) continuous Days of successful, trouble-free operation, which period shall begin after all performance and acceptance testing has been successfully demonstrated to the Owner. All equipment contained in the Work, plus all other components necessary to enable the Owner to operate the facility in the manner that was intended, shall be complete on the Substantial Completion date. The Contractor may request that a Punch List be prepared by the Owner with submission of the request for the Substantial Completion notice.

K.4 TRAINING

As part of the Work, and prior to submission of the final application for payment, the Contractor shall schedule with the Owner training sessions for all equipment and systems as required by the Contract Documents. Contractor shall schedule training sessions at least two weeks in advance of the date of training to allow Owner to provide its personnel with adequate notice. The O & M Manual shall be used as a basis for training. In addition to any off-site training required by the Contract Documents, training shall include a formal session conducted at the Work site after the equipment and/or system is completely installed and operational in its normal operating environment.

K.5 EXTRA MATERIALS

As part of the Work, Contractor shall provide spare parts, extra maintenance materials, and other materials or products in the quantities specified in the Contract Documents prior to final payment. Delivery point for extra materials shall be designated by the Owner.

K.6 ENVIRONMENTAL CLEAN-UP

As part of the Final Completion notice, or as a separate written notice submitted with or before the notice of Final Completion, the Contractor shall notify the Owner that all environmental and pollution clean-up, remediation and closure have been completed in accordance with all Applicable Laws and pursuant to the authority of all agencies having jurisdiction, and Contractor shall provide Owner with any and all documentation related to the same, including but not limited to directives, orders, letters, certificates and permits related to or arising from such environmental pollution. The notice shall reaffirm the indemnification given under Section F.5.1 above. Contractor's completion of its obligations under this Section K.6 and Owner's receipt of documents evidencing such completion shall be a condition precedent to Owner's obligation to make final payment.

K.7 CERTIFICATE OF OCCUPANCY

Owner's receipt of an unconditioned certificate of occupancy from the appropriate state and/or local building officials shall be a condition precedent to Owner's obligation to make final payment, except to the extent failure to obtain an unconditional certificate of occupancy is due to the sole fault or neglect of Owner.

K.8 OTHER CONTRACTOR RESPONSIBILITIES

The Contractor shall be responsible for returning to the Owner all property of Owner issued to Contractor during construction such as keys, security passes, site admittance badges, and all other pertinent items. Upon notice from Owner, Contractor shall be responsible for notifying the appropriate utility companies to transfer utility charges from the Contractor to the Owner. The utility transfer date shall not be before Substantial Completion and may not be until Final Completion, if the Owner does not take beneficial use of the facility and the Contractor's forces continue with the Work.

K.9 SURVIVAL

All warranty and indemnification provisions of this Contract, and all of Contractor's other obligations under this Contract that are not fully performed by the time of Final Completion or termination, shall survive Final Completion or any termination of the Contract.

As indicated in the General Conditions of your contract(s) Section E.2.9, OSU requires that we gather MWESB (Minority, Women's Emerging Small Business) Contractor/Subcontractor information. This is an Oregon State University requirement and the information will be gathered annually and at time of final payment.

- **You must do this step first or the report will not let you add any information:** In Row 1 Column B there is a drop down menu. You must select yearend (if the job has not been completed) or final (if the job is completed and you have submitted for retention). Once you choose yearend or final in the drop down menu there will be areas highlighted in light green and red. Those are the areas that you are required to fill out. If you did not use or planning to use any MWESB then the left side of the report (Light Green area) still needs to be filled out and the red area needs to remain blank.
- If your agency is an MWESB or if you are using/used an MWESB subcontractor then you need to fill out the information in the report that is highlighted in light green and red (see instructions in the next bullet). If you are not an MWESB or used a Subcontractor that is an MWESB then you need to fill out the left side of the form (Light Green areas) and leave the red area blank.
- In row 2 Column B there is another drop down menu, click the drop down menu and choose Fiscal Year 2015.
- In Row 4 Column B there is another drop down menu, click there and choose OSU.

Exhibit 4-Technical Specifications

Includes:

Permits	Section 1
Seasonal Restrictions	Section 2
Access	Section 3
Mobilization	Section 4
Maintenance During Use	Section 5
Damage to Forest Property and Timber	Section 6
Protection of Watershed	Section 7
Fire Prevention	Section 8
Protection of Culturally Sensitive Areas	Section 9
Water Supply and Dewatering	Section 10
Equipment Rental	Section 11
Roadside Clearing	Section 12
Clearing and Grubbing	Section 13
Disposal	Section 14
Compaction	Section 15
Earthwork	Section 16
Surfacing	Section 17
Road Reconditioning	Section 18
Culvert Replacement	Section 19
Culvert Maintenance	Section 20

1) **PERMITS**

- A) Owner has prepared or will prepare the required Forest Practices Act (FPA) "Notice of Operations".
- B) Prior to commencing any operations, Contractor shall read and become familiar with the Forest Practice Notice and any Written Plans required for services to be performed under this Contract.
- C) Any changes to the plan must have Owner approval. Contractor shall comply with all provisions of the Written Plan.

2) **SEASONAL RESTRICTIONS**

- A) "Live" stream work shall be limited to the State "In-Water Work" period, unless otherwise approved in writing by Oregon Department of Forestry and the Owner.
<https://www.dfw.state.or.us/lands/inwater/2024%20Oregon%20In-Water%20Work%20Guidelines.pdf>
- B) From September 15 through June 15 the Contractor will operate all vehicles over 10,000 GVW at reduced tire pressures. The steering axles of these Vehicles shall be at 91 psi and the drive axles shall be at 71 psi.

3) **ACCESS**

- A) Except as otherwise provided for in this contract, Contractor shall have the right of access over, in, and through any Forest Tract listed in this contract, for the purpose of performing the operations. Contractor in so using, improving, or constructing roads, shall at no time have an interest in the land or timber other than the right of access.
- B) Contractor shall be responsible for obtaining all road use permits, paying any road use fees, and performing any maintenance associated with haul tributary to the Listed Tracts.
- C) Contractor shall comply with all applicable terms and conditions of any access documents set forth in the provisions of this contract, which may include requirements to furnish evidence of insurance coverage, performance bond, entering into a third-party agreement, maintenance, or other actions.

4) **MOBILIZATION**

This work consists of moving personnel, equipment, material, and incidentals to the project and performing work necessary before beginning work at the project site. This work also includes obtaining permits, insurance, and bonds.

- A) When the contract establishes separate work periods within the contract time any additional mobilization included as a Bid Item will be retained until the actual work period.
- B) The contract amount for mobilization shall include full compensation for furnishing all labor, materials, tools, equipment and incidentals involved in mobilization.

5) MAINTENANCE DURING USE

Contractor's responsibility for normal road maintenance commences with Contractor's first use of a road for any activity under the contract. Contractor's responsibility shall continue through any active periods until final acceptance of the maintenance is made by Owner. Normal road maintenance applies to all existing roads used for any activity under this contract. A road which is constructed or reconstructed by Contractor shall assume the status of an existing road upon acceptance in writing by Owner. Normal maintenance shall be inclusive of work needed to protect the road from seasonal weather damage, restore damage caused by road use, and safeguard soil, water, and drainage structures, as follows:

- A) While performing normal road maintenance work, Contractor shall not contaminate gravel or bituminous road surfaces by covering or mixing earth or debris from ditches, slides, or other sources. Contractor shall maintain the existing cross section of dirt or graveled roads by blading and shaping the surface and shoulders. Banks shall not be undercut. Contractor shall not waste any of the surface material from the roads by blading it into ditches or off shoulders. Established berms shall be maintained. Additional berms shall be placed where needed to protect fills. Owner may require cross ditching on certain roads. Contractor shall patch and place additional rock on gravel road surfaces as necessary to repair damage and restore the road.
- B) While performing the operations, Contractor shall minimize damage to ditches, cut banks, fill slopes, and road surfaces. Where damage does occur, Contractor shall restore the road to its original condition, as directed by Owner. No track-mounted machinery shall cross any bridge or pavement without first providing a protective barrier between the tracks and surface. The barrier shall be adequate to protect the surface.
- C) Prior to any inactive periods, drainage systems shall be re-established so that exposed soil will not erode into waters of the State and drainage water will not saturate fills.
- D) During active periods, Contractor is responsible for maintenance needs that are caused by public use of the road and that can be accomplished under the terms of normal maintenance. Upon written approval from Owner, Contractor may restrict use of the roads by others. Measures may include signing, gating, or blocking off the road. Approval of measures by Owner does not relieve Contractor from normal maintenance responsibilities during active periods in the event that such measures do not restrict vehicular traffic.
- E) Should Contractor jointly share maintenance responsibilities with other authorized parties to use the roads, then each party shall be responsible for a proportionate part of normal maintenance, based upon the ratio of each party's use to total road use, as determined by Owner. Owner may determine when maintenance is needed and issue instructions to Contractor specifying the work to be done and the date by which it must be completed.
- F) Contractor shall perform all cleanup including the removal of bank slough, minor slides, and fallen timber. This material shall be deposited at the closest location identified by Owner. Contractor shall replace material eroded from fill slopes and clean out drainage ditches and culverts.
- G) Contractor shall be required to place and maintain straw bales for filtering road run-off water before it enters waters of the State upon direction from owner.

6) DAMAGE TO FOREST PROPERTY AND TIMBER

- A) Contractor shall comply with the most current Oregon Forest Practices rules and regulations and otherwise perform the service in accordance with all applicable laws. Contractor shall exercise all reasonable precautions to protect forest ecosystems, roads, and facilities in and adjacent to designated work areas in accordance with instructions and guidelines of the Owner. Contractor shall be held responsible for any violations and fines that result from negligence or misconduct on the Contractor's part.
- B) Contractor shall be exclusively responsible for any damage to reserved timber. If, however, damage to reserved timber occurs and is determined unavoidable by Owner, in Owner's sole and exclusive discretion, then no charge will be made for damage.
- C) If Contractor's activities result in avoidable damage to reserved timber, in Owner's sole and exclusive discretion, Contractor shall fairly compensate Owner at the following rates:
 - 1) Single the stumpage value shall be paid to Owner when:
 - a) "Minor damage" defined as bark removed down to the cambium layer of a tree, such removal affecting at least twenty-four (24) square inches, but less than damage defined as "major damage", to reserved timber occurs during the course of normal operations.
 - b) Trees must be cut in order to facilitate operations, or for safety around work sites, without prior approval of Owner.
 - 2) Double the stumpage value shall be paid when:
 - a) "Major damage" defined as bark removed down to the cambium layer over an area of the bole which has one dimension (height or circumference) greater than the diameter of the tree, or any visible bark removal on the tree roots.
 - b) More than 50 percent of live crown is removed.
 - c) Tree is knocked down or leaning more than 10 degrees from vertical.
 - 3) Triple the stumpage value shall be paid when:
 - a) Reserved timber is intentionally cut or removed;
 - b) Reserved timber is intentionally damaged;
 - c) Repeated major damage occurs to reserved timber;
 - d) Any intentional "notching" or undercutting of reserved timber occurs.
- D) Contractor shall keep all Owner property free from any adverse liens, security interests or encumbrances and shall not commit or permit waste or destruction of Owner property.

7) **PROTECTION OF WATERSHED**

- A) Contractor shall take all necessary precautions to prevent damage to stream banks, any stream course, lake, reservoir, or forested wetland within or adjacent to the project area. Definitions of Type F, Type D, Type N streams and springs, bogs or wetlands contained in the Oregon Forest Practices Act apply to this Contract. Prior to commencing any operations, Contractor shall read and become familiar with the forest practice notice and any written plans required for services to be performed under this Contract.
- B) Stream Clearance: Contractor shall comply with the following instructions for removal of debris that enters streams as a result of Contractor's operations.
- 1) Debris entering all streams shall be removed by the end of operations each day, unless an alternate practice is approved by Owner.
 - 2) Contractor shall notify Owner when debris more than two (2) inches in diameter on the small end and more than six (6) feet in length enters Type F and Type D streams. Contractor shall either leave or remove such debris as directed by Owner.
 - 3) Debris entering Type N streams shall be removed within 14 days of completion of operations.
 - 4) Debris shall be cleared up to the high water mark on all streams. All removed debris shall be placed in a stable location, approved by Owner, above the high water mark.
 - 5) In addition to other protective measures required by Owner, this Contract or professional standards, Contractor shall discontinue all or part of the operations under this Contract upon notice from Owner that operations will cause excessive damage to the watershed, in Owner's sole opinion.
- C) Contractor shall take all precautions necessary to protect the watershed from damage and to prevent pollution to the water supply. Precautions shall include, but not be limited to, the following:
- 1) Laws, Rules and Regulations: Comply with Oregon laws and with the rules and regulations of the Oregon State Board of Health relative to protection of watersheds and sanitation of public water supply.
 - 2) General Sanitary Conditions: Do not create any conditions which may permit breeding of flies or mosquitoes. Machinery, equipment, soil, and fuel storage shall not be located near streams. Waste oil will be removed from the watershed.
 - 3) Contractor shall wash all equipment prior to entering the Research Forests property and prior to exiting the Research Forests property.

- 4) Privies: When work occurs at the same location for more than five (5) consecutive days, place a clean, sanitary, and usable privy at each work site and other main points of operation and require all personnel to use the privies. Privies shall be placed at locations approved by Owner not closer than 100 feet to any stream. The privies shall be constructed as follows, unless other types are approved by Owner prior to being placed in use:
 - a) The housing shall be waterproof and flyproof, and the toilet shall be equipped with a seat and cover.
 - b) A receptacle of not less than 45-gallon capacity shall be provided for all refuse and the privy shall be equipped with a separate urinal draining into the receptacle. Refuse shall be removed from the receptacle and disposed of off the watershed area.
 - c) The receptacle shall be vented through the roof of the privy housing.
 - d) Pit type privies shall not be permitted on the watershed.
- 5) Overnight Camping Prohibited: No person shall remain on the watershed overnight, unless authorized in advance in writing by Owner.

8) FIRE PREVENTION

- A) Contractor shall take adequate measures for the prevention and suppression of fire in conformance with the requirements of the Oregon statutes and the State Forester's regulations. The Owner will check that the Contractor complies with fire rules and regulations at the beginning of each fire season or upon random inspections. The Owner or Oregon Department of Forestry's (ODF) Fire Protection Officer will also conduct spot inspections to ensure that the fire equipment is operational and that Contractor is maintaining a fire safe work site.
- B) Contractor shall suspend operations as needed to conform to the State Forester's regulations, or when, in the judgment of Owner, such suspension is considered necessary for fire safety, and Contractor shall not resume operations until authorized to do so by the Owner. At Owner's request, Contractor shall close active operating areas to other forest users during suspensions to protect persons and equipment and limit liability of Owner and Contractor due to the actions of third parties.
- C) In the event of fire on the Research Forests, or along roads used by the Contractor in any operation, Contractor shall immediately exert every reasonable effort to control, extinguish and prevent the spread of such fire.

9) PROTECTION OF CULTURALLY SENSITIVE AREAS

- A) Location of known historic or prehistoric sites, buildings, objects and properties relating to American history, architecture, archaeology and culture, such as settler or Indian artifacts, protected by Federal and State laws including but not limited to the National Historic Preservation Act (NHPA) of 1966, Section 106, codified in 36 CFR Part 800 (Protection of Historic Properties), ORS 97.740-97.760, 97.990(5) and (6), 358.635-358.653, 358.680-358.690, 358.905-358.961, 390.235-390.240 and OAR Chapter 736, Division 51 shall be identified on the ground by Owner and shown on Contract maps.
- B) Owner may unilaterally modify or cancel all or portions of this Contract to protect an area, object of antiquity, artifact, or similar object which is or may be entitled to protection under these statutes and rules regardless of when the area, object or artifact is discovered or identified. Discovery of such areas by either party shall be promptly reported to the other party and operations will be suspended at that location until the significance or potential significance of the site is determined by Owner.
- C) In the event of Contract modification under this subsection, Contractor shall be reimbursed for any required additional protection measures beyond the scope of this Contract, provided that any work or extra protection required shall be subject to prior approval by Owner. The amount of reimbursement shall be determined by Owner and shall not exceed expended or agreed-upon costs.
- D) Contractor shall protect through avoidance or use of designated travel routes all known and identified historic and prehistoric sites, buildings, objects and properties related to American history, architecture, archaeology, and culture against destruction, obliteration, removal or damage during the Contractor's operations. Contractor and all persons employed by Contractor are prohibited from picking up and removing any cultural resources. Contractor shall bear costs of evaluation and restoration if negligent in its operations in accordance with statutes and rules referenced in this section. Such payment shall not relieve Contractor from civil or criminal remedies otherwise provided by law. Civil sanctions include but are not limited to sole liability for all costs associated with monitoring, recovery, site restoration or other archeological work required by Tribal, Federal, or State authorities.
- E) Prior to any ground disturbing activity, the Contractor shall meet with the Owner and other appropriate parties on site prior to beginning work to ensure that all parties understand the locations of the culturally sensitive sites and the measures that shall be taken to protect them.

10) WATER SUPPLY AND DEWATERING

- A) Suitable and adequate water sources and use restrictions will be designated by Owner at the start of each project. If the Contractor elects to provide water from other than designated sources the Contractor shall be responsible to obtain the right to use the water including any cost for royalties involved. The rate of applications shall be based on the gallonage per mile ordered by the Owner, or as specified in other pay items.
- B) Mobile watering equipment shall have watertight tanks of known capacity. If tank capacity is not known, it shall be measured and certified by the Contractor prior to use.
- C) Positive control of water application is required. Equipment shall provide uniform application of water without puddling or washing.

- D) An air gap or positive anti-siphon device shall be provided between the water source and the vehicle being loaded if the vehicle has been used for other than water haul if the source is a domestic potable water supply, or the water is used for tank mixing with any other materials.
- E) The designated water sources may require some work prior to their use. Such work may include cleaning ponded areas, installing temporary weirs or sandbags, pipe repair, pump installation or other items (appropriate to the Contractor's operations). Flowing non-fish streams may be temporarily sandbagged or a weir placed to pond water. Contractor shall obtain approval on improvements for sandbags or weirs prior to placement. Drafting or diverting water from fish bearing streams may not exceed 10% of the available flow and fish screens must be installed, operated, and maintained according to National Marine Fisheries Service's (NMFS) fish screen criteria. At a minimum, screen openings shall not exceed 3/32 or 0.0938 inches. All dewatering pumping will follow the same guidelines.
- F) Contractor shall submit a written dewatering plan for all operations in live streams that will require channel diversion or dewatering. Owner and State approval of the plan are required prior to commencing any in-stream work.
- G) Unless specified in the Schedule of Items, development of water supply sources shall be incidental to work ordered. If in the Schedule of Items, measurement for development of water supply sites will be the number of sites ordered and accepted.
- H) Unless specified in the Schedule of Items as watering for a specific Section of these specifications, measurement of water haul and application will be incidental. If indicated in the Schedule of Items, measurement shall be M-GALLONS (1,000 gallons) using calibrated tanks, distributors, or accurate water meters furnished by the Contractor. Hauling shall be incidental. In no case will payment be made for more gallons than ordered by the Owner.

11) **EQUIPMENT RENTAL**

This Section establishes the basis for the Owner to order work not otherwise included in the contract.

- A) Equipment under this Section shall be provided with a fully qualified operator. All equipment with an enclosed cab shall have a fully operational CB radio. In addition, the ordered equipment shall be furnished on a fully operational basis, of modern design, in good operating condition with no fuel or oil leaks and shall meet the following **minimum** specifications:
 - 1) **Dozer** - 130 HP, power 6-way blade, rear rippers/scarifiers.
 - 2) **Mini Excavator** - 15,000 lb. operating weight, 50 HP, hydraulic thumb, available 12" and muck/grading bucket.
 - 3) **Small Excavator** - 26,000 lb. operating weight, 90 HP, hydraulic thumb, available muck/grading bucket and hydraulic compactor.
 - 4) **Medium Excavator** - 42,000 lb. operating weight, 130 HP, appx. 1.2 CY bucket, hydraulic thumb, available clamshell bucket and hydraulic compactor.
 - 5) **Large Excavator** - 62,000 lb. operating weight, 200 HP, appx. 1.5 CY bucket.
 - 6) **Front End Loader** - 200 HP, 3 CY bucket, wheeled.

- 7) Backhoe - Digging depth 15 feet, 85 HP, 24-inch backhoe bucket and 1.2 CY loader bucket.
 - 8) Grader - 130 HP, 12 foot moldboard, blade to be equipped with carbide teeth, available rear rippers/scarifiers.
 - 9) Roller - Single drum vibratory and padfoot available, 66-inch drum, 96 HP.
 - 10) Dump Truck- Highway legal, 10 CY dump box, 400 HP.
 - 11) Self-Loading Log Truck - Highway legal, 80,000 GVW, 400 HP, log loading boom and grapple.
 - 12) Log Truck - Highway legal, 80,000 GVW, 400 HP.
 - 13) Water Truck - Highway legal, 250 HP, 4000-gallon capacity, self-filling capability, front and rear discharge nozzles.
 - 14) Log Loader - 130 HP, log-loading grapple and heel boom, 34-foot reach.
 - 15) Brushing tractor - 70 HP, PTO, rotary side mounted mower with 5.5-foot blade and 50 HP.
 - 16) Trailer Mounted Mulcher - 7 tons per hour, 34 HP.
 - 17) Laborer - with required hand tools including: chain saw, hand compactor, flagging equipment (as required). Laborer time spent flagging will be reported as "Flagger".
- B) The Owner, in conjunction with the Contractor, will determine if equipment is to be moved onto and off the site by roading under its own power or by use of Contractor's truck transport. The Work Order will include the method of moving as roading or transport. Subsequent moving of equipment from one portion of the job to another shall be by roading unless otherwise documented in the Work Order. Time for equipment roading will commence with the beginning of the move. Time will be counted for the operator during roading. When equipment is not being actively used on the Project at the time moving is ordered under this Section, time will be counted for the transporting vehicle, but not the equipment being transported.
- C) The Contractor will maintain a daily record showing the actual hours, to the nearest quarter (0.25) hour, that the equipment is in operation and/or laborer is performing work under this item. The Owner and Contractor will rectify differences in recorded hours prior to billing.

12) ROADSIDE CLEARING

- A) Brush, trees, and other vegetation less than four (4) inches in diameter within each area treated shall be cut to a maximum height of six (6) inches above the ground surface or obstruction such as rocks or existing stumps. When work is performed under this section, the Contractor shall remove all limbs which extend into the treated area or over the roadbed to a height of fifteen (15) feet above the traveled way surface elevation.
- B) Signs, markers, and other road related structures, are designated to be retained. Other items to remain will be marked on the ground.
- C) Work under this section will not be ordered to more than twelve (12) feet slope distance along back slope and eight-foot slope distance along the fill slope.

- D) Work may be performed either by hand or mechanically unless specifically designated by Owner. Self-propelled equipment shall not be allowed on cut and fill slopes or in ditches.
- E) Mechanical brush cutters shall not be operated when there are non-Contractor personnel or occupied vehicles within a hazardous distance of immediate operating area.
- F) Trees within the cutting limits which are over four (4) inches in diameter shall be limbed in lieu of cutting unless designated and marked for removal by Owner.
- G) When trees are limbed, limbs shall be cut within four (4) inches of the trunk.
- H) Side mile work will be ordered in uniform width for the length of the listed segments of roads.
- I) Unless otherwise specified by Owner, work shall commence at the edge of the traveled way and proceed away from the road centerline. For roads without a defined traveled way the starting point for cutting will be marked in the field or defined in the Plan of Work.
- J) Materials resulting from the cutting operation in excess of one (1) foot in length or three (3) inches in diameter shall not be allowed to remain on roadway slopes within the treated area, in ditches, or within water courses.
- K) Measurement for cutting side vegetation by the side mile will be the length of roads or segments ordered and accepted. The length will be determined to the nearest one-tenth (1/10) mile on each side of each road.

13) **CLEARING AND GRUBBING**

- A) All debris, trees, stumps, roots, and other protruding vegetative material within the clearing limits shall be cleared, grubbed, removed, and disposed, except the following:
 - 1) Undisturbed stumps outside of roadway or in embankment areas, provided they do not extend more than twelve (12) inches above the original ground (measured from the uphill side) nor closer than two (2) feet to the finished subgrade or one (1) foot to any slope surface and they do not interfere with the placement or compaction of embankments.
 - 2) Grubbing of pits, channel changes, rock sections, and ditches, below the depth of the proposed excavation.
- B) All roots over two and one half (2 ½) inches in diameter within the roadbed area shall be grubbed to a minimum depth of six (6) inches below subgrade. Roots over two and one half (2 ½) inches in diameter protruding from the excavated slope shall be cut flush with the excavated slope surface.
- C) Trees inside right-of-way clearing shall be felled and bucked to lengths specified by Owner. Contractor shall deck the logs according to **14) I)**.
- D) The construction of pioneer roads shall be confined to inside the roadway unless otherwise approved by the Owner.
- E) Treatment of construction slash larger than two and one half (2 ½) inches in diameter and three (3) feet in length shall be accomplished by scattering, and stumps over eighteen (18) inches in diameter at the root collar shall be hauled to designated locations. Construction slash shall be scattered outside the clearing limits without damaging trees.

- F) No construction slash shall be deposited in streams or streambeds. Construction slash that interferes with drainage structures shall be removed immediately.
- G) Grubbed stumps over eighteen (18) inches in diameter at the root collar shall be removed from roadway, hauled, and stacked at locations shown on the drawings (when provided) or as designated.

14) **DISPOSAL**

Dispose of materials using one of the following methods as specified.

- A) **Remove from project** - Recycle or dispose of material legally off the project.
- B) **Burn** - Obtain necessary burning permits. Submit a copy of the burning permits before burning begins. Burn using high intensity burning processes that produce few emissions. Provide a watchperson during the burning operations. When burning is complete, extinguish the fire so no smoldering debris remains.
- C) **Bury** - Bury debris in trenches or pits in approved areas within the right-of-way when approved. Do not bury debris inside roadway prism limits, beneath drainage ditches, or in areas subject to free-flowing water. Place debris in alternating layers of forty-eight (48) inches of debris covered with twenty-four (24) inches of earth material. Distribute stumps, logs, and other large pieces to form a dense mass and minimize air voids. Cover the top layer of buried debris with at least twelve (12) inches of compacted earth. Grade and shape the area. Seed and mulch disposal areas.
- D) **Hazardous Material** - Dispose of material according to Federal, state, and local regulations.
- E) **Windrowing Construction Slash** - Place construction slash outside the roadway in neat, compacted windrows approximately parallel to and along the toe line of embankment slopes. Do not permit the top of the windrows to extend above subgrade. Use construction equipment to matt down all material in a windrow to form a compact and uniform pile. Construct breaks of at least fifteen (15) feet at least every two-hundred (200) feet in a windrow. Do not place windrows against trees.
- F) **Scattering** - Scatter construction slash in designated areas without damaging trees. Limb all logs. Place logs and stumps away from trees, positioned so they will not roll, and are not on top of one another. Limb and scatter other construction slash to reduce slash concentrations. When scattering for erosion control, place construction slash as flat as practicable on the completed slope.
- G) **Chipping** - Use an approved chipping machine to chip slash longer than three (3) feet. Deposit chips on embankment slopes or outside the roadway to a loose depth less than six (6) inches. Minor amounts of chips or ground woody material may be permitted within the roadway if they are thoroughly mixed with soil and do not form a layer.
- H) **Debris Mat** - Use tree limbs, tops, cull logs, split stumps, wood chunks, and other debris to form a mat upon which construction equipment is operated. Place stumps upside down and blend stumps into the mat.
- I) **Decking** - Remove brush from designated log deck areas. Limb and top logs. Merchantable timber not associated with an existing timber sale shall be cut to length meeting the utilization standards set by Owner. Deck logs so that logs are piled parallel to one another; can be removed by standard log loading equipment; will not damage standing trees; will not interfere with drainage, and will not roll. Keep logs in log decks free of brush and soil.
- J) **Removal to designated locations** - Remove construction slash to designated locations.

- K) Piling - Pile construction slash in designated areas. Place and construct piles so that if the piles are burned, the burning will not damage remaining trees. Keep piles free of dirt from stumps.

15) COMPACTION

Compact using one of the following methods as specified.

- A) Placement Method 1 - Use AASHTO T 27 to determine the quantity of material retained on a No. 4 (4.75-millimeter) sieve. Compact as follows:
- 1) More than 80 percent retained on a No. 4 (4.75-millimeter) sieve. Adjust the moisture content to a level suitable for compaction. Fill the interstices around rock with earth or other fine material as practical. Use compression-type rollers at speeds less than six (6) feet per second and vibratory rollers at speeds less than three (3) feet per second. Compact each layer of material full width with one of the following and until there is no visible evidence of further consolidation:
 - a) Four roller passes of a vibratory roller having a minimum dynamic force of 40,000 pounds impact per vibration and a minimum frequency of 1000 vibrations per minute;
 - b) Eight roller passes of a 20-ton compression-type roller; or
 - c) Eight roller passes of a vibratory roller having a minimum dynamic force of 30,000 pounds impact per vibration and a minimum frequency of 1000 vibrations per minute.

Increase the compactive effort for layers deeper than twelve (12) inches as follows:

 - For each additional six (6) inches or fraction thereof, increase the number of roller passes in subsection a), by four passes; or
 - For each additional six (6) inches or fraction thereof, increase the number of roller passes in subsection b) and c), by eight passes.
 - 2) 50 to 80 percent retained on a No. 4 (4.75-millimeter) sieve. Classify the material according to AASHTO M 145. Adjust the moisture content of material classified A- 1 through A-5 to a moisture content suitable for compaction. Adjust the moisture content of material classified A-6 and A-7 to within 2 percent of the optimum moisture content. Use AASHTO T 99 to determine the optimum moisture content of the portion of the material passing a No. 4 (4.75-millimeter) sieve. Multiply this number by the percentage of material passing a No. 4 (4.75-millimeter) sieve, and add 2 percent to determine the optimum moisture content of the material. Use nonvibratory rollers at speeds less than six (6) feet per second and vibratory rollers at speeds less than three (3) feet per second. Compact each layer of material full width according to subsection 1).

- 3) Less than 50 percent retained on a No. 4 (4.75-millimeter) sieve. Classify the material according to AASHTO M 145. For material classified A-1 or A-2-4, determine the maximum density according to AASHTO T 99, Method C.
Adjust the moisture content of material classified A-1 through A-5 to a moisture content suitable for compaction. Adjust the moisture content of material classified A-6 and A-7 to within 2 percent of the optimum moisture content.
Use compression-type or vibratory rollers. Compact each layer of material full width to at least 95 percent of the maximum density. Determine the in-place density and moisture content according to AASHTO T 310 or other approved test procedures. When required, use AASHTO T 224 to correct for coarse particles.
- B) Placement Method 2 -Adjust the moisture content of the material to a moisture content suitable for compaction. Fill the interstices around rock with earth or other fine material as practical. Operate roller compaction equipment over the full width of each layer until there is no visible evidence of further consolidation or, if when a sheepsfoot roller is used, the roller "walks out" of the layer. Make at least three complete passes. Use compression-type rollers at speeds less than six (6) feet per second and vibratory rollers at speeds less than three (3) feet per second. Ensure rollers meet the following requirements:
- 1) Steel wheeled rollers, other than vibratory, capable of exerting a force of not less than 250 pounds per inch of width of the compression roll or rolls.
 - 2) Vibratory steel wheeled rollers equipped with amplitude and frequency controls with a minimum dynamic force of 30,000 pounds impact per vibration, specifically designed to compact the material on which it is used.
 - 3) Pneumatic-tired rollers with smooth tread tires of equal size that will provide a uniform compacting pressure for the full width of the roller and capable of exerting a ground pressure of at least 80 psi.
 - 4) Sheepsfoot, tamping, or grid rollers capable of exerting a force of 250 pounds per inch of width of roller drum.
- C) Placement Method 3 -Adjust the moisture content of the material to a moisture content suitable for compaction. Fill the interstices around rock with earth or other fine material as practical. Operate hauling and spreading equipment uniformly over the full width of each layer until there is no visible evidence of further consolidation. Make at least three complete passes.
- D) Placement Method 4 -Adjust the moisture content of the material to a moisture content suitable for compaction. Fill the interstices around rock with earth or other fine material as practical. Operate hauling and spreading equipment uniformly over the full width of each layer.
- E) Placement Method 5 - Adjust the moisture content of the material to a moisture content suitable for compaction. Compact the complete surface with a bucket of an excavator larger than 39,000 pounds (18 metric ton) Gross Vehicle Weight using a minimum of three blows. Overlap compaction by ½ width of bucket.
- F) Placement Method 6 -Adjust the moisture content of the material to a moisture content suitable for compaction. Compact using an approved mechanical tamper for a minimum of three complete passes.

When compacting with rollers or hauling and spreading equipment is not practical, use approved mechanical tampers for a minimum of three complete passes.

16) EARTHWORK

This work consists of excavating material and constructing embankments. This work also includes furnishing, hauling, stockpiling, placing, disposing, sloping, shaping, compacting, and finishing earthen and rocky material.

- A) Preparation for Roadway Excavation and Embankment Construction - Clear the area of vegetation and obstructions according to **13**). Road pioneering, slash disposal, and grubbing of stumps may proceed concurrently with excavation and embankment. Maintain drainage during pioneering operations.
- B) Conserved Topsoil - When designated, conserve topsoil from roadway excavation and embankment foundation areas. Stockpile conserved topsoil in low windrows immediately beyond the rounding limits of cut and embankment slopes or in other approved locations. Separate conserved topsoil from other excavated material. When designated, place conserved topsoil on completed slopes as directed by Owner.
- C) Roadway Excavation - Excavate as follows:
 - 1) Excavate rock cuts to six (6) inches below subgrade within the roadbed limits. Backfill to subgrade with topping or other suitable material. Compact the material according to **15**).
 - 2) Scarify earth cuts to six (6) inches below subgrade within the roadbed limits. Compact the scarified material according to **15**).
 - 3) Conduct pioneer road excavation and placement operations so material to be treated under **13**) will not be incorporated into the roadway unless specified in the slash treatment method. Maintain drainage during pioneering operations. Remove snow and ice in advance of the work and deposit beyond the roadway limits in a manner that will not waste material or generate sediment. Do not incorporate snow and ice into embankments. Place snow or ice in a manner to prevent resource damage.
 - 4) Drainage feature construction includes all ditches, minor channel changes, drainage dips, catch basins, surface water deflectors, and other minor drainage structures. Compact the material according to **15**). Excavate on a uniform grade between control points.

Do not disturb material and vegetation outside the construction limits. Retrieve material deposited outside the construction limits. Dispose of unsuitable or excess excavation material according to **14**). Replace shortage of suitable material caused by premature disposal of roadway excavation.

Shape to drain and compact the work area to a uniform cross-section at the end of each day's operations.

- D) Subexcavation - Excavate material to the required limits. Dispose of unsuitable material according to **14**). Backfill subexcavated area with suitable material in horizontal layers not exceeding twelve (12) inches in compacted thickness and compact according to **15**). Prevent unsuitable material from mixing with suitable backfill material.
- E) Borrow Excavation - Use suitable roadway excavation in embankment construction. Do not use borrow excavation when it results in excess roadway excavation. Deduct excess borrow excavation from the total borrow excavation quantity.

Obtain borrow source approval from Owner. Develop and restore borrow sources as directed by Owner. Do not excavate beyond the established limits. When applicable, shape the borrow source to permit accurate measurements when excavation is complete.

F) Prepare foundation for embankment construction as follows:

- 1) Embankment over natural ground - Remove topsoil and break up the ground surface to a minimum depth of six (6) inches by plowing or scarifying. Compact the ground surface according to **15**).
- 2) Embankments over an existing asphalt, concrete, or gravel road surface - Scarify gravel roads to a minimum depth of six (6) inches. Scarify or pulverize asphalt and concrete roads to six (6) inches below the pavement. Reduce particles to a maximum size of six (6) inches and produce a uniform material. Compact the surface according to **15**).
- 3) Embankment across ground not capable of supporting equipment - Dump successive loads of embankment material in a uniformly distributed layer to construct the lower portion of the embankment. Limit the layer thickness to the minimum depth necessary to support the equipment.
- 4) Embankment on an existing slope steeper than 1V:3H - Cut horizontal steps in the existing slope to a sufficient width to accommodate placement and compaction operations and equipment. Step the slope as the embankment is placed and compacted in layers. Begin each step at the intersection of the original ground and the vertical cut of the previous step.

G) Embankment Construction - Incorporate only suitable roadway excavation material into the embankment. When the supply of suitable roadway excavation is exhausted, furnish unclassified borrow to complete the embankment. Obtain written approval before beginning construction of embankments over six (6) feet high at subgrade centerline. Construct embankments as follows:

- 1) General -At the end of each day's operations, shape to drain and compact the embankment surface to a uniform cross-section. Eliminate ruts and low spots that could hold water. During all stages of construction, route and distribute hauling and leveling equipment over the width and length of each layer of material. Compact embankment side slopes with a tamping foot roller, by walking with a dozer, or by over-building the fill and then removing excess material to the final slope line. For slopes 1V:1³/₄H or steeper, compact the slopes as embankment construction progresses.
- 2) Embankment within the roadway prism - Place embankment material in horizontal layers not exceeding twelve (12) inches in compacted thickness. Incorporate oversize boulders or rock fragments into the twelve (12)-inch layers by reducing them in size or placing them individually as required below. Compact each layer according to **15**) before placing the next layer.

Material composed predominantly of boulders or rock fragments too large for twelve (12) inch layers may be placed in layers up to twenty-four (24) inches thick. Incorporate oversize boulders or rock fragments into the twenty-four (24) inch layer by reducing them in size or placing individual rock fragments and boulders greater than twenty-four (24) inches in diameter as follows:

- a) Reduce rock to less than forty-eight (48) inches in the largest dimension;
- b) Distribute rock within the embankment to prevent nesting;
- c) Place layers of embankment material around each rock to a depth not greater than that permitted above. Fill voids between rocks; and

- d) Compact each layer according to **15)** before placing the next layer.
- 3) Embankment outside of roadway prism - When placing embankment outside the staked roadway prism, place material in horizontal layers not exceeding twenty- four (24) inches in compacted thickness. Compact each layer according to **15)**.
- H) Drainage Features - Slope, grade, and shape all drainage features. Remove projecting roots, stumps, rock, or similar matter. Maintain all drainage features in an open condition and without sticks, and other debris.
- I) Sloping, Shaping, and Finishing - Complete subgrade, slopes, drainage features, culverts, riprap, and other underground minor structures before placing aggregate courses. Slope, shape, and finish as follows:
- 1) Sloping - Leave earth slopes with uniform roughened surfaces, except as described in Stepped slopes with no noticeable break as viewed from the road. Scale rock slopes. If a slide or slipout occurs on a cut or embankment slope, remove or replace the material and repair or restore damage to the work. Bench or key the slope to stabilize the slide. Reshape the cut or embankment slope to an acceptable condition.
 - 2) Stepped slopes - Where required, construct steps on slopes of 1½V:1H to 1V:2H. Construct the steps approximately eighteen (18) inches high. Blend the steps into natural ground at the end of the cut. If the slope contains non-rippable rock outcrops, blend steps into the rock. Remove loose material found in transitional area. Except for removing large rocks that may fall, scaling stepped slopes is not required.
 - 3) Shaping - Shape the subgrade to a smooth surface and to the cross-section required. Shape slopes to gradually transition into slope adjustments without noticeable breaks. At the ends of cuts and at intersections of cuts and embankments, adjust slopes in the horizontal and vertical planes to blend into each other or into the natural ground.
 - 4) Finishing - Ensure that the subgrade is visibly moist during shaping and dressing; smooth and uniform, and shaped to conform to the typical sections. Remove material larger than six (6) inches from the top six (6) inches of the roadbed. Remove unsuitable material from the roadbed, and replace it with suitable material. Scarify to six (6) inches below the bottom of low sections, holes, cracks, or depressions and bring back to grade with suitable material. Maintain proper ditch drainage.
- J) Disposal of Unsuitable or Excess Material - Dispose of unsuitable or excess material at designated sites or according to **14)**. When there is a pay item for waste, shape and compact the waste material in its final location. Do not mix clearing or other material not subject to payment with the waste material.

17) SURFACING

- A) Roads and subgrades shall be uniformly graded, compacted and approved by Owner prior to rocking. Rocking must be done only when weather conditions are acceptable to Owner, and must be suspended when muddy water could enter streams from runoff. For typical cross sections, see **Typical Drawings**.
- B) Furnish hard, durable particles or fragments of crushed stone or gravel conforming to the size and quality requirements for crushed aggregate material normally used locally in the construction and maintenance of highways by Federal or State agencies. Furnish crushed aggregate uniformly graded from coarse to fine and free of organic matter, lumps or balls of clay, and other deleterious material. River gravel shall not be used.

C) The material from which material is produced or manufactured shall meet the following test requirements:

- 1) Hardness - Test Method AASHTO T 96: 35% Maximum
- 2) Durability - Test Method OSHD Standard Passing No.20 Sieve: 30% Maximum Sediment Height: 75mm Maximum
- 3) Sand Equivalent - Test Method: AASHTO T176 - 35 minimum
- 4) Fractured Faces - Test Method: ASTM D5821 - 75% minimum

Sieve Size	% by Mass Passing Designated Sieve (AASHTO T27 and T11)					
	Grading Designation					
	3/8"-0"	3/4"-0"	1 1/2"-0"	2"-0"	2 1/2"-0"	3"-0"
3 1/2"						100
3"					100	
2 1/2"				100	95-100	60-90
2"			100	95-100		
1 1/2"			95-100		55-75	
1"		100				
3/4"		90-100	55-75	55-75		
1/2"	100					
3/8"	90-100	55-75				
1/4"	25-75	40-60	35-50	30-45	30-45	15-35
No. 10	0-35	*	*	*	*	*

*Of the fraction passing 1/4" sieve, 40%-60% shall pass the NO. 10 sieve.

Jaw-Run	Passing	6" sieve	100%
6"-0" Pit-Run	Passing	10" sieve	100%
	Passing	6" sieve	65%

- D) Upon request by Owner, Contractor shall have samples of the rock tested for gradation, hardness, and durability at a laboratory acceptable to Owner and supply the test results to Owner for approval prior to rocking.
- E) Owner shall be given 24 hours' notice prior to rocking.
- F) Contractor shall supply Owner with weight receipts for all rock placed. Weight receipts must be generated from a State of Oregon certified and sealed scale. The gross weight and truck tare weight for each load must be machine printed on the weight ticket along with the truck number, date, and time. The Contractor shall, along with the weight receipts, supply Owner with a summary sheet of rock quantities hauled and on which road the rock was placed.
- G) Pit-run surfacing rock shall be spread on roads with a crawler tractor and continuously walked- in. Rock spreading shall begin at nearest point from the rock source and progress toward the end of the project, unless otherwise approved in writing by Owner. Compaction shall be accomplished by using one or more of the approved methods in 15).

- H) Crushed rock shall be uniformly mixed and spread in layers on the approved roadbed. Each layer of crushed rock shall be moistened or dried to a uniform moisture content suitable for maximum compaction and compacted in layers not to exceed six (6) inches in depth. When more than one (1) layer is required, each shall be shaped and compacted before the succeeding layer is placed. Any irregularities or depressions that develop during compaction of the top layer shall be corrected by loosening the material at these places and adding or removing material until the surface is smooth and uniform. Compaction shall be accomplished by using one or more of the approved equipment methods in **15**). Roll from the sides to the center, parallel to the centerline of the road. Compact the material along curbs, headers, walls, and places not accessible to a roller with approved tampers or compactors.

18) ROAD RECONDITIONING

This work consists of reconditioning ditches, shoulders, roadbeds, aggregate surfaces, or the entire road.

For all work performed under this section, Contractor shall maintain the dimensions of the existing template in accordance with the corresponding **Typical Drawings** unless otherwise directed by Owner.

- A) Ditch Reconditioning - Remove Slide material, sediment, vegetation, and other debris from existing ditches and culvert inlets/outlets. Reshape ditches and culvert inlets/outlets to achieve positive drainage and uniform ditch width, depth, and grade. Back-slopes shall not be undercut by removal operations.

Dispose of waste at designated sites. Limbs and wood chunks in excess of one (1) foot in length or three (3) inches in diameter shall be removed from ditches and placed outside the roadway.

Suitable material up to four (4) inches in greatest dimension removed from the ditches may be blended into existing native road surface and shoulder. Material from ditch cleaning operations shall not be blended into or bladed across aggregate surfaced roads nor bladed onto or across bituminous surfaced roads. Paved surfaces shall be cleaned of all materials resulting from Contractor's ditch maintenance work. Haul of excess material will be incidental to this item.

Drainage ditch maintenance will be measured to the nearest one-tenth (0.1) mile. Segments of less than one-tenth (0.1) mile will be counted as a full one-tenth (0.1) mile. Lead off ditches are incidental to this item. Lead-off ditches shall be shaped to drain away from the traveled way.

Ditches shall be pulled, and culvert inlets and outlets shall be cleaned and approved by Owner prior to rocking.

Contractor will not disturb any underground utilities marked by signs standard to the industry.

- B) Surface reconditioning - The existing traveled way and shoulders, including turnouts unless otherwise ordered, shall be bladed, shaped, and compacted to produce a surface which is uniform, consistent to grade, free draining, and crowned or cross-sloped as indicated by the character of the existing surface unless otherwise directed by Owner.

Repair soft, unstable, or corrugated areas by scarifying to the full aggregate surface depth, or to the bottom of potholes, ruts, and corrugations on native surface roads. Surfacing materials shall be scarified to no less than two (2) inch depth. Scarification shall not go deep enough to cause contamination of the surfacing. Scarification will be considered incidental to blading. Scarified areas shall be compacted according to **15**) prior to placing repair rock.

The Contractor shall apply water during blading when sufficient moisture is not present. Water supply, hauling, and application will be considered incidental to blading.

The Contractor shall establish a blading pattern which provides a uniform driving surface, retains the surfacing on the roadbed and provides a thorough mixing of the materials within the completed surface width. Upon final blading, no disturbed rock shall protrude more than two (2) inches above the adjacent surface unless otherwise provided in the contract. Material not meeting this dimension shall be removed and placed outside the roadbed so as not to obstruct drainage-ways or structures. This material may be scattered off the roadbed if there is free drainage.

Roadbed width in excess of the dimensions shown on the corresponding **Typical Drawings** shall be shaped only as needed to provide drainage away from the traveled way. Established grasses and other vegetation shall not be removed from the excess width except as incidental to providing drainage or unless otherwise provided in the contract.

Surface blading shall be performed during the contract period as ordered by the Owner. Contractor shall commence surface blading within two (2) contract days after receipt of written order unless otherwise stated in the order.

Roadway back-slope shall not be undercut.

Materials resulting from work under this Section shall not be allowed to remain on or in structures, such as bridges, culverts, cattle guards, or drainage dips.

Measurement for blading will be single-lane mile measured along the centerline of the roadway. Measurement will be measured to the nearest one-tenth (0.1) mile.

19) **CULVERT REPLACEMENT**

This work includes removal of existing culverts, bed preparation, and installation and backfill of new culverts of the size and length specified.

- A) Culverts shall be furnished by the Contractor unless otherwise directed by Owner. Culverts shall meet the following specifications:
- 1) Culverts shall be constructed of corrugated aluminized steel type 2, and shall conform to the material and fabricating requirements of AASHTO M274 (aluminized steel type 2 material) ASTM A 929, AASHTO M36 and ASTM A760 (conduit, pipe) **OR**
 - 2) Polyethylene culverts (18" to 48" in diameter), double walled, and meet the requirements of AASHTO M-294-901, Type S. Corrugation types and shapes other than those meeting minimum State Highway requirements, must be approved in writing by OWNER.
 - 3) On new installations of pipe of like material, joining shall be done with bands of like material and corrugations. Manufacturers' instructions shall be followed for prefabricated pipe assembly. The joints between bands and pipe of unlike material shall be coated with an approved bituminous material.
 - 4) Transporting of pipe shall be done carefully. Dragging or allowing free fall from trucks or into trenches shall not be permitted. Damage to coatings shall be repaired before the pipe is covered.
 - 5) Lengths of individual culvert sections shall be not less than ten (10) feet, unless otherwise provided for in special instructions.

- B) Culverts shall be located according to the alignment and grade as shown on the Plan and Profile, **Typical Drawings**, and/or as staked in the field, or as stipulated in special instructions. Culvert grade shall slope away from ditch grade at least 2 percent unless otherwise specified.
- C) Excavation for culverts shall provide at least eighteen (18) inches of width on either side of the of the pipe to accommodate compaction equipment. Culvert excavation shall comply with all OSHA standards for trench safety. The trench bed shall be subexcavated to accommodate culvert bedding, shaped to uniform grade, and compacted for its entire length and width. If necessary, dewatering and removal and replacement of unsuitable material shall be completed prior to compaction and placement of bedding. The foundation and trench walls for all culverts shall be free from logs, stumps, limbs, stones over three (3) inches, and other objects which could damage or distort the pipe during installation or use. Bedrock shall be excavated as required to provide a uniform foundation for the full length of the culvert. The culvert shall be installed to maintain a uniform flow line from inlet to outlet ditch.
- D) Do not place or backfill pipe that meets any of the following conditions until the excavation and foundation have been approved by Owner:
- 1) Embankment height greater than six (6) feet at subgrade centerline.
 - 2) Installation in a stream.
 - 3) Round pipe with a diameter of forty-eight (48) inches or greater.
 - 4) Any box culvert, pipe arch, or structure other than pipe culverts.
- E) Bed pipes with a six (6) inch uncompacted layer of well-graded 3/4"-0" or finer crushed aggregate in sufficient length and width to provide a wide band of support evenly over the entire length of the pipe. Culverts less than thirty-six (36) inches in diameter shall be installed with the lock seam on the inlet end placed within 45 degrees of the bottom of the trench.
- F) Backfill using the same material supplied for bedding placed in layers not exceeding six (6) inches loose thickness and compacted under the haunches and alongside the pipe. The material shall be readily compactable and free of frozen lumps, chunks of highly plastic clay or other objectionable material. Rocks larger than three (3) inches in greatest dimension shall not be used within one foot (1) of the pipe. Aggregate backfill material shall be used until backfill is a minimum of twelve (12) inches above the top of the culvert, after which suitable on-site material may be used.
- G) Aggregate bedding and backfill material shall be furnished by the Contractor, placed as specified above, and compacted per **15)**. Crushed aggregate shall be incidental to the cost of the culvert.
- H) Minimum cover height shall be twelve (12) inches or manufacturers specified minimum cover, whichever is greater. Add six (6) inches of additional cover for native surface roads. Maximum cover depths shall be per manufacturers specifications.
- I) The ends of each culvert shall be free of logs and debris which would restrict the free flow of water. Culverts in Type F streams must allow free passage of fish as provided in the Oregon Forest Practice Rules. The outlet end of any culvert which would allow water to erode embankment soil into waters of the State shall be provided with a downspout or other approved slope protection device.
- J) Removed culverts become the property of the Contractor. Disposal will not be allowed on the Owners land.

20) CULVERT MAINTENANCE

This work consists of cleaning and reconditioning culverts and other drainage structures

- A) Drainage structures, inlet structures, culverts, catch basins, and outlet channels shall be cleaned when required by the Owner. Catch basins shall be cleaned by reshaping to the dimensions shown in the **Typical Drawings**.
- B) The transition from the ditch line to the catch basin shall be cleaned a distance of ten (10) feet. Outlet channels and lead-off ditches shall be cleaned a distance of six (6) feet. Debris and vegetation shall be removed and placed so as to not enter the channel or ditch or obstruct traffic. Debris and vegetation ordered to be hauled shall be hauled to a designated disposal area in accordance with **14**).
- C) Hydraulic flushing of drainage structures is not allowed unless directed by the Owner.
- D) Cleaning is limited to the first four (4) feet of inlet and outlet determined along the top of structure. Damaged culverts shall be reported to the Owner in writing upon completion of work on each road. Any damage by the Contractor shall be repaired at Contractor's expense.

UNIT PRICES
Section 01 22 00

PART 1 GENERAL

1.01 DESCRIPTION

- A. Provide unit prices for the Work described herein.

1.02 QUALITY ASSURANCE

- A. For each unit price item which is performed, coordinate the work of the various trades involved, and modify surrounding work as required to complete the project, as intended.
- B. In the figure for each unit price, include incidental costs which, as attributable to adjustments in the work of other trades, may be required to achieve the contemplated final conditions.
- C. If there is a question regarding the extent, scope, nature, or intent of the unit price work, contact the Owner for clarification. Failure on the part of the Contractor to clarify any unclear items shall not relieve the Contractor of the responsibility for performing the Work in accordance with the intent and requirements of the Project Manual or Drawings.
- D. The description of unit price items listed hereinafter is qualitative. The quantities listed are estimated quantities and are included for the purpose of award of the Contract. Actual quantities of labor and materials required to execute the unit price items of Work will be determined by project conditions and with concurrence of the Owner's Authorized Representative.

PART 2 PRODUCTS

2.01 GENERAL

- A. The applicable Sections of the Specifications apply to the Work under each unit price item.

PART 3 EXECUTION

3.01 LIST OF UNIT PRICE ITEMS OF WORK

- A. See Schedule of Items, attached.

END OF SECTION

TYPICAL SECTIONS

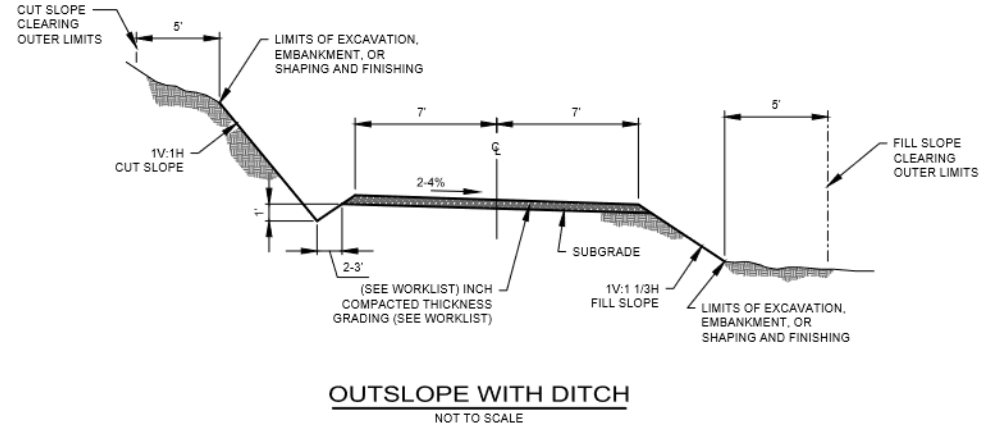
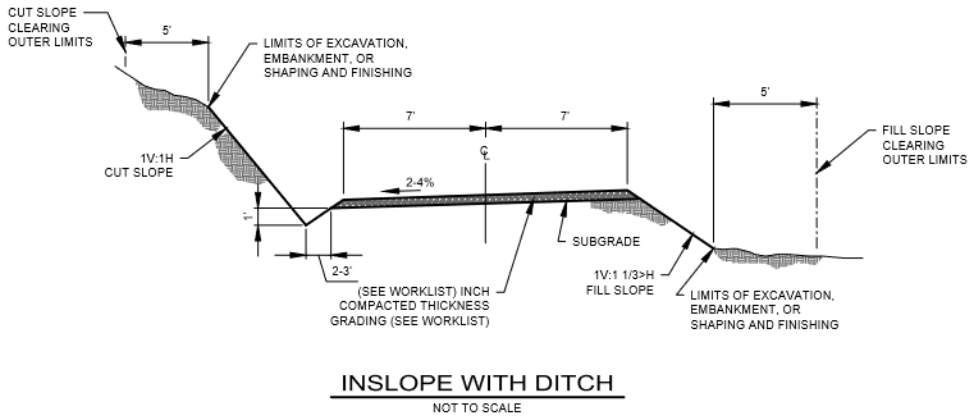
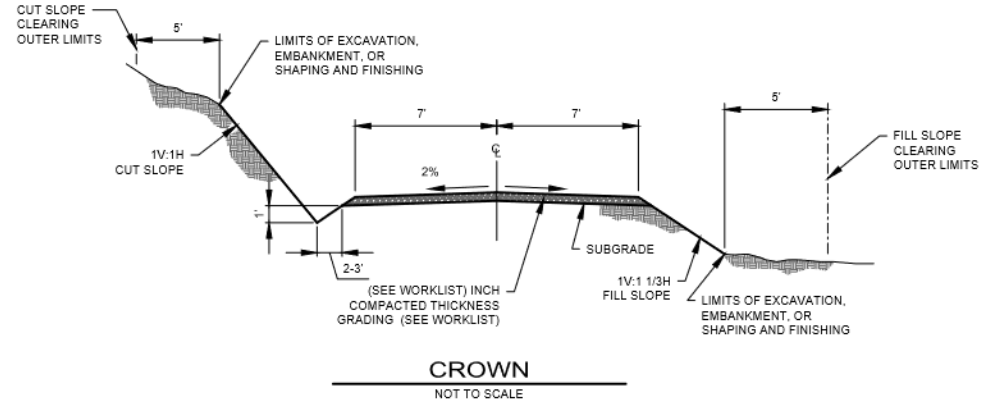
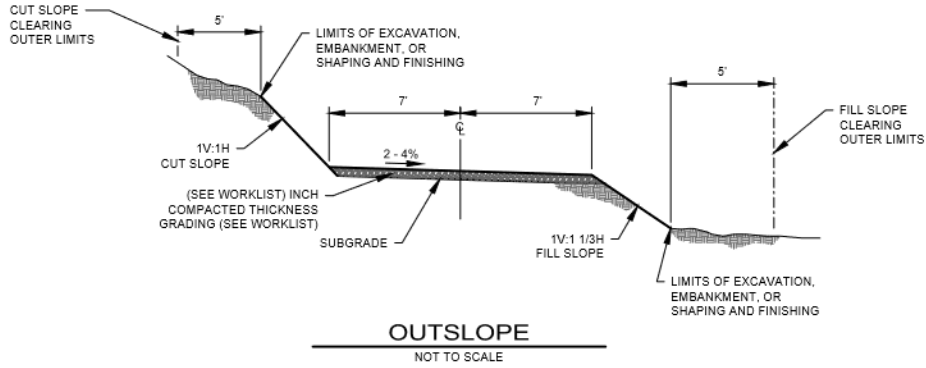

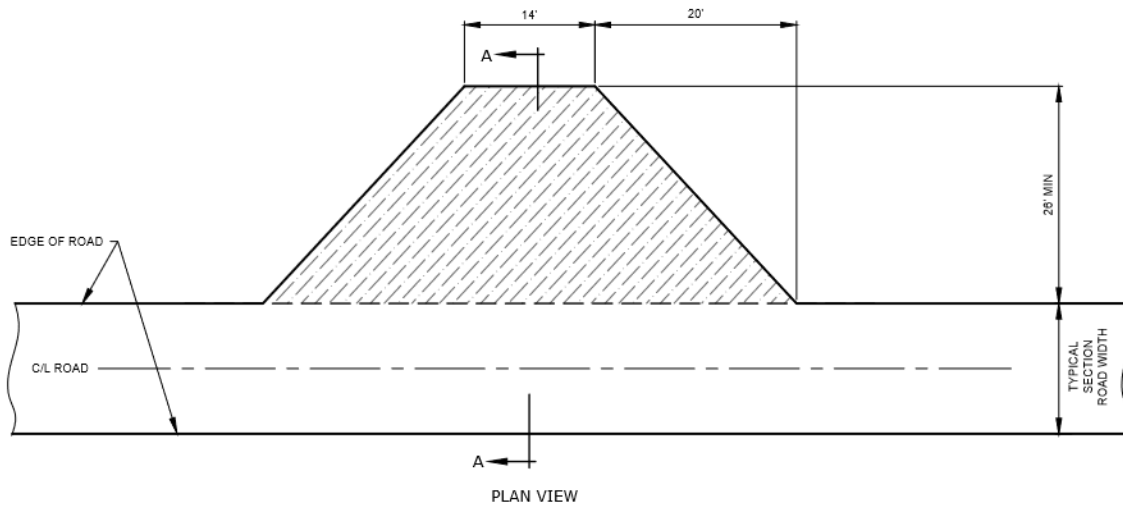
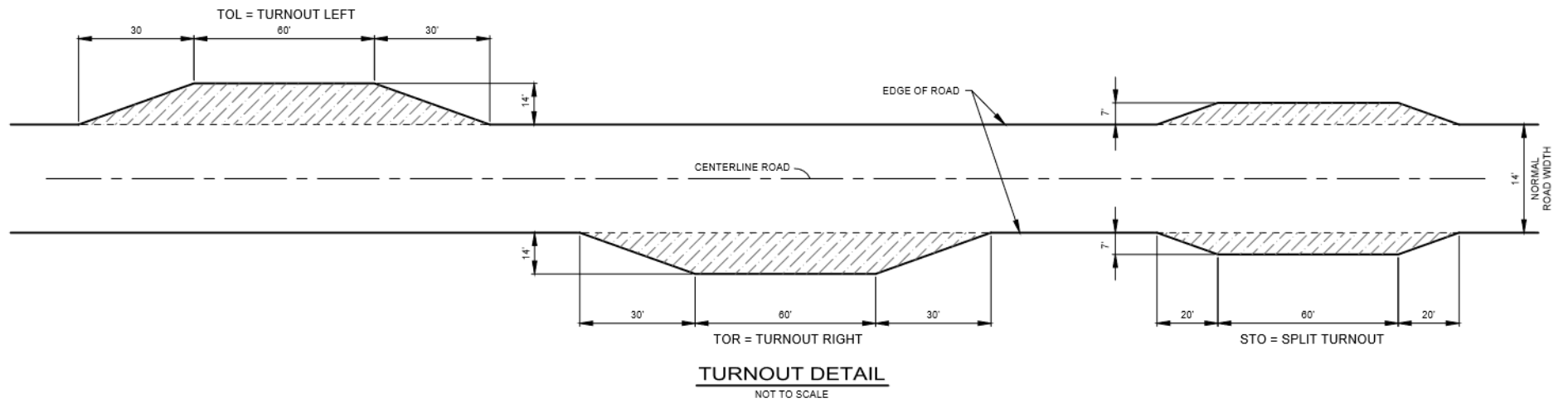

TURNAROUND DETAIL
NOT TO SCALE

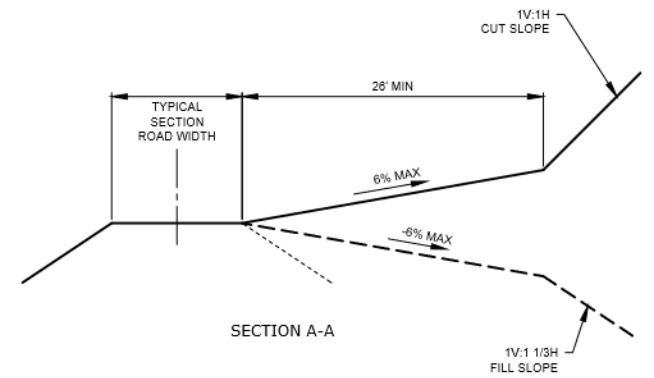

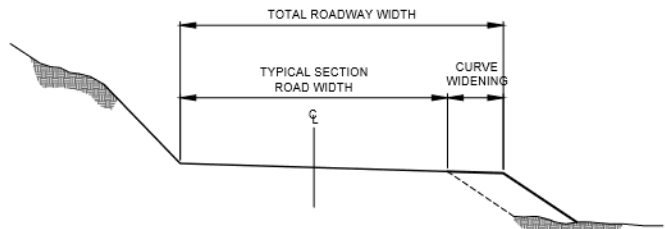

FILL SLOPE CURVE WIDENING
NOT TO SCALE

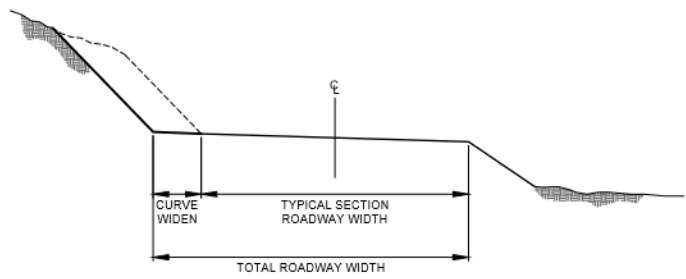

CUT SLOPE CURVE WIDENING
NOT TO SCALE

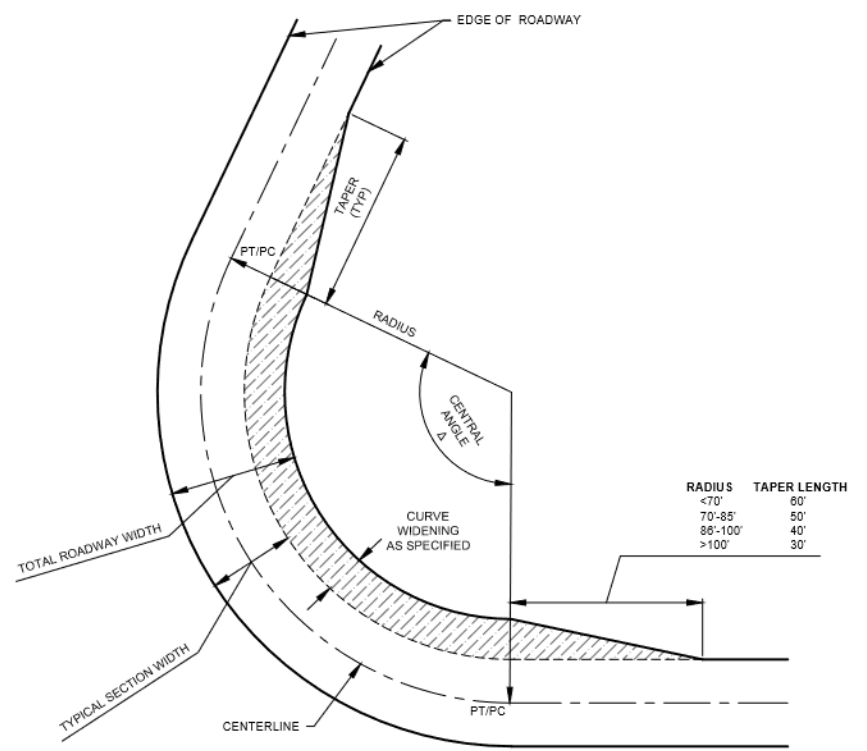

RADIUS	TAPER LENGTH
<70'	80'
70'-85'	50'
86'-100'	40'
>100'	30'

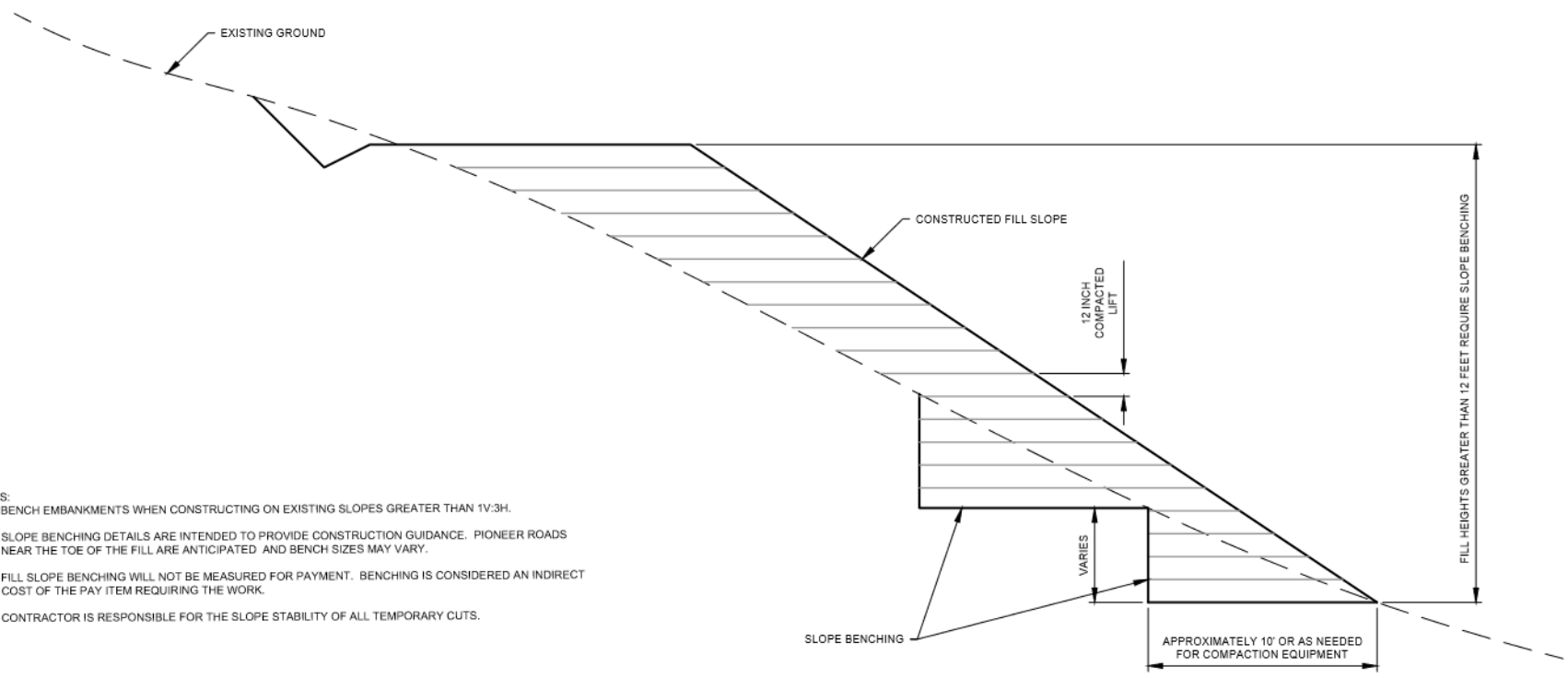

- NOTES:
1. BENCH EMBANKMENTS WHEN CONSTRUCTING ON EXISTING SLOPES GREATER THAN 1V:3H.
 2. SLOPE BENCHING DETAILS ARE INTENDED TO PROVIDE CONSTRUCTION GUIDANCE. PIONEER ROADS NEAR THE TOE OF THE FILL ARE ANTICIPATED AND BENCH SIZES MAY VARY.
 3. FILL SLOPE BENCHING WILL NOT BE MEASURED FOR PAYMENT. BENCHING IS CONSIDERED AN INDIRECT COST OF THE PAY ITEM REQUIRING THE WORK.
 4. CONTRACTOR IS RESPONSIBLE FOR THE SLOPE STABILITY OF ALL TEMPORARY CUTS.

FILL SLOPE BENCHING
NOT TO SCALE

ROAD SUBGRADE REINFORCEMENT - TYPICAL

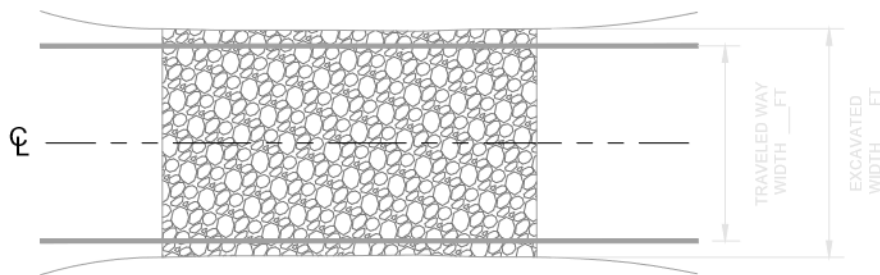

PLAN VIEW

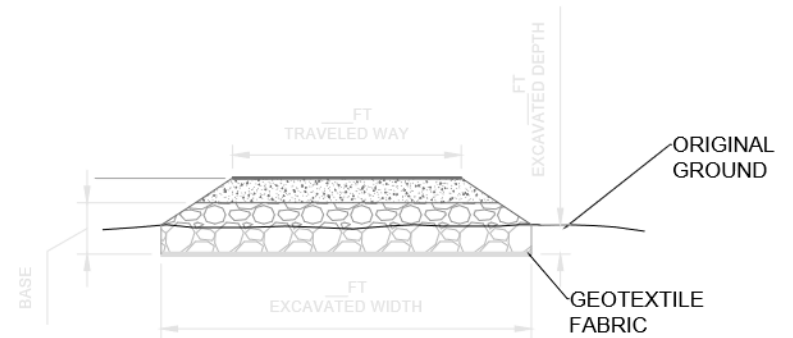

CROSS SECTION VIEW

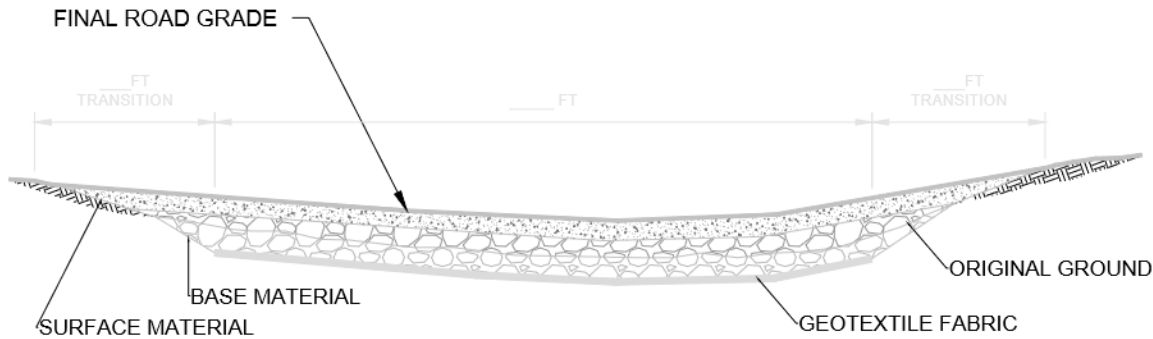

PROFILE VIEW

NOTES:
 DISPOSE OF UNSUITABLE EXCAVATION
 AT LOCATION APPROVED BY OSU.

 SEE WORKLIST FOR DIMENSIONS AND
 MATERIALS

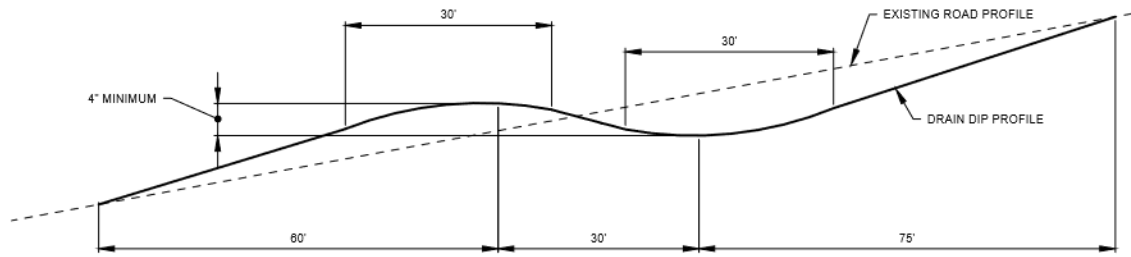

DRAIN DIP - LOG TRUCK
NOT TO SCALE

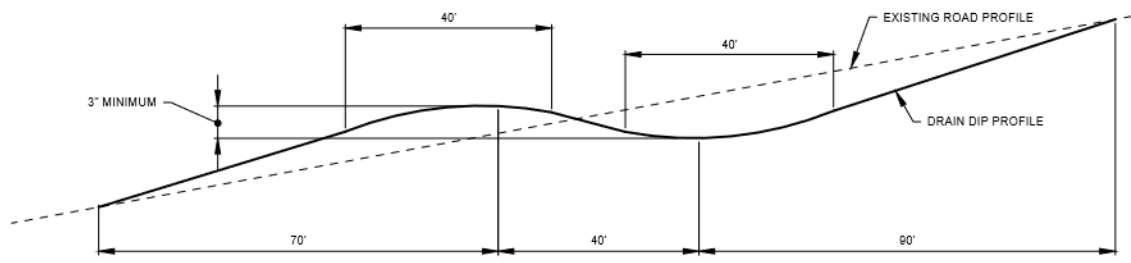

DRAIN DIP - LOWBOY
NOT TO SCALE

- NOTES:
1. CROSS SLOPE OF THE LOW POINT DRAINLINE SHALL BE 5%.
 2. SKEW OF DRAINLINE SHALL BE 0-25 DEGREES.
 3. UNLESS OTHERWISE SPECIFIED IN THE WORKLIST DO NOT INTERCEPT THE ROADWAY DITCH.

CLEARING DETAILS
NOT TO SCALE

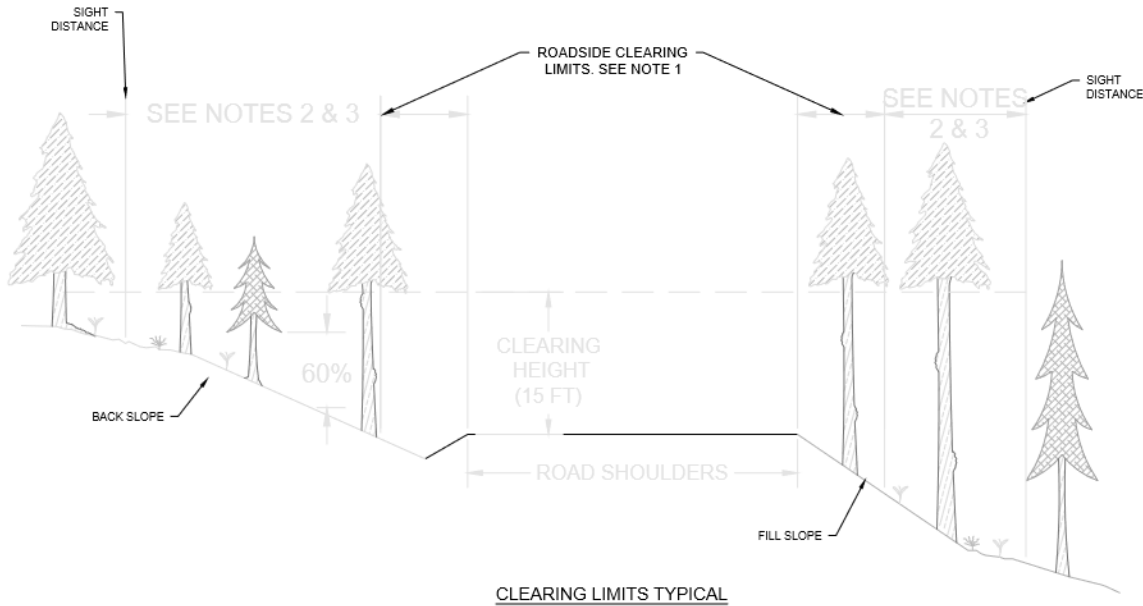

CLEARING LIMITS TYPICAL

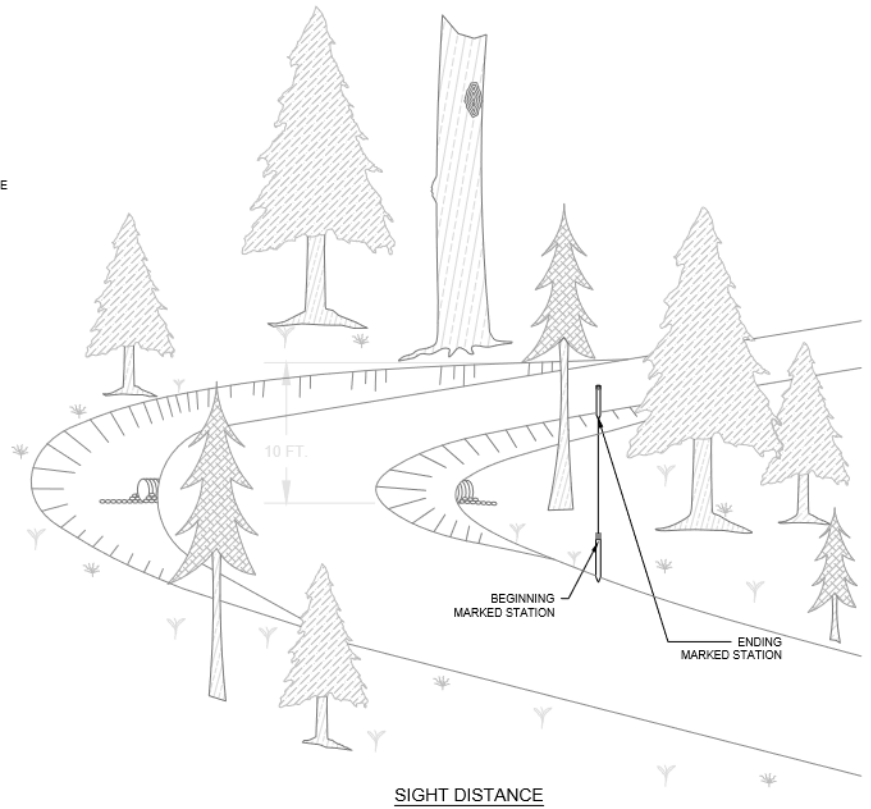

NOTES:

1. ALL CONIFERS, HARDWOODS AND BRUSH WITHIN 5 FEET OF THE SHOULDERS OF THE ROAD OR THE BOTTOM OF THE DITCH SHALL BE REMOVED.
2. THE AREA OF SIGHT DISTANCE CLEARING WILL BE FROM THE ROADSIDE CLEARING LIMIT TO A LINE OF SIGHT BETWEEN THE BEGINNING AND ENDING STATIONS MARKED ON THE GROUND. CONIFERS WITHIN THIS AREA SHALL BE THINNED TO APPROXIMATELY A 2 FOOT TRUNK SPACING, EXCEPT WHERE MARKED WITH PAINT OR FLAGGING FOR REMOVAL TO AN ALTERNATE SPACING. ALL HARDWOODS AND BRUSH WITHIN THESE LIMITS SHALL BE REMOVED.
3. BRANCHES ON REMAINING CONIFERS SHALL BE TRIMMED FROM GROUND LEVEL TO A CLEARING HEIGHT LIMIT 10 FEET ABOVE THE ROADBED OR TO A LIMIT OF 60% OF THE TREE'S HEIGHT, WHICHEVER IS LESS. LIMBS OF VEGETATION SHALL BE CUT SO AS NOT TO PROTRUDE WITHIN THE CLEARING (ROADSIDE AND HEIGHT) LIMITS.

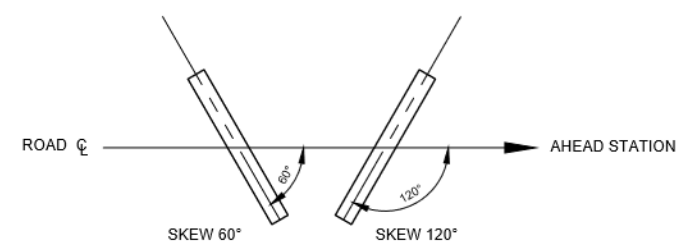
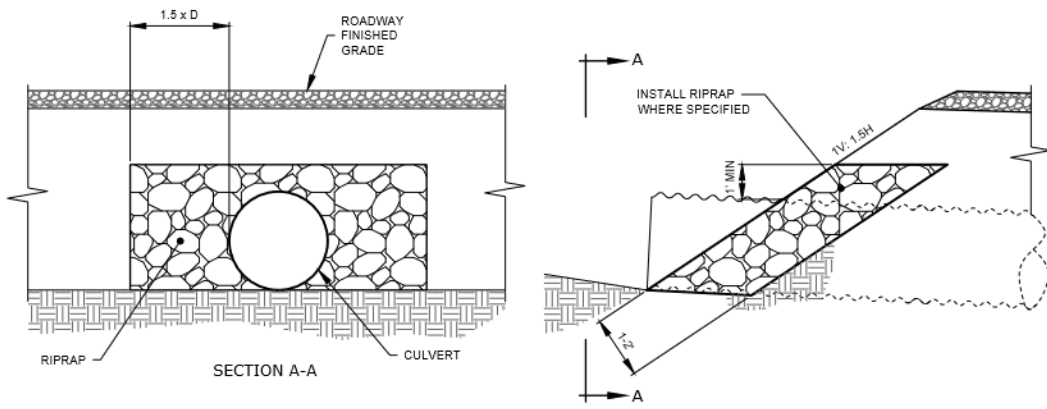
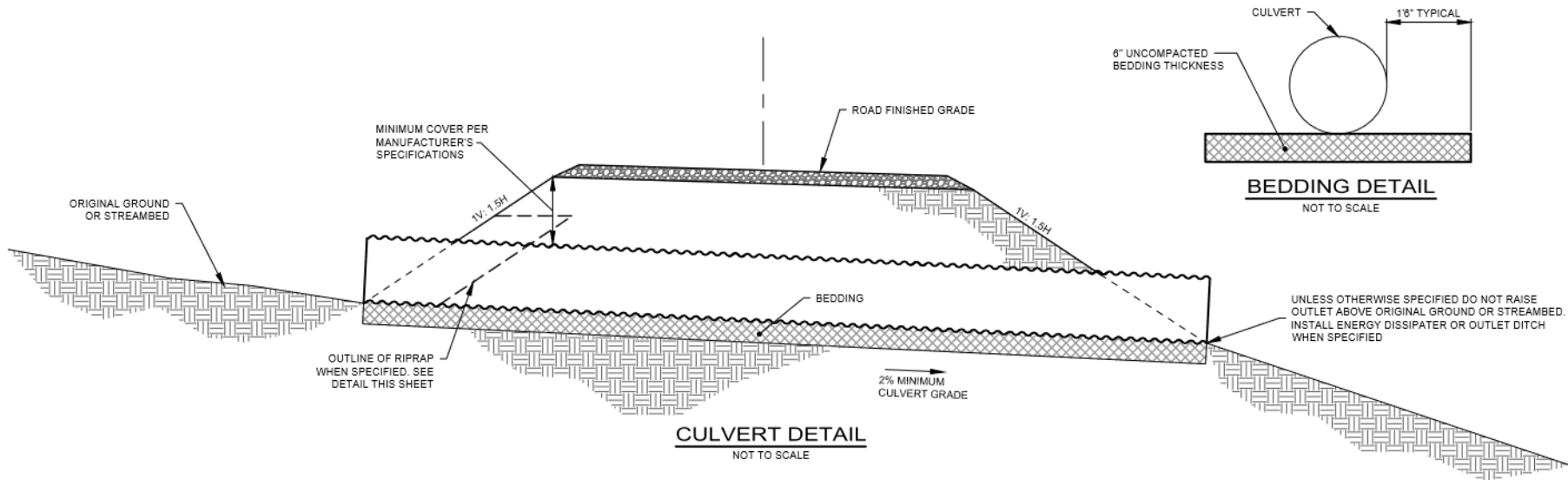

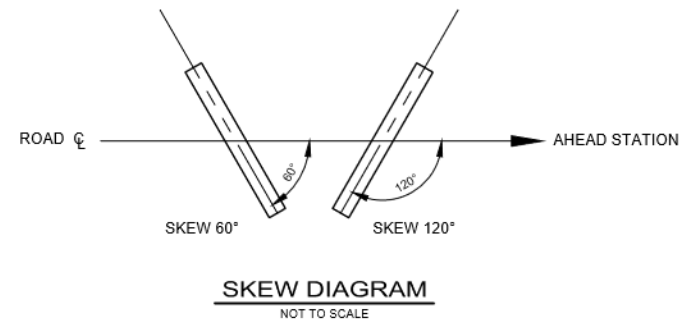
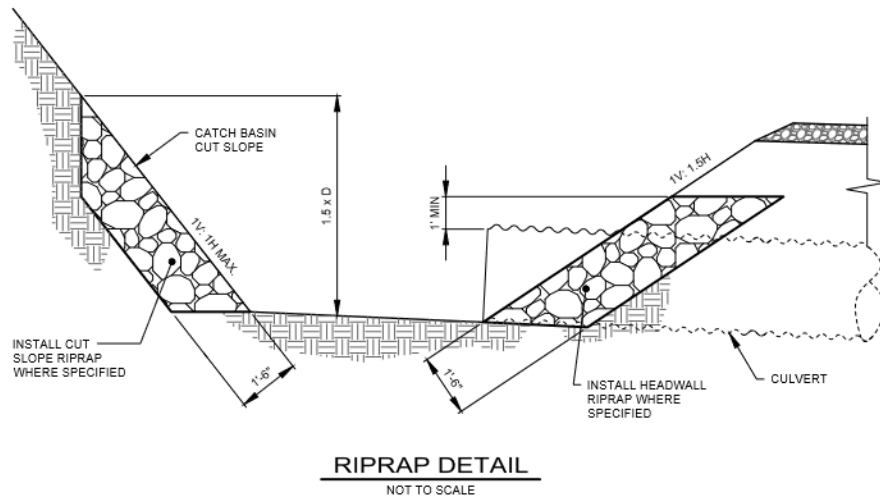
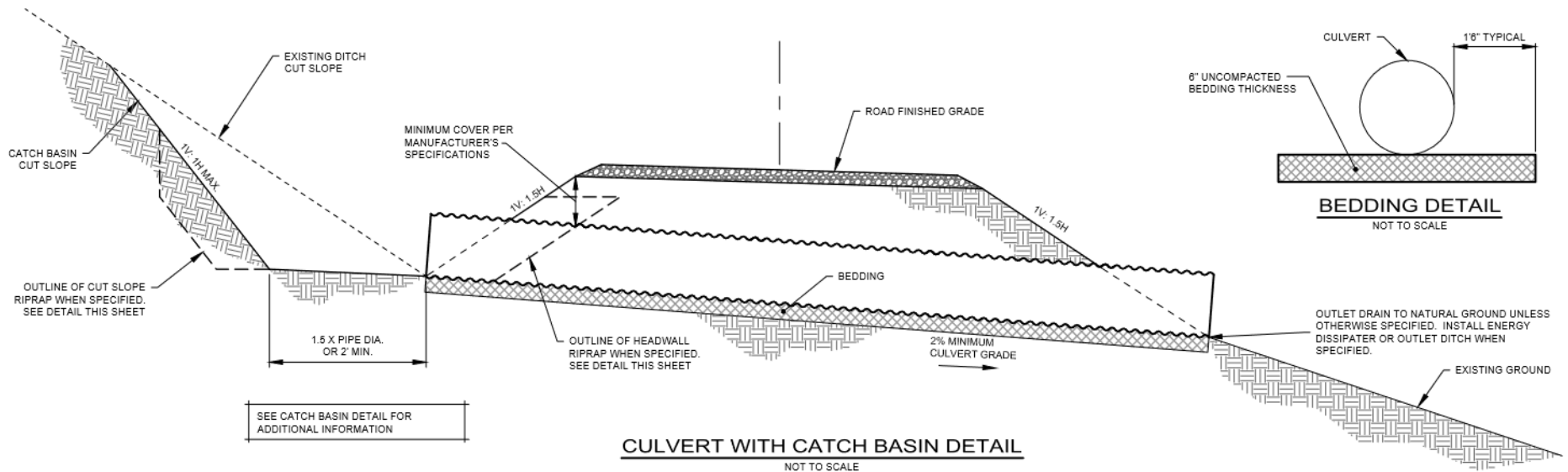

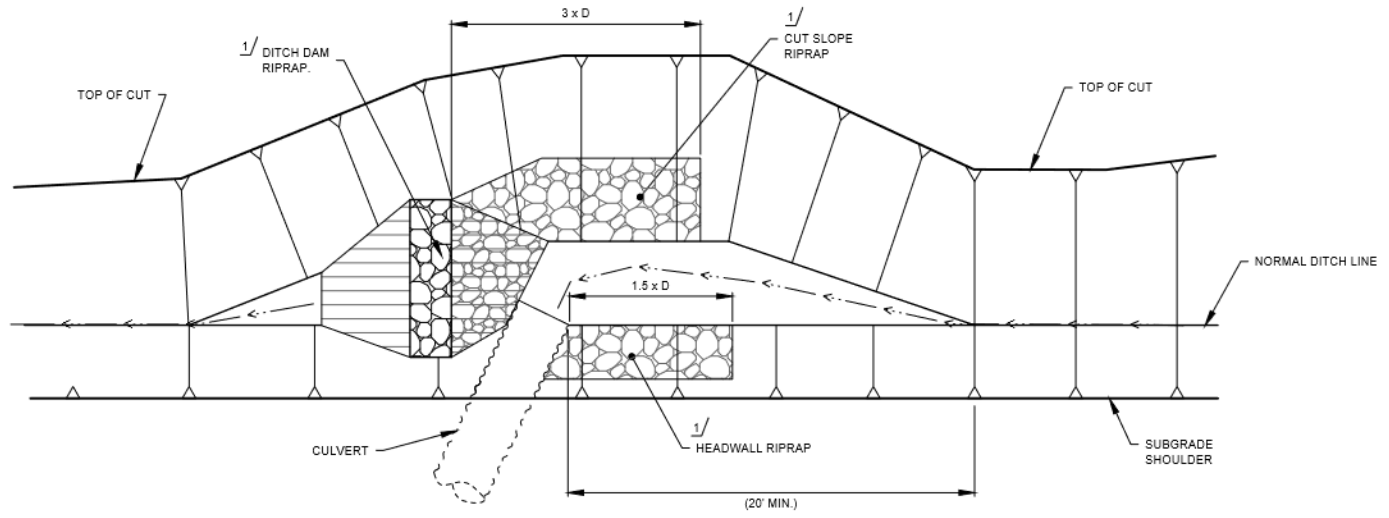

PLAN VIEW

$1/$ INSTALL RIPRAP WHEN SPECIFIED

CATCH BASIN DETAIL
NOT TO SCALE

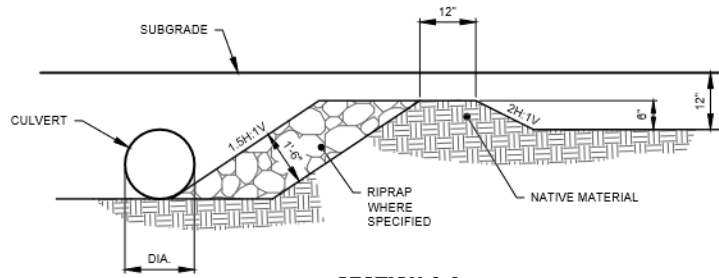

SECTION A-A

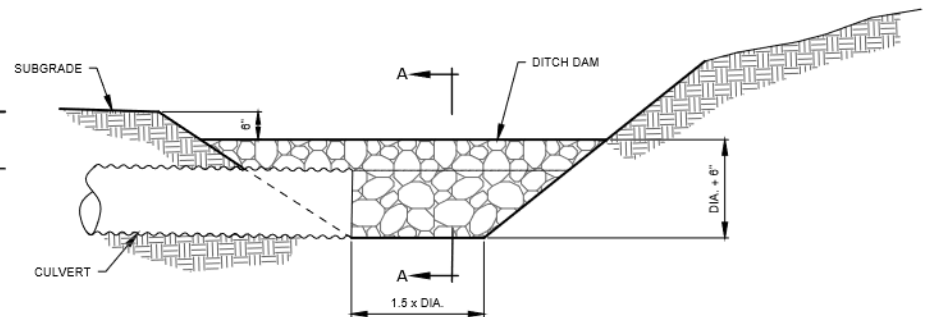

CATCH BASIN ELEVATION

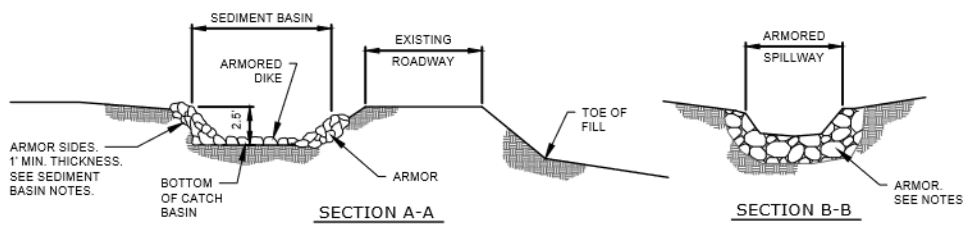
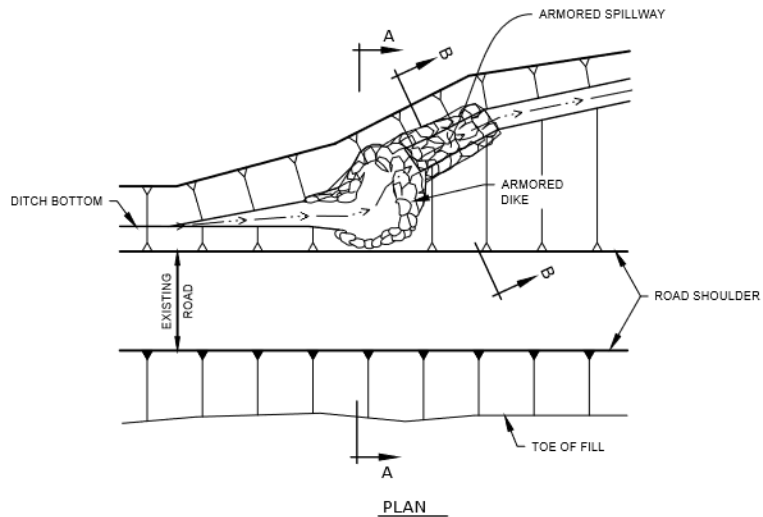

SEDIMENT BASIN

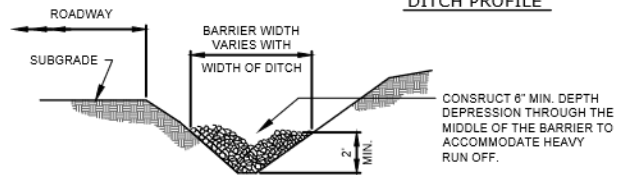
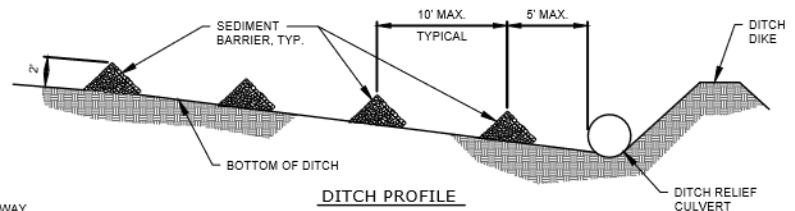
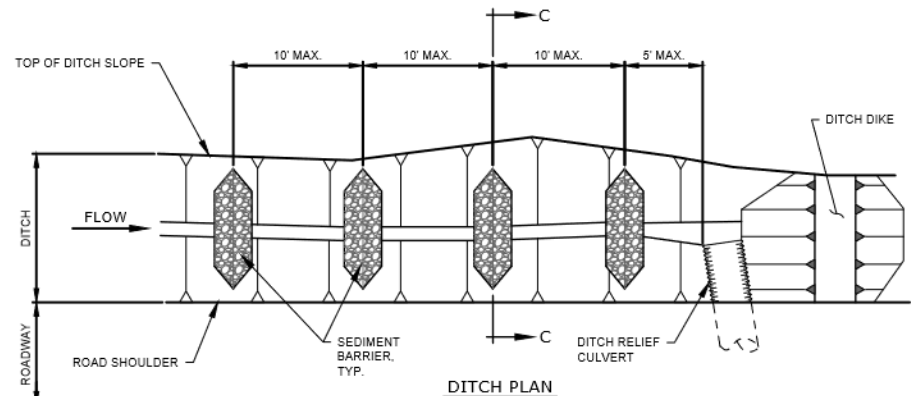

SEDIMENT TRAPS

SEDIMENT TRAP NOTES:

- 1.) CONSTRUCT SEDIMENT BARRIERS USING ROCK THAT RANGES IN SIZE FROM 2" MINIMUM TO 5" MAXIMUM.
- 2.) DO NOT CONSTRUCT BARRIERS HIGHER THAN 6" BELOW THE ADJACENT SUBGRADE ELEVATION.

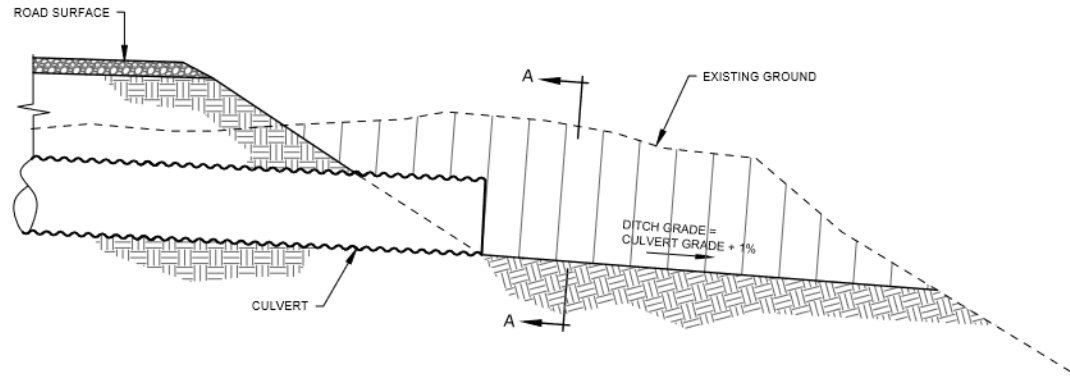

SECTION ALONG CENTERLINE CULVERT/OUTLET DITCH

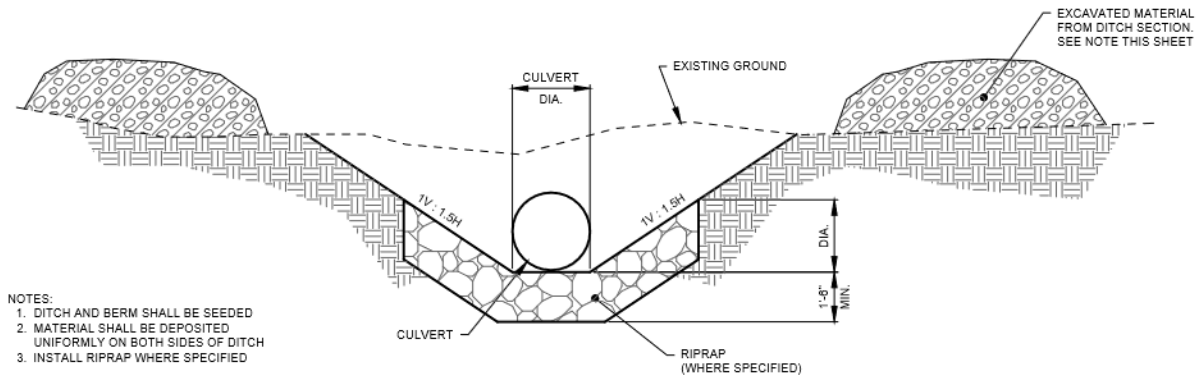

- NOTES:
1. DITCH AND BERM SHALL BE SEEDED
 2. MATERIAL SHALL BE DEPOSITED UNIFORMLY ON BOTH SIDES OF DITCH
 3. INSTALL RIPRAP WHERE SPECIFIED

SECTION A-A

OUTLET DITCH

NOT TO SCALE

OUTLET FLUME

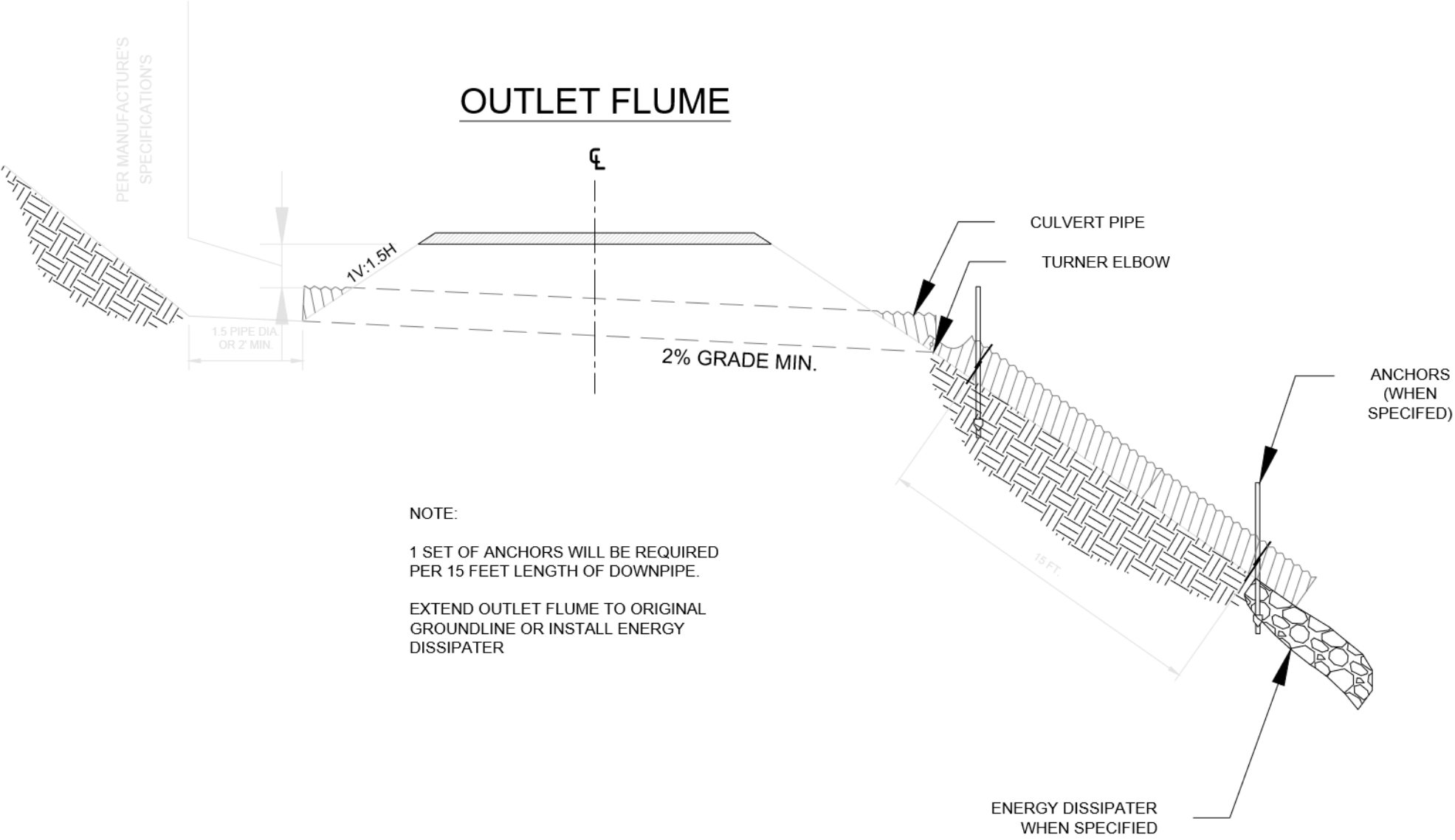

NOTE:
 1 SET OF ANCHORS WILL BE REQUIRED PER 15 FEET LENGTH OF DOWNPIPE.
 EXTEND OUTLET FLUME TO ORIGINAL GROUNDLINE OR INSTALL ENERGY DISSIPATER

ENERGY DISSIPATOR

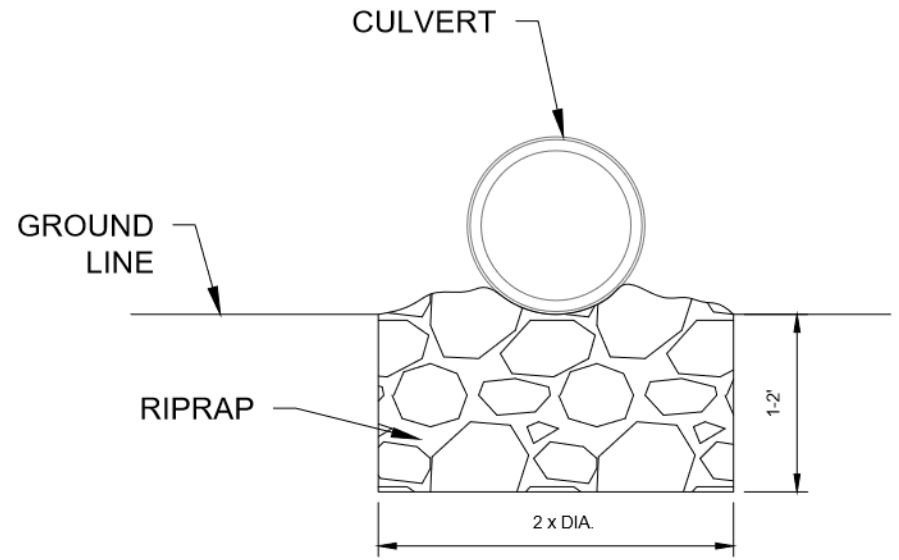
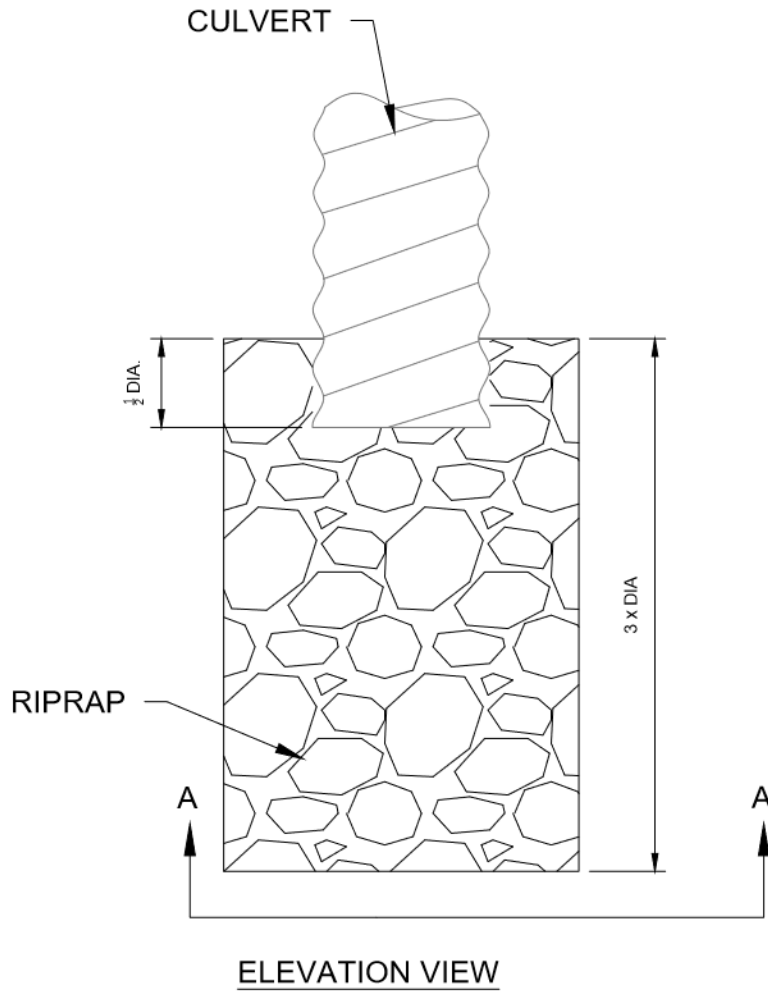

NOTE:
APRON SURFACE SHALL BE LEFT WITH PROTRUDING
RIPRAP FOR VELOCITY BREAK.

ROAD DECOMMISSIONING CULVERT REMOVAL-TYPICAL

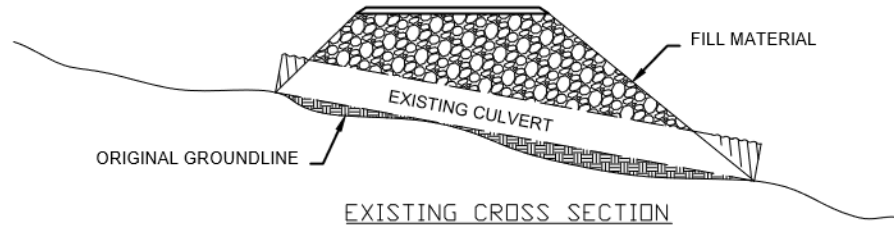

NOTES:

1. EXCAVATE TO ORIGINAL GROUND LINE, REMOVING THE CULVERT AND ALL FILL MATERIAL WITHIN DRAINAGE LIMITS.
2. EXCAVATED CHANNEL MAY REQUIRE ROCK ARMOR, AS DIRECTED BY DSU.
3. IF OLD CLEARING SLASH IS FOUND, SCATTER ON FINISH SLOPE AS DIRECTED BY DSU.

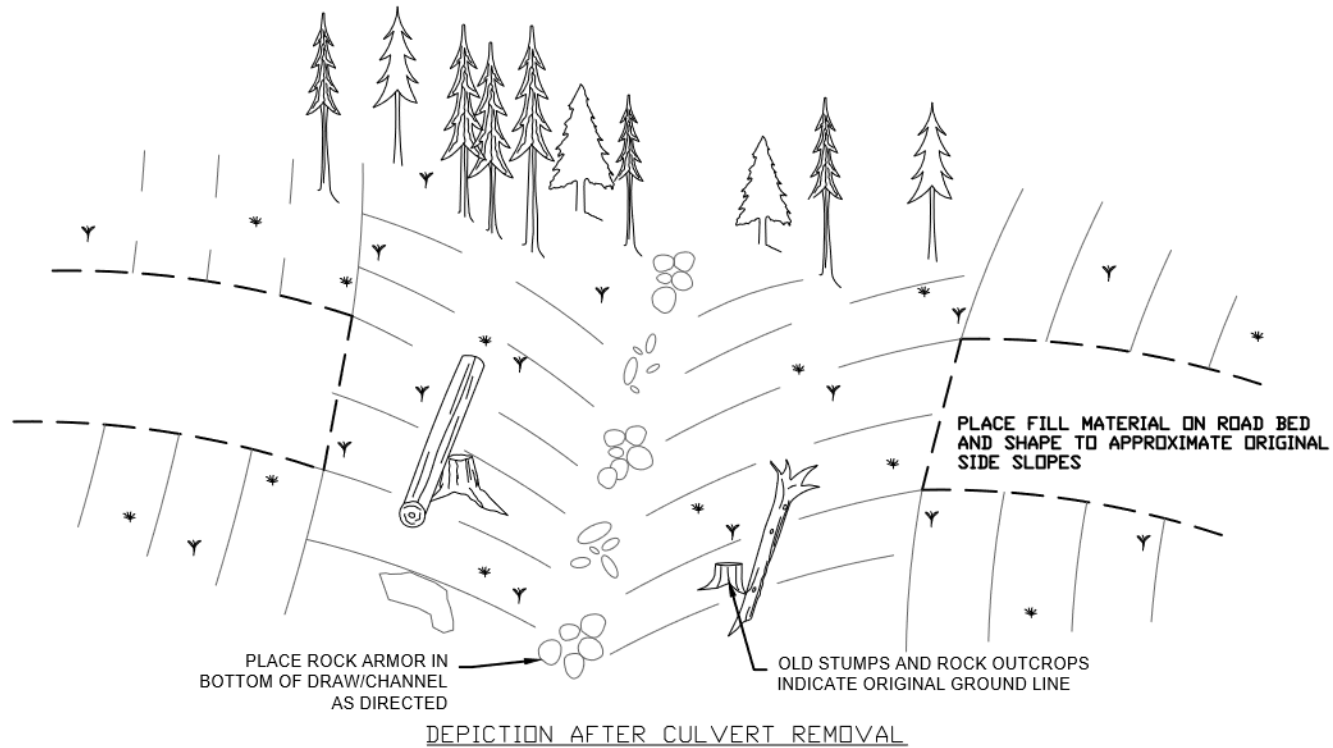

OSU College Forests in Oregon

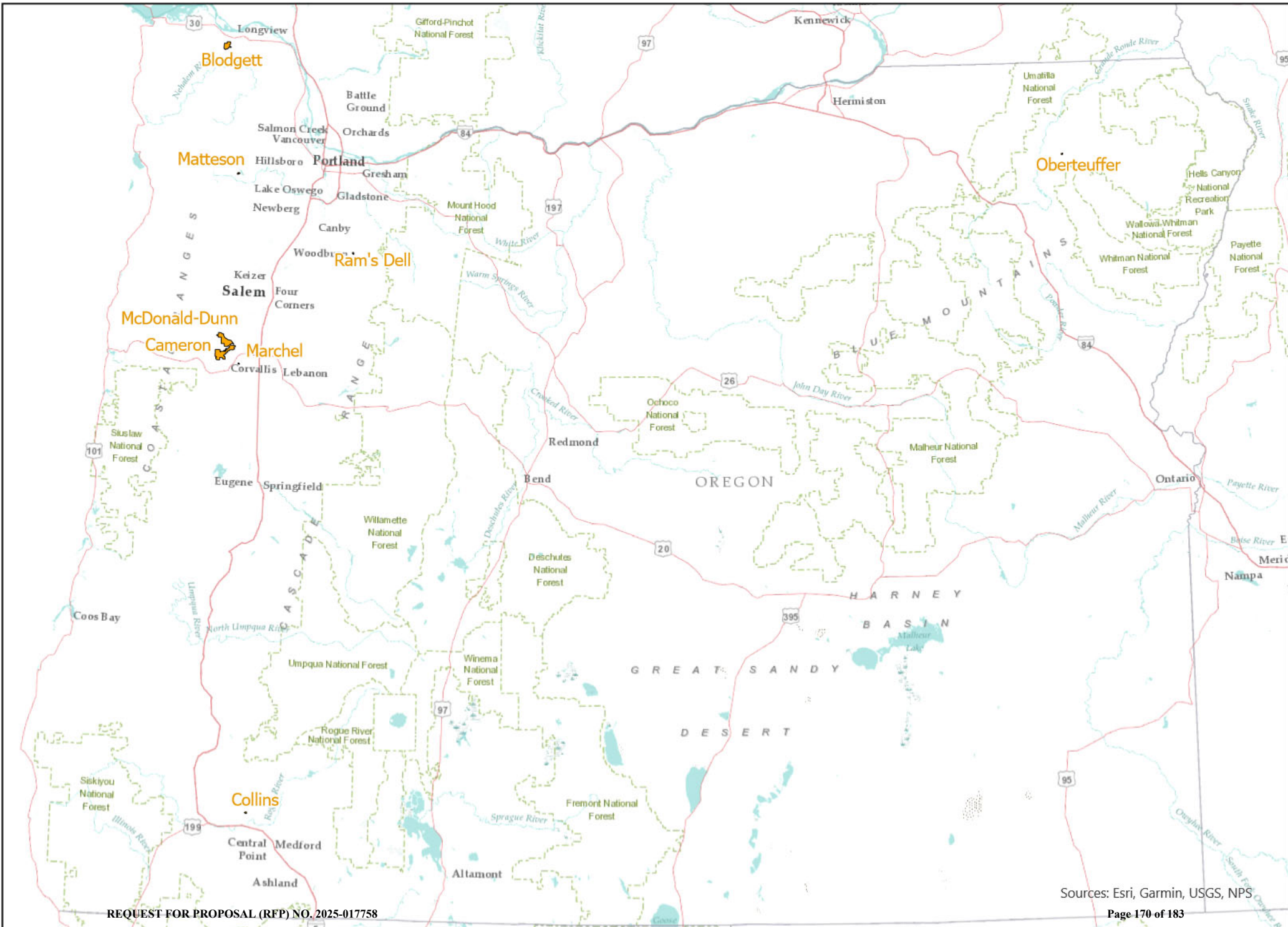

Sources: Esri, Garmin, USGS, NPS

OSU Cameron Forest Benton County, OR

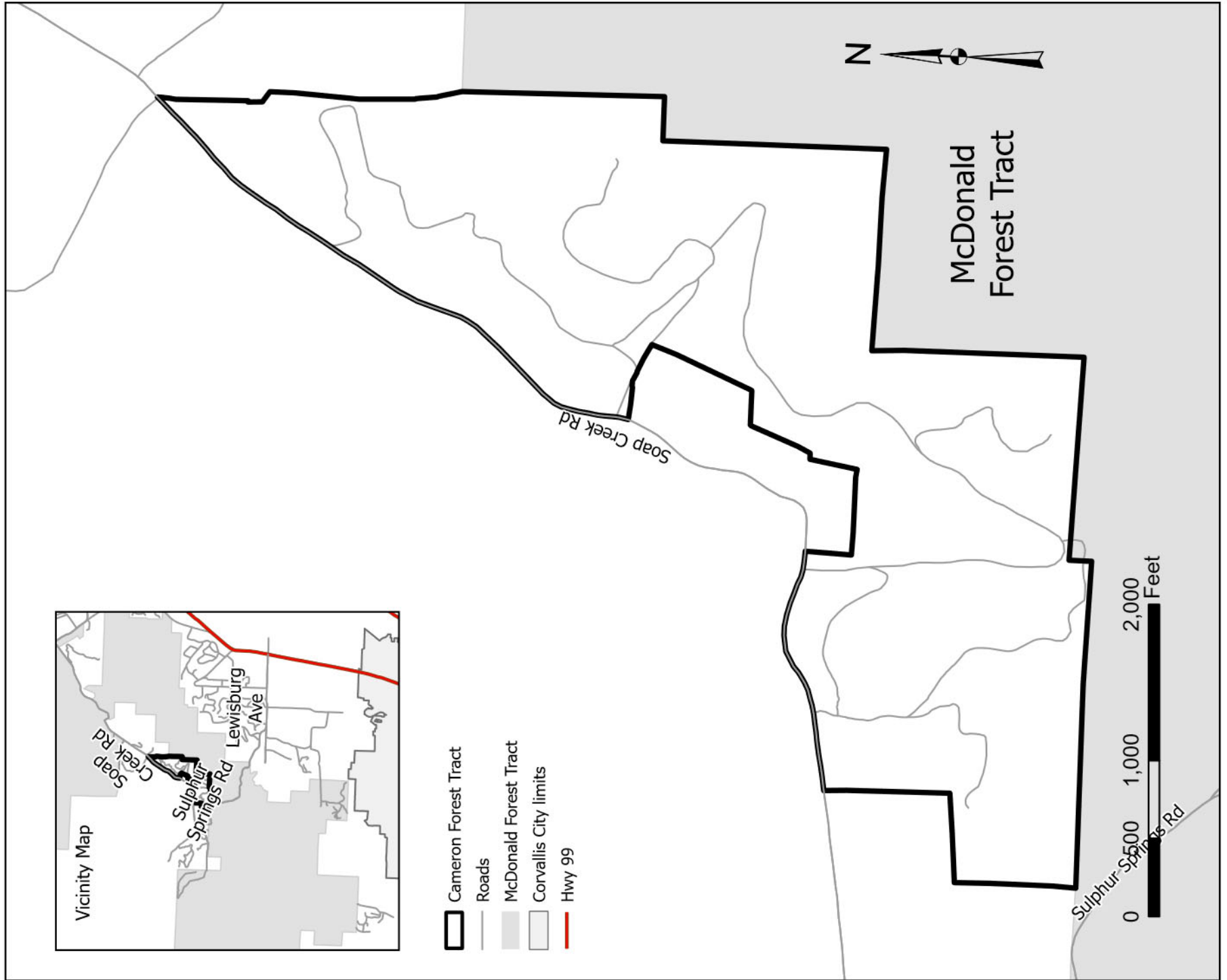

OSU Collins Forest
Jackson County, OR

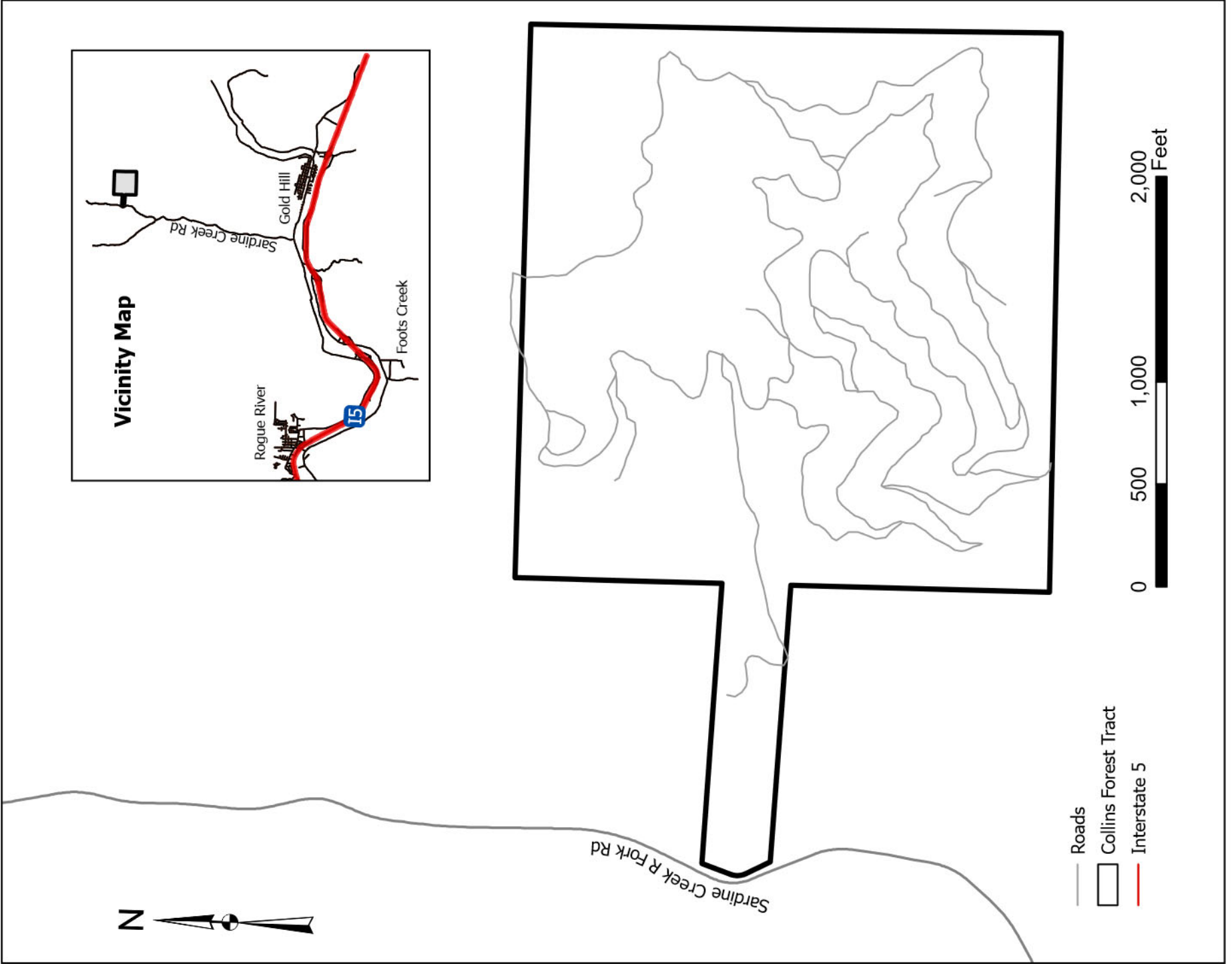

OSU Marchel Forest Benton County, OR

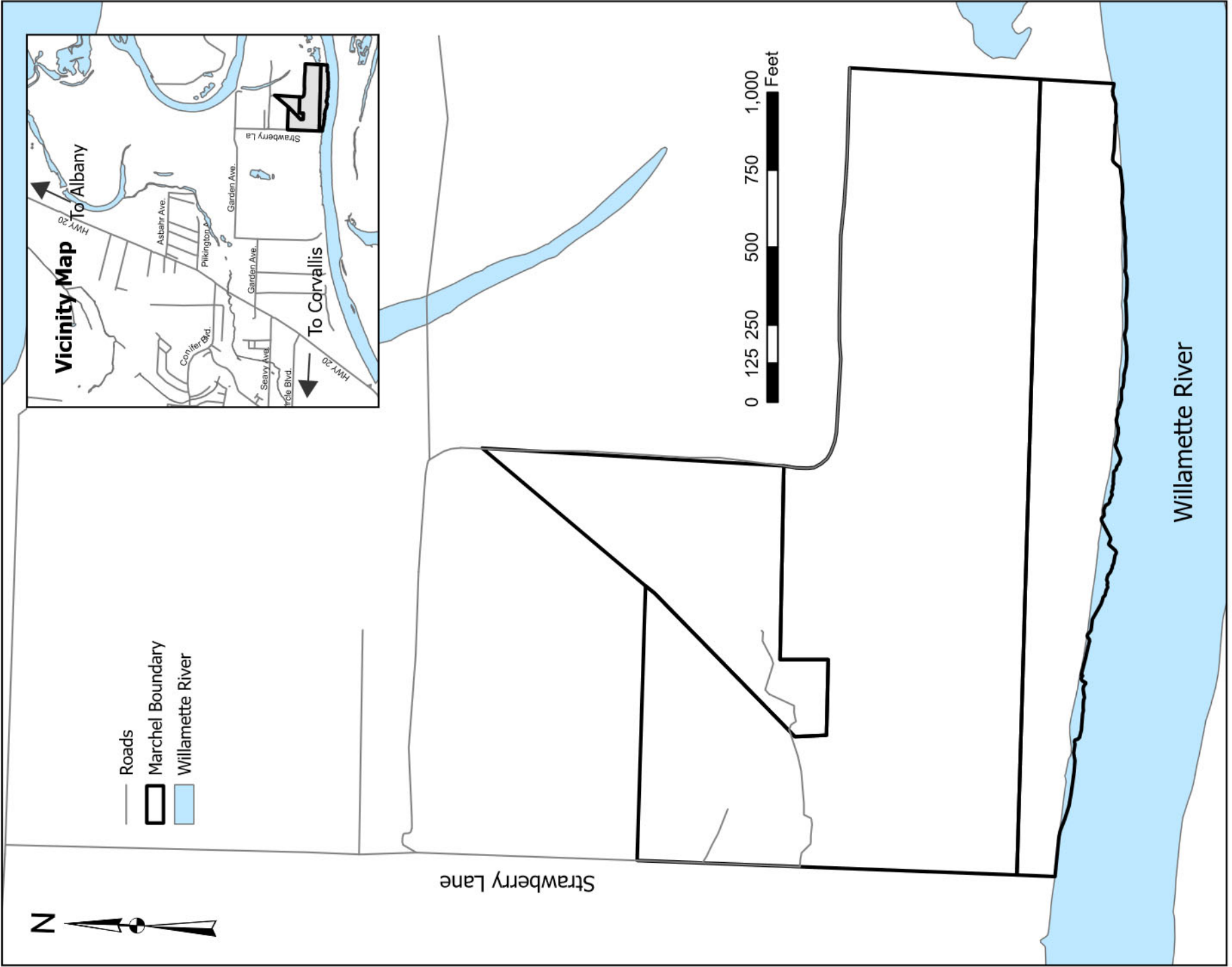

OSU Matteson Forest Washington County, OR

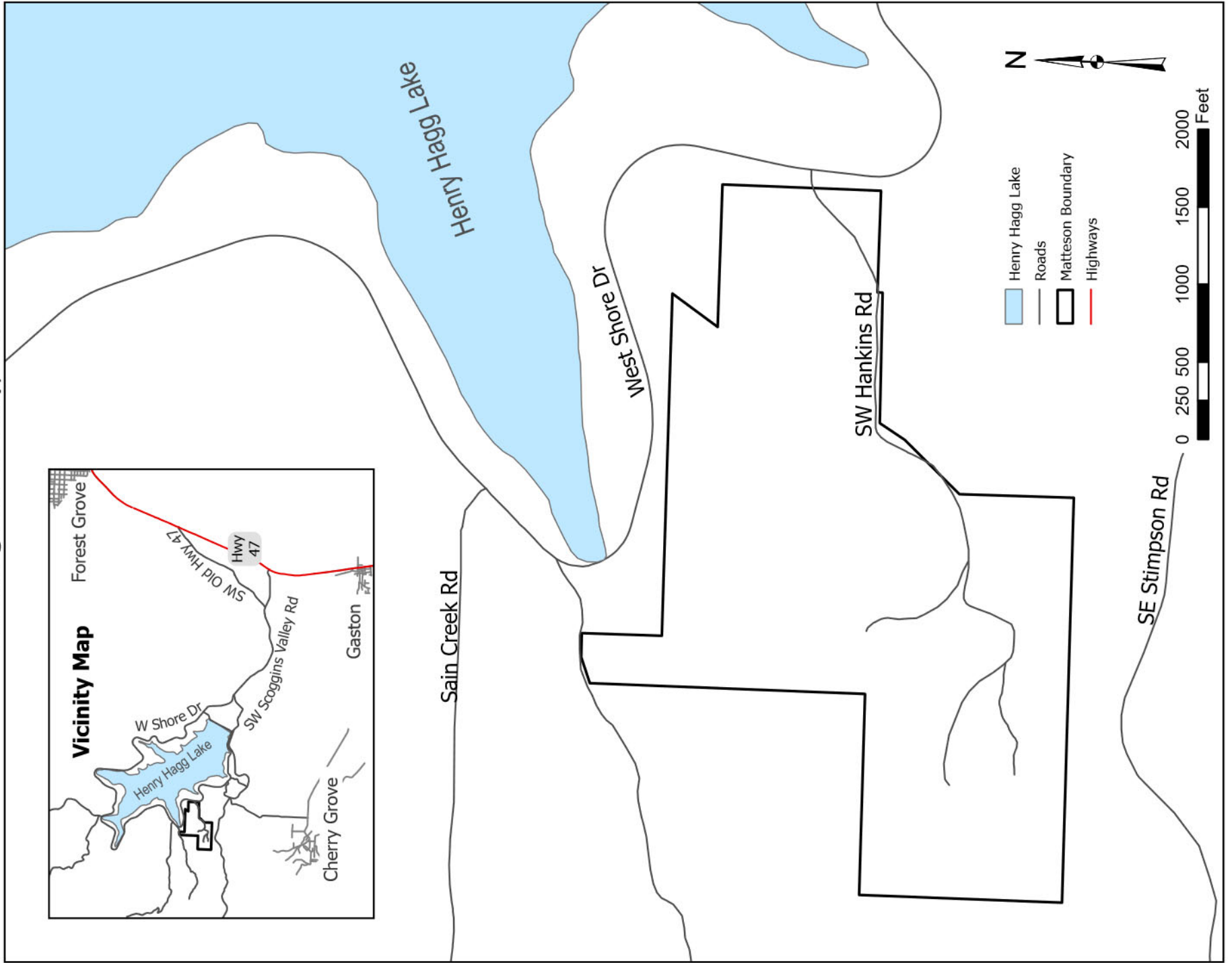

OSU McDonald-Dunn Forest
Benton County, OR

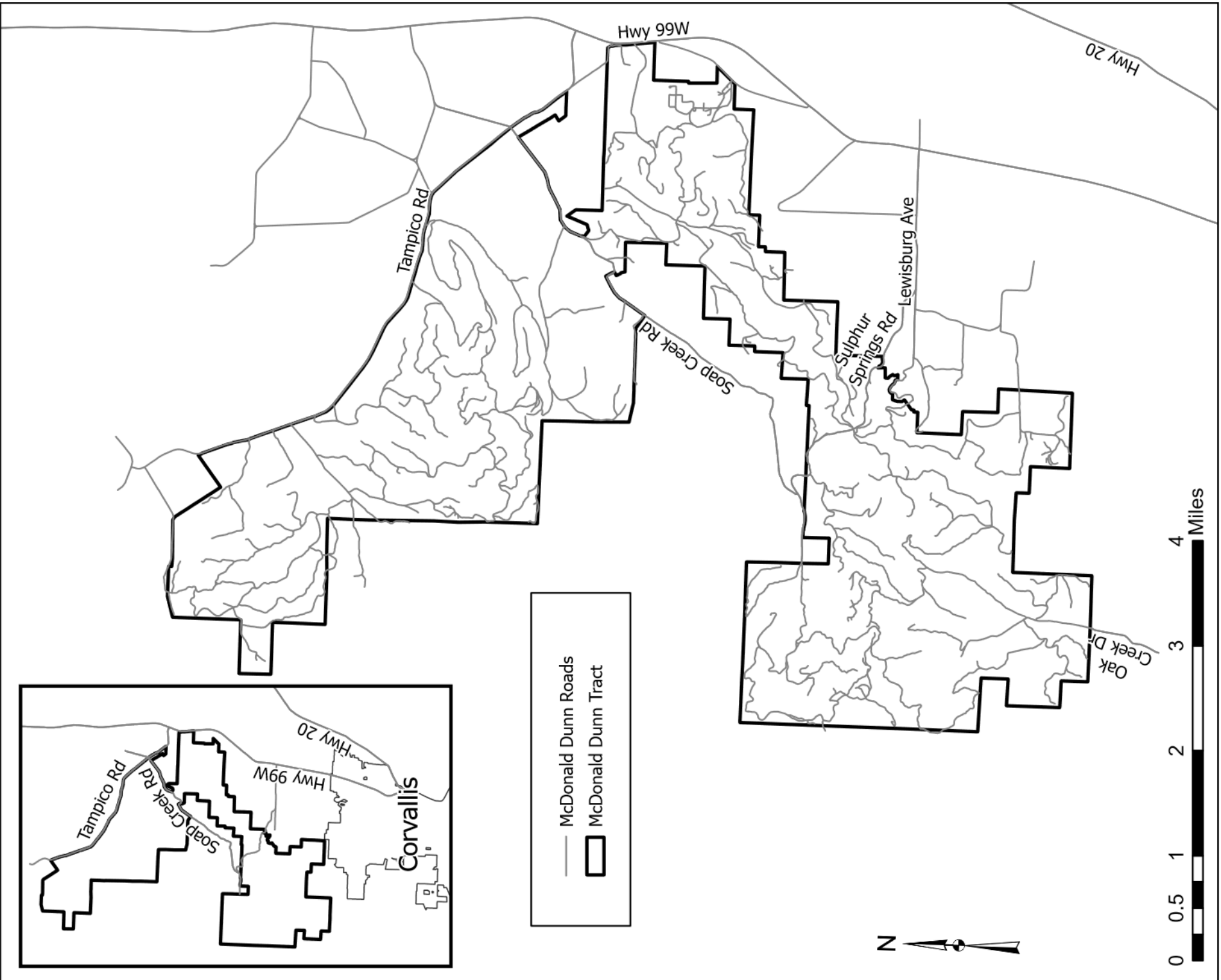

OSU Oberteuffer Forest
Union County, OR

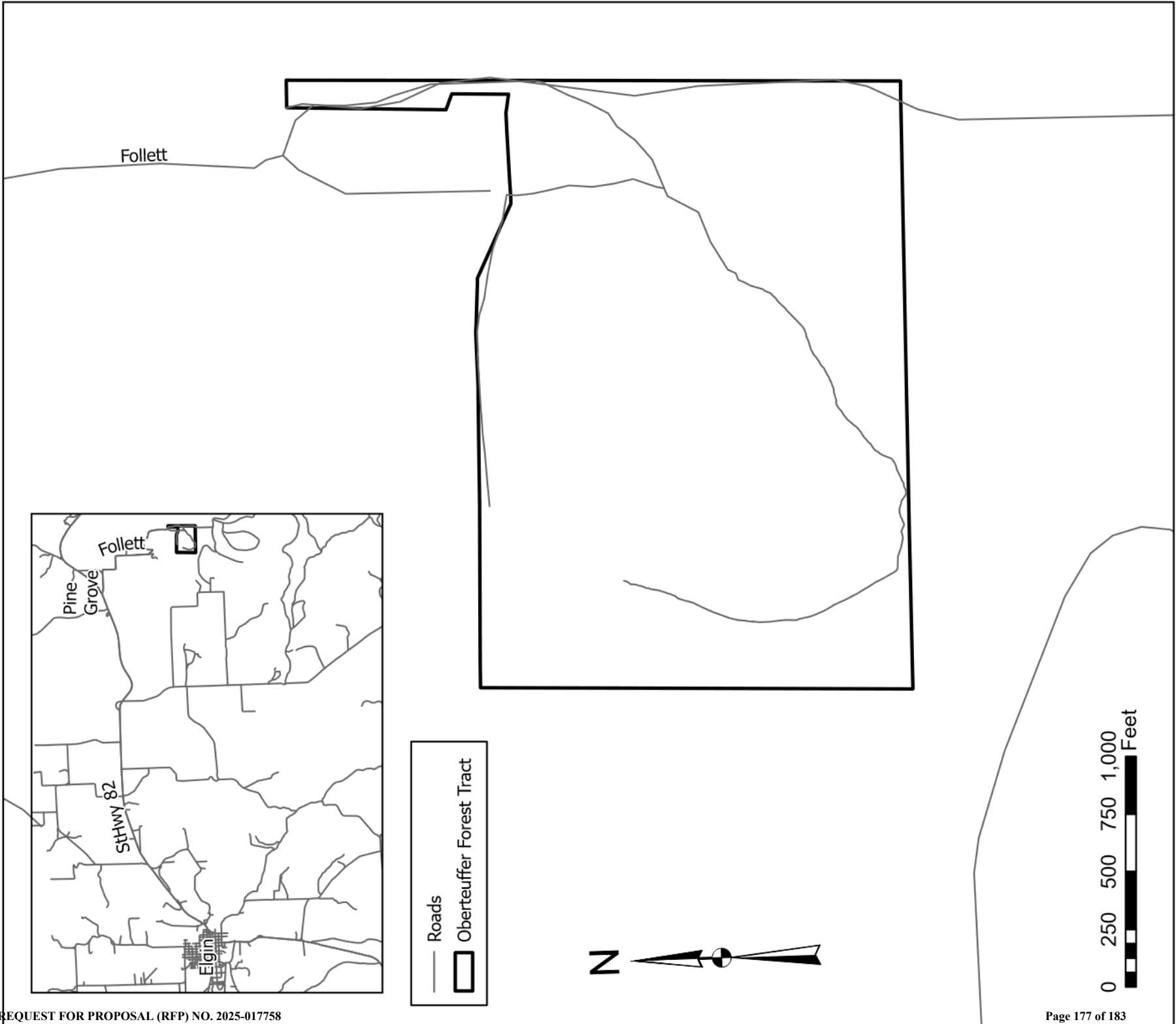

Ram's Dell Clackamas County, OR

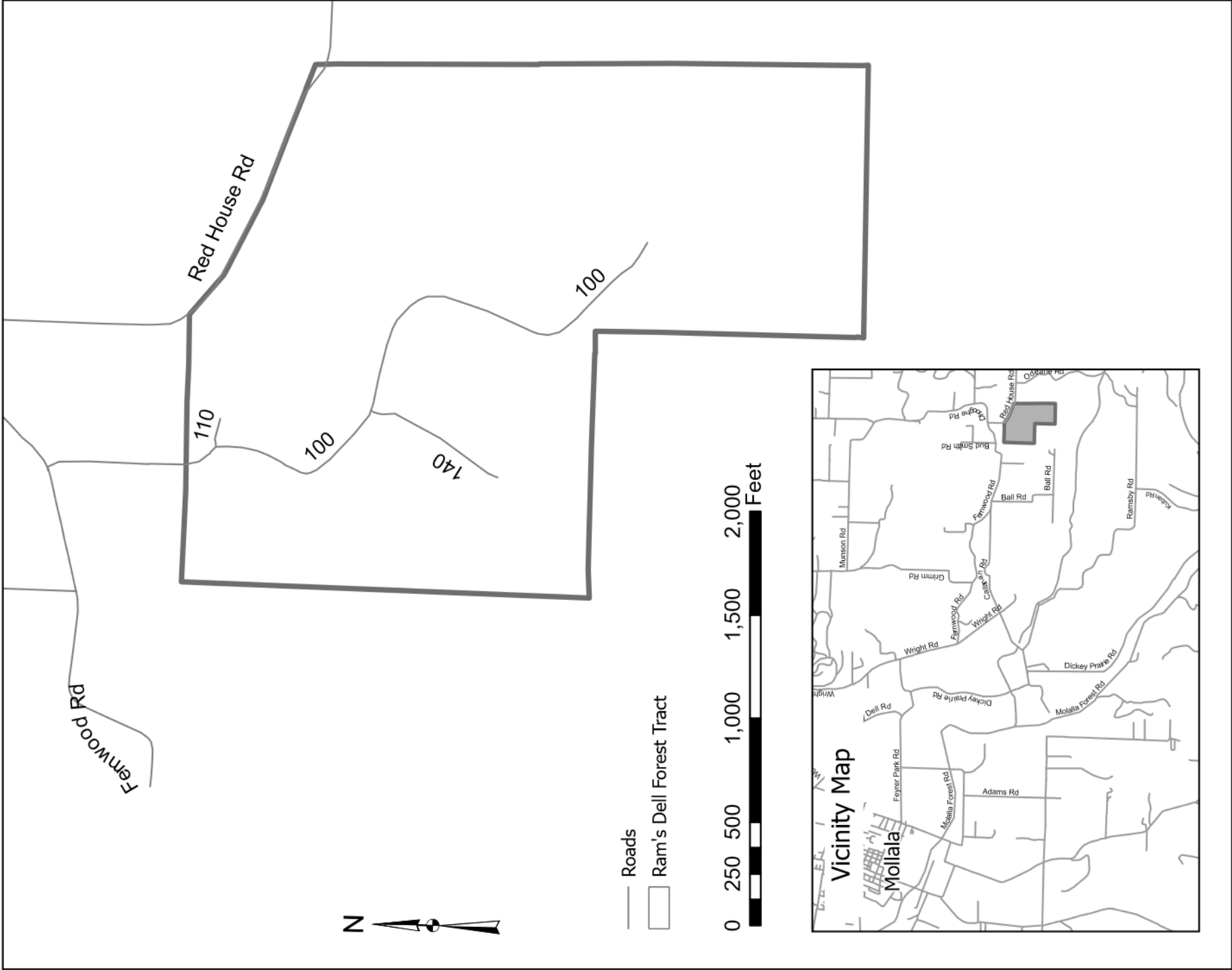

Exhibit 8
Schedule of Items

Includes:
Unit Prices
Schedule of Items

Provide unit prices for the Work listed on the Schedule of Items (attached below) subject to the following requirements:

- A. In the figure for each unit price, include labor, operator, and incidental costs which, as attributable to adjustments in the work of other trades, may be required to achieve the contemplated final conditions.
- B. If there is a question regarding the extent, scope, nature, or intent of the unit price work, contact the Contract Administrator by the question Failure on the part of the Contractor to clarify any unclear items shall not relieve the Contractor of the responsibility for performing the Work in accordance with the intent and requirements of the Contract Specifications or Drawings. Questions will be answered in an addendum. Contractor shall not reach out to anyone other than the Contract Administrator for clarifications.
- C. The description of unit price items listed hereinafter is qualitative. The quantities listed are estimated quantities and are included for the purpose of award of the Contract. Actual quantities of labor and materials required to execute the unit price items of Work will be determined by project conditions and with concurrence of the Owner's Authorized Representative.
- D. The applicable Sections of the Specifications apply to the Work under each unit price item.

Schedule of Items

Item No.	Exhibit or Spec.	Schedule of Items	Qty	Unit	Unit Price	Total Price
1	N/A	Consultation	10	HOUR		
2	Tech Specs 4	Mobilization to Benton County	1	EA		
3	Tech Specs 4	Mobilization to Blodgett Tract	1	EA		
4	Tech Specs 4	Mobilization to Ram's Dell Tract	1	EA		
5	Tech Specs 4	Mobilization to Matteson Tract	1	EA		
6	Tech Specs 4	Mobilization to Collins Tract	1	EA		
7	Tech Specs 7 (C3)	Equipment Cleaning	2	EA		
8	Tech Specs 19	Furnish & Install 18" Culvert	40	LF		
9	Tech Specs 19	Furnish & Install 24" Culvert	40	LF		
10	Tech Specs 19	Furnish & Install 36" Culvert	40	LF		
11	Tech Specs 19	Furnish & Install 48" Culvert	40	LF		
12	Tech Specs 17	Delivered Aggregate 3/8"-minus to Benton County	25	TON		
13	Tech Specs 17	Delivered Aggregate 3/4"-minus to Benton County	25	TON		
14	Tech Specs 17	Delivered Aggregate 1"-minus to Benton County	40	TON		
15	Tech Specs 17	Delivered Aggregate 1"-Open to Benton County	40	TON		
16	Tech Specs 17	Delivered Aggregate 1-1/4"-Open to Benton County	40	TON		
17	Tech Specs 17	Delivered Aggregate 1-1/2"-minus to Benton County	200	TON		
18	Tech Specs 17	Delivered Aggregate 1-1/2" - Open to Benton County	40	TON		

Schedule of Items

Item No.	Exhibit or Spec.	Schedule of Items	Qty	Unit	Unit Price	Total Price
19	Tech Specs 17	Delivered Aggregate 3"-minus to Benton County	200	TON		
20	Tech Specs 17	Delivered Aggregate 4-6" Open to Benton County	40	TON		
21	Tech Specs 17	Delivered Aggregate Jaw Run to Benton County	40	TON		
22	Tech Specs 17	Delivered Aggregate Shot Rock to Benton County	40	TON		
23	Tech Specs 17	Delivered Aggregate Class 700 Rip Rap Benton County	40	TON		
24	Tech Specs 17	Delivered Aggregate Class 700 Rip Rap Blodgett Tract	40	TON		
25	Tech Specs 17	Delivered Aggregate 1 ½"-minus Blodgett Tract	40	TON		
26	Tech Specs 17	Delivered Aggregate 3"-minus Blodgett Tract	40	TON		
27	Tech Specs 17	Delivered Aggregate Jaw Run Blodgett Tract	14	TON		
28	Tech Specs 17	Delivered Aggregate Shot Rock Blodgett Tract	14	TON		
29	Tech Specs 12	Cutting Side Vegetation	1	SIDE MILE		
30	Tech Specs 18 (B)	Blading Surfaced Roads, Compaction B	1	MILE		
31	Tech Specs 18 (B)	Blading Surfaced Roads, Compaction C	1	MILE		
32	Tech Specs 18 (A)	Clean and Reshape Drainage Ditch	1	MILE		
33	Tech Specs 11 (A1)	Dozer	10	HOUR		
34	Tech Specs 11 (A2)	Mini Excavator	10	HOUR		
35	Tech Specs 11 (A3)	Small Excavator	20	HOUR		
36	Tech Specs 11 (A4)	Medium Excavator	40	HOUR		

Schedule of Items

Item No.	Exhibit or Spec.	Schedule of Items	Qty	Unit	Unit Price	Total Price
37	Tech Specs 11 (AS)	Large Excavator	40	HOUR		
38	Tech Specs 11 (AG}	Front End Loader	10	HOUR		
39	Tech Specs 11 (A7}	Backhoe	10	HOUR		
40	Tech Specs 11 (A8)	Grader	40	HOUR		
41	Tech Specs 11 (A9}	Roller	40	HOUR		
42	Tech Specs 11 (A10)	Dump Truck	20	HOUR		
43	Tech Specs 11 (All)	Self-Loading Log Truck	10	HOUR		
44	Tech Specs 11 (A12}	Log Truck	10	HOUR		
45	Tech Specs 11 (AB)	Water Truck	10	HOUR		
46	Tech Specs 11 (A14)	Log Loader	20	HOUR		
47	Tech Specs 11 (AIS}	Brushing Tractor	40	HOUR		
48	Tech Specs 11 (A16)	Trailer Mounted Mulcher	10	HOUR		
49	Tech Specs 11 (A17)	Laborer/Tools	10	HOUR		
50	Tech Specs 11 (B}	Move Equipment, Tilt TopTrailer	5	HOUR		
51	Tech Specs 11 (B)	Move Equipment, Lowboy	5	HOUR		
52	OR Seed Cert. Service	Grass Seed: Annual Rye; Endophyte & Weed Free	100	LB		
53	N/A	Straw Bale, Wheat/ Oat straw, weed free	10	EA		
54	ASTM D6461	Silt Fence, 3-foot height	so	LF		

Schedule of Items

Item No.	Exhibit or Spec.	Schedule of Items	Qty	Unit	Unit Price	Total Price
55	AASHTO M-288-06	Geotextile Fabric, Woven Class 3	200	SY		