



# Portland State University

## Facilities Improvement

Science Building 1  
Cooling Tower Replacement  
Issue for Permit & Construction



EXPIRES: 12/31/13



15 February 2012

## **Table of Contents**

### **Technical Specifications**

#### **PSU Division 1 Documents**

01010	Summary of Work
01027	Application for Payment
01030	Alternates
01040	Project Coordination
	01040.1PSU – Office of Facilities: Project Information Form
	01040.2PSU – Office of Facilities: Construction Project Safety Form
	01040.3PSU – Office of Facilities: Request for Information
	01040.4PSU – Office of Facilities: Construction Directive
01045	Cutting and Patching
01300	Submittals
01400	Quality Requirements
01410	Testing Laboratory Services
01500	Temporary Facilities and Controls
01550	Contractor Parking
01565	Tree Protection
01600	Contractor Staging
01630	Product Requirements and Substitutions
01732	Waste Management
01734	Indoor Air Quality
01780	Contract Closeout

#### **Technical Specifications**

##### **Division 2 – Existing Conditions**

02 41 19	Selective Structure Demolition
02 41 23	Mechanical Demolition
02 41 26	Selective Electrical Demolition

##### **Division 5 – Metals**

05 12 00	Structural Steel Framing
05 50 00	Metal Fabrications

##### **Division 7 – Thermal and Moisture Protection**

07 84 00	Firestopping
----------	--------------

**Division 23 – Heating, Ventilation, and Air Condition**

- 23 05 13 Common Motor Requirements for HVAC Equipment
- 23 05 23 General Duty Valves and Accessories
- 23 05 29 Hangers & Supports for Piping and Equipment
- 23 05 48 Vibration and Seismic Controls for HVAC Piping and Equipment
- 23 05 53 Mechanical Identification for Piping and Equipment
- 23 05 93 Testing, Adjusting, and Balancing for HVAC
- 23 08 00 Commissioning
- 23 09 00 HVAC Instrumentation & Control
- 23 21 13 Hydronic Piping
- 23 21 16 Hydronic Piping Specialties
- 23 25 00 HVAC Water Treatment
- 23 65 00 Cooling Towers

**Division 26 – Electrical**

- 26 05 00 Common Work Results for Electrical
- 26 05 19 Low-Voltage Electrical Power Wire and Cables
- 26 05 26 Grounding and Bonding for Electrical Systems
- 26 05 29 Hangers and Support for Electrical Systems
- 26 05 33 Raceways and Boxes for Electrical Systems
- 26 05 53 Identification for Electrical Systems
- 26 27 26 Wiring Devices
- 26 28 19 Enclosed Switches
- 26 28 23 Enclosed Circuit Breakers
- 26 28 26 Enclosed Transfer Switches
- 26 29 23 Variable Frequency Motor Controllers

## SECTION 01010 SUMMARY OF WORK

### PART 1 -GENERAL

#### 1.01 WORK COVERED BY THE PROJECT MANUAL AND DRAWINGS

- A. Work covered by the Project Manual and Drawings consists of Cooling Tower Replacement Improvements SB1 (The terms "Owner", "PSU", and "University" are interchangeable)
- B. The work includes:
  - 1. Science Building 1 (SB) Cooling Tower Replacement
  - 2. New piping for above roof installation designed and installed and painted by the contractor
  - 3. Demolition of existing SB1 cooling tower and associated piping
  - 4. New side stream cleaning system as specified in the contract documents
  - 5. Structural support of new cooling tower as provided in the contract drawings
  - 6. Electrical supply to new equipment in the SB1 Cooling Tower replacement project from existing panels as noted on the contract drawings
  - 7. Alternatives to either epoxy line the existing remaining piping system from and to the new piping at the Cooling Tower on the roof all the way from and to the chiller being served in the sub basement or replacing all of the piping with 6" or 8" carbon steel piping
  - 8. Replacement of indicated control valves on the condenser water system and chilled water system indicated on the contract drawings
  - 9. System Control elements are to be removed and replaced in similar locations as noted in the contract documents.
  - 10. New control elements indicated on the contract documents shall be provided and installed and wiring completed.
  - 11. Controls Sequence of Operation and Programming and Commissioning will be provided by PSU.
  - 12. Assist PSU in obtaining building permits.
- C. The Contractor shall supply all labor, transportation, parking, apparatus, scaffolding, tools and other items necessary for the completion of the work in conformance with OUS General Conditions for Public Improvements Contracts, Section A.2.
- D. The Work shall be started within ten (10) calendar days following approval of the Contractor's Certificate of Insurance and the Execution of Contract by PSU Facilities, attention (contract coordinator). All work shall be final completed within the time frames established in the Public Improvement Agreement Form (OUS Contract Form B-7, Item 4). *Time is of an essence on this project.* Failure to complete the project within the time specified will result in damages to the Owner. The Contractor will be charged liquidated damages in accordance with Item 5 of the Public Improvement Agreement Form (OUS Contract Form B-7). Liquidated damages will be deducted from the Contractor's Final Payment Request.

#### 1.02 CONTRACTOR'S USE OF PREMISES

- A. Contractor shall limit use of the Premises for Work and storage to allow for:



1. Owner and tenant occupancy of adjacent spaces, day and night
  2. Public use, day and night
  3. Security
  4. Safe entry and exit for vehicles and pedestrians
- B. Access through the interior of the building will be coordinated with the Owner's Authorized Representative.

### 1.03 PROTECTIONS

- A. Protect sidewalks, asphalt paving, concrete, trees, shrubs, and lawn areas at all times from spillage of materials used in carrying out the Work. Prevent materials from clogging sinks, catch basins and yard drains; maintain drains clean and in proper working conditions. Dumping of plaster, solvents, or other injurious materials in PSU plumbing systems is not permitted. Costs of cleaning or repair will be withheld from Contractor as required.
- B. Clean, repair, resurface, or restore existing surfaces to their original, or better, condition, or completely replace such surfaces to match existing, where damaged by construction operations.
- C. The Contractor shall be responsible for any and all damages as specified in OUS General Conditions for Public Improvement Contracts Section G.1.1.
- D. The Owner will not be responsible for protection of materials or equipment from vandalism or theft. Security is the responsibility of the Contractor. See Section 01500 Temporary Facilities.
- E. The Contractor will verify that all drains in the construction area are in working order and notify the Owner's Representative, in writing, of any drains that are plugged, prior to the Start of Work. Start of Work will be considered as acknowledgement that all drains are clear and in good working order.
- F. Debris shall not be allowed to remain around the buildings during performance of Work, and shall be disposed of daily and/or as directed by Owner's Authorized Representative.
- G. The Contractor shall manage a safe job environment for both the safety of all people around the Premises as well as the safety of the Owner's and general public's property.
- H. Do not store materials where they will interfere with operations of Owner. Storage areas must be approved by the Owner's Authorized Representative prior to start of the Work.

### 1.04 OWNER OCCUPANCY

- A. The Owner and building tenants will occupy the Premises during the entire period of construction for the conduct of normal operations. Cooperate and coordinate with Owner's Authorized Representative in construction operations to minimize conflict and to facilitate the Owner's usage, especially in the following areas:
1. Restricted access and parking
  2. Use of elevators and stairs
  3. Temporary storage space availability

4. Provide a written schedule of Work specifying where and when Work will be accomplished
  5. Notify Owner's Authorized Representative a minimum of seventy-two (72) hours prior to performing any work that will release strong odors or fumes, causes noise, or requires windows to be closed during hot weather. See Section 01734 for additional Indoor Air Quality requirement, which includes coordination of noise abatement.
- B. Conduct operations in such a way to ensure the least inconvenience to University staff, students and the general public.
- C. To maintain continual operations by the Owner and building tenants, evening and/or weekend work by the Contractor will be required for short durations at various stages of the Project. Coordinate with the Owner's Authorized Representative at least seventy-two (72) hours in advance to performing evening or weekend work.

#### 1.05 SALVAGE

- A. All material indicated to be removed shall become the property of the Contractor except those items noted on the drawings and in the specifications as being retained by the Owner.
- B. All locksets, cylinders and strikes removed shall be returned to Owner. Coordinate with Owners Authorized Representative.
- C. The City of Portland has mandated the recycling of demolition materials. See Section 01732 of these Specifications for Waste Management requirements, which includes recycling documentation to be provided to the Architect and Owner by the Contractor.

### **PART 2 -PRODUCTS**

#### 2.01 REUSE OF EXISTING MATERIAL

- A. Except as specifically indicated or specified, materials and equipment removed from existing construction shall not be used in the completed Work.
- B. For material and equipment specifically indicated or specified to be reused in the Work or salvaged to Owner:
1. Use special care in removal, handling, storage, and reinstallation to assure proper function in the completed Work.
  2. Arrange for transportation, storage, and handling of products that require off-site storage, restoration or renovation. Pay all costs for such Work.
  3. Contractor shall be responsible for removing and reinstalling mechanical units, vents, guys, antennae, and electrical and grounding wires or conduits.

### **PART 3 -EXECUTION**

#### 3.01 PREPARATION

- A. Inspect existing conditions, Work requirements, and the Contract Documents. Verify that materials and equipment being furnished meet requirements specified. Report any discrepancies to the Owner's Authorized Representative prior to proceeding with work.

### 3.02 MATERIAL HANDLING

- A. If, in the opinion of the Contractor, cranes, hoists, towers, or other lifting devices are necessary for the proper and efficient movement of materials, comply with these requirements:
  - 1. Use only experienced personnel
  - 2. Remove equipment as soon as possible after task is ended
  - 3. Coordinate the placement of such equipment with the Owner's Authorized Representative to ensure that utility tunnels, utilities, and surfaces are not damaged.
  - 4. Obtain required permits and meet the requirements of governing authorities regarding street and sidewalk closures, safety, noise, and other applicable regulations.
  - 5. Provide barricades and warning ribbons to close off areas temporarily for loading and unloading, to insure public safety.
- B. Contractor shall not allow any materials or debris to free-fall from the building.

### 3.03 WORKMANSHIP

- A. Unless otherwise specified, perform the Work using workers skilled in the particular type of Work involved.
- B. Should the Owner or the Architect, in writing, deem anyone on the Work incompetent or unfit for the assigned duties, dismiss the worker immediately or reassign that worker to a different task requiring a lesser degree of competence.
- C. Workmanship shall be first class in every respect as determined by the Owner's Authorized Representative and Architect, and all Work performed shall be performed in accordance with standard industry practice.
- D. The Contractor shall maintain effective supervision on the project at all times Work is being performed. The Superintendent shall be the same person throughout the course of the Work, and shall attend the pre-construction conference.

### 3.04 TESTING

- A. The Owner reserves the right to perform any testing as may be required to determine compliance with the Project Manual and Drawings. Costs for such testing will be the Owner's responsibility unless testing indicates noncompliance. Costs for testing which indicates noncompliance shall be borne by the Contractor. Non-complying Work shall be corrected and testing will be repeated until the Work complies with the Project Manual and Drawings. Contractor will pay costs for retesting non-complying Work.
- B. The Contractor shall cooperate in every respect with the activities of the testing agency.

END OF SECTION

**SECTION 01027**  
**APPLICATIONS FOR PAYMENT**

**PART 1 -GENERAL**

1.01 DESCRIPTION

- A. Work of this Section includes procedures for progress payments.
- B. Related work specified elsewhere:
  - 1. For the primary discussion of payments, refer to Article E of OUS General Conditions for Public Improvement Contracts and Supplemental General Condition SG-3.

**PART 2 -PRODUCTS**

2.01 APPLICATION FORMS

- A. For applications for payment, use AIA Document G702, Application and Certificate for Payment, supported by AIA Document G702a, Continuation Sheet.
- B. Prepare the Schedule of Values in such a manner that each major item of Work and each subcontracted item of Work is shown as a line item costs broken down to correspond to the project construction schedule as detailed in Article H.2.1 of the OUS General Conditions for Public Improvement Contracts on AIA Document G702a, Application and Certification of Payment, Continuation Sheet. The Continuation Sheet shall be the minimum Schedule of Values breakdown.

**PART 3 -EXECUTION**

3.01 PAYMENTS

- A. The Owner will make progress payments on the account of the Contract once a month, based on the value of Work accomplished or materials on the Premises, as stated in the Schedule of Values on the Application and Certificate for Payment. Complete and forward three (3) copies of the Application and Certificate for Payment to the Architect by the 20th day of each month.
- B. Payments will be made on protected materials on hand on the Premises properly stored, protected, and insured. Estimated quantities shall be subject to the Architect's review and judgment.

END OF SECTION

## **SECTION 01030 ALTERNATES**

### **PART 1 - GENERAL**

#### 1.01 DESCRIPTION

- A. Work of the Section includes administrative and procedural requirements to the Bid Alternates of the OUS Bid Form (OUS Form B-6).

#### 1.02 RELATED WORK IN OTHER SECTIONS

- A. Additional information regarding bid alternates and changes in scope may be found in the follows:
  - 1. OUS Bid Form
  - 2. Instructions to Bidders
  - 3. OUS General Conditions
  - 4. Other Sections of these specifications.

#### 1.03 DEFINITION

- A. An alternate is an amount proposed by bidders and stated on the Bid Form for certain work defined in the Project Manual that may be added or deducted from the Basic Bid amount if the Owner decides to accept a corresponding change in the amount of construction to be completed, or in the products, materials, equipment, systems, or installation method.
- B. The cost change for each alternate is the net addition to or deletion from the Basic Bid to incorporate the alternate into the work. No other adjustments are made to the Basic Bid, unless stipulated in the Instructions to Bidders or the OUS General Conditions for Public Improvement Contracts.

### **PART 2 - ACCEPTANCE OF ALTERNATIVES**

#### 2.01 GENERAL

- A. The Owner's initial intent is to contract for all work of the Basic Bid. All required bonding, deposits, securities or guarantees required by the Contract Documents shall be based on the Basic Bid amount.
- B. Alternates quoted on the Bid Form will be reviewed and may be rejected, accepted individually, in combination or entirely at the Owner's Option.
- C. Alternates to the Basic Bid will be executed by a Change Order, in accordance with Division 1 Section 01300 and the OUS General Conditions for Public Improvement Contracts Section D.
- D. Include as part of each alternate, miscellaneous devices, accessory objects, and similar items incidental to or required to complete the alternative work and surrounding modifications whether or not mentioned as part of the work.
- E. Coordinate related work and modify surrounding work to integrate the work of each alternative.

- F. A "Schedule of Bid Alternates" is provided at the end of this Section. Refer to other Specification Sections of this Project Manual for materials necessary to achieve the Work described under each alternate.

### **PART 3 - SCHEDULE OF BID ALTERNATES**

#### **3.01 ALTERNATES**

- A. The following Alternates may added to the Work of the Base Bid:

- ABI-1 Epoxy lining of indicated condenser water piping from and to the new piping at the Cooling Tower from and to the chiller in the sub basement serving the cooling tower in SB1.
- ABI-2 Replacement of the existing piping with 6" schedule 40 carbon steel piping noted to be lined in ABI 1 including design, supports, materials, and painting
- ABI-3 Replacement of the existing piping with 6" schedule 40 carbon steel piping noted to be lined in ABI 1 including design, supports, materials, and painting
- ABI-4 Replacement of two cooling coil replacement control valves indicated on the drawings in the sub basement of SB1

END OF SECTION

## **SECTION 01030 ALTERNATES**

### **PART 1 - GENERAL**

#### 1.01 DESCRIPTION

- A. Work of the Section includes administrative and procedural requirements to the Bid Alternates of the OUS Bid Form (OUS Form B-6).

#### 1.02 RELATED WORK IN OTHER SECTIONS

- A. Additional information regarding bid alternates and changes in scope may be found in the follows:
  - 1. OUS Bid Form
  - 2. Instructions to Bidders
  - 3. OUS General Conditions
  - 4. Other Sections of these specifications.

#### 1.03 DEFINITION

- A. An alternate is an amount proposed by bidders and stated on the Bid Form for certain work defined in the Project Manual that may be added or deducted from the Basic Bid amount if the Owner decides to accept a corresponding change in the amount of construction to be completed, or in the products, materials, equipment, systems, or installation method.
- B. The cost change for each alternate is the net addition to or deletion from the Basic Bid to incorporate the alternate into the work. No other adjustments are made to the Basic Bid, unless stipulated in the Instructions to Bidders or the OUS General Conditions for Public Improvement Contracts.

### **PART 2 - ACCEPTANCE OF ALTERNATIVES**

- 3.01 The Owner's initial intent is to contract for all work of the Basic Bid. All required bonding, deposits, securities or guarantees required by the Contract Documents shall be based on the Basic Bid amount.
- 3.02 Alternates quoted on the Bid Form will be reviewed and may be rejected, accepted individually, in combination or entirely at the Owner's Option.
- 3.03 Alternates to the Basic Bid will be executed by a Change Order, in accordance with Division 1 Section 01300 and the OUS General Conditions for Public Improvement Contracts Section D.
- 3.04 Include as part of each alternate, miscellaneous devices, accessory objects, and similar items incidental to or required to complete the alternative work and surrounding modifications whether or not mentioned as part of the work.
- 3.05 Coordinate related work and modify surrounding work to integrate the work of each alternative.
- 3.06 A "Schedule of Bid Alternates" is provided at the end of this Section. Refer to other Specification Sections of this Project Manual for materials necessary to achieve the Work described under each alternate.

### **PART 3 - SCHEDULE OF BID ALTERNATES**

4.1 The following Alternates may added to the Work of the Base Bid:

ABI-1 Epoxy lining of indicated condenser water piping from and to the new piping at the Cooling Tower from and to the chiller in the sub basement serving the cooling tower in SB1.

ABI-2 Replacement of the existing piping with 6" schedule 40 carbon steel piping noted to be lined in ABI 1 including design, supports, materials, and painting

ABI-3 Replacement of the existing piping with 6" schedule 40 carbon steel piping noted to be lined in ABI 1 including design, supports, materials, and painting

ABI-4 Replacement of two cooling coil replacement control valves indicated on the drawings in the sub basement of SB1

END OF SECTION



**SECTION 01040  
PROJECT COORDINATION**

**PART 1 -GENERAL**

1.01 DESCRIPTION:

- A. This Section includes administrative and supervisory requirements necessary for coordinating contract documentation, communications and construction operations. The requirements of this Section relate to all work by the Contractor and Sub-contractors performing work under these Contract documents including, but not limited to, the following:

1. Pre-construction Coordination
2. Identification of Owner's Authorized Representatives
3. Identification of Architect
4. Listing of Sub-contractors
5. Contractor Emergency Contact Information
6. Safety & Emergency Procedures
7. Unforeseen Hazardous Materials
8. Permits and Fees
9. Key Requests
10. Progress Meetings
11. Requests for Clarifications & Information
12. Construction Directives
13. Construction Change Orders

1.02 RELATED WORK IN OTHER SECTIONS:

- A. Additional requirements related to Project Coordination may be found in the following:
1. Instructions to Bidders
  2. OUS General Conditions
  3. Other Sections of these specifications.

**PART 2 -PRODUCTS**

NOT USED

**PART 3 -EXECUTION**

3.01 PRE-CONSTRUCTION CONFERENCE

- A. A pre-construction conference shall predate the Work and shall include but not be limited to the following agenda:
1. Contract management and communication requirements
  2. Emergency phone numbers
  2. Record maintenance requirements
  3. Work schedule
  4. Schedule of values
  5. Submittal schedule
  6. Early purchase, long lead items and owner procurements
  7. Multiple contract coordination
  8. Maintenance of access and use of the premises

9. Traffic control, parking and contractor's use of the job site
  10. Hazardous materials
  11. Job site safety
  12. Job site inspection & observation requirements
  13. Review of contract documents
  14. Progress meetings
  15. Other subjects of interest desired by the Contractor, Architect, Owner's Authorized Representative(s), Manufacturer's Representatives, and other participants.
- B. Refer to Division 1, Section 01300 for submittals required prior to the pre-construction conference.
  - C. Coordinate all operations with the Owner's Authorized Representative during the construction period.
  - D. Submit to the Owner's Authorized Representative for approval, a schedule of Values for the Work to be performed; schedule of values shall include project and building name, when the Work is to begin, and estimated duration of the Work. The Schedule of Values is to be provided to the Owner's Authorized Representative in accordance with OUS Supplemental General Condition SG-3.
  - E. Submit to the Owner's Authorized Representative for approval, a schedule for the Work to be performed; schedule shall include project and building name, when the Work is to begin, and estimated duration of the Work. The Schedule is to be provided to the Owner's Authorized Representative in accordance with OUS Supplemental General Condition SG-5. The schedule shall be specific as to which portion of the Work is taking place on a particular day.
  - F. Prior to start of any work, Contractor shall provide at the pre-construction meeting an emergency responsible person/contact list on a 24-hour, "7 day a week" basis for any emergency issue that may arise in connection with this project. Contractor must reissue the list any time the responsible person(s) changes. Issue to Owner's Authorized Representative. See Project Information Sheet provided herein.
  - G. Parking will not be provided on the premises. See Section 01500 Temporary Facilities.
  - H. Schedule elevator usage with the Owner's Representative a minimum of 72 hours in advance so as not to inconvenience the public.

### 3.02 IDENTIFICATION OF OWNER'S AUTHORIZED REPRESENTATIVE

- A. The Owner's Project Manager and the Owner's Field Construction Manager (Jointly the Owner's Authorized Representative or his designee) will be appointed by the Owner and identified at the Pre-construction meeting. The Owner's Authorized Representative in conjunction with the Architect will provide coordination during construction and on-site observation. See Project Information Sheet provided herein.

### 3.03 IDENTIFICATION OF ARCHITECT

- A. The Owner has contracted with Winzer & Kelly to prepare construction documents and assist in Owner's Authorized Representative in the coordination of the construction project. See Project Information Sheet provided herein.

### 3.04 LISTING OF SUB-CONTRACTORS

- A. Provide to the Owner's Authorized Representative at the pre-construction conference three (3) copies of list of sub-contractors anticipated to perform work on the project. Provide on the list of sub-contractors: subcontractor's name, contact person, mailing address and telephone number. Substitution shall be permitted only with the approval of the Owner's Authorized Representative.

### 3.05 CONTRACTOR EMERGENCY CONTACT INFORMATION

- A. Provide to the Owner's Authorized Representative at the pre-construction conference Contractor Emergency Contact telephone numbers. See Project Information Sheet provided herein.

### 3.06 SAFETY AND EMERGENCY PROCEDURES

- A. The Contractor shall be responsible for maintaining a safe job site at all time, until the Owner takes possession. The Contractor shall comply with all safety regulations, and for enforcing compliance with all safety regulations and procedures by all workers, sub-contractors and visitors on the site.
- B. Refer to Division 1, Section 01500 for minimal temporary facilities required for job site safety. The Contractor shall provide procedures and additional temporary facilities as required.
- C. The Contractor shall maintain indoor air quality and noise control standards specified in Division 1, Section 01734.
- D. The Contractor shall complete and submit the Owner's Authorized Representative, at the pre-construction conference the "Construction Project Safety Form" provided herein.

### 3.07 UNFORESEEN HAZARDOUS MATERIAL

- A. Asbestos: The Owner has exercised due diligence in the identification and removal of asbestos containing materials from the work area. Prior to each phase of construction the Contractor shall confirm the non-existence of asbestos containing materials in the work area prior to proceeding. If the Contractor identifies materials suspected of containing asbestos, he shall immediately stop work in that area of the job site and proceed in accordance with Division 1, Section 01732, Item 3.01(F).
- B. Lead Paint: The Owner has exercised due diligence in the identification and removal of lead paint from the work area. Prior to each phase of construction the Contractor shall confirm the non-existence of materials coated with lead based paint in the work area prior to proceeding, as required in accordance with OSHA Directive CPL 2-2.58. If lead based paint materials are suspected, the contractor shall immediately notify the Owner's Authorized Representative and proceed in accordance with OSHA Standards and Directives. If required an adjustment in the Contract Sum and Contract Time will be made through Execution of a Contract Change Order in Accordance with OUS General Conditions for Public Improvement Contracts Section D.1.3(c).

### 3.08 PERMITS & FEES

- A. The Campus Loop project is enrolled in the city of Portland's Facilities Permit Program. See OUS Standard General Conditions and Supplementary General Conditions.

- B. The Owner shall provide Building, Electrical, Mechanical and Plumbing permits for buildings in accordance with OUS Supplemental Condition SG-2. If the Contractor needs to block a portion of the right-of-way, the Contractor must secure the proper permits from the City of Portland and shall give all requisite notices to public authorities. The Contractor shall be responsible for all violations of the law for any cause in connection with the Work or caused by obstructing streets or sidewalks.
- C. The Contractor shall provide proper notice to all governing jurisdictions including but not limited to the Oregon Department of Environmental Quality prior to beginning work.
- D. Contractor shall pay for and document Oregon Bureau of Labor and Industries fees as required by Bureau of Labor & Industry.

### 3.09 KEY REQUESTS

- A. Keys will be provided to the Contractor as required for access to buildings and work areas. There is a deposit of \$100.00 required for each key given to the Contractor. Contractor shall fill out Contractor's key request form and deliver for approval to Project Manager a minimum of 48 hours in advance. This deposit will be refunded upon return of the key(s.) Keys will not be provided to sub-contractors, nor will Facilities open locked doors for Contractor's employees or sub-contractors. Contractor shall provide and coordinate all such requirements.

### 3.10 PROGRESS MEETINGS

- A. The contractor shall schedule for the contractor's Project Manager and Field Superintendent to attend weekly Progress Meetings with the Architect and the Owner's Authorized Representative. The contractor shall coordinate and assure the attendance of sub-contractors as required by the agenda and the Owner's Authorized Representative.
- B. Weekly Progress Meetings shall be held each(day and time), following the pre-construction conference and continuing through substantial completion and until final completion. The Owner's Authorized Representative may require additional on-site 'tail-gate' meetings as necessary to resolve construction related issues and facilitate continued progress.
- C. Progress meetings shall be held at:
 

PSU, Office of Facilities  
202 University Services Building  
617 SW Montgomery
- D. The progress meeting minutes serve as the official communication between all parties involved in the Project. The Contractor shall:
  1. Prepare agendas.
  2. Record minutes and include decisions.
  3. Record attendance
  4. Distribute minutes to attendees within three (3) calendar days after meetings.
- E. Minimum agenda shall include:
  1. Review and approve minutes of previous meetings.
  2. Review work progress and work schedule since previous meeting.

3. Discuss field observations, problems, clarifications and information required.
4. Review delivery schedules. Identify problems that could impede planned progress.
5. Review proposed changes in construction or procedures.
6. Delivery and discussion of submittals.
7. Submittal of progress payment requests for review.
8. Other items as may be required.

### 3.11 REQUESTS FOR CLARIFICATIONS AND INFORMATION

- A. Throughout the course of work, the Contractor may require clarifications or additional information from the Architect or Owner's Authorized Representative. This information may include but not be limited to the following:
  1. Clarifications whether specific work is within the scope of an item of work and no Contract adjustment is anticipated.
  2. Clarifications or interpretations of information or directions provided in the Contract Documents, for which no Contract adjustment is anticipated.
  3. Clarifications or directions as a result of unforeseen conditions, which may or may not result in adjustments to the Contract Sum or days allowed for contract completion.
  4. Additional details or information needed for construction, which were not originally included in the contract documents, which may or may not result in adjustments to the Contract Sum or days allowed for contract completion.
- B. The contractor's field superintendent shall be the principle generator of requests for clarification and information (RFI's) as a result of field operations and conditions.
- C. Three copies of requests for clarifications and information (RFI) shall be typed and submitted in accordance with the communication process described in Section 01300.
- D. All RFI's shall be sequentially numbered and include the following information:
  1. Project item information as specified in Section 01300, Item 1.05.
  2. Reason for request, and clarification and information requested.
  3. Work impacted by request for clarification or information.
  4. Drawings or sketches as necessary.
  5. Contractors recommendations as appropriate.
  6. Signature and date by contractor's authorized representative.
- E. If the contractor anticipates that a change in the scope of work may be necessary in conjunction with a request for clarification or information, he may submit with the request a proposal to perform additional work as a Contract Change Order as specified herein. No changes in work shall commence without an approved RFI response, Construction Directive or Executed Contract Change Order.
- F. All RFI Responses will be by the Architect through and with the approval of the Owner's Authorized Representative.
- G. Response time to process RFI's shall be seven (7) calendar days from the date received by the Architect, to allow reasonable time for researching the question and preparing a response. If, due to unavoidable circumstances, information is needed immediately, coordinate with the Owner's Authorized Representative who will attempt to expedite a response by FAX or e-mail. When responses are expedited, an RFI must still be

submitted as a confirmation of the communication prior to submitting for progress payment for the related work.

- H. A log and copies of all RFI's shall be maintained in the jobsite office, for review or reference by the Contractor, Architect and Owner's Authorized Representative.

### 3.12 CONSTRUCTION DIRECTIVES

- A. Construction Directives may be initiated by the Owner's Authorized Representative, or the Architect on approval of the Owner's Authorized representative, and provides interpretations of the contract documents or orders minor changes in the work, which may require changes in the Contract Sum or Contract Time, which would be subsequently executed through a Construction Change Order. Interpretation of the Contract documents shall be in accordance with OUS General conditions for Public Improvement Contracts Section A.3, and as amended by the OUS Supplemental General Conditions. Construction Directives are not Construction Change Orders. If the Contractor believes the work described in a Construction Directive requires a change in Contract Sum or Contract Time, he shall submit a proposal to perform additional work as a Construction Change Order as specified herein. Do not proceed with Construction Order work until a proposal for Change Order work has been submitted and Contractor has been directed to proceed by the Owner's Authorized Representative. Proceeding without authorization waives the Contractor's claim for additional Contract Sum or Contract Time.
- B. Construction Directives shall be executed using the attached Construction Directive form.

### 3.13 CONSTRUCTION CHANGE ORDERS

- A. Contract Bid award is based on the Base Bid. Additional work may be authorized by amending the Contract based upon Unit Prices provided in the Bid Form, the Contractor's Schedule of Values, or other Contractor Proposals approved by the Owner's Authorized Representative, and in accordance with Section D of the OUS General Conditions for Public Improvement Contracts.
- B. A Construction Change Order is a written order issued after the execution of a contract, which authorizes and directs a change in scope of work and an adjustment in the Contract Sum, Contract Time or both. Change Orders will be processed using AIA Document 701, and is not complete until all signatures have been obtained and a signed copy is received by the Contractor.
- C. A Contract Change Order request can be initiated by the Owner's Authorized Representative through a proposal request to the Contractor, or by the Contractor through submittal of a proposal request in conjunction with a RFI response or Construction Directive.
- D. The Contractor's proposal for Contract Change Order Work shall include the following:
  - 1. Project item information as specified in Section 01305, Item 1.05.
  - 2. Reason for request
  - 3. Itemized statement of required materials and equipment, including adjustments to adjacent and dependent work.
  - 4. Itemized statement of required labor, including adjustments to adjacent and dependent work.
  - 5. Total Contract Sum adjustment required for the Change in Work.

6. Total Contract Time adjustment required for the Change in Work.
  7. Additional Documentation as required to support the request.
  8. Signature and date by contractor's authorized representative.
- E. Construction Change Order work shall be reviewed by the Architect and the Owner's Authorized Representative and executed in accordance with OUS General Conditions for Public Improvement Contracts Section D, and as amended herein.
- F. If a fair and reasonable Contract Change Order adjustment can not be agreed upon, the Owner's Authorized Representative may in writing direct the Contractor to proceed with the Change in Work on a 'Time and Materials' basis in accordance with OUS General Conditions for Public Improvement Contracts.

END OF SECTION

PORTLAND STATE UNIVERSITY  
OFFICE OF FACILITIES  
PROJECT INFORMATION

**Project Name: Campus Wide Loop –Steam & Chilled Water Improvements – Phase 2 BP-4**

**Project No:**

**Project Description:**

**Project Address:**

**Work Start Date:**

**Project Manager:**

**Phone:** (503) 725-

**FAX:** (503) 725-4329

**Project Site Construction Manager:**

**Phone:** (503) 725-

**Design Consultant:**

**Phone:**

**Address:**

**E-Mail :**

**FAX:**

**Bid Opening Date:**

**Contract Bid Price:**

**Contract Execution Date:**

**Pre-Const. Meeting:**

**Notice to Proceed Date:**

**Contract Calendar Days:**

**Final Contract Completion Date:**

**Liquidated Damages:** \$1,000 per D.

**Contractor Name:**

**Office Phone:**

**Project Manager:**

**Cell:**

**Pager:**

**Contractor Office Address:**

**E-Mail:**

**Office FAX:**

**On Site Construction Office Address:**

**Site Phone:**

**Site E-Mail:**

**Site FAX:**

**Site Superintendent:**

**Cell:**

**Pager:**

**Contractor's Emergency & Weekend Phone:**

**1.**

**2.**

**3.**



PORTLAND STATE UNIVERSITY  
OFFICE OF FACILITIES  
CONSTRUCTION PROJECT SAFETY FORM INSTRUCTIONS

The purpose of the Construction Project Safety Form is to allow contractors to plan the construction or remodeling project in such a way as to prevent injuries and protect the environment. **This form will need to be filled out by the Contractor and provided to the Owner's Authorized Representative at the preconstruction conference.**

**The information provided on the form will be reviewed at the preconstruction conference.**

All projects must be planned with safety consideration for people who will be in contact with the area; in particular, sight, hearing, or mobility impaired people who are not covered under OSHA regulations but are covered under general liability issues.

PSU requires that all contractors and subcontractors come to the job trained in all Occupational Safety and Health ACT (OSHA) Standards applicable to their work process. This information is outlined in the OR-OSHA document "Occupational Hazards Common to Construction & Remodeling Activities." This document can be obtained free of charge by contacting the OR-OSHA Resource Center at 1-800-922-2689 or on-line at [www.ORSHA.org](http://www.ORSHA.org).

All construction and remodeling activities regardless of size and/or scope must be fenced, barricaded, or otherwise protected (isolated) to restrict entrance and to ensure the safety of those in the general area. **All building materials and equipment need to be placed within the isolation enclosure.** Any open trenches outside the isolated space will need to be fenced or covered with approved cover (contact the Owner's Authorized Representative for specifics).

**REQUIRED PROJECT ISOLATION AND BARRICADING OPEN TRENCHES FOR OUTSIDE CONSTRUCTION SITES**

Construction projects that involve building a facility, any exterior remodel, any excavation, or demolition, at a minimum, will install the following perimeter isolation:

*A six foot chain-link fence, with controlled access points, extending in all directions around the excavation or building site such that no area of the construction is accessible to pedestrians or unauthorized personnel or vehicles. Note: At the University's option, other barricading plans may be accepted. These may apply to projects such as road resurfacing, parking lot striping, exterior building water proofing, etc.*

Indoor projects which will create dust (cutting sheetrock, sanding, sawing etc.) are subject to the following:

1. Areas where existing doors can provide isolation will be labeled "Construction Area Authorized Personnel Only."
2. All other areas will be isolated by a solid barrier. The minimum barrier allowed is 4 mil poly sheeting.

**Any excavation across or adjacent to sidewalks or pathways which must be left open overnight, must be identified with working, blinking, construction lights in addition to being covered.**

**The contractor will provide all trench covering and fencing material, PSU will not provide any materials.**

Portland State University  
OFFICE OF FACILITIES  
CONSTRUCTION PROJECT SAFETY FORM

Complete and deliver with the Project Information sheet to the Owner's Authorized Representative at the Pre-Construction Conference.

Meeting Date: \_\_\_\_\_ Time: \_\_\_\_\_ Location: \_\_\_\_\_

Project: \_\_\_\_\_ Job #: \_\_\_\_\_

Contractor: \_\_\_\_\_ Start: \_\_\_\_\_ Completion: \_\_\_\_\_

Contractor Foreman: \_\_\_\_\_

PSU Project Mgr: \_\_\_\_\_

Emergency Fire/Medical/Security #: 911      Non-Emergency Campus Safety (503) 725-4404

Confined Space to be accessed? Y or N Location: \_\_\_\_\_

If yes, review confined space program with PSU Project Manager

Welding or hot work to be done? Y or N If yes, describe extinguisher, and fire watch, plan:

\_\_\_\_\_

MSDS copies to be on the job site and copies available to PSU Project Manager.

Lead paint involved? Y or N Contact PSU Environmental Health & Safety Supervisor (503) 725-3738

Describe hazard mitigation plan: \_\_\_\_\_

\_\_\_\_\_

Asbestos involved? Y or N If yes, Contact PSU Environmental Health & Safety Supervisor (503) 725-3738

Hazard Waste Plan developed? Y or N Containers: \_\_\_\_\_

\_\_\_\_\_ Storage Loc: \_\_\_\_\_

\_\_\_\_\_

In the event of suspected hazardous materials or spill contact PSU Environmental Health & Safety Supervisor (503) 725-3738.

Describe hazmat spill plan: \_\_\_\_\_  
\_\_\_\_\_  
\_\_\_\_\_

Will there be any open trenches or holes? Y or N Describe plan to barricade: \_\_\_\_\_  
\_\_\_\_\_  
\_\_\_\_\_

Internal combustion engines? Y or N If yes, is CO monitoring required? Y N

Other air contaminates? Y or N If yes, describe: \_\_\_\_\_

Building air intake & return air locations: \_\_\_\_\_

**(No chemical compounds to be used near functioning intake or return air locations.)**

Material deliver or parking creating hazard? Y or N If yes, describe minimization plan: \_\_\_\_\_  
\_\_\_\_\_  
\_\_\_\_\_

**No vehicle is allowed to park on sidewalk entrances/exits to steam tunnel (metal hatch cover).**

Dust created? Y or N If yes, describe control plan: \_\_\_\_\_  
\_\_\_\_\_

Noise sources? List: \_\_\_\_\_

Describe noise control methods: \_\_\_\_\_

Crane to be used? Y or N If yes, describe plan: \_\_\_\_\_  
\_\_\_\_\_

(Loads will not be moved over or suspended above pedestrian occupied areas)

Exterior chute to be used? Y or N If yes describe plan: \_\_\_\_\_  
\_\_\_\_\_

Construction area to be fenced? Y or N Type & location: \_\_\_\_\_

\_\_\_\_\_

Fence to be locked? Y or N Job Trailer on site? Y or N To be locked? Y or N All contractor lock keys to Security Services dispatch and PSU Project Manager

Building exitways to be blocked or restricted at any time? Y or N If yes, describe ADA alternate routes and overall egress plan: \_\_\_\_\_

\_\_\_\_\_

Will project create interior hazards to building occupants? Y or N If yes, describe hazards and minimization plan: \_\_\_\_\_

\_\_\_\_\_

Lock changes planned? Y or N If yes, describe location and responsible party: \_\_\_\_\_

\_\_\_\_\_

\_\_\_\_\_

PORTLAND STATE UNIVERSITY  
OFFICE OF FACILITIES  
REQUEST FOR INFORMATION

Project: Campus Wide Loop – Phase 2, Steam & Chilled Water Improvements – BP4  
RFI No.: \_\_\_\_\_

Contractor: \_\_\_\_\_ Date submitted: \_\_\_\_\_

Subcontractor: \_\_\_\_\_ Date info req'd: \_\_\_\_\_

Supplier: \_\_\_\_\_

Provide all information required by Specification Division I Section 01040. Attach additional sheets as required.

---

---

Request:

Contractor \_\_\_\_\_ Date \_\_\_\_\_

Response:

Architect \_\_\_\_\_ Date \_\_\_\_\_

Acknowledgement by Owner's Rep. \_\_\_\_\_ Date \_\_\_\_\_

PORTLAND STATE UNIVERSITY  
OFFICE OF FACILITIES  
CONSTRUCTION DIRECTIVE

Project: Campus Wide Loop – Phase 2, Steam & Chilled Water Improvements – BP4  
Directive No.: \_\_\_\_\_

Contractor: \_\_\_\_\_ Date submitted: \_\_\_\_\_

Subcontractor: \_\_\_\_\_ Date info req'd: \_\_\_\_\_

Supplier: \_\_\_\_\_

You are hereby directed to execute promptly this Directive which interprets the Contract Documents or orders minor changes in the work. If you consider that a change in Contract Sum or Contract Time is required, submit an itemized change order proposal as required by Specification Division I Section 01040. If your proposal is in order, this Directive will be superseded by a Change Order.

---

---

Description:

Architect: \_\_\_\_\_ Date: \_\_\_\_\_

Owner's Authorized Rep: \_\_\_\_\_ Date: \_\_\_\_\_

## **SECTION 01045 CUTTING AND PATCHING**

### **PART 1 -GENERAL**

#### 1.01 DESCRIPTION

- A. Work of this Section includes administrative and procedural requirements for cutting and patching.

#### 1.02 RELATED WORK IN OTHER SECTIONS

- A. Additional information regarding cutting and patching requirements may be found in the follows:
  - 1. OUS General Conditions
  - 2. Other Sections of these specifications.
  - 3. Drawings and general provisions of the Contract, including General and Supplementary Conditions and other Division I Specification Sections, apply to this Section.

#### 1.03 QUALITY ASSURANCE

- A. The Contractor shall perform all cutting and patching in conformance with OUS General Conditions for Public Improvements Section F.3 and as specified herein.
- B. Requirements for Structural Work: Do not cut and patch structural elements in a manner that would change their load-carrying capacity or load-deflection ratio. The Owner's Authorized Representative shall pre-approve all field modifications.
- C. Operational Limitations: Do not cut and patch operating elements or related components in a manner that would result in reducing their capacity to perform as intended. Do not cut and patch operating elements or related components in a manner that would result in increased maintenance or decreased operation life or safety.
- D. Visual Requirements: Do not cut and patch construction exposed on the exterior or in occupied spaces in a manner that would, in the Architect's opinion, reduce the building's aesthetic qualities. Do not cut and patch construction in a manner that would result in visual evidence of cutting and patching. The contractor shall remove and replace construction cut and patched in a visually unsatisfactory manner at no expense to the owner.

### **PART 2 -PRODUCTS**

#### 2.1 GENERAL REQUIREMENTS:

- A. Use materials identical to existing materials. For exposed surfaces, use materials that visually match existing adjacent surfaces to the fullest extent possible if identical materials are unavailable or cannot be used. Use materials whose installed performance will equal or surpass that of existing materials.

## **PART 3 -EXECUTION**

### **3.1 INSPECTION:**

- A. Examine surfaces to be cut and patched and conditions under which cutting and patching is to be performed before cutting. If unsafe or unsatisfactory conditions are encountered, take corrective action before proceeding.

### **3.2 PREPARATION:**

- A. Temporary Support: Provide temporary support of work to be cut.
- B. Protection: Protect existing construction during cutting and patching to prevent damage. Provide protection from adverse weather conditions for portions of the Project that might be exposed during cutting and patching operations.
- C. Avoid interference with use of adjoining areas or interruption of free passage to adjoining areas.
- D. Avoid cutting existing pipe, conduit, or ductwork serving the building but scheduled to be removed or relocated until provisions have been made to bypass them.

### **3.3 PERFORMANCE**

- A. General: Employ skilled workmen to perform cutting and patching. Proceed with cutting and patching at the earliest feasible time and complete without delay.
- B. Cutting:
  - 1. Cut existing construction to provide for installation of other components or performance of other construction activities and the subsequent fitting and patching required to restore surfaces to their original condition.
  - 2. Cut existing construction using methods least likely to damage elements retained or adjoining construction.
  - 3. In general, where cutting, use hand or small power tools designed for sawing or grinding, not hammering and chopping. Cut holes and slots as small as possible, neatly to size required, and with minimum disturbance of adjacent surfaces. Temporarily cover openings when not in use.
  - 4. To avoid marring existing finished surfaces, cut or drill from the exposed or finished side into concealed surfaces.
  - 5. Cut through concrete and masonry using a cutting machine, such as a Carborundum saw or a diamond-core drill.
  - 6. Comply with requirements of applicable Division 2 Sections where cutting and patching requires excavating and backfilling.
  - 7. Where services are required to be removed, relocated, or abandoned, by-pass utility services, such as pipe or conduit, before cutting. Cut-off pipe or conduit in walls or partitions to be removed. Cap, valve, or plug and seal the remaining portion of pipe or conduit to prevent entrance of moisture or other foreign matter.
- C. Patching:
  - 1. Patch with durable seams that are as invisible as possible. Comply with specified tolerances.



2. Where feasible, inspect and test patched areas to demonstrate integrity of the installation.
3. Restore exposed finishes of patched areas and extend finish restoration into retained adjoining construction in a manner that will eliminate evidence of patching and refinishing.
4. Where removing walls or partitions extends one finished area into another, patch and repair floor and wall surfaces in the new space. Provide an even surface of uniform color and appearance.
5. Where patching occurs in a smooth painted surface, extend final paint coat over entire unbroken surface containing the patch after the area has received primer and second coat.
6. Patch, repair, or rehang existing ceilings as necessary to provide an even-plane surface of uniform appearance.

D. Cleaning:

1. Clean areas and spaces where cutting and patching are performed. Completely remove paint, mortar, oils, putty, and similar items. Thoroughly clean piping, conduit, and similar features before applying paint or other finishing materials. Restore damaged pipe covering to its original condition.

END OF SECTION

## SECTION 01300 SUBMITTALS

### PART 1 -GENERAL

#### 1.01 DESCRIPTION:

A. The requirements specified in this Section relate to Submittal materials, Requests for Information and Requests for Clarification by all Contractors, Sub-contractors and Suppliers performing Work under these Contract Documents and includes:

1. Submittal Procedures
2. Submittals Schedule
3. Proposed Products List
4. Shop Drawings
5. Product Data
6. Samples
7. Manufacturer's Instructions
8. Manufacturer's Operations & Maintenance Manuals
9. Manufacturer's Certificates

#### 1.02 RELATED WORK IN OTHER SECTIONS:

A. Additional submittal requirements may be provided as follows:

1. Instructions to Bidders
2. OUS General Conditions
3. Supplemental General Conditions
4. Other Sections of these specifications.

1.03 All Submittals, Shop Drawings, Product Data and Samples shall be in accordance with OUS General Conditions for Public Improvement Contracts Section B. and as specified herein.

1.04 Transmit six (6) copies of each submittal with sequentially numbered forms. Provide two (2) additional copies when submittal involves mechanical or electrical review. Re-submittals shall have original number and alphabetic prefix.

1.05 Identify Project, Contractor, Subcontractor and supplier; pertinent drawing sheet and detail number(s), and specification numbers, as appropriate.

1.06 Review of the submittals by the Architect and Owner's Authorized Representative shall not relieve the Contractor of its obligations as specified in OUS General Conditions for Public Improvement Contracts Section B.18.

1.07 The General Contractor shall sign certifying that review, verification of products required, field dimensions, adjacent construction work and coordination of information, is in accordance with the work of the Contract Documents.

1.08 Provide space for review approval by Architect and the Owner's Authorized Representative, as specified herein.

1.09 Schedule submittals to expedite Project; deliver to Architect and Owner's Authorized Representative as directed herein and coordinate submission of related items.

**PART 2 - PRODUCTS – NOT APPLICABLE**

**PART 3 - EXECUTION**

3.01 Seventy-two (72) hours prior to the pre-construction conference and in all cases prior to the commencement of work, the Contractor shall submit the following to the Owner’s Authorized Representative:

- A. Certificate of Insurance as required.
- B. Signed Public Improvement Agreement.
- C. Five (5) original copies of Performance & Payment Bonds.
- D. Schedule of Values.
- E. Project Construction Schedule.
- F. Submittal List and Schedule of Submittals, identifying long lead items.
- G. Contractor Emergency Contact Information.

3.02 Prepare Schedule of Submittals in chronological order by date of required submittal approval. Indicate the following:

- A. Category of submittal.
- B. Name of sub-contractor or supplier.
- C. Generic Description of Work covered.
- D. Related Specification Section Number.
- E. Activity or event number on the project construction schedule.
- F. Proposed submittal date for first submittal.
- G. Date material required for installation.
- H. Re-submittal dates and final release or approval by Architect and Owner’s Authorized Representative.

3.03 The general Submittal Review Procedure is illustrated in the following diagram.

- A. Sub-contractor and/or Supplier submits to General Contractor for review/ approval
- B. If approved, General Contractor submits to Architect for review/ approval.
- C. Architect submits to Design Team Consultants for review/ approval.
- D. If approved, Architect Submits to PSU Project Manager for review/ approval.

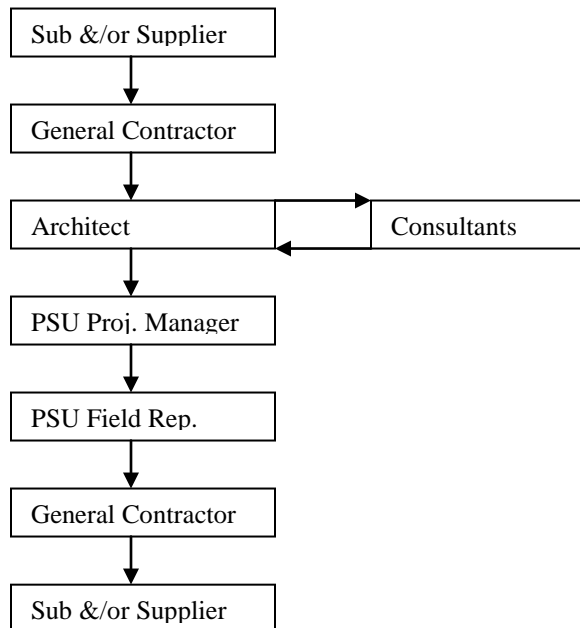

- E. If approved, PSU  
Project Manager submits  
To PSU Field Representative  
for approval and delivery to  
General Contractor's Project  
Representative.
- 3.04 Allow fourteen (14) calendar days for submittal review by Architect and Owner's Authorized Representative. Allow (3) additional calendar days for mechanical and electrical reviews. The General Contractor shall be responsible for timely the submittal of materials approvals in order to satisfy required delivery dates and maintain the construction schedule.
- 3.05 ACTION BY ARCHITECT AND OWNER'S REPRESENTATIVE
- A. Except for submittals for the record or information, where action and return is required, the Architect will review each submittal, mark to indicate action taken, and return promptly through and with approval of the Owner's Authorized Representative. All unacceptable or rejected submittals shall be immediately corrected and resubmitted for review.
    - 1. Compliance with specified characteristics is the Contractor's responsibility.
  - B. Action Stamp: The Architect will stamp each submittal with a uniform action stamp. The Architect will mark the stamp appropriately to indicate the action taken, as follows:
    - 1. Final Unrestricted Release: When the Architect marks a submittal "No Exceptions Taken," the Work covered by the submittal may proceed provided it complies with requirements of the Contract Documents.
    - 2. Final-But-Restricted Release: When the Architect marks a submittal "Make Corrections Noted," the Work covered by the submittal may proceed provided it complies with notations or corrections on the submittal and requirements of the Contract Documents.
    - 3. Returned for Resubmittal: When the Architect marks a submittal "Revise and Resubmit," do not proceed with Work covered by the submittal, including purchasing, fabrication, delivery, or other activity. Revise or prepare a new submittal according to the notations; resubmit without delay. Repeat if necessary to obtain different action mark.
    - 4. Unsolicited Submittals: The Architect will return unsolicited submittals to the sender without action.
- 3.06 The Owner's Representative may request additional information during the course of the project to monitor material and equipment deliveries as well as coordinate work and materials by others. The General Contractor may be required to submit and periodically update a Material Delivery Summary indicating material order dates, purchase order numbers, expected delivery dates and actual delivery dates.
- 3.07 SHOP DRAWINGS
- A. Submit newly prepared information drawn accurately to scale. Highlight, encircle, or otherwise indicate deviations from the Contract Documents. Do not reproduce Contract Documents as the basis of Shop Drawings.
  - B. Shop Drawings include fabrication and installation Drawings, setting diagrams, schedules, patterns, templates and similar Drawings. Include the following information:

1. Dimensions.
  2. Identification of products and materials included by sheet and detail number.
  3. Compliance with specified standards.
  4. Notation of coordination requirements.
  5. Notation of dimensions established by field measurement.
  6. Sheet Size: Except for templates, patterns and similar full-size Drawings, submit Shop Drawings on sheets at least **8-1/2 by 11 inches** but no larger than **30 by 42 inches**.
  7. Do not use Shop Drawings without an appropriate final stamp indicating action taken.
- C. Subsequent to Substantial Completion and prior to Final Pay Request, Submit five (5) copies of As Built documentation of all shop drawings to the Architect for inclusion in Project Record Documents. See OUS General Conditions for Public Improvement Contracts Section K and Division 1 Section 01780 for Project Closeout requirements.

### 3.08 PRODUCT DATA

- A. Collect Product Data into a single submittal for each element of construction or system. Product Data includes printed information, such as manufacturer's installation instructions, catalog cuts, standard color charts, roughing-in diagrams and templates, standard wiring diagrams, and performance curves.
1. Mark each copy to show applicable choices and options. Where printed Product Data includes information on several products that are not required, mark copies to indicate the applicable information. Include the following information:
    - a. Manufacturer's printed recommendations.
    - b. Compliance with trade association standards.
    - c. Compliance with recognized testing agency standards.
    - d. Notation of dimensions verified by field measurement.
    - e. Notation of coordination requirements.
  2. Do not submit Product Data until compliance with requirements of the Contract Documents has been confirmed.
  3. Submittals: Submit 6 copies of each required submittal; submit 2 additional copies where review is required by Architect's consultants. Up to four copies will be retained by Architect and Owner, plus copies by Architect's consultant, the remaining copies will returned marked with action taken and corrections or modifications required.
  4. Distribution: Furnish copies of final submittal to installers, subcontractors, suppliers, manufacturers, fabricators, and others required for performance of construction activities.
    - a. Do not proceed with installation until a copy of Product Data is in the Installer's possession.
    - b. Do not permit use of unmarked copies of Product Data in connection with construction.

### 3.09 SAMPLES

- A. Submit full-size, fully fabricated Samples cured and finished as specified and physically identical with the material or product proposed. Samples include partial sections of manufactured or fabricated components, cuts or containers of materials, color range sets, and swatches showing color, texture, and pattern.
  - 1. Mount or display Samples in the manner to facilitate review of qualities indicated. Prepare Samples to match the Architect's sample. Include the following:
    - a. Specification Section number and reference.
    - b. Product name or name of the manufacturer.
    - c. Compliance with recognized standards.
  - 2. Submit Samples for review of size, kind, color, pattern, and texture. Submit Samples for a final check of these characteristics with other elements and a comparison of these characteristics between the final submittal and the actual component as delivered and installed.
    - a. Where variation in color, pattern, texture, or other characteristic is inherent in the material or product represented, submit at least 3 multiple units that show approximate limits of the variations.
    - b. Samples not incorporated into the Work, or otherwise designated as the Owner's property, are the property of the Contractor and shall be removed from the site prior to Substantial Completion.
  - 3. Submittals: Except for Samples illustrating assembly details, workmanship, fabrication techniques, connections, operation, and similar characteristics, submit three sets. The Architect will return two sets marked with the action taken.
  - 4. Maintain sets of Samples, as returned, at the Project Site, for quality comparisons throughout the course of construction.
    - a. Unless noncompliance with Contract Document provisions is observed, the submittal may serve as the final submittal.
    - b. Sample sets may be used to obtain final acceptance of the construction associated with each set.
    - c. Distribution of Samples: Prepare and distribute additional sets to subcontractors, manufacturers, fabricators, suppliers, installers, and others as required for performance of the Work.

### 3.10 QUALITY ASSURANCE SUBMITTALS

- A. Submit quality-control submittals, including design data, certifications, manufacturer's instructions, manufacturer's field reports, and other quality-control submittals as required under other Sections of the Specifications.
- B. Certifications: Where other Sections of the Specifications require certification that a product, material, or installation complies with specified requirements, submit a notarized certification from the manufacturer certifying compliance with specified requirements.
  - 1. Signature: Certification shall be signed by an officer of the manufacturer or other individual authorized to sign documents on behalf of the company.

- C. Inspection and Test Reports: Requirements for submittal of inspection and test reports from independent testing agencies are specified in Division 1 Section "Quality Control."

### 3.11 MANUFACTURER'S INSTRUCTIONS

- A. When specified in individual Specification Sections, submit manufacturer's printed instructions for delivery, storage, assembly, start-up, testing, adjusting and finishing.
- B. Submit any conflicts between the manufacturer's instructions and the Contract Documents for clarification by the Architect and Owner's Authorized Representative.

### 3.12 MANUFACTURER'S CERTIFICATE

- A. When specified in individual Specification Sections, submit manufacturer's certificate for review, in quantities specified.
- B. Indicate material or product conforms to or exceeds specific requirements. Submit supporting reference data, affidavits, and certificates as appropriate.
- C. Certificates may be recent or previous test results on materials or products, but must be acceptable to the Architect and the Owner's Authorized Representative.

END OF SECTION

## SECTION 01400 QUALITY REQUIREMENTS

### PART 1 -GENERAL

#### 1.01 DESCRIPTION

- A. The requirements specified in this Section relate to general quality control of the Project and supplement the quality control requirements specified in the OUS General Conditions for Public Improvement Contracts and other Sections of these Specifications. The requirements of this Section relate to all work performed by all Contractors and Sub-contractors performing work under these Contract Documents and include:
1. References and standards.
  2. Quality assurance submittals.
  3. Mock-ups.
  4. Control of installation.
  5. Tolerances.
  6. Testing and inspection services.
  7. Manufacturers' field services.

#### 1.02 RELATED SECTIONS

- A. Additional requirements related to Quality Requirements may be provided as follows:
1. OUS General Conditions
  2. Other Sections of the specifications.

#### 1.03 REFERENCES

- A. ASTM C 1021 -Standard Practice for Laboratories Engaged in Testing of Building Sealants; 1997.
- B. ASTM C 1077 -Standard Practice for Laboratories Testing Concrete and Concrete Aggregates for Use in Construction and Criteria for Laboratory Evaluation; 2000.
- C. ASTM C 1093 -Standard Practice for Accreditation of Testing Agencies for Unit Masonry; 1995.
- D. ASTM D 3740 -Standard Practice for Minimum Requirements for Agencies Engaged in the Testing and/or Inspection of Soil and Rock as Used in Engineering Design and Construction; 1999c.
- E. ASTM E 329 -Standard Specification for Agencies Engaged in the Testing and/or Inspection of Materials Used in Construction; 2000b.
- F. ASTM E 543 – Standard Practice for Agencies Performing Nondestructive Testing; 1999.
- G. ASTM E 548 – Standard Guide for General Criteria used for Evaluating Laboratory Competence; 1994.

#### 1.04 SUBMITTALS

- A. Testing Agency Qualifications:



1. Prior to start of Work, submit agency name, address, and telephone number, and names of full time registered Engineer and responsible officer.
  2. Submit copy of report of laboratory facilities inspection made by Materials Reference Laboratory of National Bureau of Standards during most recent inspection, with memorandum of remedies of any deficiencies reported by the inspection.
- B. Design Data: Submit for Architect's knowledge as contract administrator or for the Owner, for information for the limited purpose of assessing conformance with information given and the design concept expressed in the contract documents.
- C. Test Reports: After each test/inspection, promptly submit two copies of the report to the Contractor and additional copies to the Architect and Owner's Authorized Representative for processing through the procedure specified in Section 01305. All test reports shall include the following information:
1. Date issued.
  2. Project title and number.
  3. Name of inspector.
  4. Date and time of sampling or inspection.
  5. Identification of product and specifications section.
  6. Location In the Project.
  7. Type of test/inspection.
  8. Date of test/inspection.
  9. Results of test/inspection.
  10. Conformance with Contract Documents.
  11. When requested by Architect, provide interpretation of results.
- D. Certificates: When specified in individual specification sections, submit certification by the manufacturer and Contractor or installation/application subcontractor to Architect and Owner's Authorized Representative, in accordance with the procedure specified in Section 01305. All certificates shall include the following information:
1. Indicate material or product conforms to or exceeds specified requirements. Submit supporting reference data, affidavits, and certifications as appropriate.
  2. Certificates may be recent or previous test results on material or product, but must be acceptable to the Architect and Owner.
- E. Manufacturer's Instructions: When specified in individual specification sections, submit printed instructions for delivery, storage, assembly, installation, start-up, adjusting, and finishing, for the Owner's information. Indicate special procedures, perimeter conditions requiring special attention, and special environmental criteria required for application or installation.
- F. Manufacturer's Field Reports: Submit reports for review by Architect and Owner's Authorized Representative.
1. Submit report in duplicate within 30 days of observation to Architect for information.
  2. Submit for information for the limited purpose of assessing conformance with information given and the design concept expressed in the contract documents.

- G. Erection Drawings: Submit drawings for review and approval by Architect and Owner's Authorized Representative, in accordance with the procedure specified in Section 01305.
  - 1. Submit information for the limited purpose of assessing quality control, and conformance with the design concept and contract documents.

#### 1.05 REFERENCES AND STANDARDS

- A. For products and workmanship specified by reference to a document or documents not included in the Project Manual, also referred to as reference standards, comply with requirements of the standard, except when more rigid requirements are specified or are required by applicable codes.
- B. Conform to reference standard of date of issue current on date of Contract Documents, except where a specific date is established by applicable code.
- C. Obtain copies of standards where required by product specification sections.
- D. Maintain copy at project site during submittals, planning, and progress of the specific work, until Substantial Completion.
- E. Should specified reference standards conflict with Contract Documents, request clarification from Architect before proceeding.

#### 1.06 TESTING AND INSPECTION AGENCIES

- A. Unless otherwise directed in writing by the Owner's Authorized Representative, the Contractor shall make arrangements for all required testing and inspections in accordance with OUS General Conditions for Public Improvement Contracts Section B.7.
- B. Employment of agency in no way relieves Contractor of obligation to perform Work in accordance with requirements of Contract Documents.
- C. Employed Agency shall comply with the following criteria:
  - 1. Testing agency: Comply with requirements of ASTM E 329, ASTM E 548, ASTM E 543, .ASTM C 1021, ASTM C 1077, and ASTM C 1093.
  - 2. Inspection agency: Comply with requirements of ASTM 03740, ASTM E329, and ASTM E548.
  - 3. Laboratory: Authorized to operate in State in which Project is located.
  - 4. Laboratory Staff: Maintain a full time registered Engineer on staff to review services.
  - 5. Testing Equipment: Calibrated at reasonable intervals with devices of an accuracy traceable to either National Bureau of Standards or accepted values of natural physical constants.

## **PART 2- PRODUCTS**

NOT USED

## **PART 3- EXECUTION**

### **3.01 CONTROL OF INSTALLATION**

- A. Monitor quality control over suppliers, manufacturers, products, services, site conditions, and workmanship, to produce Work of specified quality.
- B. Comply with manufacturers' instructions, including each step in sequence.
- C. Should manufacturers' instructions conflict with Contract Documents, request clarification from Architect before proceeding.
- D. Comply with specified standards as minimum quality for the Work except where more stringent tolerances, codes, or specified requirements indicate higher standards or more precise workmanship.
- E. Have Work performed by persons qualified to produce required and specified quality.
- F. Verify that field measurements are as indicated on shop drawings or as instructed by the manufacturer.
- G. Secure products in place with positive anchorage devices designed and sized to withstand stresses, vibration, physical distortion, and disfigurement.

### **3.02 MOCK-UPS**

- A. When required by other Sections of these specifications or the Architect provide mock-ups for review of conformance with quality, performance and design intent.
- B. Review of mock-ups will be performed under provisions identified in this section and identified in the respective product specification sections.
- C. Assemble and erect specified items with specified attachment and anchorage devices, flashings, seals, and finishes.
- D. Accepted mock-ups shall be a comparison standard for the remaining Work.
- E. Where mock-up has been accepted by Architect and is specified in product specification sections to be removed, remove mock-up and clear area when directed to do so.

### **3.03 TOLERANCES**

- A. Monitor fabrication and installation tolerance control of products to produce acceptable Work. Do not permit tolerances to accumulate.
- B. Comply with manufacturers' tolerances. Should manufacturers' tolerances conflict with Contract Documents, request clarification from Architect before proceeding.
- C. Adjust products to appropriate dimensions; position before securing products in place.

### **3.04 TESTING AND INSPECTION**

- A. See individual specification sections for testing required.

B. Testing Agency Duties:

1. Test samples of mixes submitted by Contractor.
2. Provide qualified personnel at site. Cooperate with Architect and Contractor in performance of services.
3. Perform specified sampling and testing of products in accordance with specified standards.
4. Ascertain compliance of materials and mixes with requirements of Contract Documents.
5. Promptly notify Architect and Contractor of observed irregularities or non-conformance of Work or products.
6. Perform additional tests and inspections required by Architect or Owner's Authorized Representative.
7. Submit reports of all tests/inspections specified.

C. Limits on Testing/Inspection Agency Authority:

1. Agency may not release, revoke, alter, or enlarge on requirements of the Contract Documents.
2. Agency may not approve or accept any portion of the Work.
3. Agency may not assume any duties of Contractor.
4. Agency has no authority to stop the Work.

D. Contractor Responsibilities:

1. Deliver to agency at designated location, adequate samples of materials proposed to be used which require testing, along with proposed mix designs.
2. Cooperate with laboratory personnel, and provide access to the Work and to manufacturers' facilities.
3. Provide incidental labor and facilities:
4. To provide access to Work to be tested/inspected.
5. To obtain and handle samples at the site or at source of Products to be tested/inspected.
6. To facilitate tests/inspections.
7. To provide storage and curing of test samples.
8. Notify Architect and laboratory 24 hours prior to expected time for operations requiring testing/inspection services.
9. Employ services of an independent qualified testing laboratory and pay for additional samples, tests, and inspections required by Contractor beyond specified requirements.
10. Arrange with Owner's agency and pay for additional samples, tests, and inspections required by Contractor beyond specified requirements.

E. Re-testing required because of non-conformance to specified requirements shall be performed by the same agency on instructions by Architect. Payment for re-testing will be charged to the Contractor by deducting testing charges from the Contract Price.

### 3.05 MANUFACTURERS' FIELD SERVICES

A. When specified in individual specification sections, require material or product suppliers or manufacturers to provide qualified staff personnel to observe site conditions, conditions of surfaces and installation, quality of workmanship, as applicable, and to initiate instructions when necessary.

- B. Submit qualifications of observer to Architect and Owner's Authorized Representative 30 days in advance of required observations.
  - 1. Observer subject to approval of Architect.
  - 2. Observer subject to approval of Owner.
- C. Report observations and site decisions or instructions given to applicators or installers that are supplemental or contrary to manufacturers' written instructions.

3.06 DEFECT ASSESSMENT

- A. Immediately replace Work or portions of the Work not conforming to the Contract Documents at no additional cost to the Owner.

END OF SECTION

**SECTION 01410**  
**TESTING LABORATORY SERVICES**

**PART 1 GENERAL**

1.1 SUMMARY

A. Section Includes

1. Coordinate sampling and testing with the Owner's selected testing laboratory and all others responsible for testing and inspecting the work. Provide other testing and inspecting as specified to be furnished by the contractor in this section and/or elsewhere in these specifications.

B. Related Sections

1. Section 02315 - Earthwork
2. Section 02316 - Trenching, Backfilling and Compaction

1.2 REFERENCES

- A. Not used in this section.

1.3 DEFINITIONS

- A. Not used in this section.

1.4 SUBMITTALS

- A. Not used in this section.

1.5 QUALITY ASSURANCE

- A. Qualifications of Testing Laboratory: The testing laboratory will be qualified to the Owner's approval.
- B. Codes and Standards: Testing, when required, will be in accordance with pertinent codes and regulations.

1.6 DELIVERY, STORAGE AND HANDLING

- A. Promptly process and distribute required copies of test reports and related instructions to ensure the least possible delay in progress of the work.
- B. Completion of Test Results: The results of the laboratory and/or field control tests shall be the principal basis upon which the satisfactory completion of the work shall be judged. Upon completion of placement of materials, the results of the field and laboratory tests and other data regarding the quality of the work will be embodied in a written report to the engineers by the testing laboratory, including conclusions as to the compliance of completed work with the specifications.

- C. If the results of testing show that materials which are below the requirements called for by these specifications, that portion of the work will be subject to condemnation. Any work so condemned shall be removed and replaced as directed at the Contractor's expense, including A/E's extra supervision costs.

#### 1.7 SCHEDULING AND SEQUENCING

- A. Not used in this section.

### **PART 2 PRODUCTS**

#### 2.1 PAYMENT FOR TESTING

- A. Initial Services: The Owner shall pay for initial testing services requested by the owner. When initial tests indicate noncompliance with the contract documents, the cost of initial tests associated with the noncompliance will be deducted by the owner from the contract sum.
- B. Retesting: When initial tests indicate noncompliance with the contract documents, all subsequent retesting occasioned by the noncompliance shall be performed by the same testing agency, and the costs thereof will be born by the contractor at no additional cost to the Owner.

#### 2.2 CODE COMPLIANCE TESTING

- A. Inspection and tests required by codes or ordinances, or by a plan approval authority, and which are made by a legally constituted authority, shall be the responsibility of and shall be paid for by the contractor, unless otherwise provided in the contract sum.

#### 2.3 CONTRACTOR'S CONVENIENCE TESTING

- A. Inspection and testing performed exclusively for the Contractor's convenience shall be the sole responsibility of the Contractor.

#### 2.4 INSPECTION BY OWNER'S PERSONNEL

- A. From time to time, personnel in the employ of the Owner may inspect the work where the work is in progress, but shall have no authority to direct the Contractor or request changes in the work except through the Owner's designated representative.

### **PART 3 EXECUTION**

#### 3.1 COOPERATION WITH TESTING LABORATORY

- A. Representatives of the testing laboratory shall have access to the work at all times. Provide facilities for such access in order that the laboratory may properly perform its function.

### 3.2 TAKING SPECIMENS

- A. Specimens and samples for testing, unless otherwise provided in the contract documents, will be taken by the testing personnel. Sampling equipment and personnel will be provided by the testing laboratory. Deliveries of specimens and samples to the testing laboratory will be performed by the testing laboratory.

### 3.3 SCHEDULES FOR TESTING

- A. Establishing the Schedule: By advance discussion with the testing laboratory selected by the Owner, determine the time required for the laboratory to perform its tests and to issue each of its findings.
- B. Revising the Schedule: When changes of construction schedule are necessary during construction, coordinate such changes of schedule with the testing laboratory as required.

### 3.4 ALTERNATIVE INSPECTION PROCEDURE

- A. The owner shall have the right to require alternative inspection procedures other than as specified when in the owner's judgment other inspections are required to demonstrate the compliance with the contract requirements. Costs of such alternative inspections will be borne by the Contractor.

END OF SECTION



**SECTION 01500**  
**TEMPORARY FACILITIES AND CONTROLS**

**PART 1 -GENERAL**

1.01 DESCRIPTION:

- A. The requirements specified in this Section relate to Temporary Facilities, Controls, Utilities and procedures required by all Sub-contractors through the General Contractor performing work under these Contract Documents and includes:
1. General Requirements for Temporary Facilities and Controls.
  2. Temporary Utilities.
  3. Temporary Electricity.
  4. Temporary Lighting.
  5. Temporary Heat.
  6. Temporary Ventilation.
  7. Temporary Telephone and Fax.
  8. Temporary Water Service.
  9. Temporary Sanitary Facilities.
  10. Temporary Fire Protection and Detection.
  11. Temporary Construction.
  12. Temporary Controls.
  13. Tree and Plant Protection.
  14. Security.
  15. Traffic Regulation and Parking.
  16. Project Identification.
  17. Field Office.
  18. Progress Cleaning
  19. Removal of Utilities, Facilities and Controls

1.02 RELATED WORK IN OTHER SECTIONS:

- A. Additional requirements related Temporary Facilities and Controls may be provided as follows:
1. OUS General Conditions
  2. Supplemental General Conditions
  3. Other Sections of these specifications.

1.03 GENERAL TEMPORARY FACILITIES AND CONTROL REQUIREMENTS

- A. This section specifies requirements for temporary services and facilities, including such items as temporary utility services, temporary construction and support facilities, temporary controls, traffic regulations, project security and protection.
- B. Cost or usage charges for temporary services or facilities are NOT chargeable to Owner, and will NOT be considered as basis for claim for change orders.
- C. Temporary utility services required for use at the Project Site include but are not limited to the following:
1. Water service and distribution.
  2. Temporary electric power and lighting.

3. Telephone, Fax and e-mail service.
- D. Temporary construction and support facilities required for Project include but are not limited to the following:
1. Temporary heat.
  2. Temporary ventilation.
  3. Sanitary facilities.
  4. Waste disposal service.
  5. Construction aids and miscellaneous general services and facilities.
  6. Temporary enclosures.
  7. Project identification, bulletin boards and signs.
  8. Field office.
  9. Parking
- E. Security and protection facilities and services required for Project include but are not limited to the following:
1. Temporary fire protection.
  2. Barricades, warning signs and lights.
  3. Environmental protection.
- F. Comply with requirements of local laws and regulations as well as Owner's requirements governing construction, and local industry standards, in installation and maintenance of temporary services and facilities, including but not limited to the following:
1. Building codes, including local requirements for permits, testing and inspection.
  2. Health and safety regulations.
  3. Utility company regulations and recommendations for temporary services.
  4. Police and Fire Department rules and recommendations.
  5. Environmental Protection Agency regulations and requirements.
  6. Hazardous Materials Safety Regulations.
- G. Comply with requirements of NFPA Code 241, "Standards for Safeguarding Building Construction and Demolition Operations" and ANSI -A 10 Series standards for "safety Requirements for Construction and Demolition" and AGC/ASA/ASC Joint Guideline #5, "Temporary Job Utility and Services". Refer to "Guidelines for Bid Conditions for Temporary Job Utilities and Services" as prepared jointly by AGC and ASC for industry recommendations
- H. Inspect and test each service before placing temporary utilities in use. Arrange for required inspections and tests by governing authorities, and obtain required certifications and permits for use.
- I. During progress of Work, submit copies of reports and permits required by governing authorities, or necessary for installation and efficient operation of temporary services and facilities.
- J. Provide each temporary service and facility ready for use at each location when service or facility is first needed to avoid delay in performance of Work. Maintain or expand as required and modify temporary services and facilities as needed throughout progress of Work. Do not remove until services or facilities are no longer needed, or are replaced by authorized use of completed permanent facilities.

- K. Operate temporary services and facilities in safe and efficient manner. Do not overload temporary services or facilities, and do not permit them to interfere with progress of Work. Should services of independent engineer be required to survey existing or temporary utilities, it shall be at no cost to Owner. Do not allow unsanitary conditions, public nuisances or hazardous conditions to develop or persist at the Site.
- L. Do not permit disruption of existing services, freezing of pipes, flooding or contamination of water sources.
- M. Maintain temporary facilities in such manner as to prevent discomfort to users. Take necessary fire protection measures. Maintain temporary support facilities in sanitary manner so as to avoid health problems and other deleterious effects.
- N. Maintain Site security and protection measures in safe, lawful and publicly acceptable manner. Take necessary measures to prevent site erosion, as applicable. At not time is Site to be without protective fence enclosure(s), as required to protect general public.

#### 1.04 TEMPORARY UTILITIES

- A. Coordinate with the Owner's Authorized Representative and make connections to existing services to provide temporary services to the Project. Connections to the service shall be the responsibility of the Contractor.
- B. Coordinate with the Owner's Authorized Representative for acceptable time for service interruptions, where necessary to make connections for temporary services.
- C. Do not interrupt any utility service. Seventy-two (72) hours prior request and approval from the Owner's Authorized Representative is required to enable the Owner to shut down any utility required for the work. Contractor's employees shall **not** shut down utilities.

#### 1.05 TEMPORARY WATER SERVICE

- A. Provide temporary water service and distribution piping of sizes and pressures adequate for construction purposes throughout the construction period and until permanent service is in use, including but not limited to following uses:
  - 1. Construction processes.
  - 2. Fire protection, as appropriate.
  - 3. Drinking water.
  - 4. Cleaning.
- B. Where water use is authorized by Owner's Authorized Representative, connect to Owner's metered source, usage will be paid by Owner. Contractor shall exercise water conservation measures, provide hoses with threaded connection and provide temporary pipe insulation to prevent freezing. Owner's Authorized Representative reserves the right to require the Contract to furnish and install a temporary flow meter during construction and pay for water use, if contractor does not exercise satisfactory water conservation measures.

## 1.06 TEMPORARY ELECTRICITY

- A. Provide weather proof, grounded temporary electric power service and distribution system of sufficient size, capacity and power characteristics to accommodate performance of Work during construction period.
- B. Install service and grounding in compliance with National Electric Code (NFPA 70). Include necessary meters, transformers, overload protected disconnect and main distribution switch gear.
- C. Provide metal conduit, tubing or armored cable for protection of temporary power wiring where exposed to possible damage during construction operations.
- D. Temporary service electrical wiring will be limited to 110-120 volt, 20-amp rating, and wiring of lighting circuits may be non-metallic sheathed cable in areas where located overhead and exposed for surveillance, where permitted by code. Do not wire temporary lighting with plain, exposed (insulated) electrical conductors. Provide metal enclosures or boxes for wiring devices.
- E. For power hand tools and task lighting, provide temporary 4-gang outlets at each floor level, spaced so that 100-foot extension cord can reach each area of Work. Provide separate 110 120 volt, 20 amp circuit for each 4-gang outlet (4 outlets per circuit).

## 1.07 TEMPORARY LIGHTING

- A. Wherever overhead floor or roof deck has been completed, install temporary lighting adequate to provide sufficient illumination for safe Work and traffic conditions in every area of Work. Take precautions to limit glare or direct illumination into areas occupied after dark.
- B. Provide and maintain lighting for construction operations to achieve minimum lighting level of 2 watt/sq. ft.
- C. Provide and maintain 1 watt/sq. ft. lighting to staging and storage areas during periods of non-construction after dark for security purposes.
- D. Provide and maintain 0.25 watt/sq. ft. lighting to interior work areas during periods of non-construction after dark for security purposes.
- E. Provide branch wiring from power source to distribution boxes with lighting conductors, pigtails, and lamps as required.
- F. Maintain lighting and provide routine repairs.

## 1.08 TEMPORARY TELEPHONE, FAX AND E-MAIL

- A. The Owner will provide connection line(s) for temporary telephone, facsimile (FAX) machine and electronic mail service to the job site field office location. Telephone service will be local access limited. Coordinate location and setup with the Owner's Authorized Representative.
- B. The Contractor shall provide temporary on site telephone equipment, facsimile (Fax) machine and electronic mail access system on dedicated lines at field office. See Section 01300, Project Administration for off site emergency contact requirements.

- C. Maintain temporary telephone, facsimile and e-mail service from start of Work through Final Completion.

#### 1.09 TEMPORARY HEAT

- A. Provide and pay for heat devices as required to maintain specified conditions for construction operations.

#### 1.10 TEMPORARY VENTILATION

- A. Ventilate enclosed areas to assist cure of materials, to dissipate humidity, and to prevent accumulation of dust, fumes, vapors, or gases. See Section 01734, Indoor Air Quality for addition temporary ventilation requirements.

#### 1.11 TEMPORARY SANITARY FACILITIES

- A. The Contractor and subcontractors may use Owner designated restroom facilities located on the premises. The Contractor shall be responsible for maintaining the designated restroom facilities in a clean and sanitary condition or the privilege may be revoked. Coordinate restroom use with the Owner's Authorized Representative.
- B. Do not discharge liquid wastes into sewers or drainage facilities, containing excessive amounts of soil, construction debris, chemicals, oils and similar contaminants that might clog sewers or pollute waterways. The contractor shall bear the cost of any damages to the sewer system, caused directly or indirectly by his crews or subcontractors.

#### 1.12 WASTE DISPOSAL SERVICE

- A. If existing sewers or drainage facilities cannot be lawfully used for discharge of liquid waste, provide containers to remove and dispose of waste off Site in a lawful manner. See Section 01732, Waste Management
- B. Provide solid waste disposal and recycling facilities for the removal of construction related materials, trash and debris, in accordance with Section 01732. No on-site area is available for a 'roll-off' dumpster location. Coordinate with the City of Portland and the Owner's Authorized Representative the 'hooding' of parking meters and the use of public right-of-way for rubbish disposal as required.
- C. Do not dispose of hazardous materials in a manner that could allow the materials to enter landfills, waterways or other unapproved facilities. The Contractor shall comply with the hazardous material provisions of OUS General Conditions for Public Improvements Section F, and Division 1 Section 1732.

#### 1.13 CONSTRUCTION AIDS & GENERAL SERVICE FACILITIES

- A. Construction Aids:
  - 1. Design, construct and maintain construction aids and miscellaneous general services facilities as needed to accommodate performance of Work. Construction aids and miscellaneous general services and facilities include, but are not limited to the following:
    - 1) Temporary stairs and ladders.

- 2) Guardrails and barriers.
- 3) Walkways.

2. Provide temporary stairs where ladders are not adequate for proper, safe or efficient performance of Work.
3. Install and maintain temporary walkways around work and to field offices, toilets and other similar areas. Construct walkways of gravel or duckboard units.
4. Provide lifting devices necessary for the proper and efficient movement of materials; provide operating personnel for equipment as required. Provide for use of all hoisting equipment on the project during “off hours” as required to prevent impeding the project schedule.

B. Pollution Control:

1. Provide general protection facilities, operate temporary facilities, conduct construction activities, and enforce strict discipline for personnel on Site by methods which comply with environmental regulations, and that minimize possibility that air, water and subsoil may be contaminated or polluted, or that other undesirable effects may occur from performance of Work.

C. Noise Control:

1. Contractor shall provide and maintain adequate and effective mufflers, sound barriers and controls for all construction equipment so that noise from this equipment can be controlled to satisfaction of Owner. Coordinate with Owner’s Authorized Representative when construction work requires use of air hammers or other objectionable noisy equipment. Comply with all laws and regulations applicable the noise pollution abatement and workplace noise. See Section 01734.
2. Rotohammering, grinding, drilling or other excessively noisy operations shall be coordinated with Owner’s Authorized Representative and scheduled to avoid impacting building occupants. Jack hammering shall not be allowed at existing building interiors.

D. Dust Control:

1. All streets, roads or detours used for hauling materials shall be oil dust treated as required to prevent dust, or continually watered to prevent dust. Dust prevention measures, both indoors and outdoors shall be continuous until Final Acceptance by Owner.
2. Provide interior dust control measures, such as temporary partitions, taping of air spaces at doors, maintenance of filters and protection of ducts, etc., as required to control dust. Coordinate to prevent accidental activation of particulate-sensing fire detection system as described under requirements for Hot Work Permit.

E. Erosion and Sediment Control:

1. Follow city approved master erosion control plan, when applicable. Maintain copy on site.

## 1.14 TEMPORARY ENCLOSURES

- A. Security:
  - 1. The Contractor shall be responsible for any and all protections required during performance of the work, and shall be responsible for any and all damages as specified in OUS General Conditions for Public Improvement Contracts Section G1.1. 2. The Owner will not be responsible for protection of materials or equipment from vandalism or theft. Security is the responsibility of the Contractor.
- B. Provide security and facilities to protect Work, existing facilities, and Owner's operations from unauthorized entry, vandalism or theft.
- C. Maintain a security program continuously throughout Project, until Owner occupancy or Owner acceptance precludes, need for security program.
- D. Barriers:
  - 1. Comply with recognized standards and code requirements for erection of substantially adequate barriers where needed to prevent accidents and losses. Paint with appropriate colors, graphics and warning signs to inform construction personnel and public of hazard of concern. Provide lighting and flashing signals as required.
  - 2. Provide barriers to prevent unauthorized entry to construction areas to allow for Owner's use of site, and to protect existing facilities and adjacent properties from damage from construction operations and demolition.
  - 3. Provide barricades and covered walkways required by governing authorities for public rights-of-way and for public access to existing building.
  - 4. Protect non-owned vehicular traffic, stored materials, site and structures from damage.
- E. Fencing:
  - 1. Where fencing is required, install general enclosure fence with suitable lock for gates. Locate where indicated on Drawings or as required to substantially complete enclosure around Site or staging/construction operations. Install in manner that will prevent unauthorized persons from easily entering Site. Except when otherwise directed, provide open-mesh, chain-link fencing with posts substantially set in ground, or in moveable concrete blocks.
  - 2. Within five days of Commencement of Work, Contractor shall provide fencing plan for approval by Owner. Plan shall indicate existing fencing to remain, new fencing required and type, location and sequencing of temporary barriers or fencing required for fencing outside primary Site.
- F. Protection of Installed Work:
  - 1. Protect installed Work and provide special protection where specified in individual j Specification Sections.
  - 2. Provide temporary and removable protection for installed Products. Control activity in immediate work area to minimize damage.
  - 3. Protect finished floors, stairs, and other surfaces from traffic, dirt, wear, damage, or movement of heavy objects, by protecting with durable sheet materials.

4. Prohibit traffic or storage upon waterproofed or roofed surfaces. If traffic or activity is necessary, obtain recommendations for protection from waterproofing or roofing material manufacturer.

#### 1.15 PROJECT IDENTIFICATION

##### A. Project Identification Signage:

1. Project Identification Signage will be furnished by Owner and installed by Contractor. Coordinate signage placement with the Owner's Authorized Representative.
2. Project Identification Signage shall be installed by the Contractor within five (5) days of delivery by the Owner and shall be removed by the Contractor following notice of Substantial Completion and prior to Final Completion. Upon removal Project Identification Signage shall become the property of the contractor.
3. Project Identification Sign will consist of two signs, 4'x8' =32 sq ft area, 3/4" marine plywood mounted. Contractor to provide 4"x4" post or other materials and means to mount sign with bottom of sign 4 feet above ground.

##### B. Project Informational Signs:

1. Contractor shall provide temporary directional signs to direct traffic into and within site. Relocate as Work progress requires.

#### 1.16 FIELD OFFICE

- A. Provide field office area, and storage and staging locations within the defined scope of work area and in a location approved by the Owner's Authorized Representative. Provide temporary lighting, heated and ventilation as specified herein.
- B. Provide plan table, notice boards and other furnishings as require for Contractor's daily operations and as required by the Owner's Authorized Representative.
- C. Provide on-site office equipment as specified herein.
- D. Relocate field office area, and storage and staging location as required to not impede work. At completion of Work, remove buildings, utility service and debris. Restore area to prior condition.

#### 1.17 TRAFFIC REGULATION AND PARKING

##### A. Traffic Control:

- a. Comply with all rules and regulations of Owner, City, State and county authorities regarding closing of public streets to use by public traffic, including pedestrians. No road shall be closed to public except by expressed by permission by Owner and City. Control obstructions and hazards with approved signs, barricades and lights where necessary to protect safety of public. Convenience of general public adjacent to Project, protection of persons and property, and access of emergency vehicles are of prime importance and shall be provided for in satisfactory manner.



- B. Flagging Services:
  - 1. Contractor shall provide trained flaggers and barricade hazardous operations during construction activities requiring the use of street areas, as directed by the Owner's Authorized representative. Equip flaggers and guards on duty with approved red work apparel and stop/slow paddle kept clean and in good condition.
  - 2. Utilize traffic control cones, drums, flares and lights which are approved by the city of Portland Bureau of Transportation. Use flares and lights during hours of low visibility to delineate traffic lanes and guide traffic.
  
- C. Temporary Use of Roads:
  - 1. Provide detours necessary for unimpeded traffic flow.
  - 2. Provide and maintain unobstructed access to fire hydrants.
  - 3. Maintain emergency vehicle top access to the premises.
  
- D. Construction Related Parking Control:
  - 1. Contractor, sub-contractor and employee parking will not be provided on the premises. The purchase of hoods for parking meters from the city of Portland is suggested.
  - 2. Coordinate all construction deliveries with the Owner's Authorized Representative. Purchase and obtain a temporary parking permit from the Portland State University office of Transportation and Parking twenty-four (24) hours prior to anticipated delivery parking need. Temporary construction related parking shall be limited to an assigned staging area as approved in writing by the Owner's Authorized Representative. Designated for Contractor's use.
  - 3. The Contractor shall be responsible for all contractor and sub-contractor parking citations by the City of Portland and the Portland State University office of Transportation and Parking. All citations must be paid prior to submission of Notice of Final Completion and Request for Final Payment.

#### 1.18 TEMPORARY FIRE PROTECTION

- A. Until fire protection needs may be fulfilled by permanent facilities, install and maintain temporary fire protection facilities of types needed to adequately protect against reasonably predictable and controllable fire losses.
  - 1. Provide equipment of adequate capacity to extinguish minor fires in combustible material on the Premises during the construction period.
  - 2. Comply with applicable recommendations of NFPA Standard 10 "Standard for Portable Fire Extinguishers".
  - 3. Maintain equipment in working condition with current inspection certificate attached to each.
  - 4. Locate fire extinguishers where they are most convenient, visible and effective for their intended purpose, but provide no less than one extinguisher on each floor or in each general Work area, at or near each usable stairwell.
  - 5. Store combustible materials in containers in recognized fire-safe areas.
  
- B. Develop and supervise overall fire prevention and first-aid fire protection program for personnel at Project Site.

1. Review needs with local fire department officials and establish procedures to be followed.
2. Smoking is prohibited on the premises. Contractor's personnel are to abide by all rules and regulations regarding smoking and all other fire prevention regulations in force where the Work is to be performed. Smoking is not permitted in structures on the PSU campus.
3. Post warning and information and enforce strict discipline.
4. Maintain unobstructed access to fire extinguishers, fire hydrants, temporary fire protection facilities, stairways and other access routes for fighting fires.
5. Provide supervision of welding operations, combustion type temporary heating units, and similar sources of Ignition for fire.
6. Contractor shall ensure that contractor's employees are familiar with Owner's fire procedures and location of fire hydrants and extinguishers in adjacent parts of building adjacent to the construction area.

#### 1.19 PROGRESS CLEANING

- A. Dirt and debris of all nature caused by execution of Work shall be removed from the Site at end of each work day. Contractor shall be responsible for disposal of all scraps and materials that are relative to this Project.
- B. Remove debris and rubbish from pipe chases, plenums, attics, crawl spaces, and other closed or remote spaces, prior to enclosing space.
- C. Hose all paved areas staged with construction material and generally prepare area of Work for occupancy with no further clean-up required by Owner.
- D. Clean all spilled dirt, gravel or other foreign material caused by construction operations from all streets and roads at conclusion of each day's operations. Cleaning of large areas shall be by grader and front-end loader supplemented by washing with water power brushing and hand labor.
- E. Broom and vacuum clean interior areas prior to start of surface finishing, and continue cleaning to eliminate dust.
- F. Remove waste materials, debris, and rubbish from Site daily and dispose off-site.

#### 1.20 REMOVAL OF UTILITIES, FACILITIES AND CONTROLS

- A. Remove temporary above grade or buried utilities, equipment, facilities, materials, prior to Substantial Completion inspection.
- B. Remove underground installations to a minimum depth of two (2) feet. Grade site as indicated. C. Clean and repair damage caused by installation or use of temporary work.
- C. Restore existing facilities used during construction to original condition. Restore permanent facilities used during construction to specified condition.

END OF SECTION

**SECTION 01550  
CONTRACTOR PARKING**

**PART I - GENERAL**

1.01 DESCRIPTION

- A. All parking costs and expenses incurred by any contractor in the course of doing business on Owner's property are the sole responsibility of such contractor. There is no free parking on the Owner's property. Parking rates for the City of Portland are posted at the parking entrances or on parking meters. Vehicles without permits may be towed away at the expense of the vehicle's owner. Parking is not allowed on any Owner's roadway unless so indicated. The Contractor's authorized representative can obtain parking permits for its employees from the Portland State University Transportation & Parking Services Office, Neuberger Hall (503.725.3442) at prevailing rates. All costs for parking permits, parking in University parking lots and ramps, and any fines incurred by any contractor shall be the responsibility of the contractor.
- B. Contractor shall not park in any area not designated for vehicle parking. It will be the responsibility of such contractor to repair and/or reimburse Owner for any damage to Owner's property caused by contractor's vehicle.
- C. Vehicles to be parked on the Owner's property shall be governed by Owner's Transportation & Parking Services Office.

1.02 RELATED SECTIONS

- A. Additional requirements related to Quality Requirements may be provided as follows:
  - 1. OUS General Conditions
  - 2. Other Sections of the specifications.

END OF SECTION

**SECTION 01565  
TREE AND PLANT PROTECTION**

**PART 1 GENERAL**

1.01 SECTION INCLUDES

- A. Work of this section includes preservation and protection of existing trees and lawn to remain.
- B. A Tree and Plant Protection Plan is in place for the construction of utility tunnels and contractor access.
- C. Any changes to the approved Tree and Protection Plan due to the activities of this construction contract are the responsibility of this contractor.

1.2 GENERAL WORK CONSTRAINTS

- A. Unless indicated otherwise on the documents all existing trees and lawn shall remain and be protected.
- B. No work shall occur within the area outside the construction limits fence.

1.3 COMPENSATION FOR DAMAGE TO EXISTING TREES

- A. The Contractor is responsible for compensating the District for any and all damage to trees and lawn to remain.
- B. Compensation action and amounts shall be as directed and calculated by a certified Arborist selected by the Owner.

**PART 2 PRODUCTS**

2.1 TREE PROTECTION AND WORK LIMIT FENCING

- A. Protective Fencing: 6 foot tall temporary chain link fencing with temporary concrete post bases, if required.

**PART 3 EXECUTION**

3.1 INSTALLATION

- A. Provide additional protective fencing, if required, as approved in the Field by the Owner.
- B. Prior to beginning construction, tour the site with the Owner and outline the location where protective additional fencing shall be installed, if required.
- C. Fencing shall be installed plumb in locations identified in the field by the Owner.
- D. Fencing used to define the edge of construction, where it coincides with the location approved by the Owner for plant protection fence, is acceptable for protection fencing.

3.2 MAINTENANCE

- A. Maintain all installed under contract protective fencing plumb, tight, at full height, and where located in the field by District. Replace damaged fencing with new materials as needed.

3.3 REMOVAL

- A. Remove protective fencing just prior to the site review for Substantial Completion.

END OF SECTION

**SECTION 01600  
CONTRACTOR STAGING**

**PART 1 BLDG ENTRY/EXIT ROUTES & PARKING**

- 1.01 Contractor shall schedule all necessary material stocking, demolition and trash removal through building corridors and elevators during non-peak hours or as approved by the PSU (or "Owner") Project Manager. All materials will be brought into the building through the loading dock or approved entry and transported using the Owner's assigned elevator.
- 1.02 The loading dock or entry is only to be used for loading and unloading. The loading dock or entry will not be used for parking. Vehicles left unattended will be towed at the expense of the Contractor.
- 1.03 Unless stated in a Contract, all parking will be at the expense of the Contractor. All vehicles parked on Owner's property must have a parking permit. The Contractor must arrange and secure for all temporary parking permits. Due to limited space, only work vehicles will be allowed at the worksite, and these may be limited in number. Work vehicles are not required to have a PSU parking permit if enclosed within the Contractor's assigned fenced work area. Contractor shall make every effort to carpool to the worksite when possible. It is the Contractor's responsibility to secure all parking permits or pay the appropriate meter.

**PART 2 STAGING/LAY DOWN AREA**

- 2.01 During each phase of Construction, areas required for staging must be submitted to the Owner at least three (3) weeks in advance of the requirement. The date when the area will be reusable by Owner must be included.
- 2.02 During construction, the Contractor shall provide all security for its materials, offices, staging and construction parking areas, etc. Owner shall have no responsibility for any of these items. Contractor shall also be responsible for maintaining a safe construction area on Owner's property and offsite as well, including, without limitation, keeping all public and private roadways and parking areas clean, safe and functioning. The Contractor shall only be obligated clean up of those portions of public or private roadways and parking which have been affected by Contractor's activities.
  - A. Use of lay down area is for the staging and storing of construction related equipment or material for Contractor construction activities only as related to PSU projects.
  - B. Contractor is responsible for making sure the lay down area complies with all local building and fire codes and regulations and all Owner's safety codes and requirements.

- C. Contractor is responsible for keeping the grounds surrounding the lay down area safe and clean of construction materials, litter, trash, and scrap materials. Continuous housekeeping is required including daily removal of combustible waste and storage of combustible waste in approved metal containers and trash bins with metal lids. Outdoor tool and equipment power cords shall be removed nightly. Clean-up and sweeping to be done on a daily basis at the completion of a work shift.
- D. Contractor is responsible for their own trash management, including removal of trash from campus. Contractor shall comply with recycling guidelines specified in the Contract Documents.
- E. Work & safety rules specified in the Contract Documents apply to lay down areas. Construction Personal Protective Equipment is required in the lay down area.
- F. Owner will not be held liable for any loss or damage to any contractor structures or equipment in the lay down area.
- G. There is no smoking in the lay down area or inside structures or shipping containers in the lay down area. No smoking signs shall be posted at these locations.
- H. Contractor is responsible for keeping all fire and emergency access lanes surrounding the lay down area open at all times. Fire lane parking is subject to immediate tow at Contractor's expense. Fire hydrants must be accessible at all times.
- I. Contractor's portable toilets must be located inside the designated lay down area and maintained to PSU's satisfaction at all times.
- J. Contractors will not be permitted to store any type of construction material on top of their shipping containers or structures for safety reasons. No combustible materials will be permitted to be stored under a storage trailer.
- K. Contractor shall return the lay down area in the same or better condition than when initially used. Payment and/or fees may be withheld until repairs by the Contractor have been completed to PSU's satisfaction.
- L. If outside staging of material is required in unpaved areas, Owner is not responsible for mud, dirt, snow, rain, ice and/or rust on materials.
- M. Materials stored in staging area(s) must be protected from the elements and from damage or degradation as required in contract documents.
- N. Fencing shall be covered with opaque material to prevent seeing inside the fencing.
- O. The lay down area shall be made as small as possible and configured to minimize impact to the daily operations of the campus. Contractor to use laydown area for minimal amount of material inventory as required to provide an efficient construction process.

END OF SECTION

**SECTION 01630**  
**PRODUCT REQUIREMENTS AND SUBSTITUTIONS**

**PART 1 - GENERAL**

1.01 DESCRIPTION

- A. The requirements specified in this section relate to general product requirements substitutions by the Contractor, Sub-contractors and Suppliers performing Work under these Contract Documents and includes:
1. Contractor's Responsibilities
  2. Product Options
  3. Substitution Requests during the Bidding Process
  4. Substitution Requests after the Award of Contract
  5. Substitutions not permitted
  6. Product Delivery, Storage & Handling
  7. Product Installation

1.02 RELATED WORK IN OTHER SECTIONS

- A. Additional Product Option and Substitution Request Information may be provided as follows:
1. OUS General Conditions
  2. Other Sections of these specifications.

1.03 DEFINITIONS

- A. "Products" are materials, machinery, components, equipment, fixtures and other systems incorporated into the Project, regardless of whether they were purchased for the Project or taken from the Contractor's previously purchased inventory. It does not include machinery and equipment used in preparation, fabrication, conveying and erection of the Work.
- B. "Materials" are products that must be substantially cut, shaped, worked, mixed, finished, refined or otherwise fabricated, processed or installed to form units of Work.
- C. "Substitutions" includes proposed changes in products, materials, equipment, and methods of construction required by the Contract Documents.

1.04 REQUESTS FOR SUBSTITUTIONS

- A. Requests for substitution of products in place of those specified shall be in accordance with the Public Improvement Agreement, OUS General Conditions, with Supplemental Conditions, and as specified herein. The Contractor assumes responsibility for the requirements as set forth herein. Any cost or time impact shall be at the Contractors expense.

## 1.05 CONTRACTOR'S RESPONSIBILITIES

- A. In requesting substitution, the Contractor shall be comply with OUS General Conditions for Public Improvement Contracts, This includes but is not limited to the following:
1. Investigate proposed products and determine that they are equal or superior in all respects to products specified.
  2. Provide same guarantee for accepted substitutions as for products specified.
  3. Coordinate installation of accepted substitutions into the Work, making such changes as may be required for the Work to be complete in all respects and within original time constraints.
  4. Waive all claims for additional costs related to substitutions, which consequently become apparent.

## PART 2 -PRODUCTS

### 2.01 PRODUCT OPTIONS

- A. Contractor's Options in selecting products is limited by the requirements of the Contract Documents and governing regulations. They are not controlled by industry traditions or procedures experienced by the Contractor on previous construction projects. Where products or manufactures are specified by name or manufacturer, they shall be assumed accompanied by the term, "or approved equal". Comply with the Contract Document requirements for Substitutions and submittals to obtain review from Architect and Owner's Authorized Representative for use of substitute products.

## PART 3 -EXECUTION

### 3.01 SUBSTITUTION REQUESTS DURING THE BIDDING PROCESS

- A. Substitution requests shall meet the following criteria for review by the Architect and Owner's Authorized Representative:
1. Submit five (5) copies of each request for substitution using the submittal process specified in Division 1, Section 01305, Item 3.01.
  2. Substitutions shall be requested using the Substitution Request Form provided herein.
  3. Itemized comparison of proposed substitution with product or method specified.
  4. Complete data on each material and system for this project only, substantiating compliance of proposed substitution with the Contract Documents.
  5. Complete evidence including test numbers and supporting reports indicating compliance with referenced standards.
  6. A statement from the Manufacturer(s) of the proposed substitution materials stating that any and all warranties required by the contract documents for the originally specified materials can and will be provided for the substitution materials, and that required warranties shall be issued upon successful completion of the Work.
- B. Substitutions shall be requested prior to the Deadline for Request for Change and Protests, and accepted by Addendum prior to the date and time bid materials are due at the PSU Office of Facilities.



### 3.02 SUBSTITUTION REQUESTS AFTER AWARD OF CONTRACT

- A. Substitutions will normally not be considered after date of Contract, except when required due to unforeseen circumstances. Within a period of thirty (30) days after date of Contract, the Owner may, at its option, consider formal written requests for substitution of products in place of those specified, when submitted in accordance with the requirements stipulated herein. Substitution requests shall meet the following criteria for review by the Architect and Owner's Authorized Representative:
1. Submit five (5) copies of each request for substitution using the submittal process specified in Division 1, Section 01305, Item 3.01.
  2. Substitutions shall be requested using the Substitution Request Form provided herein.
- B. To receive consideration, one or more of the following conditions must be documented in any such request:
1. The substitution is required for compliance with final interpretation of code requirements or insurance regulations.
  2. The substitution is required due to unavailability of a specified product, through no fault of the Contractor.
  3. The substitution is required because subsequent information disclosed the inability of the specified product to perform properly or to fit in the designated space.
  4. The substitution is required because it has become clearly evident, in the judgment of the Owner that a substitute would be substantially in the best interest of the Owner in terms of cost, time, or other considerations.
- C. For products specified only by referenced standards, provide products by any Manufacturer meeting standards specified.
- D. For products specified by naming one or more products, provide any product named. If certain conditional requirements are stipulated, each product must comply with these requirements. Requests for approval of substitutions are subject to meeting requirements stipulated above.
- E. For products specified by naming a product to match existing products or systems, provide product of the same name. There is no option and no substitution is allowed.
- F. For each substitution that is accepted, the Contractor shall coordinate the work of all other trades and modify surrounding conditions as required to complete the work to the satisfaction of the Owners Authorized Representative at no additional cost to the Owner.

### 3.03 SUBSTITUTIONS NOT PERMITTED

- A. Submitted without first requesting approval thereof in accordance with requirements of this Section.
- B. Acceptance will require substantial revision of the Contract Documents, except as allowed by Paragraph 3.02 above.

### 3.04 PRODUCT DELIVERY, STORAGE, AND HANDLING

- A. Deliver, store, and handle products according to the manufacturer's recommendations, using means and methods that will prevent damage, deterioration, and loss, including theft.
  - 1. Schedule delivery to minimize long-term storage at the site and to prevent overcrowding of construction spaces.
  - 2. Coordinate delivery with installation time to assure minimum holding time for items that are flammable, hazardous, easily damaged, or sensitive to deterioration, theft, and- other losses.
  - 3. Deliver, handle and store products in accordance with the manufacturer's recommendations, using means and methods that will prevent damage, deterioration and loss. Control delivery schedules to ensure timely delivery for incorporation into the Work, while minimizing long-term storage at the site and preventing overcrowding of the construction area.
  - 4. Deliver products to the site in an undamaged condition in the manufacturer's original sealed container or other packaging system, complete with labels and instructions for handling, storing, unpacking, protecting, and installing.
  - 5. Promptly inspect shipments to assure that products comply with requirements, quantities are correct and products are undamaged.
  - 6. Store products subject to damage by the elements above ground, under cover in a weather tight enclosure, with ventilation adequate to prevent condensation. Maintain temperature and humidity within range required by manufacturer's instructions.

### 3.05 PRODUCT INSTALLATION

- A. Comply with manufacturer's instructions and recommendations for installation of products in the applications indicated. Anchor each product securely in place, accurately located and aligned with other Work.
- B. Clean exposed surfaces and protect as necessary to ensure freedom from damage and deterioration at time of Substantial Completion.

END OF SECTION

**SECTION 01732  
WASTE MANAGEMENT**

**PART 1 -GENERAL**

1.01 PROJECT GOALS

- A. The Owner requires that this project generate the least amount of waste and trash possible.
- B. This project has been designed to comply with SEED (State Energy Efficient Design) criteria. The Contractor, sub-contractors and suppliers shall work with the design team and Owner's Authorized Representative to achieve as sustainable of a project as possible from initial control of the site through final completion.

1.02 RELATED WORK IN OTHER SECTIONS

- A. Additional waste management requirements may be found in the following:
  - 1. OUS General Conditions
  - 2. Other Sections of these specifications.

1.03 DEFINITIONS

- A. Clean: Untreated and unpainted; not contaminated with oils, solvents, caulk, or the like.
- B. Construction and Demolition Waste: Solid wastes typically including building materials, packaging, trash, debris, and rubble resulting from construction, remodeling, repair and demolition operations.
- C. Hazardous: Exhibiting the characteristics of hazardous substances, i.e., ignitibility, corrosivity, toxicity or reactivity.
- D. Non-hazardous: Exhibiting none of the characteristics of hazardous substances, i.e., ignitibility, corrosivity, toxicity, or reactivity.
- E. Nontoxic: Neither immediately poisonous to humans nor poisonous after a long period of exposure.
- F. Recyclable: The ability of a product or material to be recovered at the end of its life cycle and remanufactured into a new product for reuse by others.
- G. Recycle: To remove a waste material from the project site to another site for remanufacture into a new product for reuse by others.
- H. Recycling: The process of sorting, cleansing, treating and reconstituting solid waste and other discarded materials for the purpose of using the altered form. Recycling does not include burning, incinerating, or thermally destroying waste.
- I. Return: To give back reusable items or unused products to vendors for credit.

- J. Reuse: To reuse a construction waste material in some manner on the project site.
- K. Salvage: To remove a waste material from the project site to another site for resale or reuse by others.
- L. Sediment: Soil and other debris that has been eroded and transported by storm or well production run-off water.
- M. Source Separation: The act of keeping different types of waste materials separate beginning from the first time they become waste.
- N. Toxic: Poisonous to humans either immediately or after a long period of exposure.
- O. Trash: Any product or material unable to be reused, returned, recycled, or salvaged.
- P. Waste: Extra material or material that has reached the end of its useful life in its intended use. Waste includes salvageable, returnable, recyclable, and reusable material.

#### 1.4 WASTE MANAGEMENT REQUIREMENTS

- A. The contractor shall familiarize himself with the relevant requirements, provide the necessary documentation and instruct all sub-contractors and suppliers regarding energy efficiency, air quality, demolition, recycling, waste management and final cleaning.
- B. Employ processes that ensure the generation of as little waste as possible due to error, poor planning, breakage, mishandling, contamination, or other factors.
- C. Minimize trash/waste disposal in landfills; reuse, salvage, or recycle as much waste as economically feasible.
- D. Methods of trash/waste disposal that are not acceptable are:
  - 1. Burning on the project site.
  - 2. Burying on the project site.
  - 3. Dumping or burying on other property, public or private.
  - 4. Other illegal dumping or burying.
- E. Regulatory Requirements: Contractor is responsible for knowing and complying with regulatory requirements, including but not limited to Federal, State and local requirements, pertaining to legal disposal of all construction and demolition waste materials.
  - 1. The city of Portland requires all building projects with a permit value of \$50,000 or more to separate and recycle certain materials from the job site. The contractor shall be responsible for assuring recycling at the job site and for completing the pre-construction recycling plan form.

## **PART 2 -PRODUCTS**

- 2.01 Contractor shall submit periodic Waste Disposal Reports; all landfill disposal, incineration, recycling, salvage, and reuse must be reported regardless of to whom the cost or savings accrues. See Division 1 Section 01300 for submittal procedures.

- 2.02 Submit Waste Disposal Reports with each application for progress payment, with details of quantities of trash and waste, means of disposal or reuse, and costs; show both totals to date and since last report. Failure to submit Report will delay payment. Prepare Waste Disposal Reports as follows:
- A. Submit Report on a form acceptable to Owner.
  - B. Landfill Disposal: Include the following information:
    - 1. Identification of material.
    - 2. Amount, in tons or cubic yards, or trash/waste material from the project disposed of in landfills.
    - 3. State the identity of landfills, total amount of tipping fees paid to landfill, and total disposal cost.
    - 4. Include manifests, weight tickets, receipts, and invoices as evidence of quantity and cost.
  - C. Incinerator Disposal: Include the following information:
    - 1. Identification of material.
    - 2. Amount, in tons or cubic yards, of trash/waste material from the project delivered to incinerators.
    - 3. State the identity of incinerators, total amount of fees paid to incinerator, and total disposal cost.
    - 4. Included manifest, weight tickets, receipts, and invoices as evidence of quantity and cost.
  - D. Recycled and Salvaged Materials: Include the following information for each:
    - 1. Identification of material, including those retrieved by installer for use on other projects.
    - 2. Amount, in tons or cubic yards, date removed from the project site, and receiving party.
    - 3. Transportation cost, amount paid or received for the material, and the net total cost or savings of salvage or recycling each material.
    - 4. Include manifests, weight tickets, receipts, and invoices as evidence of quantity and cost.
    - 5. Certification by receiving party that materials will not be disposed of in landfills or by incineration.
  - E. Material Reused on Project: Include the following information for each:
    - 1. Identification of material and how it was used in the project.
    - 2. Amount, in tons or cubic yards.
    - 3. Include weight tickets as evidence of quantity.
  - F. Other Disposal Methods: Include information similar to that described above, as appropriate to disposal method.

## **PART 3 -EXECUTION**

### **3.01 WASTE MANAGEMENT PLAN IMPLEMENTATION**

- A. Designate an on-site person or persons responsible for instructing workers and overseeing documenting results of the Waste Management Plan.
- B. Communication: Distribute copies of the Waste Management Plan to job site foreman, each subcontractor, Architect, and Owner's Authorized Representative.
- C. Instruction: Provide on-site instruction of appropriate separation, handling, and recycling, salvage, reuse, and return methods to be used by all parties at the appropriate stages of the project.
- D. Meetings: Discuss trash/waste management goals and issues at project meetings.
  - 1. Pre-bid meeting
  - 2. Pre-construction meeting
  - 3. Regular job-site meetings.
- E. Facilities: Provide specific facilities for separation and storage of materials for recycling, salvage, reuse, return, and trash disposal, for use by all contractors and installers.
  - 1. Provide containers as required.
  - 2. Provide adequate space for pick-up and delivery and convenience to contractors.
  - 3. Keep recycling and trash/waste bin areas neat and clean and clearly marked in order to avoid contamination of materials.
- F. Hazardous Materials: If, during the course of the Work, the Contractor observes or suspects the existence of Hazardous Materials in the structure or components within the defined scope of work area, the Contractor shall immediately stop Work in the immediate area and notify the Owner's Authorized Representative, who will, under separate contract, facilitate the remove of the hazardous material. The Contractor will be required to schedule ten (10) days of slack or "down" time for the removal of potential unforeseen materials. Any delay caused by asbestos abatement that lasts less than ten (10) days shall not constitute a delay as defined in Section D.2 of the OUS General Conditions for Public Improvement Contracts and shall not result in any additional compensation to the contractor. If removal of the material takes more than ten (10) days, the Contractor shall be entitled to an extension of the completion date for the Work equal to the number of days required for removal, plus reimbursement for Contractor's cost of the Work for only those days in excess of ten (10).
  - 1. Hazardous Material abatement in the defined scope of work area was performed in January 2003. A copy of the Asbestos Abatement Inspection Report shall be provided to the contractor prior to beginning work and shall be maintained on the job site throughout the course of work.
- G. Recycling: Separate, store, protect, and handle at the site identified recyclable waste products in order to prevent contamination of materials and to maximize recyclability of identified materials. Arrange for timely pickups from the site or deliveries to recycling facility in order to prevent contamination of recyclable materials.

- H. Reuse of Materials On-Site: Set aside, sort, and protect separated products in preparation for reuse.
- I. Salvage: Set aside, sort, and protect products to be salvaged for reuse off-site.

END OF SECTION

**SECTION 01734  
INDOOR AIR QUALITY**

**PART 1 -GENERAL**

**1.01 PROJECT GOALS**

- A. The owner and building tenants will occupy adjacent areas of the premises during the entire period of construction. The Contractor shall maintain indoor air quality of occupied spaces throughout the construction period to permit normal operations and upon substantial completion provide premises and building systems that meet minimal indoor air quality standards as described herein.
  
- B. Dust and Airborne Particulates: Prevent dust and other particulates from entering HVAC ducts and equipment, and from migrating into occupied spaces.
  - 1. Cleaning of existing ductwork to remain is not contemplated under this contract. Verify the condition of existing ducts and equipment prior to starting work.
  - 2. The Contractor shall bear the cost of duct and equipment cleaning required due to failure to protect ducts and equipment from construction dust.
  - 3. The Contractor shall coordinate with the Owner's Authorized Representative and provide adequate barriers, taping, ventilation and filters to prevent dust, fumes, odors, vapors or other agents from impacting normal operations in adjacent occupied spaces. Failure to do so may result in suspension of Work at the Contractors expense.
  - 4. Procedures and products have been specified to minimize indoor air pollutants:
    - A) Furnish Products meeting or exceeding the specifications.
    - B) Avoid construction practices that could result in contamination of installed products leading to indoor air pollution.

**1.02 RELATED WORK IN OTHER SECTIONS**

- A. Additional information related to Indoor Air Quality management requirements, temporary facilities required and Owner's remedies for non-compliance may be found in the following:
  - 1. OUS General Conditions
  - 2. Other Sections of these specifications.

**1.03 REFERENCES**

- A. ASHRE 62 – Ventilation For Acceptable Indoor Air Quality; 1999 and Addenda.
- B. ASHRAE Std. 129 – Measuring Air-Change Effectiveness; 1997.
- C. Oregon Administrative Rules Sections; 437-002—0081, 437-002-0107, 437-002-0382.
- D. Oregon Administrative Rules Section 437-003-0027.



## 1.04 DEFINITIONS

- A. Absorptive Materials: Gypsum board, acoustical ceiling tile and panels, carpet and carpet tile, fabrics, fibrous insulation, and other similar products.
- B. Contaminates: Gases, vapors, smoke, airborne mold and mildew, and other regulated pollutants including but not limited to construction related noise.
- C. Particulates: Dust, dirt and other airborne solid matter.
- D. Wet Work: Concrete, plaster, coatings, adhesives and other products that emit water vapor or volatile organic compounds during the installation, drying, or curing processes.

## **PART 2 -PRODUCTS**

NOT USED

## **PART 3 -EXECUTION**

### 3.1 CONSTRUCTION PROCEDURES

- A. Prevent the absorption of moisture and humidity by absorptive materials by:
  - 1. Sequencing the delivery of such materials so that they are not present in the building until wet work is completed and dry.
  - 2. Delivering and storing such materials in fully sealed moisture-impermeable packaging.
  - 3. Provide sufficient ventilation for drying of wet work without impacting delivery schedules.
- B. Begin temporary construction heating and ventilation as soon as the work limits are substantially enclosed.
- C. If extremely dusty or dirty work must be performed, coordinate the temporary shut down of HVAC systems with the Owner's Authorized Representative. The Owner's Authorized Representative may require work by the Contractor outside of normal business hours (8:00 AM through 5:00 PM) if HVAC systems serving occupied areas are required to be shut down for extended periods.
- D. When working in a portion of an occupied building, provide barriers necessary to prevent movement of air from the construction area to occupied areas.
- E. HVAC equipment and ductwork SHALL NOT be used for ventilation during construction:
  - 1. Provide minimum temporary ventilation equivalent to 1.5 air changes per hour. Increase as required for wet work.
  - 2. Exhaust directly to outside. The Owner's Authorized Representative shall approve the Contractors exhaust venting plan including; equipment, routing and outlet prior to installation.
  - 3. Seal HVAC air inlets and outlets immediately after duct installations.

- F. Do not store construction materials or waste in mechanical rooms, electrical rooms or exit ways. Coordinate all materials storage with the Owner's Authorized Representative.
- G. Prior to use of return air ductworks without intake filters, remove dust and debris generated by construction activities.
  - 1. Inspect duct intakes, return air grills, and terminal units for dust.
  - 2. Clean plenum spaces, including top sides of lay-in ceilings, outsides of ducts, tops of pipes and conduits.
  - 3. Clean tops of doors and frames.
  - 4. Clean mechanical and electrical rooms where work is performed, including the tops of pipes, ducts, conduits, equipment and supports.
  - 5. Clean return plenums of air handling units.
  - 6. Remove intake filters last, after all cleaning operations are complete.
- H. Do not perform dusty or dirty work after starting use of return air ducts without intake filters.
- I. Use other relevant recommendations of SMACNA IAQ Guidelines for Occupied Buildings Under Construction to avoid unnecessary contaminants due to the construction process.
- J. Perform Air Contaminant Testing as specified herein.

### 3.02 AIR CONTAMINANT TESTING:

- A. Perform air contaminate testing before starting construction, as a baseline for evaluating post-occupancy test results, as specified herein.
- B. Perform air contaminate testing prior to submitting for substantial completion.
- C. Do not start air contaminant testing until:
  - 1. All other construction operations are substantially complete.
  - 2. HVAC systems have been tested adjusted, and balanced for proper operation.
  - 3. New HVAC unit air filters have been installed.
- D. Collect the following indoor air samples from representative spaces of the work areas:
  - 1. Collect samples while windows and exterior doors are closed, HVAC system is in normal operation and the building premises are unoccupied.
  - 2. Collect samples in each space served by the new air handling system.
  - 3. Collect air samples between a height of 48 inches and 72 inches above finished floor.
  - 4. Collect samples from same locations on three separate days and average the results of the three samples.
- E. Submit a report analyze the air samples and compare them against the pre-construction baseline (See Section 01300 for submittal procedure).
- F. Air Contamination Concentrations and Limits shall be as set forth in the Oregon Administrative Rules and as follows (the most restrictive shall apply):

1. Carbon Monoxide: Measure in ppm, in relation to outside air, at air intake; not more than outside air.
2. Airborne Mold and Mildew: Measure in relation to outside air, at air intake, but in no case less than 48 inches above finish grade; not more than outside air.
3. Formaldehyde: Measure in micrograms per cubic meter in relation to outside air, at air intake. Not more than 20 micrograms per cubic meter higher than outside air.
4. Total Volatile Organic Compounds (TVOC): Measure in micrograms per cubic meter, in relation to outside air, at air intake. Not more than 200 micrograms per cubic meter higher than outside air.
5. Total Particulate Matter: Measure in micrograms per cubic meter, in relation to air, at air intake, not more than 20 micrograms per cubic meter higher than outside air.

3.03 VENTILATION EFFECTIVENESS TESTING:

- A. Perform ventilation effectiveness testing prior to substantial completion.
- B. Do not begin ventilation effectiveness testing until:
  1. HVAC systems have been tested adjusted, and balanced for proper operation.
  2. Air contamination testing has been completed satisfactorily.
  3. New HVAC unit air filter have been installed.
- C. Test each air handler zone in accordance with ASHRAE 129.
- D. If calculated air change effectiveness for a particular zone is less than 0.9 due to inadequate balancing of the system, adjust and retest at no additional cost to the Owner.

END OF SECTION

## **SECTION 01780 CONTRACT CLOSEOUT**

### **PART 1 -GENERAL**

#### **1.01 DESCRIPTION:**

- A. The requirements specified in this Section relate to all Contractors individually performing Work under these Contract Documents and include:
  - 1. Final Cleaning
  - 2. System Start-up, Testing & Adjusting
  - 3. Operations & Maintenance Manuals
  - 4. Warranties & Bonds
  - 5. Training
  - 6. Spare Parts & Extra Quantities
  - 7. Project Record Documents
  - 8. Final Review and Payment
- B. Project closeout is a term used to describe certain collective project requirements, indicating Work under this Contract that is fulfilled near the end of the Contract time in preparation for Final Completion, as well as Final Payment to the Contractor.
- C. Special requirements for individual units of work may be included in appropriate Specification Sections of this Project Manual.

#### **1.02 RELATED WORK IN OTHER SECTIONS**

- A. Additional Contract closeout requirements may be provided as follows:
  - 1. OUS General Conditions
  - 2. Supplementary General Conditions
  - 3. Section 01300, Submittals
  - 4. Other Sections of these Specifications

### **PART 2 - PRODUCTS – NOT APPLICABLE**

### **PART 3 – EXECUTION**

#### **3.01 GENERAL DESCRIPTION:**

- A. Substantial Completion shall be defined per OUS General Conditions for Public Improvement Contracts Section A.1, and Notification of Substantial Completion by the Contractor to the Owner shall be through the Owner's Representative as specified in Section K.4 of the same and as supplemented by OUS Supplemental General Condition SG-6. See Division 1, Section 01300 for general Submittal Review Procedure.
- B. Submit Certificate of Substantial Completion with accompanying 'punchlist' and date for punchlist completion to the Owner's Authorized Representative once the Contract Documents have been reviewed, Work has been inspected and all prerequisites to substantial completion have been addressed.

- C. Prior to signing the Certificate of Substantial Completion, the Owner's Authorized Representative will perform one Substantial Completion review of the Work. The Contractor shall pay the cost of additional Substantial Completion reviews of the Work.

### 3.02 FINAL CLEANING

- A. Perform final cleaning of all items of Work prior to Substantial Completion review of the Work. Employ professional cleaners for final cleaning. Clean each surface or unit of work to condition expected from normal commercial building cleaning and maintenance program. Comply with all manufacturer's recommendations. Complete the following prior to requesting Owner's Authorized Representative review of the Work for Substantial Completion certification:
  - 1. Clean interior and exterior glass and surfaces exposed to view; remove temporary labels, stains and foreign substances, polish transparent and glossy surfaces.
  - 2. Vacuum all carpeted, fabric and other soft surfaces.
  - 3. Clean all Contractor and Owner provided equipment and fixtures.
  - 4. Clean or replace all filters of operating equipment.
  - 5. Clean debris from roofs, gutters, downspouts and drainage systems impacted by the Work.
  - 6. Clean the Project Site and adjacent areas impacted by the Work, including landscaped and parking areas, or rubbish, litter and other foreign substances. Sweep paved areas to broom clean condition. Remove stains, spills and other foreign deposits. Rake grounds that are neither paved nor planted to smooth, even-textured surface.
  - 7. Re-clean areas and equipment prior to inspection for Final Completion, if dirtied in completion of punchlist work.
- B. Unless otherwise directed by the Owner's Authorized Representative, remove temporary protective devices and facilities, which were installed during the course of the Work to protect previously completed work from the remainder of the construction to be completed, or to protect the public.
- C. Comply with all safety standards and governing regulations for cleaning and disposal of waste materials in accordance with Division 1, Section 01732 and the OUS General Conditions for Public Improvement Contracts.

### 3.03 SYSTEM START-UP, TESTING & ADJUSTING

- A. The project has been designed to comply with SEED (State Energy Efficient Design) criteria. Coordinate with the Owner's Authorized Representative the system start-up, testing, adjusting and balancing to comply with the Owner's Commissioning requirements.
- B. The Contractor shall coordinate the scheduling for the start-up and testing of various equipment and systems provided by the Contractor and Owner with the Owner's Authorized Representative.
- C. Notify the Owner's Authorized Representative a minimum of fourteen (14) calendar days prior to the start-up or testing of each item.

- D. The Contractor shall submit to the Owner's Authorized Representative for review and approval, a minimum of fourteen (14) calendar days prior to the start-up or testing, five (5) copies of the following:
1. A paragraph-by-paragraph program of the Contractor's proposed testing procedure, developed to demonstrate compliance with the contract documents.
  2. Check off sheets for the review of each item of equipment and system.
  3. Each program and check off sheet shall provide the following information:
    - 1) Project information required by Division 1, Section 01300, Item 1.05.
    - 2) Product information required by Division 1, Section 01300, Item 3.06.
    - 3) Other information as required the fully describe the item.
    - 4) Provide spaces for testing "Review" sign off by Owner's Authorized Representatives.
- E. Verify that each piece of equipment or system has been checked for proper connection of services, lubrication, drive rotation, belt tension, control sequencing or other conditions that could cause damage.
- F. Verify that tests, meter readings and specified electrical characteristics agree with those required by equipment or system manufacturers.
- G. Verify that wiring, piping and support components for equipment are complete and tested.
- H. Execute start-up under the supervision of the Owner's Authorized Representative(s), the responsible manufacturer's representative, Contractor's personnel in accordance with the manufacturer's recommendations.
- I. Submit five (5) copies of all Installation, Adjustment and Balancing and Testing Reports for each piece of equipment and system in accordance with the Submittal Review Procedures, specified in Division 1, Section 01300, Item 3.01.
- J. Operating equipment and systems shall be tested in the presence of the Owner's Authorized Representatives and demonstrate compliance with the Contract Documents and the manufacturer's recommendations:
1. Testing shall be conducted under operating conditions as specified by the Owner's Authorized Representatives.
  2. Copies of all test reports shall be included in the Project Record Documents.
- K. All elements of systems shall be tested to demonstrate that total systems satisfy all requirements of the Contract Documents. Test each piece of equipment for proper operation, followed by each subsystem, followed by entire system, followed by interfaces with other major systems.
- L. The Contractor shall provide all materials and equipment required for equipment and system testing.
- M. The Contractor shall perform the following minimal tests and additional tests as required by the Owner's Authorized Representative:

1. System shall be checked for proper installation, and shall be adjusted and calibrated to verify that it is ready to function as specified.
2. All system elements shall be checked to verify that they have been properly installed and that all connections have been made correctly.
3. All discrete elements and sub-systems shall be adjusted and balanced and shall be checked for proper operation.

#### 3.04 OPERATIONS & MAINTENANCE MANUALS

- A. The Contractor shall provide Operations and Maintenance Manuals for review and project record documentation in accordance with OUS General Conditions for public Improvement Contract Section K.2, in accordance with the Submittal Review Procedures, specified in Division 1, Section 01300, Item 3.01.
- B. Include Operation and Maintenance instructions complete with technical information, required warranties & bonds and name, address and phone number of the Contractor(s) and Manufacturer(s) of each material and product. Bind in separate three-ring binders. Label similar to Project Documents binder with dividers by Specification section and supplier.

#### 3.05 WARRANTIES & BONDS

- A. Provide all warranties and bonds specified in other Sections of this project manual.
- B. Include all required warranties and bonds in the Operations and Maintenance Manuals in accordance with Item 2.04 herein.
- C. List Subcontractor, supplier and manufacturer, with address and telephone number of responsible principles.
- D. Verify that documents are in proper form, contain all information, and are notarized as applicable.
- E. Co-execute documents as required.

#### 3.06 TRAINING

- A. The Contractor shall coordinate with the Owner's Authorized Representative training sessions for all equipment and systems in accordance with OUS General Conditions for Public Improvement Contract Section K.5.

#### 3.07 SPARE PARTS & EXTRA QUANTITIES

- A. The Contractor shall provide spare parts and extra quantities in accordance with OUS General Conditions for public Improvement Contract Section K.5.
- B. The Contractor shall submit in accordance with Division 1 Section 01300 Item 3.01, five (5) copies of the following:
  1. Check off sheets for the review of each item of material or product for which extra quantities are required.
  2. Each check off sheet shall provide the following information:

- 1) Project information required by Division 1, Section 01300, Item 1.05.
  - 2) Product information required by Division 1, Section 01300, Item 3.06.
  - 3) Amount of extra parts or quantity required.
  - 4) Provide spaces for testing "Review" sign off by Owner's Authorized Representatives.
- C. Coordinate delivery to the Owner with the Owner's Authorized Representative and submit receipts of delivery corresponding to spare parts and extra quantities check off sheet.

### 3.08 PROJECT RECORD DOCUMENTS

- A. Submit three (3) copies of the Project Record Documents for review in accordance with Division 1 Section 01300 Item 3.01. The Project Record Documents shall be organized to include the following information:
1. Title and date of Project, Owner's Project Number
  2. Table of Contents
  3. Specifications
  4. As-Built Drawings (blueprints or photocopies)
  5. Inspection Reports, as applicable
  6. Warranty(ies), as applicable
  7. Operations and Maintenance Instructions
  8. Approved and stamped Shop Drawings, Product Data and Samples (Provide 1 set of reproducible copies for Owner's file, in Microsoft Word or AutoCAD 2000 electronic formats, or on 3 MIL thick double sided and toothed Mylar.)
- B. Bind each copy of the Project Record Documents in a black, hard cover, three-ring binder with each Section clearly indexed with tabbed divider pages.
- C. The project team list shall include the address and phone number of the Owner, Contractor, inspectors, subcontractors, and the materials manufacturers.
- D. Legibly mark each Specification Section to indicate actual as-built conditions. The as-built Specifications shall clearly indicate changes in the Work made by Addendum(a) and/or Change Order(s), actual materials used, and actual Manufacturer(s) used.
- E. Legibly mark the drawings to indicate actual "as-built conditions." The drawings shall clearly indicate changes in the Work made by Addendum(a) and/or Change Order(s). The Owner shall to modify CAD documents into a "recorded as-built" base for Owner's usage, based on information provided by Contractor.
- F. Include inspection reports and field reports, if applicable.
- G. Include a copy of required Warranty(ies) clearly marked to identify the Owner's responsibilities under the terms of the Warranty(ies).
- H. Make corrections to all Project Record Documents and resubmit as part of Final Completion Review.



- 3.09. The Contractor shall comply with all terms of OUS General Conditions for Public Improvement Contract Sections E.6 and I.1, unless otherwise amended herein, prior to filing Notice of Final Completion or requesting Final Payment.
- 3.10. The Contractor shall return all keys requested for access to buildings and work areas and obtain a deposit refund, as specified in Division 1, Section 01040, Item 1.09.
- 3.11. The Contractor shall notify all Subcontractors in writing of incomplete and/or incorrect items and the anticipated filing of Final Completion. Notify far enough in advance of the completion date that the Work can be completed on schedule. Said Work shall be immediately corrected.
- 3.12. Submit to the Owner's Authorized Representative Lien Releases in accordance with OUS General Conditions for Public Improvement Contract Section K.8.
- 3.13. The Contractor shall provide the Owner with an unconditional Certificate of Occupancy from the local building officials, in accordance with OUS General Conditions for Public Improvement Contract Section K.8.
- 3.14. Notify the Owner or Owner's Authorized Representative in writing that all items are complete and ready for Final Completion review and that the Work product is fully usable.
- 3.15. Submit three (3) copies of all record documents for Final Completion review at this time.
- 3.16. The Owner's Authorized Representative will review all documents. The Owner's Authorized Representative will review all Work that has been certified as complete to the best knowledge of the Contractor. The Owner or Owner's Representative will also list all remaining incomplete punchlist Work and assign a probable value and time to complete such uncompleted Work.
- 3.17. The Owner's Authorized Representative will review the Work for conformance. Time is of the essence on this project. If the Work is found to be in nonconformance, the Owner's Representative will notify the Owner of the nonconforming items and probable value and time for completion. Nonconforming items will require retainage of monies to ensure that the Contractor will complete all Work within the time established by the Public Improvement Contract and as amended by executed Change Orders.
- 3.18. The Contractor shall make the required corrections to the Work expeditiously. Sufficient retainage monies will be held to pay for uncompleted Work, should the Contractor fail to perform. A letter will be addressed to the Contractor noting the project status and the monies available for a partial-final payment upon receipt of billing.
- 3.19. When Contract closeout procedures are completed and all Punchlist deficiencies have been corrected, final acceptance by the Owner will be documented. The Contractor will receive written notice of acceptance of the Work and notification that final payment may be billed and released. Note that final wage rate submittal and documentation of all BOLI fees are required prior to final payment.
- 3.20. The Contractor shall be responsible for all parking citations received in relation with the project from the City of Portland and the Portland State University office of Transportation and Parking. All citations must be paid prior to submission of notice of Final Completion and Request for final Payment.

- 3.21. All warranties shall commence and become effective in accordance with Section I of the OUS General Conditions for Public Improvement.

END OF SECTION

SECTION 02 41 19

SELECTIVE STRUCTURE DEMOLITION

PART 1 GENERAL

1.1 SUMMARY

- A. Section Includes:
  - 1. Demolishing designated building equipment and fixtures.
  - 2. Demolishing designated construction.
  - 3. Cutting and alterations for completion of the Work.
  - 4. Removing designated items for reuse and Owner's retention.
  - 5. Protecting items designated to remain.
  - 6. Removing demolished materials.

1.2 SUBMITTALS

- A. Section 01300 - Submittal Procedures: Requirements for submittals.
- B. Demolition Schedule: Indicate overall schedule and interruptions required for utility and building services.
- C. Shop Drawings:
  - 1. Indicate demolition and removal sequence.
  - 2. Indicate location and construction of temporary work.

1.3 QUALITY ASSURANCE

- A. Conform to applicable code for demolition work, dust control, products requiring electrical and other utilities disconnection and re-connection.
- B. Conform to applicable code for procedures when hazardous or contaminated materials are discovered.
- C. Obtain required permits from authorities having jurisdiction.
- D. Perform work in accordance with state standard.
- E. Maintain one copy of each document on site.

1.4 PRE-INSTALLATION MEETINGS

- A. Section 01040 – Project Coordination: Construction Coordination
- B. Convene minimum one week prior to commencing work of this section.

## 1.5 SEQUENCING

- A. Section 01040 – Project Coordination
- B. Sequence activities in the following order:
  - 1. Do not remove any existing structure for temporary or new permanent supports are in place.
  - 2. Do not remove any temporary shoring before new permanent supports are in place.
- C. Owner will conduct salvage operations before demolition begins to remove materials Owner chooses to retain.

## 1.6 SCHEDULING

- A. Section 01040 - Project Coordination.
- B. Schedule Work to coincide with new construction.
- C. Cooperate with Owner in scheduling noisy operations and waste removal that may impact Owners operation in adjoining spaces.
- D. Perform noisy, malodorous, dusty, or other work:
  - 1. During times approved by owner – submit a schedule for approval.
- E. Coordinate utility and building service interruptions with Owner.
  - 1. Do not disable or disrupt building fire or life safety systems without three days prior written notice to Owner.
  - 2. Schedule tie-ins to existing systems to minimize disruption.
  - 3. Coordinate Work to ensure fire sprinklers, fire alarms, smoke detectors, emergency lighting, exit signs and other life safety systems remain in full operation in occupied areas.

## 1.7 PROJECT CONDITIONS

- A. Conduct demolition to minimize interference with adjacent and occupied building areas.
- B. Cease operations immediately if structure appears to be in danger and notify Engineer. Do not resume operations until directed.

## PART 2 PRODUCTS

Not Used.

## PART 3 EXECUTION

### 3.1 PREPARATION

- A. Notify affected utility companies before starting work and comply with their requirements.
- B. Mark location and termination of utilities.
- C. Erect, and maintain temporary barriers and security devices at locations indicated, including warning signs and lights, and similar measures, for protection of the public, Owner, and existing improvements indicated to remain.
- D. Erect and maintain weatherproof closures for exterior openings.
- E. Erect and maintain temporary partitions to prevent spread of dust, odors, and noise to permit continued Owner occupancy.
- F. Prevent movement of structure; provide temporary bracing and shoring required to ensure safety of existing structure.
- G. Provide appropriate temporary signage including signage for exit or building egress.
- H. Do not close or obstruct building egress path.
- I. Do not disable or disrupt building fire or life safety systems without 3 days prior written notice to Owner.

### 3.2 DEMOLITION

- A. Conduct demolition to minimize interference with adjacent and occupied building areas.
- B. Maintain protected egress from and access to adjacent existing buildings at all times.
- C. Do not close or obstruct roadways or sidewalks without permits.
- D. Cease operations immediately when structure appears to be in danger and notify Engineer.
- E. Disconnect and remove designated utilities within demolition areas.
- F. Cap and identify abandoned utilities at termination points when utility is not completely removed. Annotate Record Drawings indicating location and type of service for capped utilities remaining after demolition.
- G. Demolish in orderly and careful manner. Protect existing improvements, supporting structural members, piping and new tunnels.
- H. Carefully remove building components indicated to be reused.
  - 1. Disassemble components as required to permit removal.
  - 2. Package small and loose parts to avoid loss.

3. Mark components and packaged parts to permit reinstallation.
  4. Store components, protected from construction operations, until reinstalled.
- I. Remove demolished materials from site except where specifically noted otherwise. Do not burn or bury materials on site.
  - J. Remove materials as Work progresses. Upon completion of Work, leave areas in clean condition.
  - K. Remove temporary Work.

END OF SECTION

SECTION 02 41 23

MECHANICAL DEMOLITION

PART 1 GENERAL

1.1 SUMMARY

- A. Section Includes:
  - 1. Demolishing designated equipment, piping and insulation.
  - 2. Cutting and alterations for completion of the Work.
  - 3. Removing designated items.
  - 4. Protecting items designated to remain.
  - 5. Removing demolished materials.

1.2 SUBMITTALS

- A. Section 01300 - Submittal: Requirements for submittals.
- B. Demolition Schedule: Indicate overall schedule and interruptions required for utility and building services.
- C. Shop Drawings:
  - 1. Indicate demolition and removal sequence.
  - 2. Indicate location of items designated for reuse and Owner's retention.
  - 3. Indicate location and construction of temporary work.

1.3 CLOSEOUT SUBMITTALS

- A. Section 01780 - Contract Closeout: Closeout Procedures.
- B. Project Record Documents: Accurately record actual locations of capped utilities, concealed utilities discovered during demolition, subsurface obstructions, etc.
- C. Operation and Maintenance Data: Submit description of system, inspection data, and parts lists.

1.4 QUALITY ASSURANCE

- A. Conform to applicable code for demolition work, dust control, products requiring electrical disconnection and re-connection.
- B. Conform to applicable code for procedures when hazardous or contaminated materials are discovered.
- C. Obtain required permits from authorities having jurisdiction.
- D. Perform Work in accordance with State standard.

- E. Maintain one copy of each document on site.

#### 1.5 PRE-INSTALLATION MEETINGS

- A. Section 01040 – Project Coordination: Construction Coordination.
- B. Convene minimum one week prior to commencing work of this section.

#### 1.6 SEQUENCING

- A. Section 01040 – Project Coordination
- B. Sequence activities to avoid extended shutdowns of building systems.
- C. Owner will conduct salvage operations before demolition begins to remove materials Owner chooses to retain.

#### 1.7 SCHEDULING

- A. Section 01040 – Project Coordination: Work Schedules
- B. Schedule Work to coincide with new construction.
- C. Cooperate with Owner in scheduling noisy operations and waste removal that may impact Owners operation.
- D. Perform noisy, malodorous, dusty, or other work:
  - 1. During times approved by the Owner – Submit a schedule for approval.
- E. Coordinate utility and building service interruptions with Owner.
  - 1. Do not disable or disrupt building fire or life safety systems without three days prior written notice to Owner.
  - 2. Schedule tie-ins to existing systems to minimize disruption.
  - 3. Coordinate Work to ensure fire sprinklers, fire alarms, smoke detectors, emergency lighting, exit signs and other life safety systems remain in full operation in occupied areas.

#### 1.8 PROJECT CONDITIONS

- A. Conduct demolition to minimize interference with adjacent and occupied building areas.
- B. Cease operations immediately if structure appears to be in danger and notify Architect/Engineer. Do not resume operations until directed.



## PART 2 PRODUCTS

NOT USED

## PART 3 EXECUTION

### 3.1 PREPARATION

- A. Notify affected utility companies before starting work and comply with their requirements.
- B. Mark location and termination of utilities.
- C. Erect, and maintain temporary barriers and security devices at locations indicated, including warning signs and lights, and similar measures, for protection of the public, Owner, and existing improvements indicated to remain.
- D. Erect and maintain temporary partitions to prevent spread of dust, odors, and noise to permit continued Owner occupancy.
- E. Prevent movement of structure; provide temporary bracing and shoring required to ensure safety of existing structure.
- F. Provide appropriate temporary signage including signage for exit or building egress.
- G. Do not close or obstruct building egress path.
- H. Do not disable or disrupt building fire or life safety systems without 3 days prior written notice to Owner.

### 3.2 DEMOLITION

- A. Conduct demolition to minimize interference with adjacent and occupied building areas.
- B. Maintain protected egress from and access to adjacent existing buildings at all times.
- C. Do not close or obstruct roadways sidewalks without permits.
- D. Cease operations immediately when structure appears to be in danger and notify Architect/Engineer.
- E. Disconnect and remove designated utilities within demolition areas.
- F. Cap and identify abandoned utilities at termination points when utility is not completely removed. Annotate Record Drawings indicating location and type of service for capped utilities remaining after demolition.
- G. Demolish in orderly and careful manner. Protect existing improvements, supporting structural members and piping and insulation.

- H. Carefully remove building components indicated to be reused.
  - 1. Disassemble components as required to permit removal.
  - 2. Package small and loose parts to avoid loss.
  - 3. Mark components and packaged parts to permit reinstallation.
  - 4. Store components, protected from construction operations, until reinstalled.
- I. Remove demolished materials from site except where specifically noted otherwise. Do not burn or bury materials on site.
- J. Remove materials as Work progresses. Upon completion of Work, leave areas in clean condition.
- K. Remove temporary Work.

### 3.3 SCHEDULES

- A. Protect the materials and equipment remaining.
- B. Demolish the following materials and equipment:
  - 1. Piping and associated specialties and supports.
  - 2. Concrete Pads.
  - 3. Insulations.
  - 4. See Demo Drawings.

END OF SECTION

SECTION 02 41 26

SELECTIVE ELECTRICAL DEMOLITION

PART 1 GENERAL

1.1 SUMMARY

- A. Section Includes:
  - 1. Removal of existing electrical equipment, wiring, and conduit in areas to be remodeled; removal of designated construction; dismantling, cutting and alterations for completion of the Work.
  - 2. Disposal of materials.
  - 3. Storage of removed materials.
  - 4. Identification of utilities.
  - 5. Salvaged items.
  - 6. Protection of items to remain as scheduled at end of section as indicated on Drawings.
  - 7. Relocate existing equipment to accommodate construction.

1.2 SUBMITTALS

- A. Section 01300 - Submittals: Requirements for submittals.
- B. Shop Drawings: Indicate demolition location and construction of temporary work. Describe demolition removal procedures and schedule.

1.3 CLOSEOUT SUBMITTALS

- A. Section 01780 – Contract Closeout: Requirements for submittals.
- B. Project Record Documents: Record actual locations of capped conduits and equipment abandoned in place.

1.4 QUALITY ASSURANCE

- A. Perform Work in accordance with Municipality of Portland, OR standard.

1.5 PRE-INSTALLATION MEETINGS

- A. Section 01040 – Project Coordination: Construction Coordination.

1.6 SEQUENCING

- A. Section 01010 – Summary of Work

1.7 SCHEDULING

- A. Section 01040 – Project Coordination: Construction Coordination

- B. Perform noisy, malodorous, dusty, or work:
  - 1. During times approved by the Owner – Submit schedule for approval.
- C. Cease operations immediately when structure appears to be in danger and notify Architect/Engineer. Do not resume operations until directed.

#### 1.8 COORDINATION

- A. Section 01040 Project Coordination: Construction Coordination.
- B. Conduct demolition to minimize interference with adjacent and occupied building areas.
- C. Coordinate and sequence demolition so as not to cause shutdown of operation of surrounding areas.
- D. Shut-down Periods:
  - 1. Arrange timing of shut-down periods of in service panels with Owner. Do not shut down any utility without prior written approval.
  - 2. Keep shut-down period to minimum or use intermittent period as directed by.
  - 3. Maintain life-safety systems in full operation in occupied facilities, or provide notice minimum 3 days in advance.
- E. Identify salvage items in cooperation with Owner.

#### PART 2 PRODUCTS

NOT USED

#### PART 3 EXECUTION

##### 3.1 EXAMINATION

- A. Section 01040 - Project Coordination: Construction Coordination.
- B. Verify wiring and equipment indicated to be demolished serve only abandoned facilities.
- C. Verify termination points for demolished services.

##### 3.2 PREPARATION

- A. Erect, and maintain temporary safeguards, including warning signs and lights, barricades, and similar measures, for protection of the public, Owner, Contractor's employees, and existing improvements to remain.
- B. Temporary egress signage and emergency lighting

### 3.3 DEMOLITION

- A. Demolition Drawings are based on casual field observation and existing record documents. Report discrepancies to Architect/Engineer before disturbing existing installation.
- B. Remove exposed abandoned conduit. Cut conduit flush with walls and floors, and patch surfaces.
- C. Remove conduit, wire, boxes, and fastening devices to avoid any interference with new installation. Remove conduit and wire from demolished equipment back to panelboard or MCC source.
- D. Disconnect electrical systems in walls, floors, and ceilings scheduled for removal.
- E. Reconnect equipment being disturbed by renovation work and required for continue service to or nearest available panel.
- F. Disconnect or shut off service to areas where electrical work is to be removed. Remove electrical fixtures, equipment, and related switches, outlets, conduit and wiring which are not part of final project.
- G. Install temporary wiring and connections to maintain existing systems in service during construction.
- H. Perform work on energized equipment or circuits with experienced and trained personnel.
- I. Remove, relocate, and extend existing installations to accommodate new construction.
- J. Repair adjacent construction and finishes damaged during demolition and extension work.
- K. Remove exposed abandoned grounding and bonding components, fasteners and supports, and electrical identification components, including abandoned components above accessible ceiling finishes. Cut embedded support elements flush with walls and floors.
- L. Clean and repair existing equipment to remain or to be reinstalled.
- M. Protect and retain power to existing active equipment remaining.
- N. Cap abandoned empty conduit at both ends.

### 3.4 REUSABLE ELECTRICAL EQUIPMENT

- A. Carefully remove equipment, materials, or fixtures which are to be reused.
- B. Disconnect, remove, or relocate existing electrical material and equipment interfering with new installation.

- C. Relocate existing lighting fixtures as indicated on Drawings. Clean fixtures and re-lamp. Test fixture to see if it is in good working condition before installation at new location.

3.5 CLEANING

- A. Section 01780 – Contract Closeout: Requirements for cleaning.
- B. Remove demolished materials as work progresses. Legally dispose.
- C. Keep workplace neat.

END OF SECTION

SECTION 05 12 00

STRUCTURAL STEEL FRAMING

PART 1 GENERAL

1.1 SUMMARY

- A. Section Includes:
1. Structural shapes.
  2. Channels and angles.
  3. Hollow structural sections.
  4. Structural pipe.
  5. Structural plates and bars.
  6. Fasteners, connectors, and anchors.
  7. Grout.

1.2 REFERENCES

- A. American Institute of Steel Construction:
1. AISC 303 - Code of Standard Practice for Steel Buildings and Bridges.
  2. AISC 341 - Seismic Provisions for Structural Steel Buildings.
  3. AISC 360 - Specification for Structural Steel Buildings.
- B. American Society of Civil Engineers:
1. ASCE 19 - Standard Applications of Steel Cables for Buildings.
- C. ASTM International:
1. ASTM A36/A36M - Standard Specification for Carbon Structural Steel.
  2. ASTM A53/A53M - Standard Specification for Pipe, Steel, Black and Hot-Dipped, Zinc-Coated, Welded and Seamless.
  3. ASTM A108 - Standard Specification for Steel Bar, Carbon and Alloy, Cold-Finished.
  4. ASTM A123/A123M - Standard Specification for Zinc (Hot-Dip Galvanized) Coatings on Iron and Steel Products.
  5. ASTM A153/A153M - Standard Specification for Zinc Coating (Hot-Dip) on Iron and Steel Hardware.
  6. ASTM A193/A193M - Standard Specification for Alloy-Steel and Stainless Steel Bolting Materials for High-Temperature Service.
  7. ASTM A307 - Standard Specification for Carbon Steel Bolts and Studs, 60 000 PSI Tensile Strength.
  8. ASTM A325 - Standard Specification for Structural Bolts, Steel, Heat Treated, 120/105 ksi Minimum Tensile Strength.
  9. ASTM A354 - Standard Specification for Quenched and Tempered Alloy Steel Bolts, Studs, and Other Externally Threaded Fasteners.
  10. ASTM A449 - Standard Specification for Quenched and Tempered Steel Bolts and Studs.
  11. ASTM A490 - Standard Specification for Structural Bolts, Alloy Steel, Heat Treated, 150 ksi Minimum Tensile Strength.
  12. ASTM A500/A500M - Standard Specification for Cold-Formed Welded and Seamless Carbon Steel Structural Tubing in Rounds and Shapes.

13. ASTM A501 - Standard Specification for Hot-Formed Welded and Seamless Carbon Steel Structural Tubing.
14. ASTM A514/A514M - Standard Specification for High-Yield-Strength, Quenched and Tempered Alloy Steel Plate, Suitable for Welding.
15. ASTM A529/A529M - Standard Specification for High-Strength Carbon-Manganese Steel of Structural Quality.
16. ASTM A563 - Standard Specification for Carbon and Alloy Steel Nuts.
17. ASTM A572/A572M - Standard Specification for High-Strength Low-Alloy Columbium-Vanadium Structural Steel.
18. ASTM A588/A588M - Standard Specification for High-Strength Low-Alloy Structural Steel with 50 ksi (345 MPa) Minimum Yield Point to 4-in. (100-mm) Thick.
19. ASTM A618/A618M - Standard Specification for Hot-Formed Welded and Seamless High-Strength Low-Alloy Structural Tubing.
20. ASTM A786/A786M - Standard Specification for Hot-Rolled Carbon, Low-Alloy, High-Strength Low-Alloy, and Alloy Steel Floor Plates.
21. ASTM A847/A847M - Standard Specification for Cold-Formed Welded and Seamless High Strength, Low Alloy Structural Tubing with Improved Atmospheric Corrosion Resistance.
22. ASTM A852/A852M - Standard Specification for Quenched and Tempered Low-Alloy Structural Steel Plate with 70 ksi (485 MPa) Minimum Yield Strength to 4 in. (100 mm) Thick.
23. ASTM A913/A913M - Standard Specification for High-Strength Low-Alloy Steel Shapes of Structural Quality, Produced by Quenching and Self-Tempering Process (QST).
24. ASTM A992/A992M - Standard Specification for Structural Steel Shapes.
25. ASTM B695 - Standard Specification for Coatings of Zinc Mechanically Deposited on Iron and Steel.
26. ASTM E94 - Standard Guide for Radiographic Examination.
27. ASTM E164 - Standard Practice for Ultrasonic Contact Examination of Weldments.
28. ASTM E165 - Standard Test Method for Liquid Penetrant Examination.
29. ASTM E709 - Standard Guide for Magnetic Particle Examination.
30. ASTM F436 - Standard Specification for Hardened Steel Washers.
31. ASTM F959 - Standard Specification for Compressible-Washer-Type Direct Tension Indicators for Use with Structural Fasteners.
32. ASTM F1554 - Standard Specification for Anchor Bolts, Steel, 36, 55, and 105-ksi Yield Strength.
33. ASTM F1852 - Standard Specification for Twist Off Type Tension Control Structural Bolt/Nut/Washer Assemblies, Steel, Heat Treated, 120/105 ksi Minimum Tensile Strength.

D. American Welding Society:

1. AWS A2.4 - Standard Symbols for Welding, Brazing, and Nondestructive Examination.
2. AWS D1.1 - Structural Welding Code - Steel.

E. Research Council on Structural Connections:

1. RCSC - Specification for Structural Joints Using ASTM A325 or ASTM A490 Bolts.

F. SSPC: The Society for Protective Coatings:

1. SSPC - Steel Structures Painting Manual.
2. SSPC Paint 15 - Steel Joist Shop Paint.



3. SSPC Paint 20 - Zinc-Rich Primers (Type I - Inorganic and Type II - Organic).
4. SSPC SP 3 - Power Tool Cleaning.
5. SSPC SP 6 - Commercial Blast Cleaning.
6. SSPC SP 10 - Near-White Blast Cleaning.

### 1.3 SUBMITTALS

- A. Section 01300 - Submittal Procedures: Submittal Procedures.
- B. Shop Drawings:
  1. Indicate profiles, sizes, spacing, locations of structural members, openings, attachments, and fasteners.
  2. Connections
  3. Indicate welded connections with AWS A2.4 welding symbols. Indicate net weld lengths.
- C. Mill Test Reports: Submit indicating structural strength, destructive and non-destructive test analysis.
- D. Welders Certificates: Certify welders employed on the Work, verifying AWS qualification within previous 12 months.

### 1.4 QUALITY ASSURANCE

- A. Perform Work in accordance with the following:
  1. Structural Steel: AISC 303 and AISC 360.
  2. High Strength Bolted Connections: RCSC Specification for Structural Joints Using ASTM A 325 or A 490 Bolts.

### 1.5 QUALIFICATIONS

- A. Welders and Welding Procedures: AWS D1.1 qualified within previous 12 months.

### 1.6 COORDINATION

- A. Section 01040 - Project Coordination.
- B. Coordinate work with all other trades:

## PART 2 PRODUCTS

### 2.1 STRUCTURAL STEEL

- A. Structural W-Shapes: ASTM A992/A992M.
- B. Structural T-Shapes: Cut from structural W-shapes.
- C. Channels and Angles: ASTM A36/A36M
- D. Round Hollow Structural Sections: ASTM A500/A500M, Grade

1. Square and Rectangular Hollow Structural Sections: ASTM A500/A500M, Grade B
  - E. Structural Pipe: ASTM A53/A53M, Grade B
  - F. Structural Plates and Bars: ASTM A36/A36M
- 2.2 FASTENERS, CONNECTORS, AND ANCHORS
- A. High Strength Bolts: ASTM A325; Type 1
  - B. Nuts: ASTM A563 heavy hex type.
    1. Finish: Unfinished.
  - C. Washers: ASTM F436; Type 1, circular beveled
    1. Finish: Unfinished.
  - D. Tension Control Assemblies: ASTM F1852; Type 1, round head, twist off type; complete with washers and heavy hex nuts.
    1. Finish: Finish: Unfinished.
  - E. Anchor Rods: ASTM F1554; Grade 55,
    1. Plate Washers: ASTM A36/A36M.
  - F. Threaded Rods: ASTM A36/A36M
    1. Finish: Hot dipped galvanized
    2. Rod Ends, Yoke Ends and Pins, Cotter Pins, and Coupling Nuts: Carbon steel.
- 2.3 WELDING MATERIALS
- A. Welding Materials: AWS D1.1; type required for materials being welded.
- 2.4 ACCESSORIES
- A. Grout: Non-shrink type, pre-mixed compound consisting of non-metallic aggregate, cement, water reducing and plasticizing additives, capable of developing minimum compressive strength of 7,000 psi at 28 days.
  - B. Shop Primer: SSPC Paint 15, Type 1, red oxide.
  - C. Touch-Up Primer: Match shop primer.
- 2.5 FABRICATION
- A. Fabricate connections for bolt, nut, and washer connectors.
  - B. Develop required camber for members.
- 2.6 FINISH
- A. Shop prime structural steel members.

## 2.7 SOURCE QUALITY CONTROL AND TESTS

- A. Section 01400 - Quality Requirements: Testing and inspection services.
- B. Shop test bolted and welded connections as specified for field quality control tests.
- C. When fabricator is approved by authority having jurisdiction, submit certificate of compliance indicating Work performed at fabricator's facility conforms to Contract Documents.
  - 1. Specified shop tests are not required for Work performed by approved fabricator.

## PART 3 EXECUTION

### 3.1 EXAMINATION

- A. Section 01400 – Project Coordination.
- B. Verify bearing surfaces are at correct elevation.
- C. Verify anchors rods are set in correct locations and arrangements with correct exposure for steel attachment.

### 3.2 PREPARATION

- A. Furnish templates for installation of anchor rods and embedments in concrete and masonry work.

### 3.3 ERECTION

- A. Allow for erection loads, and for sufficient temporary bracing to maintain structure safe, plumb, and in alignment until completion of erection and installation of permanent bracing.
- B. Field weld components indicated on Drawings.
- C. Field connect members with threaded fasteners; torque to required resistance
- D. Do not field cut or alter structural members without approval of Architect/Engineer.

### 3.4 GROUT INSTALLATION

- A. Shim bearing plates and equipment supports to proper elevation, snug tighten anchor bolts.
- B. Fill void under bearing surface with grout. Install and pack grout to remove air pockets.
- C. Moist cure grout.
- D. Remove forms after grout is set. Trim grout edges to from smooth surface, splayed 45 degrees.
- E. Tighten anchor bolts after grout has cured for a minimum of 3 days.

3.5 ERECTION TOLERANCES

- A. Section 01400 - Quality Requirements: Tolerances.

3.6 FIELD QUALITY CONTROL

- A. Section 01400 - Quality Requirements: Testing and inspection services.
- B. Bolted Connections: Inspect in accordance with AISC 303.
1. Visually inspect all bolted connections.
  2. For Direct Tension Indicators, comply with requirements of ASTM F959. Verify that gaps are less than gaps specified in Table 2.
- C. Welding: Inspect welds in accordance with AWS D1.1.
1. Certify welders and conduct inspections and tests as required. Record types and locations of defects found in work. Record work required and performed to correct deficiencies.
  2. Visually inspect all welds.
  3. Ultrasonic Inspection: ASTM E164; perform on all full penetration welds.
  4. Liquid Penetrant Inspection: ASTM E165.
- D. Correct defective bolted connections and welds.

END OF SECTION

SECTION 05 50 00

METAL FABRICATIONS

PART 1 GENERAL

1.1 SUMMARY

- A. Section includes shop fabricated metal items.
  - 1. Lintels.
  - 2. Structural supports for miscellaneous attachments.
  - 3. Custom stainless steel fabrications.
- B. Related Sections:
  - 1. Section 05 12 00 - Structural Steel Framing.
  - 2. Section 07 90 00 – Joint Protection: Sealants

1.2 REFERENCES

- A. Aluminum Association:
  - 1. AA DAF-45 - Designation System for Aluminum Finishes.
- B. American Architectural Manufacturers Association:
  - 1. AAMA 611 - Voluntary Specification for Anodized Architectural Aluminum.
  - 2. AAMA 2603 - Voluntary Specification, Performance Requirements and Test Procedures for Pigmented Organic Coatings on Aluminum Extrusions and Panels.
  - 3. AAMA 2604 - Voluntary specification, Performance Requirements and Test Procedures for High Performance Organic Coatings on Aluminum Extrusions and Panels.
  - 4. AAMA 2605 - Voluntary Specification, Performance Requirements and Test Procedures for Superior Performing Organic Coatings on Aluminum Extrusions and Panels.
- C. ASTM International:
  - 1. ASTM A36/A36M - Standard Specification for Carbon Structural Steel.
  - 2. ASTM A123/A123M - Standard Specification for Zinc (Hot-Dip Galvanized) Coatings on Iron and Steel Products.
  - 3. ASTM A276 - Standard Specification for Stainless Steel Bars and Shapes.
  - 4. ASTM A354 - Standard Specification for Quenched and Tempered Alloy Steel Bolts, Studs, and Other Externally Threaded Fasteners.
  - 5. ASTM A554 - Standard Specification for Welded Stainless Steel Mechanical Tubing.
- D. American Welding Society:
  - 1. AWS A2.4 - Standard Symbols for Welding, Brazing, and Nondestructive Examination.
  - 2. AWS D1.1 - Structural Welding Code - Steel.
  - 3. AWS D1.6 - Structural Welding Code - Stainless Steel.

- E. National Ornamental & Miscellaneous Metals Association:
  - 1. NOMMA Guideline 1 - Joint Finishes.

### 1.3 SUBMITTALS

- A. Section 01300 - Submittals: Submittal requirements.
- B. Shop Drawings: Indicate profiles, sizes, connection attachments, reinforcing, anchorage, size and type of fasteners, and accessories. Include erection drawings, elevations, and details where applicable. Indicate welded connections using standard AWS A2.0 welding symbols. Indicate net weld lengths.
- C. Samples: Submit two stainless steel sheets 6 x 6 inch in size illustrating factory finishes.
- D. Welders Certificates: Certify welders employed on the Work, verifying AWS qualification within previous 12 months.

### 1.4 QUALITY ASSURANCE

- A. Finish joints in accordance with NOMMA Guideline 1.
- B. Maintain one copy of each document on site.

### 1.5 MOCKUP

- A. Section 1400 - Quality Requirements: Mockup requirements.
- B. Construct mock-up, sample stainless steel enclosure, diameter shown on drawing x 4' high, including base inset detail and client.
- C. Locate where directed by Architect/Engineer.
- D. Remove mockup when directed by Architect/Engineer.

### 1.6 DELIVERY, STORAGE, AND HANDLING

- A. Section 01630 - Product Requirements: Product storage and handling requirements.
- B. Accept metal fabrications on site in labeled shipments. Inspect for damage.
- C. Protect metal fabrications from damage by exposure to weather.

### 1.7 FIELD MEASUREMENTS

- A. Verify field measurements are as indicated on shop drawings.

## PART 2 PRODUCTS

### 2.1 MATERIALS - STEEL

- A. Steel Sections: ASTM A36/A36.
- B. Steel Plate: ASTM A36/A36M.
- C. Hollow Structural Sections: ASTM A500, Grade B.
- D. Steel Pipe: ASTM A53, Grade B Schedule 40.
- E. Sheet Steel: ASTM A653, Grade 33 Structural Quality with galvanized coating.
- F. Bolts: ASTM A307; Grade A or B.
  - 1. Finish: Hot dipped galvanized. Mechanically galvanized.
- G. Nuts: ASTM A563 heavy hex type.
  - 1. Finish: Hot dipped galvanized.
- H. Washers: ASTM F436; Type 1.
  - 1. Finish: Unfinished. Hot dipped galvanized.
- I. Welding Materials: AWS D1.1; type required for materials being welded.
- J. Shop Primer: SSPC Paint 15, Type 1, red oxide.
- K. Touch-Up Primer: Match shop primer.
  - 1. Interior Anti-Corrosive Paints: Maximum volatile organic compound content in accordance with GC-03.

### 2.2 MATERIALS - STAINLESS STEEL

- A. Plate, Sheet and Strip: ASTM A167; Type 316 16 gauge.
- B. Bolts, Nuts, and Washers: ASTM A354.
- C. Welding Materials: AWS D1.6; type required for materials being welded.

### 2.3 LINTELS

- A. Lintels: Steel sections, size and configuration as indicated on Drawings, length to allow 8 inches minimum bearing on both sides of opening.
  - 1. Exterior Locations: Galvanized.

### 2.4 FABRICATION

- A. Fit and shop assemble items in largest practical sections, for delivery to site.
- B. Fabricate items with joints tightly fitted and secured.

- C. Continuously seal joined members by continuous welds.
- D. Exposed Welded Joints: NOMMA Guideline 1 Joint Finish #1.
- E. Exposed Mechanical Fastenings: Flush countersunk screws or bolts; unobtrusively located; consistent with design of component, except where specifically noted otherwise.
- F. Supply components required for anchorage of fabrications. Fabricate anchors and related components of same material and finish as fabrication, except where specifically noted otherwise.

## 2.5 FACTORY APPLIED FINISHES - STEEL

- A. Prime paint items with two coats except where galvanizing is specified.

## 2.6 FACTORY APPLIED FINISHES - STAINLESS STEEL

- A. Satin Polished Finish: Number 4, satin directional polish parallel with long dimension of finished face.

## 2.7 FABRICATION TOLERANCES

- A. Squareness: 1/8 inch maximum difference in diagonal measurements.
- B. Maximum Offset Between Faces: 1/16 inch.
- C. Maximum Misalignment of Adjacent Members: 1/16 inch.
- D. Maximum Bow: 1/16 inch in 48 inches.
- E. Maximum Deviation From Plane: 1/16 inch in 48 inches.

## PART 3 EXECUTION

### 3.1 EXAMINATION

- A. Section 01040 – Project Coordination: Coordination and project conditions.
- B. Verify field conditions are acceptable and are ready to receive Work.

### 3.2 PREPARATION

- A. Clean and strip primed steel items to bare metal and aluminum where site welding is required.
- B. Supply steel items required to be cast into concrete or embedded in masonry with setting templates to appropriate sections.



3.3 INSTALLATION

- A. Install items plumb and level, accurately fitted, free from distortion or defects.
- B. Make provisions for erection stresses. Install temporary bracing to maintain alignment, until permanent bracing and attachments are installed.
- C. Obtain approval of Architect/Engineer prior to site cutting or making adjustments not scheduled.

END OF SECTION

SECTION 07 84 00

FIRESTOPPING

PART 1 GENERAL

1.1 SUMMARY

A. Section Includes:

1. Firestopping through-penetrations of fire rated assemblies.
2. Firestopping joints in fire rated assemblies.
3. Firestopping tops of fire rated walls.
4. Smoke and vapor sealing penetrations and joints of smoke and vapor partitions.

B. Related Sections:

1. Section 04 05 03 - Masonry Mortaring and Grouting: Mortar used for firestopping.
2. Section 09 21 16 - Gypsum Board Assemblies: Gypsum board fireproofing.

1.2 REFERENCES

A. ASTM International:

1. ASTM E84 - Standard Test Method for Surface Burning Characteristics of Building Materials.
2. ASTM E119 - Standard Test Methods for Fire Tests of Building Construction and Materials.
3. ASTM E814 - Standard Test Method for Fire Tests of Through-Penetration Fire Stops.
4. ASTM E1966 - Standard Test Method for Fire-Resistive Joint Systems.

B. Intertek Testing Services (Warnock Hersey Listed):

1. WH - Certification Listings.

C. Underwriters Laboratories Inc.:

1. UL 263 - Fire Tests of Building Construction and Materials.
2. UL 1479 - Fire Tests of Through-Penetration Firestops.
3. UL 2079 - Tests for Fire Resistance of Building Joint Systems.
4. UL - Fire Resistance Directory.

1.3 DEFINITIONS

- A. Firestopping (Through-Penetration Protection System): Sealing or stuffing material or assembly placed in spaces between and penetrations through building materials to arrest movement of fire, smoke, heat, and hot gases through fire rated construction.

1.4 PERFORMANCE REQUIREMENTS

- A. Conform to IBC, FM, UL, and WH for fire resistance ratings and surface burning characteristics.
- B. Provide certificate of compliance from authority having jurisdiction indicating approval of materials used.

## 1.5 SUBMITTALS

- A. Section 01300 Submittals.
- B. Product Data: Submit data on product characteristics, performance and limitation criteria.
- C. Schedule: Submit schedule of opening locations and sizes, penetrating items, and required listed design numbers to seal openings to maintain fire resistance rating of adjacent assembly.
- D. Manufacturer's Installation Instructions: Submit preparation and installation instructions.
- E. Manufacturer's Certificate: Certify products meet or exceed applicable code requirements.
- F. Engineering Judgements: For conditions not covered by UL or WH listed designs, submit judgements by licensed professional engineer suitable for presentation to authority having jurisdiction for acceptance as meeting code fire protection requirements.

## 1.6 QUALITY ASSURANCE

- A. Through Penetration Firestopping of Fire Rated Assemblies: UL 1479 or ASTM E814 with 0.10 inch water gage minimum positive pressure differential to achieve fire F-Ratings and temperature T-Ratings as indicated on Drawings, but not less than 1-hour.
  - 1. Wall Penetrations: Fire F-Ratings as indicated on Drawings, but not less than 1-hour.
- B. Fire Resistant Joints in Fire Rated Floor, Roof, and Wall Assemblies: ASTM E1966 or UL 2079 to achieve fire resistant rating as indicated on Drawings for assembly in which joint is installed.
  - 1. Smoke Barrier Joints Air Leakage: Maximum 5 cfm per foot 0.30 inches water gage pressure differential
- C. Surface Burning Characteristics: Maximum 25/450 flame spread/smoke developed index when tested in accordance with ASTM E84.

## 1.7 QUALIFICATIONS

- A. Manufacturer: Company specializing in manufacturing products specified in this section with minimum three years documented experience.
- B. Applicator: Company specializing in performing Work of this section with minimum three years documented experience, and approved by manufacturer.

## 1.8 ENVIRONMENTAL REQUIREMENTS

- A. Section 01630 – Product Requirements and Substitutions.
- B. Do not apply materials when temperature of substrate material and ambient air is below 60 degrees F.
- C. Maintain this minimum temperature before, during, and for minimum 3 days after installation of materials.

- D. Provide ventilation in areas to receive solvent cured materials.

## PART 2 PRODUCTS

### 2.1 FIRESTOPPING

A. Manufacturers:

1. A/D Fire Protection Systems, Inc.
2. Hilti Corp.
3. 3M Fire Protection Products
4. Nelson Firestop Products
5. Specified Technologies
6. United States Gypsum Co.
7. Substitutions: Section 01630 – Product Requirements and Substitutions.

B. Product Description: Different types of products by multiple manufacturers are acceptable as required to meet specified system description and performance requirements; provide only one type for each similar application.

1. Silicone Firestopping Elastomeric Firestopping: Single component silicone elastomeric compound and compatible silicone sealant.
  - a. Interior Sealants and Sealant Primers: Maximum volatile organic compound content in accordance with SCAQMD Rule 1168.
2. Foam Firestopping Compounds: Multiple component foam compound.
3. Formulated Firestopping Compound of Incombustible Fibers: Formulated compound mixed with incombustible non-asbestos fibers.
4. Fiber Stuffing and Sealant Firestopping: Composite of mineral fiber stuffing insulation with silicone elastomer for smoke stopping.
5. Mechanical Firestopping Device with Fillers: Mechanical device with incombustible fillers and silicone elastomer, covered with sheet stainless steel jacket, joined with collars, penetration sealed with flanged stops.
6. Intumescent Firestopping: Intumescent putty compound which expands on exposure to surface heat gain.
7. Firestop Pillows: Formed mineral fiber pillows.
8. Mortar as specified in Section 04 05 03 where permitted by applicable code.

### 2.2 ACCESSORIES

- A. Primer: Type recommended by firestopping manufacturer for specific substrate surfaces and suitable for required fire ratings.
- B. Installation Accessories: Provide clips, collars, fasteners, temporary stops or dams, and other devices required to position and retain materials in place.

## PART 3 EXECUTION

### 3.1 EXAMINATION

- A. Section 01040 – Project Coordination.
- B. Verify openings are ready to receive firestopping.

### 3.2 PREPARATION

- A. Clean substrate surfaces of dirt, dust, grease, oil, loose material, or other matter affecting bond of firestopping material.
- B. Remove incompatible materials affecting bond.
- C. Install damming materials to arrest liquid material leakage.

### 3.3 APPLICATION

- A. Install material at fire rated construction perimeters and openings containing penetrating sleeves, piping, ductwork, conduit and other items, requiring firestopping.
- B. Apply primer where recommended by manufacturer for type of firestopping material and substrate involved, and as required for compliance with required fire ratings.
- C. Apply firestopping material in sufficient thickness to achieve required fire and smoke rating, to uniform density and texture.
- D. Compress fibered material to maximum 40 percent of its uncompressed size.
- E. Place foamed material in layers to ensure homogenous density, filling cavities and spaces. Place sealant to completely seal junctions with adjacent dissimilar materials.
- F. Remove dam material after firestopping material has cured.

### 3.4 FIELD QUALITY CONTROL

- A. Section 01400 – Quality Requirements and Section 01780 – Contract Closeout.
- B. Inspect installed firestopping for compliance with specifications and submitted schedule.

### 3.5 CLEANING

- A. Section 01780 – Contract Closeout.
- B. Clean adjacent surfaces of firestopping materials.

### 3.6 PROTECTION OF INSTALLED CONSTRUCTION

- A. Section 01780 – Contract Closeout.

- B. Protect adjacent surfaces from damage by material installation.

END OF SECTION

SECTION 23 05 13

COMMON MOTOR REQUIREMENTS FOR HVAC EQUIPMENT

PART 1 GENERAL

1.1 SUMMARY

- A. Section includes single- and three-phase motors for application on equipment provided under other sections and for motors furnished loose to Project.
- B. Related Sections:
  - 1. Section 26 05 53 - Identification for Electrical Systems.

1.2 REFERENCES

- A. American Bearing Manufacturers Association:
  - 1. ABMA 9 - Load Ratings and Fatigue Life for Ball Bearings.
- B. National Electrical Manufacturers Association:
  - 1. NEMA MG 1 - Motors and Generators.
- C. International Electrical Testing Association:
  - 1. NETA ATS - Acceptance Testing Specifications for Electrical Power Distribution Equipment and Systems.

1.3 SUBMITTALS

- A. Section 01300 - Submittals: Submittal procedures.
- B. Product Data: Submit catalog data for each motor furnished loose. Indicate nameplate data, standard compliance, electrical ratings and characteristics, and physical dimensions, weights, mechanical performance data, and support points.
- C. Test Reports: Indicate procedures and results for specified factory and field testing and inspection.

1.4 QUALIFICATIONS

- A. Manufacturer: Company specializing in manufacturing products specified in this section with minimum three years experience.
- B. Testing Agency: Company member of International Electrical Testing Association and specializing in testing products specified in this section with minimum three years documented experience.

## 1.5 DELIVERY, STORAGE, AND HANDLING

- A. Section 01630 - Product Requirements: Product storage and handling requirements.
- B. Lift only with lugs provided. Handle carefully to avoid damage to components, enclosure, and finish.
- C. Protect products from weather and moisture by covering with plastic or canvas and by maintaining heating within enclosure.
- D. For extended outdoor storage, remove motors from equipment and store separately.

## PART 2 PRODUCTS

### 2.1 PRODUCT REQUIREMENTS FOR MOTORS

- A. General:
  - 1. Acceptable Manufacturers:
    - a. U.S. Motor.
    - b. Reliance Electric.
    - c. Baldor.
    - d. Marathon.
    - e. Substitutions: Section 01630 - Product Requirements.
  - 2. Motors 1/2 hp and Larger: Three-phase motor as specified below.
  - 3. Motors Smaller Than 1/2 hp: Single-phase motor as specified below, except motors less than 250 watts or 1/4 hp may be equipment manufacturer's standard.
  - 4. Service factor: 1.15
  - 5. Efficiency: Premium efficiency design.
  - 6. Motors on driven equipment: Torque characteristics and speed specified shall be the responsibility of the driven equipment vendor. Motors shall be matched to and submitted with the driven equipment.
  - 7. Motor Duty: Continuous-duty operation unless otherwise noted.
  - 8. Motor speed/torque: NEMA Design B unless otherwise noted. Motors shall exceed the speed-torque requirements of the driven equipment over its entire operating range by at least 10% at the rated voltage.
  - 9. Starting: Motors shall be designed for full-voltage starting.
    - a. Motors shall be able to overcome starting load inertia as well as accelerating the load to rated speed under both rated and reduced (905) voltage conditions during starting without injurious heating.
    - b. Unless otherwise specified, motors shall be designed for across-the-line starting and for the minimum number of consecutive starts from rest with the initial temperature of windings at 40 deg C ambient level, per NEMA MG-1.
  - 10. All motors are for coupled or belted service unless otherwise indicated.
  - 11. Temperature rise of motors shall be limited to Class B rise.
  - 12. All electric motors supplied in accordance with their specification shall meet the requirements of the area classification in which it is to be installed as defined by National Electrical Code, latest edition.



13. Wiring Terminations: Furnish terminal lugs to match branch circuit conductor quantities, sizes, and materials indicated.
- B. Construction:
1. Fans: Suitable for rotation in either direction. Fans shall be of non-sparking, corrosion resistant material, accurately balanced before assembly on rotor. Plastic, fiberglass, or other nonmetallic fan housings are not acceptable.
  2. Screens or louvers shall be provided on drip-proof and weatherproof enclosures and shall be constructed of corrosion resistant material.
  3. All motors shall be equipped with a grounding lug on the motor frame on same side as main terminal box.
  4. Sound power levels shall be in accordance with the requirements of NEMA MG-1.
  5. Motor Frame: TEFC construction in wet areas (including boiler rooms and air compressor rooms). Open-Drip-Proof in dry areas. TENV with powder coated or stainless steel exterior for wet areas. All frames, fan covers, and terminal boxes on NEMA frame motors shall be cast iron.
  6. Motor Junction Boxes
    - a. Adequately sized to accommodate the cable types and devices specified on the individual motor data sheet. For motors 4 kV and above: boxes shall be adequately sized for making up stress cones on shielded cable.
  7. Main motor lead junction box:
    - a. Cast iron or fabricated steel not less than 1/8 inch in thickness.
    - b. Heavy-duty class, weather-tight or explosion-proof as specified on the individual motor data sheet.
    - c. Boxes shall be able to be rotated in 90 degree increments.
  8. Protective equipment boxes for RTD leads, heater leads, etc.
    - a. Cast iron or fabricated steel not less than 1/8 inch in thickness.
    - b. Heavy-duty class, weather-tight or explosion-proof as specified on the individual motor data sheet.
    - c. Boxes shall be able to be rotated in 90 degree increments.
  9. All motor terminal and protective equipment boxes shall be thoroughly coated internally and externally with corrosion-resistant paint. Match paint of motor frame.
  10. Insulation Systems
    - a. Minimum Class F, or better, insulation system for stators and rotors.
    - b. Insulation system: Sealed, consisting of a complete encapsulation with an epoxy resin-mica compound impervious to moisture.
  11. Bearings
    - a. Anti-friction bearings shall be in accordance with the Anti-friction Bearing Manufacturer's Association Standards.
    - b. Bearings shall have an L-10 rating of 50,000 hours belted and 150,000 hours direct coupled.
    - c. Bearing life shall be based on continuous operation with maximum radial and axial loads in any direction.
- C. VFD Rated Motors
1. Shall meet the requirements of NEMA MG-1, Part 31.
  2. Shall have 1600 volt rated insulation.
  3. Bearings: Insulated to prevent pitting.

- D. Horizontal and Vertical In-Line Motors through 200 HP
  - 1. All bearings for horizontal and vertical in-line motors shall be designed for 2 years, B-10, minimum life in the specified services as defined by AFBMA Standards.
  
- E. Horizontal Motors Above 200 HP
  - 1. Oil lubricated sleeve bearings with reservoirs of generous capacity effectively covered so no dust or other foreign materials can enter the bearing.
  - 2. Oil slingers and catchers shall be designed to prevent the escape of oil from bearing and creepage along the shaft.
  - 3. Reservoirs shall be provided with gauge glasses. A permanent oil level indicator shall be provided.
  - 4. Sleeve bearing motors shall have a shaft end float of 1/2 inch minimum.
  
- F. Vertical Motors
  - 1. Thrust bearings shall be LP rated per API 610 for pumps and similar applications.
  
- G. Balancing and Vibration
  - 1. Motors shall be dynamically balanced.
  - 2. No solder or similar balancing deposits are acceptable.
  - 3. Parent metal removed to effect the balance shall be removed so as not to affect the structural strength or rotating equipment.
  - 4. The maximum vibration:
    - a. Amplitude (peak-to-peak) as measured on the rotor shaft shall not exceed 0.0015 inches for 1,800 rpm machines and 0.001 inches for 3,600 rpm machines.
    - b. For vibration measurements, motors shall be operated at rated speed and frequency and with one-half of a standard key in the key seat.
    - c. Motor shall be mounted on isolators in accordance with NEMA MG-a-12.06, paragraph A.

## 2.2 SOURCE QUALITY CONTROL

- A. Test motors in accordance with NEMA MG 1, including winding resistance, no-load speed and current, locked rotor current, insulation high-potential test, and mechanical bearing and alignment tests.

## PART 3 EXECUTION

### 3.1 EXISTING WORK

- A. Disconnect and remove abandoned motors

- B. Maintain access to existing motors and other installations remaining active and requiring access. Modify installation or provide access panel.

3.2 INSTALLATION

- A. Install securely on firm foundation.
- B. Install engraved plastic nameplates in accordance with Section 26 05 53.
- C. Ground and bond motors in accordance with Section 26 05 26.

3.3 FIELD QUALITY CONTROL

- A. Section 01780 - Project Closeout: Field inspecting, testing, adjusting, and balancing.
- B. Field test with the driver equipment during start-up and commissioning.

END OF SECTION

SECTION 23 05 23

GENERAL DUTY VALVES AND ACCESSORIES

PART 1 GENERAL

1.1 SUMMARY

- A. Section Includes:
  - 1. Gate valves.
  - 2. Ball valves.
  - 3. Butterfly valves.
  - 4. Check valves.
  - 5. See valve specification schedules on the project drawing.
  
- B. Related Sections:
  - 1. Section 23 05 29 - Hangers and Supports for Piping and Equipment.
  - 2. Section 23 05 53 – Mechanical Identification for Piping and Equipment.
  - 3. Section 23 07 00 – Mechanical Insulation.
  - 4. Section 23 21 13 - Hydronic Piping.
  - 5. Section 23 21 16 - Hydronic Piping Specialties.
  - 6. Section 23 22 13 - Steam and Condensate Heating Piping.
  - 7. Section 23 22 16 - Steam and Condensate Piping Specialties.

1.2 REFERENCES

- A. ASTM International:
  - 1. ASTM A216/A216M - Standard Specification for Steel Castings, Carbon, Suitable for Fusion Welding, for High-Temperature Service.
  - 2. ASTM D1784 - Standard Specification for Rigid Poly (Vinyl Chloride) (PVC) Compounds and Chlorinated Poly (Vinyl Chloride) (CPVC) Compounds.
  
- B. Manufacturers Standardization Society of the Valve and Fittings Industry:
  - 1. MSS SP 67 - Butterfly Valves.
  - 2. MSS SP 70 - Cast Iron Gate Valves, Flanged and Threaded Ends.
  - 3. MSS SP 71 - Cast Iron Swing Check Valves, Flanged and Threaded Ends.
  - 4. MSS SP 78 - Cast Iron Plug Valves, Flanged and Threaded Ends.
  - 5. MSS SP 80 - Bronze Gate, Globe, Angle and Check Valves.
  - 6. MSS SP 85 - Cast Iron Globe & Angle Valves, Flanged and Threaded.
  - 7. MSS SP 110 - Ball Valves Threaded, Socket-Welding, Solder Joint, Grooved and Flared Ends.
  
- C. Underwriters Laboratories Inc.:
  - 1. UL 842 - Valves for Flammable Fluids.

1.3 SUBMITTALS

- A. Section 01300 - Submittals: Submittals Procedure.

- B. Product Data: Submit manufacturers catalog information with valve data and ratings for each service. Clearly indicate make, model, type, size, location and utility service.
- C. Manufacturer's Installation Instructions: Submit hanging and support methods, joining procedures.
- D. Manufacturer's Certificate: Certify products meet or exceed specified requirements.

#### 1.4 CLOSEOUT SUBMITTALS

- A. Section 01780 - Contract Closeout: Requirements for submittals.
- B. Project Record Documents: Record actual locations of valves on as-built drawings.
- C. Operation and Maintenance Data: Submit installation instructions, spare parts lists, exploded assembly views.

#### 1.5 QUALITY ASSURANCE

- A. Perform Work in accordance with State, Local, and National Codes, Standards, and Regulations.
- B. Maintain one copy copies of each document on site.

#### 1.6 QUALIFICATIONS

- A. Manufacturer: Company specializing in manufacturing Products specified in this section with minimum three years documented experience.
- B. Installer: Company specializing in performing work of this section with minimum 3 years documented experience and/or approved by manufacturer.

#### 1.7 PRE-INSTALLATION MEETINGS

- A. Section 01040 – Project Coordination: Construction Coordination.
- B. Convene minimum one week prior to commencing work of this section.

#### 1.8 DELIVERY, STORAGE, AND HANDLING

- A. Section 01630 - Product Requirements: Requirements for transporting, handling, storing, and protecting products.
- B. Accept valves on site in shipping containers with labeling in place. Inspect for damage.
- C. Provide temporary protective coating on cast iron and steel valves.

#### 1.9 ENVIRONMENTAL REQUIREMENTS

- A. Do not install valves underground when bedding is wet or frozen.

1.10 WARRANTY

- A. Section 01780 – Contract Closeout: Requirements for Warranties and Bonds.
- B. Furnish five year manufacturer warranty for valves excluding packing.

1.11 EXTRA MATERIALS

- A. Section 01780 – Contract Closeout: Spare Parts and Extra Quantities
- B. Furnish two packing kits for each size valve.

PART 2 PRODUCTS

2.1 GENERAL

- A. Provide valves of same manufacturer throughout, where possible.
- B. Types of valves and manufacturers should be as noted on the schedule. See valve specifications schedules on the project drawing.

PART 3 EXECUTION

3.1 EXAMINATION

- A. Verify piping system is ready for valve installation.

3.2 INSTALLATION

- A. Install valves with stems upright or horizontal, not inverted.
- B. Install 3/4 inch gate or ball valves with cap for drains at main shut-off valves, low points of piping, bases of vertical risers, and at equipment.
- C. Install valves with clearance for installation of insulation and allowing access.
- D. All valves shall be installed in a manner that makes them fully accessible for operation and maintenance.
- E. Refer to Section 23 05 29 for pipe hangers.
- F. Refer to Section 23 07 00 for insulation requirements for valves.
- G. For installation of valves in steam and steam condensate piping systems refer to Section 23 22 13.
- H. Refer to Section 23 05 53 for valve tags.

- I. Install valves where shown on drawings. Full size of pipe unless otherwise indicated. Provide neat appearance and easy grouping with all parts easily accessible. Valve stems shall be installed in the horizontal or upright position.
- J. Contractor shall install all valves in accordance with manufacturer's installation recommendations.
- K. Unless otherwise noted, valves 4" and larger are supplied with gear operators that are to be field oriented by the contractor to facilitate ease of operation and maintenance. Owner's representative may have the contractor alter the valve operator orientations at no extra cost to owner.
- L. Valve Directory: Submit in duplicate for review, a listing of all numbered valves, size, location, normal position and function. After acceptance, put copy in each maintenance manual.
- M. Unions: Install unions in all non-flanged pipe connections to apparatus and adjacent to all screwed control valves, traps, and appurtenances required access for maintenance.
- N. Provide isolation valves on main branches, connections to equipment, and at control valves.
- O. Provide blow-off valves on strainers.

END OF SECTION

SECTION 23 05 29

HANGERS AND SUPPORTS FOR PIPING AND EQUIPMENT

PART 1 GENERAL

1.1 SUMMARY

- A. Section Includes:
  - 1. Pipe hangers and supports.
  - 2. Hanger rods.
  - 3. Flashing.
  - 4. Sleeves.
  - 5. Mechanical sleeve seals.
  - 6. Formed steel channel.
  - 7. Firestopping relating to HVAC work.
  - 8. Firestopping accessories.
  - 9. Equipment bases and supports.
  - 10. Existing pipe supports shall be re-designed for new pipe and remaining loads.
  - 11. New supports shall be designed and provided when installing new pipes.
  
- B. Related Sections:
  - 1. Section 23 21 13 - Hydronic Piping.
  - 2. Section 23 22 13 - Steam and Condensate Heating Piping.

1.2 REFERENCES

- A. American Society of Mechanical Engineers:
  - 1. ASME B31.1 - Power Piping.
  - 2. ASME B31.9 - Building Services Piping.
  
- B. ASTM International:
  - 1. ASTM E84 - Test Method for Surface Burning Characteristics of Building Materials.
  - 2. ASTM E814 - Test Method of Fire Tests of Through Penetration Firestops.
  - 3. ASTM F708 - Standard Practice for Design and Installation of Rigid Pipe Hangers.
  
- C. American Welding Society:
  - 1. AWS D1.1 - Structural Welding Code - Steel.
  
- D. FM Global:
  - 1. FM - Approval Guide, A Guide to Equipment, Materials & Services Approved By Factory Mutual Research For Property Conservation.
  
- E. Manufacturers Standardization Society of the Valve and Fittings Industry:
  - 1. MSS SP 58 - Pipe Hangers and Supports - Materials, Design and Manufacturer.
  - 2. MSS SP 69 - Pipe Hangers and Supports - Selection and Application.
  - 3. MSS SP 89 - Pipe Hangers and Supports - Fabrication and Installation Practices.



- F. Underwriters Laboratories Inc.:
  - 1. UL 1479 - Fire Tests of Through-Penetration Firestops.
  - 2. UL 2079 - Tests for Fire Resistance of Building Joint Systems.
  - 3. UL - Fire Resistance Directory.

### 1.3 DEFINITIONS

- A. Firestopping (Through-Penetration Protection System): Sealing or stuffing material or assembly placed in spaces between and penetrations through building materials to arrest movement of fire, smoke, heat, and hot gases through fire rated construction.

### 1.4 SYSTEM DESCRIPTION

- A. Firestopping Materials: ASTM E119, ASTM E814, UL 263 or UL 1479 to achieve fire ratings as noted on Drawings for adjacent construction, but not less than 1 hour fire rating.
  - 1. Ratings may be 3-hours for firestopping in through-penetrations of 4-hour fire rated assemblies unless otherwise required by applicable codes.
- B. Surface Burning: ASTM E84 or UL 723 with maximum flame spread / smoke developed rating of 25/450.
- C. Firestop interruptions to fire rated assemblies, materials, and components.

### 1.5 PERFORMANCE REQUIREMENTS

- A. Firestopping: Provide certificate of compliance from authority having jurisdiction indicating approval of materials used.

### 1.6 SUBMITTALS

- A. Section 01300 - Submittals: Submittals procedures.
- B. Shop Drawings: Indicate system layout with location including critical dimensions, sizes, and pipe hanger and support locations and detail of trapeze hangers.
- C. Product Data:
  - 1. Hangers and Supports: Submit manufacturers catalog data including load capacity.
  - 2. Firestopping: Submit data on product characteristics, performance and limitation criteria.
  - 3. Sleeves.
  - 4. Anchors and Anchorage.
  - 5. Flashing.
- D. Firestopping Schedule: Submit schedule of opening locations and sizes, penetrating items, and required listed design numbers to seal openings to maintain fire resistance rating of adjacent assembly.
- E. Manufacturer's Installation Instructions:

1. Hangers and Supports: Submit special procedures and assembly of components.
2. Firestopping: Submit preparation and installation instructions.

F. Manufacturer's Certificate: Certify products meet or exceed specified requirements.

#### 1.7 QUALITY ASSURANCE

- A. Through Penetration Firestopping of Fire Rated Assemblies: UL 1479 or ASTM E814 with 0.10 inch water gage minimum positive pressure differential to achieve fire F-Ratings and temperature T-Ratings as indicated on Drawings, but not less than 1-hour.
1. Wall Penetrations: Fire F-Ratings as indicated on Drawings, but not less than 1-hour.
  2. Floor and Roof Penetrations: Fire F-Ratings and temperature T-Ratings as indicated on Drawings, but not less than 1-hour.
    - a. Floor Penetrations Within Wall Cavities: T-Rating is not required.
- B. Through Penetration Firestopping of Non-Fire Rated Floor and Roof Assemblies: Materials to resist free passage of flame and products of combustion.
1. Noncombustible Penetrating Items: Noncombustible materials for penetrating items connecting maximum of three stories.
  2. Penetrating Items: Materials approved by authorities having jurisdiction for penetrating items connecting maximum of two stories.
- C. Surface Burning Characteristics: 25/450 flame spread/smoke developed index when tested in accordance with ASTM E84.
- D. Perform Work in accordance with applicable authority for welding hanger and support attachments to building structure.
- E. Perform Work in accordance with local and national codes, standards and regulations.

#### 1.8 QUALIFICATIONS

- A. Manufacturer: Company specializing in manufacturing Products specified in this section with minimum three years documented experience.
- B. Installer: Company specializing in performing Work of this section with minimum three years documented experience and/or approved by manufacturer.

#### 1.9 PRE-INSTALLATION MEETINGS

- A. Section 01040 – Project Coordination: Construction Coordination.
- B. Convene minimum one week prior to commencing work of this section.

#### 1.10 DELIVERY, STORAGE, AND HANDLING

- A. Section 01630 - Product Requirements: Requirements for transporting, handling, storing, and protecting products.

- B. Accept materials on site in original factory packaging, labeled with manufacturer's identification.
- C. Protect from weather and construction traffic, dirt, water, chemical, and damage, by storing in original packaging.

#### 1.11 ENVIRONMENTAL REQUIREMENTS

- A. Do not apply firestopping materials when temperature of substrate material and ambient air is below 60 degrees F.
- B. Maintain this minimum temperature before, during, and for minimum 3 days after installation of firestopping materials.

#### 1.12 FIELD MEASUREMENTS

- A. Verify field measurements prior to fabrication.

#### 1.13 WARRANTY

- A. Section 01780 - Contract Closeout: Warranties and Bonds.
- B. Furnish five year manufacturer warranty for pipe hangers and supports.

### PART 2 PRODUCTS

#### 2.1 PIPE HANGERS AND SUPPORTS

- A. Manufacturers:
  - 1. Anvil
  - 2. PT&P
  - 3. Carpenter & Paterson Inc.
  - 4. Creative Systems Inc.
  - 5. Flex-Weld, Inc.
  - 6. Glope Pipe Hanger Products Inc.
  - 7. Michigan Hanger Co.
  - 8. Superior Valve Co.
  - 9. Substitutions: Section 01630 - Product Requirements and Substitutions
- B. All hangers, rods, clamps, protective shields, components, and hanger accessories shall be hot-dipped-galvanized unless noted otherwise. Galvanized item shall be hot dipped galvanized (HDG). Strap type hangers shall not be used on any piping system unless otherwise noted; use only clevis type.
- C. Piping:
  - 1. Conform to ASME B31.9, MSS SP58, MSS, and SP69.
  - 2. Hangers for Pipe Sizes 1/2 to 1-1/2 inch: Malleable iron, adjustable swivel, split ring.

3. Hangers for Cold Pipe Sizes 2 inches and Larger: Carbon steel (hot dipped galvanized), adjustable, clevis.
  4. Hangers for Hot Pipe Sizes 2 to 4 inches: Carbon steel (hot dipped galvanized), adjustable, clevis.
  5. Hangers for Hot Pipe Sizes 6 inches and Larger: Adjustable steel yoke, cast iron roll, double hanger.
  6. Multiple or Trapeze Hangers: Steel channels with welded spacers and hanger rods.
  7. Multiple or Trapeze Hangers for Hot Pipe Sizes 6 inches and Larger: Steel channels with welded spacers and hanger rods, cast iron roll.
  8. Wall Support for Pipe Sizes 3 inches and Smaller: steel channel with pipe clamp.
  9. Wall Support for Pipe Sizes 4 inches and Larger: Welded steel bracket and wrought steel clamp.
  10. Vertical Support: Steel riser clamp.
  11. Floor Support for Cold Pipe: Cast iron adjustable pipe saddle, lock nut, nipple, floor flange, and concrete pier or steel support.
  12. Floor Support for Hot Pipe Sizes 4 Inches and Smaller: Cast iron adjustable pipe saddle, lock nut, nipple, floor flange, and concrete pier or steel support.
  13. Floor Support for Hot Pipe Sizes 6 inches and Larger: Adjustable cast iron roll and stand, steel screws, and concrete pier or steel support.
  14. All exposed carbon steel material shall be coated with hot dipped galvanize.
- D. Steam and Steam Condensate Piping:
1. Conform to ASME B31.1, ASME B31.9, MSS SP58, and MSS SP69.
  2. Hangers for Pipe Sizes 1/2 to 1-1/2 inch: Malleable iron, adjustable swivel, split ring.
  3. Hangers for Pipe Sizes 2 to 4 inches: Carbon steel (hot dipped galvanized), adjustable, clevis.
  4. Hangers for Pipe Sizes 6 inches and Larger: Adjustable steel yoke, cast iron roll, double hanger.
  5. Multiple or Trapeze Hangers for Pipe Sizes 4 inches and Smaller: Steel channels with welded spacers and hanger rods.
  6. Multiple or Trapeze Hangers for Pipe Sizes 6 inches and Larger: Steel channels with welded spacers and hanger rods; cast-iron roll and stand.
  7. Wall Support for Pipe Sizes 3 inches and Smaller: Steel channel with pipe clamp.
  8. Wall Support for Pipe Sizes 4 to 5 inches: Welded steel bracket and wrought steel clamp.
  9. Wall Support for Pipe Sizes 6 inches and Larger: Welded steel bracket and wrought steel clamp; adjustable steel yoke and cast iron roll.
  10. Vertical Support: Steel riser clamp.
  11. Floor Support for Pipe Sizes 4 inches and Smaller: Cast iron adjustable pipe saddle, lock nut, nipple, floor flange, and concrete pier or steel support.
  12. Floor Support for Pipe Sizes 6 inches and Larger: Adjustable cast iron roll and stand steel screws, and concrete pier or steel support.
  13. Guide for Pipe Sizes 1 to 24": Spider type, carbon steel, adjustable.
  14. Anchor for Pipe Sizes to 12": Carbon steel, with bottom base welded to pipe and support steel to prevent pipe movement
  15. All exposed carbon steel material shall be coated with hot dipped galvanized (HGD).

## 2.2 ACCESSORIES

- A. Hanger Rods: All galvanized steel or stainless steel threaded both ends, threaded on one end, or continuous threaded.
- B. Anchors and Bolts: Bolts and studs shall conform with A260 or A493, as applicable. Nuts shall conform to ASTM F524 and washers shall conform to ASTM A240, A260, or 493 as applicable. Bolts and studs, nuts and washers shall be AISI Type 304 stainless steel.
- C. Fasteners and Accessories: Provide anchors and fasteners, washers, straps, and accessories required for a complete and finished installation. Fasteners shall be AISI Type 304 stainless steel.

## 2.3 FLASHING

- A. Metal Flashing: 26 gage thick galvanized steel.
- B. Metal Counterflashing: 22 gage thick galvanized steel.
- C. Lead Flashing:
  - 1. Waterproofing: 5 lb./sq. ft sheet lead.
  - 2. Soundproofing: 1 lb./sq. ft sheet lead.
- D. Flexible Flashing: 47 mil thick sheet butyl; compatible with roofing.
- E. Caps: Steel, 22 gage minimum; 16 gage at fire resistant elements.

## 2.4 SLEEVES

- A. Sleeves for Pipes Through Non-fire Rated Floors: 18 gage thick galvanized steel.
- B. Sleeves for Pipes Through Non-fire Rated Beams, Walls, Footings, and Potentially Wet Floors: Steel pipe or 18 gage thick galvanized steel.
- C. Sealant: Acrylic; See Section 07 90 00.
- D. Escutcheons:
  - 1. Public Areas: Solid plate stainless steel with satin finish.
  - 2. Non-Public Areas: Split ring chrome plated with set screws.
  - 3. Size: Minimum one inch annulus shall be provided except at building seismic joints. Building seismic joint pipe sleeves shall be minimum of 5 inches greater than the normal diameter of the pipe, or as indicated.

## 2.5 MECHANICAL SLEEVE SEALS

- A. Manufacturers:
  - 1. Thunderline Link-Seal, Inc.
  - 2. NMP Corporation
  - 3. Substitutions: Section 01630 - Product Requirements and Substitutions

- B. Product Description: Modular mechanical type, consisting of interlocking synthetic rubber links shaped to continuously fill annular space between object and sleeve, connected with bolts and pressure plates causing rubber sealing elements to expand when tightened, providing watertight seal and electrical insulation.

## 2.6 FORMED STEEL CHANNEL

- A. Manufacturers:
  - 1. Allied Tube & Conduit Corp.
  - 2. B-Line Systems
  - 3. Midland Ross Corporation, Electrical Products Division
  - 4. Unistrut Corp.
  - 5. Substitutions: Section 01630 - Product Requirements and Substitutions
- B. Product Description: HDG channels shall be 12 gage for steel thickness. With holes 1-1/2 inches on center. Surface finish shall be hot dip galvanized (HDG) after fabrication of channels. Provide galvanized touch-up paint to cut or exposed ends. Provide shop drawings and design data.

## 2.7 FIRESTOPPING

- A. Manufacturers:
  - 1. Dow Corning Corp.
  - 2. Fire Trak Corp.
  - 3. Hilti Corp.
  - 4. International Protective Coating Corp.
  - 5. 3M fire Protection Products
  - 6. Specified Technology, Inc.
  - 7. Substitutions: Section 01630 - Product Requirements and Substitutions
- B. Product Description: Different types of products by multiple manufacturers are acceptable as required to meet specified system description and performance requirements; provide only one type for each similar application.
  - 1. Silicone Firestopping Elastomeric Firestopping: Single or Multiple component silicone elastomeric compound and compatible silicone sealant.
  - 2. Formulated Firestopping Compound of Incombustible Fibers: Formulated compound mixed with incombustible non-asbestos fibers.

## 2.8 FIRESTOPPING ACCESSORIES

- A. Primer: Type recommended by firestopping manufacturer for specific substrate surfaces and suitable for required fire ratings.
- B. Dam Material: Permanent:
  - 1. Mineral fiberboard.
  - 2. Mineral fiber matting.
  - 3. Sheet metal.
  - 4. Plywood or particle board.
  - 5. Alumina silicate fire board.

- C. Installation Accessories: Provide clips, collars, fasteners, temporary stops or dams, and other devices required to position and retain materials in place.
- D. General:
  - 1. Furnish UL listed products or products tested by independent testing laboratory.
  - 2. Select products with rating not less than rating of wall or floor being penetrated.
- E. Non-Rated Surfaces:
  - 1. Stamped steel, chrome plated, hinged, split ring escutcheons or floor plates or ceiling plates for covering openings in occupied areas where piping is exposed.
  - 2. For exterior wall openings below grade, furnish mechanical sealing device to continuously fill annular space between piping and cored opening or water-stop type wall sleeve.

## 2.9 SEISMIC REQUIREMENTS

- A. Seismic restraints, anchorage and reinforcements shall be provided for all piping. Equipment and piping shall be anchored to withstand forces generated by earthquake movements. As a minimum, pipe seismic restraints, supports and anchors shall be designed to withstand a force of 100 percent of the weight of the pipe, full of water, plus weight of valves and fittings attached and 250 pounds with the force acting at the pipe center of gravity in any direction.
- B. All piping shall be seismic braced, as a minimum as follows:
  - 1. At all changes in direction provide transverse and longitudinal braces.
  - 2. Provide transverse braces maximum of 40 feet on center.
  - 3. Provide longitudinal braces maximum of 80 feet on center.
- C. Braces shall consist of components specifically designed for intended service, galvanized (except pipe hanger in contact with copper pipes) and complete with galvanized pipe chord member.
- D. See Structural drawings for additional seismic requirements.

## PART 3 EXECUTION

### 3.1 EXAMINATION

- A. Verify openings are ready to receive sleeves.
- B. Verify openings are ready to receive firestopping.

### 3.2 PREPARATION

- A. Clean substrate surfaces of dirt, dust, grease, oil, loose material, or other matter affecting bond of firestopping material.
- B. Remove incompatible materials affecting bond.

- C. Install backing damming materials to arrest liquid material leakage.
- D. Obtain permission from Architect/Engineer before using powder-actuated anchors.
- E. Do not drill or cut structural members.

### 3.3 INSTALLATION - INSERTS

- A. Where inserts are omitted, drill through concrete slab from below and provide through-bolt with recessed square steel plate and nut above flush with top of or recessed into and grouted flush with slab.

### 3.4 INSTALLATION - PIPE HANGERS AND SUPPORTS

- A. Design and install in accordance with ASME B31.1, ASME B31.5, ASME 31.9, MSS SP 58, or MSS SP 69.
- B. Support horizontal piping as scheduled.
- C. Install hangers with minimum 1/2 inch space between finished covering and adjacent work.
- D. Place hangers within 12 inches of each horizontal elbow.
- E. Use hangers with 1-1/2 inch minimum vertical adjustment.
- F. Support vertical piping at every floor. Use approved steel brackets to prevent swaying, sagging, vibration, and resonance; however, allow for thermal expansion between supports or anchors.
- G. Where piping is installed in parallel and at same elevation, provide multiple pipe or trapeze hangers.
- H. Support riser piping independently of connected horizontal piping.
- I. Design hangers for pipe movement without disengagement of supported pipe.
- J. Prime coat exposed steel hangers and supports, except galvanized. Refer to Section 09 90 00. Hangers and supports located in crawl spaces, pipe shafts, and suspended ceiling spaces are not considered exposed.
- K. Provide clearance in hangers and from structure and other equipment for installation of insulation. Refer to Section 23 07 00.
- L. Pipe guides and anchors shall be provided at horizontal and vertical locations where necessary to keep pipes in acceptable alignment, to direct the expansion movement, and to prevent buckling and swaying due to gravity, seismic, wind and thermal loads.
- M. Do not support piping by wire, rope, strap, chain, wood, or similar makeshift devices.



- N. Hose faucets, compressed air outlets, and similar fixtures at ends of pipe branches shall be supported within 3 inches.
- O. When piping to equipment is mounted on vibration isolators, provide spring cushion or other approved type of isolation hanger on the nearest pipe support and on each side of the equipment.
- P. Install hangers and supports complete with necessary inserts, bolts, rods, nuts, washers, and other accessories. All piping supports shall be in compliance with seismic requirements stated in Section 2.9.
- Q. Provide field fabricated, heavy-duty steel trapezes fabricated from steel shapes selected for loads required and welded in accordance with applicable requirements of Section 05 05 22 – Metal Welding.
- R. Support fire protection systems piping independently from other piping systems.
- S. The necessary hangers and supports, including beam and purlin clamps, rods, pipe rolls, angles, channels and plates, and any changes from indicated design, shall be approved by the Engineer before installation.
- T. Use of building structural steel for supporting hangers will not be permitted unless indicated or approved by the Engineer.
- U. Support for Insulated Piping:
  - 1. For insulated hot and cold water lines, unless otherwise indicated, use insulation inserts as required for supporting piping from exterior of insulation.
  - 2. Pipe less than 2 inches may be supported from insulation with galvanized steel half round protective shields.
  - 3. For vertical piping 4 inches and larger, provide angle or plate type insulation supports welded to pipe at approximately 12 foot intervals. Fabricate these supports of same material as pipe that they are attached to, and of widths less than thickness of insulation covering.
  - 4. Install hangers around outside of low temperature insulation. Insert section of one inch long by 180 degree cellular glass, minimum eight pounds per cubic foot density, with vapor barrier jacket plus 18 gage by 10 inch by 180 degree galvanized steel shield. Special hangers equipped with equivalent insulating material and vapor barrier may be used.

### 3.5 INSTALLATION - EQUIPMENT BASES AND SUPPORTS

- A. Provide housekeeping pads of concrete, minimum 3-1/2 inches thick and extending a minimum of 6 inches beyond supported equipment. Refer to Section 03 30 00. See Structural Drawings.
- B. Using templates furnished with equipment, install anchor bolts, and accessories for mounting and anchoring equipment.
- C. Construct supports of steel members. Brace and fasten with flanges bolted to structure.

- D. Provide rigid anchors for pipes after vibration isolation components are installed.

### 3.6 INSTALLATION - FLASHING

- A. Provide flexible flashing and metal Counterflashing where piping and ductwork penetrate weather or waterproofed walls, floors, and roofs.
- B. Provide acoustical lead flashing around ducts and pipes penetrating equipment rooms for sound control.

### 3.7 INSTALLATION – SLEEVES

- A. General Requirement:
  - 1. Provide a pipe sleeve where each pipe passes through an exterior or interior wall, floor, ceiling, or roof, and at other locations indicated.
  - 2. Set pipe sleeves parallel to the pipes that pass through them.
  - 3. Do not install sleeves in structural members except where indicated or approved.
  - 4. Secure sleeves to concrete forms to prevent displacement during placement of concrete.
- B. Exterior watertight entries: Seal with mechanical sleeve seals.
- C. Set sleeves in position in forms. Provide reinforcing around sleeves.
- D. Size sleeves large enough to allow for movement due to expansion and contraction. Provide for continuous insulation wrapping.
- E. Extend sleeves through floors 1 inch above finished floor level. Caulk sleeves.
- F. Where piping or ductwork penetrates floor, ceiling, or wall, close off space between pipe or duct and adjacent work with firestopping insulation and caulk airtight. Provide close fitting metal collar or escutcheon covers at both sides of penetration.
- G. Install chrome plated steel, stainless steel escutcheons at finished surfaces.

### 3.8 INSTALLATION - FIRESTOPPING

- A. Install material at fire rated construction perimeters and openings containing penetrating sleeves, piping, ductwork, and other items, requiring firestopping.
- B. Apply primer where recommended by manufacturer for type of firestopping material and substrate involved, and as required for compliance with required fire ratings.
- C. Apply firestopping material in sufficient thickness to achieve required fire and smoke rating, to uniform density and texture.
- D. Fire Rated Surface:
  - 1. Seal opening at floor, wall, partition, ceiling, and roof as follows:
    - a. Install sleeve through opening and extending beyond minimum of 1 inch on both sides of building element.

- b. Size sleeve allowing minimum of 1 inch void between sleeve and building element.
    - c. Pack void with backing material.
    - d. Seal ends of sleeve with UL listed fire resistive silicone compound to meet fire rating of structure penetrated.
  2. Where cable tray, bus, cable bus, conduit, wireway, trough, and penetrates fire rated surface, install firestopping product in accordance with manufacturer's instructions.
- E. Non-Rated Surfaces:
  1. Seal opening through non-fire rated wall, partition, floor, ceiling, and roof opening as follows:
    - a. Install sleeve through opening and extending beyond minimum of 1 inch on both sides of building element.
    - b. Size sleeve allowing minimum of 1 inch void between sleeve and building element.
    - c. Install type of firestopping material recommended by manufacturer.
  2. Install escutcheons, floor plates, or ceiling plates where conduit, penetrates non-fire rated surfaces in occupied spaces. Occupied spaces include rooms with finished ceilings and where penetration occurs below finished ceiling.
  3. Exterior wall openings below grade: Assemble rubber links of mechanical sealing device to size of piping and tighten in place, in accordance with manufacturer's instructions.
  4. Interior partitions: Seal pipe penetrations. Apply sealant to both sides of penetration to completely fill annular space between sleeve and conduit.

### 3.9 FIELD QUALITY CONTROL

- A. Section 01780 – Project Closeout: Field inspecting, testing, adjusting, and balancing.
- B. Inspect installed firestopping for compliance with specifications and submitted schedule.

### 3.10 CLEANING

- A. Section 01780 - Project Closeout: Final cleaning.
- B. Clean adjacent surfaces of firestopping materials.

### 3.11 PROTECTION OF FINISHED WORK

- A. Protect adjacent surfaces from damage by material installation.

### 3.12 SCHEDULES

- A. Copper and Steel Pipe Hanger Spacing:

PIPE SIZE Inches	COPPER TUBING MAXIMUM HANGER SPACING Feet	STEEL PIPE MAXIMUM HANGER SPACING Feet	COPPER TUBING HANGER ROD DIAMETER Inches	STEEL PIPE HANGER ROD DIAMETER Inches
1/2	5	7	3/8	3/8
3/4	5	7	3/8	3/8
1	6	7	3/8	3/8
1-1/4	7	7	3/8	3/8
1-1/2	8	9	3/8	3/8
2	8	10	3/8	3/8
2-1/2	9	11	1/2	1/2
3	10	12	1/2	1/2
4	12	14	1/2	5/8
5	13	16	1/2	5/8
6	14	17	5/8	3/4
8	16	19	3/4	3/4
10	18	22	3/4	7/8
12	19	23	3/4	7/8
14	22	25	7/8	1
16	23	27	7/8	1
18	25	28	1	1
20	27	30	1	1-1/4
24	28	32	1-1/4	1-1/4

For grooved end piping systems refer to manufacturer's recommendations.

END OF SECTION

SECTION 23 05 48

VIBRATION AND SEISMIC CONTROLS FOR PIPING AND EQUIPMENT

PART 1 GENERAL

1.1 SUMMARY

- A. Section Includes:
  - 1. Equipment bases.
  - 2. Vibration isolators.
  - 3. Inertia bases.
- B. Related Sections:
  - 1. Section 03 30 00 – Cast-in-Place Concrete.
  - 2. Section 23 05 29 - Hangers and Supports for Piping and Equipment.
  - 3. Section 23 05 93 - Testing, Adjusting, and Balancing for HVAC.

1.2 REFERENCES

- A. American National Standards Institute:
  - 1. ANSI S1.4 - Sound Level Meters.
  - 2. ANSI S1.8 - Reference Quantities for Acoustical Levels.
  - 3. ANSI S1.13 - Methods for the Measurement of Sound Pressure Levels in Air.
  - 4. ANSI S12.36 - Survey Methods for the Determination of Sound Power Levels of Noise Sources.
- B. Air-Conditioning and Refrigeration Institute:
  - 1. ARI 575 - Method of Measuring Machinery Sound within Equipment Space.
- C. American Society of Heating, Refrigerating and:
  - 1. ASHRAE 68 - Laboratory Method of Testing In-Duct Sound Power Measurement Procedure for Fans.
  - 2. ASHRAE Handbook - HVAC Applications.
- D. ASTM International:
  - 1. ASTM E90 - Standard Test Method for Laboratory Measurement of Airborne Sound Transmission Loss of Building Partitions and Elements.
  - 2. ASTM E477 - Standard Test Method for Measuring Acoustical and Airflow Performance of Duct Liner Materials and Prefabricated Silencers.
  - 3. ASTM E596 - Standard Test Method for Laboratory Measurement of the Noise Reduction of Sound-Isolating Enclosures.

1.3 PERFORMANCE REQUIREMENTS

- A. Provide vibration isolation on motor driven equipment over 0.5 hp, plus connected piping where indicated.

Use concrete inertia bases on base mounted pumps indoors over 10 hp.

- B. Provide minimum static deflection of isolators for equipment as follows:
  - 1. Basement, Under 20 hp
    - a. 400 - 600 rpm: 1 inch
    - b. 600 - 800 rpm: 0.5 inch
    - c. 800 - 900 rpm: 0.2 inch
    - d. 1100 - 1500 rpm: 0.14 inch
    - e. Over 1500 rpm: 0.1 inch
  - 2. Basement, Over 20 hp
    - a. 400 - 600 rpm: 2 inch
    - b. 600 - 800 rpm: 1 inch
    - c. 800 - 900 rpm: 0.5 inch
    - d. 1100 - 1500 rpm: 0.2 inch
    - e. Over 1500 rpm: 0.15 inch

#### 1.4 SUBMITTALS

- A. Section 01300 - Submittals: Submittal procedures.
- B. Shop Drawings: Indicate inertia bases, isolation pads and locate vibration isolators, with static and dynamic load on each. Indicate assembly, materials, thickness, dimensional data, pressure losses, acoustical performance, layout, and connection details for sound attenuation products fabricated for this project.
- C. Product Data: Submit schedule of vibration isolator type with location and load on each. Submit catalog information indicating, materials, dimensional data, pressure losses, and acoustical performance for standard sound attenuation products.
- D. Design Data: Submit calculations indicating maximum room sound levels are not exceeded.
- E. Test Reports: Indicate acoustic housings meet or exceed specified sound transmission loss values.
- F. Manufacturer's Installation Instructions: Submit special procedures and setting dimensions. Indicate installation requirements maintaining integrity of sound isolation.
- G. Manufacturer's Certificate: Certify isolators meet or exceed specified requirements.
- H. Manufacturer's Field Reports: Indicate sound isolation installation is complete and in accordance with instructions.

#### 1.5 CLOSEOUT SUBMITTALS

- A. Section 01780 – Contract Closeout: Closeout procedures.
- B. Project Record Documents: Record actual locations of cross-talk silencers. acoustic housings. ductwork lagging. Record actual locations of hangers including attachment points.

## 1.6 QUALITY ASSURANCE

- A. Perform Work in accordance with AMCA 300, ANSI S1.13, ARI 575, and ANSI S12.36 standards and recommendations of ASHRAE 68.
- B. Maintain one copy of each document on site.

## 1.7 QUALIFICATIONS

- A. Manufacturer: Company specializing in manufacturing products specified in this section with minimum three years documented experience.
- B. Installer: Company specializing in performing Work of this section with minimum three years documented experience and/or approved by manufacturer.

## 1.8 PRE-INSTALLATION MEETINGS

- A. Section 01040 – Project Coordination: Pre-installation meeting.
- B. Convene minimum one week prior to commencing work of this section.

## 1.9 FIELD MEASUREMENTS

- A. Verify field measurements prior to fabrication.

## 1.10 WARRANTY

- A. Section 01780 – Contract Closeout: Warranties and Bonds.
- B. Furnish five year manufacturer warranty for inertia bases.

## PART 2 PRODUCTS

### 2.1 EQUIPMENT BASES

- A. Structural Bases:
  - 1. Design: Sufficiently rigid to prevent misalignment or undue stress on machine, and to transmit design loads to isolators and snubbers.
  - 2. Construction: Welded structural steel with gusset brackets, supporting equipment and motor with motor slide rails.

### 2.2 VIBRATION ISOLATORS

- A. Manufacturers:
  - 1. Mason
  - 2. Vibrasystem
  - 3. Caldyn
  - 4. Kinetics (Cooling Tower)

5. Substitutions: Section 01630 - Product Requirement and Substitutions.
- B. Neoprene Pad Isolators:
1. Rubber or neoprene-waffle pads.
    - a. 30 durometer.
    - b. Minimum 1/2 inch thick.
    - c. Maximum loading 40 psi.
    - d. Height of ribs: not to exceed 0.7 times width.
  2. Configuration: 1/2 inch thick waffle pads bonded each side of 1/4 inch thick steel plate.
- C. Seismic Snubbers:
1. Type: Non-directional and double acting unit consisting of interlocking steel members restrained by neoprene elements.
  2. Neoprene Elements: Replaceable, minimum of 0.75 inch thick.
  3. Capacity: 4 times load assigned to mount groupings at 0.4 inch deflection.
  4. Attachment Points and Fasteners: Capable of withstanding 3 times rated load capacity of seismic snubber.
  5. See structural drawings for equipment weights.

### 2.3 INERTIA BASES

- A. Manufacturers:
1. Mason Industries
  2. Kinetics Noise Control
  3. Vibrasystems
  4. Substitutions: Section 01630 – Product Requirements and Substitutions
- B. Structural Bases:
1. Design: Sufficiently rigid to prevent misalignment or undue stress on machine, and to transmit design loads to isolators and snubbers.
  2. Construction: Welded structural steel with gusset brackets, supporting equipment and motor with motor slide rails.
- C. Concrete Inertia Bases:
1. Mass: Minimum of 1.5 times weight of isolated equipment.
  2. Construction: Structured steel channel perimeter frame, with gusset brackets and anchor bolts, adequately reinforced, concrete filled.
  3. Connecting Point: Reinforced to connect isolators and snubbers to base.
  4. Concrete: Reinforced 3,000 psi concrete.

## PART 3 EXECUTION

### 3.1 EXAMINATION

- A. Verify equipment, ductwork and piping is installed before work in this section is started.



### 3.2 EXISTING WORK

- A. Provide access to existing piping and ductwork and other installations remaining active and requiring access.
- B. Extend existing piping installations using materials and methods compatible with existing installations.

### 3.3 INSTALLATION

- A. Install isolation for motor driven equipment.
- B. Bases: Set steel bases for 1 inch clearance between housekeeping pad and base.
- C. Adjust equipment level.
- D. Install spring hangers without binding.
- E. On closed spring isolators, adjust so side stabilizers are clear under normal operating conditions.
- F. Prior to making piping connections to equipment with operating weights substantially different from installed weights, block up equipment with temporary shims to final height. When full load is applied, adjust isolators to load to allow shim removal.
- G. Provide resiliently mounted equipment, piping, and ductwork with seismic snubbers. Provide each inertia base with minimum of four seismic snubbers located close to isolators. Snub equipment designated for post disaster use to 0.05 inch maximum clearance. Provide other snubbers with clearance between 0.15 inch and 0.25 inch.
- H. Support piping connections to isolated equipment resiliently as follows:
  - 1. Up to 4 inch Diameter: First three points of support.
  - 2. 5 to 8 inch Diameter: First four points of support.
  - 3. 10 inch Diameter and Over: First six points of support.
  - 4. Select three hangers closest to vibration source for minimum 1.0 inch static deflection or static deflection of isolated equipment. Select remaining isolators for minimum 1.0 inch static deflection or 1/2 static deflection of isolated equipment.

### 3.4 FIELD QUALITY CONTROL

- A. Section 01400 - Quality Requirements
- B. Section 01780 - Contract Closeout Requirements: Field inspecting, testing, adjusting, and balancing.
- C. Inspect isolated equipment after installation and submit report. Include static deflections.
- D. After start-up, final corrections and balancing of systems take octave band sound measurements over full audio frequency range in areas adjacent to mechanical equipment

rooms, duct and pipe shafts, and other critical locations. Provide one-third octave band measurements of artificial sound sources in areas indicated as having critical requirements. Submit complete report of test results including sound curves.

- E. Furnish services of testing agency to take noise measurement. Use meters meeting requirements of ANSI S1.4.

3.5 SCHEDULES

- A. Equipment Isolation Schedule:

Isolated Equipment	Base Type	Isolator Type
Cooling Tower: Cooling Tower	Structural	Spring Isolator (See Section 23 65 00)

Note: OFCI = Owner Furnished Contractor Installed

END OF SECTION

SECTION 23 05 53

MECHANICAL IDENTIFICATION FOR PIPING AND EQUIPMENT

PART 1 GENERAL

1.1 SUMMARY

- A. Section Includes:
  - 1. Nameplates.
  - 2. Tags.
  - 3. Stencils.
  - 4. Pipe markers.
  - 5. Ceiling tacks.
  - 6. Labels.
  - 7. Lockout devices.
  - 8. Emergency signs.

1.2 REFERENCES

- A. American Society of Mechanical Engineers:
  - 1. ASME A13.1 - Scheme for the Identification of Piping Systems.
  - 2. NFPA 704 – Standard System for the Identification of the Hazardous Materials for Emergency Response, 2007 Edition.

1.3 SUBMITTALS

- A. Section 01300 - Submittals: Submittal procedures.
- B. Product Data: Submit manufacturers catalog literature for each product required.
- C. Shop Drawings: Submit list of wording, symbols, letter size, and color coding for mechanical identification and valve chart and schedule, including valve tag number, location, function, and valve manufacturer's name and model number. Valve tags shall be coordinated with PSU tag standards.
- D. Samples: Submit two tags, labels, pipe markers, for size used on project.
- E. Manufacturer's Installation Instructions: Indicate installation instructions, special procedures, and installation.
- F. Manufacturer's Certificate: Certify products meet or exceed specified requirements.

1.4 CLOSEOUT SUBMITTALS

- A. Section 01780 – Contract Closeout: Closeout procedures.
- B. Project Record Documents: Record actual locations of tagged valves; include valve tag numbers.

## 1.5 QUALITY ASSURANCE

- A. Conform to ASME A13.1 for color scheme for identification of piping systems and accessories.
- B. Maintain one copy of each document on site.

## 1.6 QUALIFICATIONS

- A. Manufacturer: Company specializing in manufacturing products specified in this section with minimum three years documented experience.
- B. Installer: Company specializing in performing Work of this section with minimum three years documented experience.

## 1.7 PRE-INSTALLATION MEETINGS

- A. Section 01040 – Project Coordination: Construction Coordination.
- B. Convene minimum one week prior to commencing work of this section.

## 1.8 FIELD MEASUREMENTS

- A. Verify field measurements prior to fabrication.

## 1.9 EXTRA MATERIALS

- A. Section 01780 – Contract Closeout: Spare parts and extra quantities.
- B. Furnish one container of spray-on adhesive.

## PART 2 PRODUCTS

### 2.1 NAMEPLATES

- A. Manufacturers:
  - 1. Craftmark Identification Systems
  - 2. Safety Sign Co.
  - 3. Seton Identification Products
  - 4. Brady
  - 5. Substitutions: Section 01630 - Product Requirements and Substitutions.
- B. Engraved stainless steel or laminated 1/8” thick three-layer plastic with engraved white letters on colored background color. Form letters by exposing center ply.

### 2.2 TAGS

- A. Plastic Tags:
  - 1. Manufacturers:

- a. Brady
  - b. Seton
  - c. Marking Systems
  - d. Substitutions: Refer to Section 01630 - Product Requirements and Substitutions
2. Laminated three-layer plastic with engraved white letters on contrasting background color. Tag size minimum 1-1/2 inches diameter.
- B. Metal Tags:
1. Manufacturers:
    - a. Brady
    - b. Seton
    - c. Substitutions: Refer to Section 01630 - Product Requirements and Substitutions
  2. Stainless Steel with stamped letters; tag size minimum 1-1/2 inches round with finished edges.
- C. Information Tags:
1. Manufacturers:
    - a. Brady
    - b. Seton
    - c. Marking Systems
    - d. Substitutions: Refer to Section 01630 - Product Requirements and Substitutions
  2. Clear plastic with printed "Danger," "Caution," or "Warning" and message; size 3-1/4 x 5-5/8 inches with grommet and self-locking nylon ties.
- D. Tag Chart: Typewritten letter size list of applied tags and location plastic laminated.

### 2.3 PIPE MARKERS

- A. Color and Lettering: Conform to ASME A13.1.
- B. Pipe Markers:
1. Manufacturers:
    - a. Brady
    - b. Seton
    - c. Marking Systems
    - d. Substitutions: Refer to Section 01630 - Product Requirements and Substitutions
  2. Flexible, vinyl film tape with pressure sensitive extra strength adhesive backing and printed markings.
- C. Underground Pipe Markers:
1. Manufacturers:
    - a. Brady
    - b. Seton

- c. Marking Systems
  - d. Substitutions: Refer to Section 01630 - Product Requirements and Substitutions
2. Bright colored continuously printed plastic ribbon tape, minimum 6 inches wide by 4 mil thick, manufactured for direct burial service.

## 2.4 EMERGENCY SIGNS

- A. Provide emergency signs for refrigeration equipment containing more than 220lbs of Type A refrigerant, per NFPA 704.

## PART 3 EXECUTION

### 3.1 PREPARATION

- A. Degrease and clean surfaces to receive adhesive for identification materials.
- B. Prepare surfaces in accordance with Section 09 90 00 for stencil painting.

### 3.2 INSTALLATION

- A. Apply stencil painting in accordance with Section 09 90 00.
- B. Install identifying devices after completion of coverings and painting.
- C. Install plastic nameplates with corrosive-resistant mechanical fasteners, or adhesive.
- D. Install labels with sufficient adhesive for permanent adhesion and seal with clear lacquer. For unfinished canvas covering, apply paint primer before applying labels.
- E. Install tags using corrosion resistant chain. Number tags consecutively by location.
- F. Install underground plastic pipe markers 6 to 8 inches below finished grade, directly above buried pipe.
- G. Identify air handling units, pumps, heat transfer equipment, tanks, and water treatment devices with nameplates. Identify in-line pumps and other small devices with tags.
- H. Identify control panels and major control components outside panels with plastic nameplates.
- I. Identify valves in main and branch piping with tags.
- J. Identify air terminal units and radiator valves with numbered tags.
- K. Tag automatic controls, instruments, and relays. Key to control schematic.
- L. Identify piping, concealed or exposed, with tape pipe markers, stenciled painting. Use tags on piping 3/4 inch diameter and smaller. Identify service, flow direction, and

pressure. Install in clear view and align with axis of piping. Locate identification not to exceed 20 feet on straight runs including risers and drops, adjacent to each valve and tee, at each side of penetration of structure or enclosure, and at each obstruction.

- M. Identify ductwork with plastic nameplates, or stenciled painting. Identify with air handling unit identification number and area served. Locate identification at air handling unit, at each side of penetration of structure or enclosure, and at each obstruction.

END OF SECTION

SECTION 23 05 93

TESTING, ADJUSTING, AND BALANCING FOR HVAC

PART 1 GENERAL

1.1 SUMMARY

- A. Section Includes:
  - 1. Testing, adjusting, and balancing of air systems.
  - 2. Testing, adjusting, and balancing of hydronic steam systems.
  - 3. Measurement of final operating condition of HVAC systems.
  - 4. Sound measurement of equipment operating conditions.
  - 5. Vibration measurement of equipment operating conditions.
  
- B. Related Sections:
  - 1. Section 23 09 23 - Direct-Digital Control System for HVAC: Requirements for coordination between DDC system and testing, adjusting, and balancing work.
  - 2. Section 23 09 93 - Sequence of Operations for HVAC Controls: Sequences of operation for HVAC equipment.
  - 3. Section 23 21 23 – Hydronic Pumps
  - 4. Section 23 22 23 – Steam Condensate Pumps
  - 5. Section 23 57 00 – Heat Exchangers
  - 6. Section 23 64 16 – Centrifugal Chiller
  - 7. Section 23 65 00 – Cooling Towers

1.2 REFERENCES

- A. Associated Air Balance Council:
  - 1. AABC MN-1 - National Standards for Testing and Balancing Heating, Ventilating, and Air Conditioning Systems.
  
- B. American Society of Heating, Refrigerating and Air-Conditioning Engineers:
  - 1. ASHRAE 111 - Practices for Measurement, Testing, Adjusting and Balancing of Building Heating, Ventilation, Air-Conditioning and Refrigeration Systems.
  
- C. Natural Environmental Balancing Bureau:
  - 1. NEBB - Procedural Standards for Testing, Adjusting, and Balancing of Environmental Systems.

1.3 SUBMITTALS

- A. Section 01300 - Submittal Procedures: Submittal procedures.
  
- B. Prior to commencing Work, submit proof of latest calibration date of each instrument.
  
- C. Test Reports: Indicate data on AABC MN-1 National Standards for Total System Balance forms or NEBB Report forms.



- D. Field Reports: Indicate deficiencies preventing proper testing, adjusting, and balancing of systems and equipment to achieve specified performance.
- E. Prior to commencing Work, submit report forms or outlines indicating adjusting, balancing, and equipment data required. Include detailed procedures, agenda, sample report forms and copy of AABC National Project Performance Guaranty or Copy of NEBB Certificate of Conformance Certification.
- F. Submit draft copies of report for review prior to final acceptance of Project.
- G. Furnish reports in letter size, 3-ring binder manuals, complete with table of contents page and indexing tabs, with cover identification at front and side. Include set of reduced drawings with air outlets and equipment identified to correspond with data sheets, and indicating thermostat locations.

#### 1.4 CLOSEOUT SUBMITTALS

- A. Section 01780 – Contract Closeout: Closeout procedures.
- B. Project Record Documents: Record actual locations of balancing valves and rough setting.
- C. Operation and Maintenance Data: Furnish final copy of testing, adjusting, and balancing report inclusion in operating and maintenance manuals.

#### 1.5 QUALITY ASSURANCE

- A. Perform Work in accordance with AABC MN-1 National Standards for Field Measurement and Instrumentation, Total System Balance or NEBB Procedural Standards for Testing, Balancing and Adjusting of Environmental Systems.
- B. Maintain one copy of each document on site.
- C. Prior to commencing Work, calibrate each instrument to be used.

#### 1.6 QUALIFICATIONS

- A. Agency: Company specializing in testing, adjusting, and balancing of systems specified in this section with minimum five years documented experience certified by AABC or Certified by NEBB.
- B. Perform Work under supervision of AABC Certified Test and Balance Engineer or NEBB Certified Testing, Balancing and Adjusting Supervisor.

#### 1.7 PRE-INSTALLATION MEETINGS

- A. Section 01040 – Project Coordination: Pre-installation meeting.
- B. Convene minimum one week prior to commencing work of this section.

## 1.8 SEQUENCING

- A. Sequence balancing between completion of systems tested and Date of Substantial Completion.

## 1.9 SCHEDULING

- A. Section 01040 – Project Coordination: Coordination and project conditions.

## PART 2 PRODUCTS

Not Used.

## PART 3 EXECUTION

### 3.1 EXAMINATION

- A. Section 01040 – Project Coordination: Coordination and project conditions.
- B. Verify systems are complete and operable before commencing work. Verify the following:
  1. Systems are started and operating in safe and normal condition.
  2. Temperature control systems are installed complete and operable.
  3. Proper thermal overload protection is in place for electrical equipment.
  4. Final filters are clean and in place. If required, install temporary media in addition to final filters.
  5. Duct systems are clean of debris.
  6. Fans are rotating correctly.
  7. Fire and volume dampers are in place and open.
  8. Air coil fins are cleaned and combed.
  9. Access doors are closed and duct end caps are in place.
  10. Air outlets are installed and connected.
  11. Duct system leakage is minimized.
  12. Hydronic systems are flushed, filled, and vented.
  13. Pumps are rotating correctly.
  14. Proper strainer baskets are clean and in place or in normal position.
  15. Service and balancing valves are open.

### 3.2 PREPARATION

- A. Furnish instruments required for testing, adjusting, and balancing operations.
- B. Make instruments available to Architect/Engineer to facilitate spot checks during testing.

### 3.3 INSTALLATION TOLERANCES

- A. Air Handling Systems: Adjust to within plus or minus 10 percent of design.

- B. Air Outlets and Inlets: Adjust total to within plus 10 percent and minus 5 percent of design to space. Adjust outlets and inlets in space to within plus or minus 10 percent of design.
- C. Hydronic Systems: Adjust to within plus or minus 5 percent of design.

### 3.4 ADJUSTING

- A. Section 01780 – Contract Closeout: Testing, adjusting, and balancing.
- B. Verify recorded data represents actual measured or observed conditions.
- C. Permanently mark settings of valves, dampers, and other adjustment devices allowing settings to be restored. Set and lock memory stops.
- D. After adjustment, take measurements to verify balance has not been disrupted. If disrupted, verify correcting adjustments have been made.
- E. Report defects and deficiencies noted during performance of services, preventing system balance.
- F. Leave systems in proper working order, replacing belt guards, closing access doors, closing doors to electrical switch boxes, and restoring thermostats to specified settings.
- G. At final inspection, recheck random selections of data recorded in report. Recheck points or areas as selected and witnessed by Owner.
- H. Check and adjust systems approximately six months after final acceptance and submit report.

### 3.5 AIR SYSTEM PROCEDURE

- A. Adjust air handling and distribution systems to obtain required or design supply, return, and exhaust air quantities.
- B. Make air quantity measurements in main ducts by Pitot tube traverse of entire cross sectional area of duct.
- C. Measure air quantities at air inlets and outlets.
- D. Adjust distribution system to obtain uniform space temperatures free from objectionable drafts.
- E. Use volume control devices to regulate air quantities only to extent adjustments do not create objectionable air motion or sound levels. Effect volume control by using volume dampers located in ducts.
- F. Vary total system air quantities by adjustment of fan speeds. Provide sheave drive changes to vary fan speed. Vary branch air quantities by damper regulation.

- G. Provide system schematic with required and actual air quantities recorded at each outlet or inlet.
- H. Measure static air pressure conditions on air supply units, including filter and coil pressure drops, and total pressure across fan. Make allowances for 50 percent loading of filters.
- I. Adjust outside air automatic dampers, outside air, return air, and exhaust dampers for design conditions.
- J. Measure temperature conditions across outside air, return air, and exhaust dampers to check leakage.
- K. At modulating damper locations, take measurements and balance at extreme conditions. Balance variable volume systems at maximum airflow rate, full cooling, and at minimum airflow rate.
- L. Measure building static pressure and adjust supply, return, and exhaust air systems to obtain required relationship between each to maintain approximately 0.05 inches positive static pressure.
- M. For variable air volume system powered units set volume controller to airflow setting indicated. Confirm connections properly made and confirm proper operation for automatic variable-air-volume temperature control.

### 3.6 WATER SYSTEM PROCEDURE

- A. Adjust water systems, after air balancing, to obtain design quantities.
- B. Use calibrated fittings and pressure gauges to determine flow rates for system balance. Where flow-metering devices are not installed, base flow balance on temperature difference across various heat transfer elements in system.
- C. Adjust systems to obtain specified pressure drops and flows through heat transfer elements prior to thermal testing. Perform balancing by measurement of temperature differential in conjunction with air balancing.
- D. Effect system balance with automatic control valves fully open or in normal position to heat transfer elements.
- E. Effect adjustment of water distribution systems by means of balancing cocks, valves, and fittings. Do not use service or shut-off valves for balancing unless indexed for balance point.
- F. Where available pump capacity is less than total flow requirements or individual system parts, simulate full flow in one part by temporary restriction of flow to other parts.

### 3.7 SCHEDULES

- A. Base Bid Equipment Requiring Testing, Adjusting, and Balancing:
  - 1. Plumbing Pumps: All shown.
  - 2. Steam Condensate Pumps: SB2-CP-01
  - 3. Chilled Water Pumps: SB2-CHP-01, SB2-CHP-02, and ML-P4
  - 4. Centrifugal Water Chillers: SB2-CH-02 and SB2-CH-03.
  - 5. Induced Draft Cooling Tower: SB2-CT-01 and SB2-CT-02
  - 6. Condenser Water Pumps: SB2-P13 and SB2-CDP-01
  - 7. Air Handling Units.
  - 8. Fans.
  - 9. Air Filters.
  - 10. Air Terminal Units.
  - 11. Air Inlets and Outlets.
  
- B. Alternate Bid Equipment Requiring Testing, Adjusting, and Balancing:
  - 1. Well Water Pumps: SB2-WWP-01
  - 2. Heat Exchanger
  - 3. Steam Condensate Pump: CH-PCR-01
  
- C. Report Forms
  - 1. Title Page:
    - a. Name of Testing, Adjusting, and Balancing Agency
    - b. Address of Testing, Adjusting, and Balancing Agency
    - c. Telephone and facsimile numbers of Testing, Adjusting, and Balancing Agency
    - d. Project name
    - e. Project location
    - f. Project Architect
    - g. Project Engineer
    - h. Project Contractor
    - i. Project altitude
    - j. Report date
  - 2. Summary Comments:
    - a. Design versus final performance
    - b. Notable characteristics of system
    - c. Description of systems operation sequence
    - d. Summary of outdoor and exhaust flows to indicate building pressurization
    - e. Nomenclature used throughout report
    - f. Test conditions
  - 3. Instrument List:
    - a. Instrument
    - b. Manufacturer
    - c. Model number
    - d. Serial number
    - e. Range
    - f. Calibration date

4. Electric Motors:
  - a. Manufacturer
  - b. Model/Frame
  - c. HP/BHP and kW
  - d. Phase, voltage, amperage; nameplate, actual, no load
  - e. RPM
  - f. Service factor
  - g. Starter size, rating, heater elements
  - h. Sheave Make/Size/Bore
5. V-Belt Drive:
  - a. Identification/location
  - b. Required driven RPM
  - c. Driven sheave, diameter and RPM
  - d. Belt, size and quantity
  - e. Motor sheave diameter and RPM
  - f. Center to center distance, maximum, minimum, and actual
6. Pump Data:
  - a. Identification/number
  - b. Manufacturer
  - c. Size/model
  - d. Impeller
  - e. Service
  - f. Design flow rate, pressure drop, BHP and kW
  - g. Actual flow rate, pressure drop, BHP and kW
  - h. Discharge pressure
  - i. Suction pressure
  - j. Total operating head pressure
  - k. Shut off, discharge and suction pressures
  - l. Shut off, total head pressure
7. Chillers:
  - a. Identification/number
  - b. Manufacturer
  - c. Capacity
  - d. Model number
  - e. Serial number
  - f. Evaporator entering water temperature, design and actual
  - g. Evaporator leaving water temperature, design and actual
  - h. Evaporator pressure drop, design and actual
  - i. Evaporator water flow rate, design and actual
  - j. Condenser entering water temperature, design and actual
  - k. Condenser pressure drop, design and actual
  - l. Condenser water flow rate, design and actual
8. Cooling Tower:
  - a. Tower identification/number
  - b. Manufacturer
  - c. Model number
  - d. Serial number
  - e. Rated capacity

- f. Entering air WB temperature, specified and actual
  - g. Leaving air WB temperature, specified and actual
  - h. Ambient air DB temperature
  - i. Condenser water entering temperature
  - j. Condenser water leaving temperature
  - k. Condenser water flow rate
  - l. Fan RPM
9. Heat Exchanger:
- a. Identification/number
  - b. Location
  - c. Service
  - d. Manufacturer
  - e. Model number
  - f. Serial number
  - g. Steam pressure, design and actual
  - h. Primary water entering temperature, design and actual
  - i. Primary water leaving temperature, design and actual
  - j. Primary water flow, design and actual
  - k. Primary water pressure drop, design and actual
  - l. Secondary water leaving temperature, design and actual
  - m. Secondary water leaving temperature, design and actual
  - n. Secondary water flow, design and actual
  - o. Secondary water pressure drop, design and actual
10. Cooling Coil Data:
- a. Identification/number
  - b. Location
  - c. Service
  - d. Manufacturer
  - e. Air flow, design and actual
  - f. Entering air DB temperature, design and actual
  - g. Entering air WB temperature, design and actual
  - h. Leaving air DB temperature, design and actual
  - i. Leaving air WB temperature, design and actual
  - j. Water flow, design and actual
  - k. Water pressure drop, design and actual
  - l. Entering water temperature, design and actual
  - m. Leaving water temperature, design and actual
  - n. Saturated suction temperature, design and actual
  - o. Air pressure drop, design and actual
11. Heating Coil Data:
- a. Identification/number
  - b. Location
  - c. Service
  - d. Manufacturer
  - e. Air flow, design and actual
  - f. Water flow, design and actual
  - g. Water pressure drop, design and actual
  - h. Entering water temperature, design and actual

- i. Leaving water temperature, design and actual
  - j. Entering air temperature, design and actual
  - k. Leaving air temperature, design and actual
  - l. Air pressure drop, design and actual
12. Air Moving Equipment:
- a. Location
  - b. Manufacturer
  - c. Model number
  - d. Serial number
  - e. Arrangement/Class/Discharge
  - f. Air flow, specified and actual
  - g. Return air flow, specified and actual
  - h. Outside air flow, specified and actual
  - i. Total static pressure (total external), specified and actual
  - j. Inlet pressure
  - k. Discharge pressure
  - l. Sheave Make/Size/Bore
  - m. Number of Belts/Make/Size
  - n. Fan RPM
13. Return Air/Outside Air Data:
- a. Identification/location
  - b. Design air flow
  - c. Actual air flow
  - d. Design return air flow
  - e. Actual return air flow
  - f. Design outside air flow
  - g. Actual outside air flow
  - h. Return air temperature
  - i. Outside air temperature
  - j. Required mixed air temperature
  - k. Actual mixed air temperature
  - l. Design outside/return air ratio
  - m. Actual outside/return air ratio
14. Exhaust Fan Data:
- a. Location
  - b. Manufacturer
  - c. Model number
  - d. Serial number
  - e. Air flow, specified and actual
  - f. Total static pressure (total external), specified and actual
  - g. Inlet pressure
  - h. Discharge pressure
  - i. Sheave Make/Size/Bore
  - j. Number of Belts/Make/Size
  - k. Fan RPM
15. Duct Traverse:
- a. System zone/branch
  - b. Duct size



- c. Area
- d. Design velocity
- e. Design air flow
- f. Test velocity
- g. Test air flow
- h. Duct static pressure
- i. Air temperature
- j. Air correction factor
- 16. Terminal Unit Data:
  - a. Manufacturer
  - b. Type, constant, variable, single, dual duct
  - c. Identification/number
  - d. Location
  - e. Model number
  - f. Size
  - g. Minimum static pressure
  - h. Minimum design air flow
  - i. Maximum design air flow
  - j. Maximum actual air flow
  - k. Inlet static pressure
- 17. Air Distribution Test Sheet:
  - a. Air terminal number
  - b. Room number/location
  - c. Terminal type
  - d. Terminal size
  - e. Area factor
  - f. Design velocity
  - g. Design air flow
  - h. Test (final) velocity
  - i. Test (final) air flow
  - j. Percent of design air flow
- 18. Sound Level Report:
  - a. Location
  - b. Octave bands - equipment off
  - c. Octave bands - equipment on
  - d. RC level - equipment on
- 19. Vibration Test:
  - a. Location of points:
    - 1) Fan bearing, drive end
    - 2) Fan bearing, opposite end
    - 3) Motor bearing, center (when applicable)
    - 4) Motor bearing, drive end
    - 5) Motor bearing, opposite end
    - 6) Casing (bottom or top)
    - 7) Casing (side)
    - 8) Duct after flexible connection (discharge)
    - 9) Duct after flexible connection (suction)

- b. Test readings:
  - 1) Horizontal, velocity and displacement
  - 2) Vertical, velocity and displacement
  - 3) Axial, velocity and displacement
- c. Normally acceptable readings, velocity and acceleration
- d. Unusual conditions at time of test
- e. Vibration source (when non-complying)

END OF SECTION

SECTION 23 08 00

COMMISSIONING

PART 1 GENERAL

1.1 SUMMARY

- A. Section Includes:
  - 1. Project commissioning description.
  - 2. Project commissioning responsibilities.
- B. Related Sections:
  - 1. Section 23 05 93 - Testing, Adjusting, and Balancing for HVAC.
  - 2. Section 23 09 00 - Instrumentation and Control for HVAC.

1.2 REFERENCES

- A. Associated Air Balance Council:
  - 1. AABC - AABC Commissioning Guideline.
- B. American Society of Heating, Refrigerating and Air-Conditioning Engineers:
  - 1. ASHRAE Guideline 1 - The HVAC Commissioning Process.
- C. National Environmental Balancing Bureau:

1.3 NEBB - Procedural Standards for Building Systems Commissioning.

1.4 COMMISSIONING DESCRIPTION

- A. Project commissioning process includes the following tasks:
  - 1. Testing and startup of cooling tower systems.
  - 2. Equipment and system verification checks.
  - 3. Assistance in functional performance testing to verify testing and balancing, and equipment and system performance.
  - 4. Provide qualified personnel to assist in commissioning tests, including seasonal testing.
  - 5. Complete and endorse functional performance test checklists provided by Commissioning Authority to assure equipment and systems are fully operational and ready for functional performance testing.
  - 6. Provide equipment, materials, and labor necessary to correct deficiencies found during commissioning process to fulfill contract and warranty requirements.
  - 7. Provide operation and maintenance information and record drawings to Commissioning Authority for review verification and organization, prior to distribution.
  - 8. Provide assistance to Commissioning Authority to develop, edit, and document system operation descriptions.

9. Provide training for systems specified in this Section with coordination by Commissioning Authority.
- B. Equipment and Systems to Be Commissioned:
1. Cooling tower system.
  2. Pumps.
  3. Piping systems.
  4. Variable frequency drives.
  5. Equipment vibration control.
  6. Automatic monitoring and control systems.
  7. Testing, Adjusting and Balancing work.
- C. Perform seasonal function performance tests for the following equipment and systems:
1. Steam system in winter.
  2. Chilled water system in summer.

#### 1.5 COMMISSIONING SUBMITTALS

- A. Draft Forms: Submit draft of system verification form and functional performance test checklist.
- B. Test Reports: Indicate data on system verification form for each piece of equipment and system as specified.
- C. Field Reports: Indicate deficiencies preventing completion of equipment or system verification checks equipment or system to achieve specified performance.

#### 1.6 CLOSEOUT SUBMITTALS

- A. Project Record Documents: Record revisions to equipment and system documentation necessitated by commissioning.
- B. Operation and Maintenance Data: Submit revisions to operation and maintenance manuals when necessary revisions are discovered during commissioning.

#### 1.7 QUALITY ASSURANCE

- A. Perform Work in accordance with AABC.

#### 1.8 COMMISSIONING RESPONSIBILITIES

- A. Equipment or System Installer Commissioning Responsibilities: (By Contractor)
1. Attend commissioning meetings.
  2. Ensure controls installer performs assigned commissioning responsibilities as specified below.
  3. Ensure testing, adjusting, and balancing agency performs assigned commissioning responsibilities as specified.
  4. Provide instructions and demonstrations for Owner's personnel.
  5. Ensure subcontractors perform assigned commissioning responsibilities.

6. Ensure participation of equipment manufacturers in appropriate startup, testing, and training activities when required by individual equipment specifications.
  7. Develop startup and initial checkout plan using manufacturer's startup procedures and functional performance checklists for equipment and systems to be commissioned.
  8. During verification check and startup process, execute Project related portions of checklists for equipment and systems to be commissioned.
  9. Perform and document completed startup and system operational checkout procedures, providing copy to Commissioning Authority.
  10. Provide manufacturer's representatives to execute starting of equipment. Ensure representatives are available and present during agreed upon schedules and are in attendance for duration to complete tests, adjustments and problem-solving.
  11. Coordinate with equipment manufacturers to determine specific requirements to maintain validity of warranties.
  12. Provide personnel to assist Commissioning Authority during equipment or system verification checks and functional performance tests.
  13. Prior to functional performance tests, review test procedures to ensure feasibility, safety and equipment protection and provide necessary written alarm limits to be used during tests.
  14. Prior to startup, inspect, check, and verify correct and complete installation of equipment and system components for verification checks included in commissioning plan. When deficient or incomplete work is discovered, ensure corrective action is taken and re-check until equipment or system is ready for startup.
  15. Provide factory supervised startup services for equipment and systems specified in Divisions 22, 23, 26, 32 & 33. Coordinate work with manufacturer and Commissioning Authority.
  16. Perform verification checks and startup on equipment and systems as specified.
  17. Assist Commissioning Authority in performing functional performance tests on equipment and systems as specified.
  18. Perform operation and maintenance training sessions scheduled by Commissioning Authority.
  19. Conduct Project system orientation and inspection.
- B. Instrumentation and Controls Installer Commissioning Responsibilities: (By Owner)
1. Attend commissioning meetings.
  2. Review design for ability of systems to be controlled including the following:
    - a. Confirm proper hardware requirements exist to perform functional performance testing.
    - b. Confirm proper safeties and interlocks are included in design.
    - c. Confirm proper sizing of system control valves and actuators and control valve operation will result capacity control identified in Contract Documents.
    - d. Confirm proper sizing of system control dampers and actuators and damper operation will result in proper damper positioning.
    - e. Confirm sensors selected are within device ranges.
    - f. Review sequences of operation and obtain clarification from Engineer.

- g. Indicate delineation of control between packaged controls and building automation system, listing BAS monitor points and BAS adjustable control points.
          - h. Provide written sequences of operation for packaged controlled equipment. Equipment manufacturers' stock sequences may be included, when accompanied by additional narrative to reflect Project conditions.
    - 3. Inspect, check, and confirm proper operation and performance of control hardware and software provided in other Project sections.
    - 4. Submit proposed procedures for performing automatic system control system point-to-point checks to Commissioning Authority and Engineer.
    - 5. Inspect check and confirm correct installation and operation of automatic temperature control system input and output device operation through point-to-point checks.
    - 6. Perform training sessions to instruct Owner's personnel in hardware operation, software operation, programming, and application in accordance with commissioning plan and requirements of Section 23 09 00.
    - 7. Demonstrate system performance and operation to Commissioning Authority during functional performance tests including each mode of operation.
    - 8. Provide control system technician to assist during Commissioning Authority verification check and functional performance testing.
    - 9. Provide control system technician to assist testing, adjusting, and balancing agency during performance of testing, adjusting, and balancing work.
    - 10. Assist in performing operation and maintenance training sessions scheduled by Commissioning Authority.
  - C. Testing, Adjusting, and Balancing Agency Commissioning Responsibilities:
    - 1. Attend commissioning meetings.
    - 2. Participate in verification of testing, adjusting, and balancing report for verification or diagnostic purposes. Repeat sample of 10 percent of measurements contained in testing, adjusting, and balancing report as selected by Commissioning Authority.
    - 3. Assist in performing operation and maintenance training sessions scheduled by Commissioning Authority.
- 1.9 COMMISSIONING MEETINGS
- A. Attend initial commissioning meeting and progress commissioning meetings as required by Commissioning Authority.
- 1.10 SCHEDULING
- A. Prepare schedule indicating anticipated start dates for the following:
    - 1. Piping system pressure testing.
    - 2. Piping system flushing and cleaning.
    - 3. Ductwork cleaning.
    - 4. Ductwork pressure testing.
    - 5. Equipment and system startups.
    - 6. Automatic control system checkout.
    - 7. Testing, adjusting, and balancing.

8. HVAC system orientation and inspections.
  9. Operation and maintenance manual submittals.
  10. Training sessions.
- B. Schedule seasonal tests of equipment and systems during peak weather conditions to observe full-load performance.
- C. Schedule occupancy sensitive tests of equipment and systems during conditions of both minimum and maximum occupancy or use.

#### 1.11 COORDINATION

- A. Notify Commissioning Authority minimum of 8 weeks in advance of the following:
1. Scheduled equipment and system startups.
  2. Scheduled automatic control system checkout.
  3. Scheduled start of testing, adjusting, and balancing work.
- B. Coordinate programming of automatic control systems with construction and commissioning schedules.

#### PART 2 PRODUCTS

Not Used.

#### PART 3 EXECUTION

##### 3.1 INSTALLATION

- A. Install additional balancing valves, and pressure and temperature taps required by Commissioning Authority.
- B. Place Project systems and equipment into full operation and continue operation during each working day of commissioning.
- C. Install replacement sheaves and belts to obtain system performance, as requested by Commissioning Authority.
- D. Install test holes in ductwork and plenums as requested by Commissioning Authority for taking air measurements.

##### 3.2 COMMISSIONING

- A. Seasonal Sensitive Functional Performance Tests:
1. Test heating equipment at winter design temperatures.
  2. Test cooling equipment at summer design temperatures.
  3. Participate in testing delayed beyond Final Completion to test performance at peak seasonal conditions.

- B. Be responsible to participate in initial and alternate peak season test of systems required to demonstrate performance.

END OF SECTION



SECTION 23 09 00  
HVAC INSTRUMENTATION AND CONTROLS  
**FOR REFERENCE ON CONTROL ELEMENTS OF THIS PROJECT**

PART 1 GENERAL

1.1 WORK INCLUDED

- A. General – Building Management System (BMS) Contractor shall provide and install:
1. A fully integrated Building Automation System (BAS), incorporating direct digital control (DDC) for energy management, equipment monitoring and control, and subsystems with open communications capabilities as herein specified.
  2. Complete temperature control system to be DDC with electric actuation as specified herein.
  3. All wiring, conduit, panels, and accessories for a complete operational system.
  4. BMS Contractor shall be responsible for all electrical work associated with the BMS.
    - a. Perform all wiring in accordance with all local and national codes.
    - b. Install all line voltage wiring, concealed or exposed, in conduit in accordance with the division 26 specifications, NEC and local building code.
    - c. Surge transient protection shall be incorporated in design of system to protect electrical components in all DDC Controllers and operator's workstations.
    - d. All systems requiring interlock wiring shall be hardwired interlocked and shall not rely on the BMS to operate (e.g. emergency generator to fuel oil pump interlock, emergency generator damper interlock, etc.) Interlock wiring shall be run in separate conduits from BMS associated wiring.
  5. All wells for water monitoring devices, flow switches and alarms, as required.
    - a. All installation kits for turbine flow meters, allow service and removal under pressure Air vents.
  6. Provide open communications system. The system shall be an open architecture with the capabilities to support a multi-vendor environment. To accomplish this effectively, system shall be capable of utilizing standard protocols as follows as well as be able to integrate third-party systems via existing vendor protocols.
    - a. System shall seamlessly integrate with the PSU campus building automation system, data acquisition system, remote notification system and historical data archiving system.
    - b. System shall be capable of high speed Ethernet communication using TCP/IP protocol.
    - c. System shall be capable of BACnet communication according to ANSI/ASHRAE 135-2004.
    - d. System shall be capable of OPC server communications according to OPC Data Access 2.0 and Alarms and Events 1.0.

- e. System shall be capable of using the LonTalk protocol.
  - f. The system shall be capable of supporting both standard and vendor specific protocols to integrate a wide variety of third-party devices and legacy systems.
  - g. The system shall be capable of supporting wireless field level networks and sensor communications using a MESH topology and IEEE 802.15.4 network.
7. Provide hardware, software, and wiring to provide communication interfaces with each of the systems listed below.
    - a. Chiller Controls
    - b. Building Steam and Chiller Water Metering
    - c. Steam System Condensate Pumping Controls
    - d. Condenser Supply Controls – Interface with Cooling Tower
  8. Provide system graphics for each controlled device and/or integrated systems as required by the owner. Origin of information shall be transparent to the operator and shall be controlled, displayed, trended, etc. as if the points were hardwired to the BMS.
- B. General Product Description:
1. The installation of the control system shall be performed under the direct supervision of the controls manufacturer with the shop drawings, bill of materials, component designation, or identification number and sequence of operation all bearing the name of the manufacturer.
  2. All materials and equipment used shall be standard components, regularly manufactured for this and/or other systems and not custom designed specially for this project.
  3. The system shall be scalable in nature and shall permit expansion of both capacity and functionality through the addition of sensors, actuators, DDC Controllers, and operator devices.
  4. System architectural design shall eliminate dependence upon any single device for alarm reporting and control execution. Each DDC Controller shall operate independently by performing its own specified control, alarm management, operator I/O, and data collection. The failure of any single component or network connection shall not interrupt the execution of any control strategy, reporting, alarming and trending function, or any function at any operator interface device.
  5. DDC Controllers shall be able to access any data from, or send control commands and alarm reports directly to any other DDC Controller or combination of controllers on the network without dependence upon a central or intermediate processing device. DDC Controllers shall also be able to send alarms to multiple operator workstations without dependence upon a central or intermediate processing device.
  6. DDC Controllers shall be able to assign password access and control priorities to each point individually. The Logon password (at any PC workstation or portable operator terminal) shall enable the operator to monitor, adjust or control only the points that the operator is authorized for. All other points shall not be displayed at the PC workstation or portable terminal. Passwords and priority levels for every point shall be fully programmable and adjustable.

## 1.2 RELATED SECTIONS

- A. The General Conditions of the Contract, Supplementary Conditions, and General Requirements are part of this specification and shall be used in conjunction with this section as part of the contract documents.
- B. The following sections constitute related work:
  - 1. Section 01010 – Summary of Work
  - 2. Section 01300 - Submittals
  - 3. Section 23 64 16 – Centrifugal Chiller
  - 4. Section 26 05 53 – Identifications for Electrical System
  - 5. Section 23 08 00 – Commissioning
  - 6. Section 23 09 93 – Sequence of Operations for HVAC

## 1.3 APPROVED CONTROL SYSTEM CONTRACTORS

- A. Approved Control System Contractor and Manufacturer:
  - 1. Siemens Building Technologies APOGEE System to match existing campus BAS.
  - 2. No other acceptable manufacturers.

## 1.4 QUALITY ASSURANCE

- A. The BAS system shall be designed and installed, commissioned and serviced by factory trained personnel. BMS contractor shall have an in-place support facility within 20 miles of the site with technical staff, spare parts inventory and necessary test and diagnostic equipment. The BMS contractor shall provide full time, on site, experienced project manager for this work, responsible for direct supervision of the design, installation, start up and commissioning of the BMS. The Bidder shall be regularly engaged in the installation and maintenance of BMS systems and shall have a minimum of ten (10) years of demonstrated technical expertise and experience in the installation and maintenance of BMS systems similar in size and complexity to this project.
- B. Materials and equipment shall be the catalogued products of manufacturers regularly engaged in production and installation of automatic temperature control systems and shall be manufacturer's latest standard design that complies with the specification requirements.
- C. All electronic equipment shall conform to the requirements of FCC Regulation, Part 15, Governing Radio Frequency Electromagnetic Interference and be so labeled.
- D. The manufacturer of the building automation system shall provide documentation supporting compliance with ISO-9002 (Model for Quality Assurance in Production, Installation, and Servicing) and ISO-14001 (The application of well-accepted business management principles to the environment).
- E. This system shall have a documented history of compatibility by design for a minimum of 15 years. Future compatibility shall be supported for no less than 10 years. Compatibility shall be defined as the ability to upgrade existing field panels to current level of technology, and extend new field panels on a previously installed network.

Compatibility shall be defined as the ability for any existing field panel microprocessor to be connected and directly communicate with new field panels without bridges, routers or protocol converters.

## 1.5 CODES AND STANDARDS

- A. Work, materials, and equipment shall comply with the most restrictive of local, state, and federal authorities' codes and ordinances or these plans and specifications. As a minimum, the installation shall comply with current editions in effect 30 days prior to receipt of bids of the following codes:
1. National Electric Code (NEC)
  2. Uniform Building Code (UBC)
  3. Uniform Mechanical Code (UMC)
  4. ANSI/ASHRAE Standard 135- 2004, BACnet- Data Communication Protocol for Building Automation and Control Networks

## 1.6 SUBMITTALS

- A. Product Submittal Requirements. Provide six copies of shop drawings and other submittals on hardware, software, and equipment to be installed or furnished. Begin no work until submittals have been approved for conformity with design intent. Provide drawings as AutoCAD 2008 (or newer) compatible files on optical disk or hard copies on 11" x 17" prints of each drawing. When manufacturer's specification sheets apply to a product series rather than a specific product, clearly indicate applicable data by highlighting or by other means.
- B. Provide submittals within 12 weeks of contract award (project specific)
- C. Submittal data shall consist of the following:
1. Direct Digital Control System Hardware:
    - a. Complete bill of materials indicating quantity, manufacturer, model number, and relevant technical data of equipment to be used.
    - b. Manufacturer's description and technical data, such as product specification sheets, installation and maintenance instructions for items listed below and for relevant items not listed below:
      - 1) Direct Digital Controllers (controller panels)
      - 2) Transducers and transmitters
      - 3) Sensors (including accuracy data)
      - 4) Valves
      - 5) Dampers
      - 6) Relays and Switches
      - 7) Control Panels
      - 8) Power Supplies
      - 9) Operator Interface Equipment
    - c. Wiring diagrams and layouts for each control panel. Show all termination numbers.
    - d. Floor plan schematic diagrams indicating control panel and space temperature sensor locations.

2. Central System Hardware and Software:
  - a. Complete bill of material indicating quantity, manufacturer, model number, and relevant technical data of equipment used.
  - b. Manufacturer's description and technical data such as product specifications for items listed below and for relevant items furnished under this contract not listed below:
    - 1) Central Processing Unit (CPU)
    - 2) Monitors
    - 3) Keyboards
    - 4) Power Supply
    - 5) Battery Backup
    - 6) Interface Equipment Between CPU and Control Panels
    - 7) Operating System Software
    - 8) Operator Interface Software
    - 9) Color Graphic Software
    - 10) Third-Party Software
  - c. Schematic diagrams of all control, communication, and power wiring for central system installation. Show interface wiring to control system.
  - d. Provide a list of BMS point naming convention. Indicate format, structure and standards of typical point names. Follow PSU's established point naming convention for the Siemens APOGEE network.
3. Controlled Systems:
  - a. Riser diagrams showing control network layout, communication protocol, and wire types.
  - b. Schematic diagram of each controlled system. Label control points with point names. Graphically show locations of control elements.
  - c. Schematic wiring diagram of each controlled system. Label control elements and terminals. Where a control element is also shown on control system schematic use the same name.
  - d. Instrumentation list for each controlled system. List control system element in a table. Show element name, type of device, manufacturer, model number, and product data sheet number.
  - e. Complete description of control system operation including sequences of operation. Include and reference schematic diagram of controlled system.
  - f. Point list for each system controller including both inputs and outputs (I/O), point numbers, controlled device associated with each I/O point, and location of I/O device.
4. Description of process, report formats and checklists to be used in Part 3: "Control System Demonstration and Acceptance."
5. Contractor shall submit documentation in the following phased delivery schedule:
  - a. Valve and damper schedules
  - b. Point Naming Convention
  - c. Sample Graphics
  - d. System schematics, including:

- 1) System Riser Diagrams
  - 2) Sequence of Operations
  - 3) Mechanical Control Schematics
  - 4) Electrical Wiring Diagrams
  - 5) Control Panel Layouts
  - 6) Product Specification Sheets
- e. As-Built drawings
- D. Project Record Documents: Submit three copies of record (as-built) documents upon completion of installation. Submittal shall consist of:
1. Project Record Drawings. As-built versions of the submittal shop drawings provided as AutoCAD 2004 (or newer) compatible files on optical media and as 11" x 17" prints.
  2. Testing and Commissioning Reports and Checklists. Completed versions of reports, checklists, and trend logs used to meet requirements of Part 3: "Control System Demonstration and Acceptance."
  3. Operation and Maintenance (O & M) Manual.
    - a. As-built versions of the submittal product data.
    - b. Operator's Manual with procedures for operating control systems, logging on and off, handling alarms, producing point reports, trending data, overriding computer control, and changing set points and variables.
    - c. Programming manual or set of manuals with description of programming language and of statements for algorithms and calculations used, of point database creation and modification, of program creation and modification, and of editor use.
    - d. Documentation of all programs created using custom programming language, including set points, tuning parameters, and object database.
    - e. Graphic files, programs, and database on magnetic or optical media.
    - f. List of recommended spare parts with part numbers and suppliers.
    - g. Complete original-issue documentation, installation, and maintenance information for furnished third-party hardware, including computer equipment and sensors.
    - h. Complete original original-issue copies of furnished software, including operating systems, custom programming language, operator workstation software, and graphics software.
    - i. Licenses, guarantees, and warranty documents for equipment and systems.

## 1.7 WARRANTY

- A. Warrant labor and materials for specified control system free from defects for a period of 12 months after final acceptance. Failures on control systems that include all computer equipment, transmission equipment and all sensors and control devices during warranty period shall be adjusted, repaired, or replaced at no additional cost or reduction in service to Owner. Respond during normal business hours within 24 hours of Owner's warranty service request.

- B. Work shall have a single warranty date, even if Owner receives beneficial use due to early system start-up. If specified work is split into multiple contracts or a multi-phase contract, each contract or phase shall have a separate warranty start date and period.
- C. If Engineer determines that equipment and systems operate satisfactorily at the end of final start-up, testing, and commissioning phase, Engineer will certify in writing that control system operation has been tested and accepted in accordance with the terms of this specification. Date of acceptance shall begin warranty period.
- D. Provide updates to operator workstation software, project-specific software, graphic software, database software, and firmware that resolve Contractor identified software deficiencies at no charge during warranty period. If available, Owner can purchase in-warranty service agreement to receive upgrades for functional enhancements associated with the above-mentioned items.
- E. Contractor shall not be required to warrant reused devices, except those that have been rebuilt or repaired. Installation labor and materials shall be warranted. Demonstrate operable condition of reused devices at time of Engineer's acceptance.
- F. Contractor shall not be required to warrant systems, equipment and devices or software if the damages and/or failures were caused by lack of training, unauthorized use, negligence or deliberate action of other parties, or job site conditions.

#### 1.8 OWNERSHIP OF PROPRIETARY MATERIAL

- A. Project specific software and documentation shall become Owner's property. This includes, but not limited to:
  - 1. Graphics
  - 2. Record drawings
  - 3. Database
  - 4. Application programming code
- B. Documentation
  - 1. General
    - a. Submit two (2) electronic copies of complete as-built documentation on CD ROM. All drawings shall be in standard AutoCad 2004 format, other documentation shall be in standard MS Office format.
    - b. Update manuals with modifications made to system during guarantee period. Provide replacement pages or supplements in quantity stated above for "as built" manuals.
    - c. Assemble owner's manuals into multi-volume sets as necessary and required by the owner.
    - d. Protect each volume with a heavy duty binder. Volumes to have plastic printed dividers between major sections and have oversized binders to accommodate up to ½ inch thick set of additional information.
    - e. Each binder to be printed with project name and volume title on front cover and binder.
    - f. On the first page of each manual identify with project name, manual title, owner's name, engineer's name, contractor's name, address and service phone number, and person who prepared manual.



- C. Operating manual to serve as training and reference manual for all aspects of day-to-day operation of the system. As a minimum include the following:
  - 1. Sequence of operation for automatic and manual operating modes for all building systems. The sequences shall cross reference the system point names.
  - 2. Description of manual override operation of all control points in system.
  - 3. BMS system manufacturers complete operating manuals.
  
- D. Provide Programming Manual to serve as training and reference manual for all aspects of system programming. As a minimum include the following:
  - 1. Complete programming manuals, and reference guides.
  - 2. Details of any custom software packages and compilers supplied with system.
  - 3. Information and access required for independent programming of system.

## PART 2 PRODUCTS

### 2.1 MATERIALS

- A. All products used in this project installation shall be new and currently manufactured and shall have been applied in similar installations. Do not use this installation as a product test site unless explicitly approved in writing by Owner or Owner's representative. Spare parts shall be available for at least five years after completion of this contract.
  
- B. Auxiliary Control Devices: See also Instrumentation List/Matrix, Drawing J0.3.

### 2.2 COMMUNICATION

- A. The design of the BMS shall support networking of operator workstations and Building Controllers. The network architecture shall consist of two levels, an Ethernet based primary network for all operator workstations, servers, and primary DDC controllers along with secondary Floor Level Networks (FLN) for terminal equipment application specific controllers.
  
- B. Access to system data shall not be restricted by the hardware configuration of the building management system. The hardware configuration of the BMS network shall be totally transparent to the user when accessing data or developing control programs.
  
- C. Operator Workstation Communication:
  - 1. All color graphic operator workstations shall reside on the Ethernet network and the consoles shall be set up in a client/server configuration.
  - 2. The servers will act as the central database for system graphics and databases to provide consistency throughout all system workstations.
  - 3. The network shall allow concurrent use of multiple BMS software site licenses.
  
- D. Management Level Network Communication (MLN)
  - 1. All PCs shall simultaneously direct connect to the Ethernet Management Level Network without the use of an interposing device.
  - 2. Operator Workstation shall be capable of simultaneous direct connection and communication with BACnet/IP, OPC and TCP/IP corporate level networks without the use of interposing devices.



3. The Management Level Network shall not impose a maximum constraint on the number of operator workstations.
4. Any controller residing on the primary building level networks shall connect to Ethernet network without the use of a PC or a gateway with a hard drive.
5. Any PC on the Management Level Network shall have transparent communication with controllers on the building level networks connected via Ethernet.
6. Any break in Ethernet communication from the PC to the controllers on the building level networks shall result in a notification at the PC.
7. The standard client and server workstations on the Management Level Network shall reside on industry standard Ethernet utilizing standard TCP/IP, IEEE 802.3.
8. System software applications will run as a service to allow communication with Primary Network Controllers without the need for user log in. Closing the application or logging off shall not prevent the processing of alarms, network status, panel failures, and trend information.
9. Any break in Ethernet communication between the standard client and server workstations on the Management Level Network shall result in a notification at each workstation.
10. Access to the system database shall be available from any standard client workstation on the Management Level Network.

E. Primary Network - Panel to Panel Communication:

1. All Building Controllers shall directly reside on the primary Ethernet network such that communications may be executed directly between Building Controllers, directly between server and Building Controllers on a peer-to-peer basis.
2. Systems that operate via polled response or other types of protocols that rely on a central processor, file server, or similar device to manage panel-to-panel or device-to-device communications shall not be acceptable.
3. All operator interfaces shall have the ability to access all point status and application report data or execute control functions for any and all other devices. Access to data shall be based upon logical identification of building equipment. No hardware or software limits shall be imposed on the number of devices with global access to the network data.
4. The primary network shall use TCP/IP over Ethernet. All devices must:
  - a. Auto-sense 10/100 Mbps networks.
  - b. Receive an IP Address from a Dynamic Host Configuration Protocol (DHCP) Server or be configured with a Fixed IP Address.
  - c. Resolve Name to IP Addresses for devices using a Domain Name Service (DNS) Server on the Ethernet network.
  - d. Allow MMI access to an individual Primary Network Controller using industry standard Telnet software to view and edit entire Primary Network.
5. The primary network shall provide the following minimum performance:
  - a. Provide high-speed data transfer rates for alarm reporting, report generation from multiple controllers and upload/download efficiency between network devices. System performance shall insure that an alarm

- occurring at any Building Controller is displayed at any PC workstations, all Building controllers, and other alarm printers within 15 seconds.
- b. Message and alarm buffering to prevent information from being lost.
  - c. Error detection, correction, and re-transmission to guarantee data integrity.
  - d. Synchronization of real-time clocks between Building Controllers, including automatic daylight savings time corrections.
  - e. The primary network shall allow the Building Controllers to access any data from, or send control commands and alarm reports directly to, any other Building Controller or combination of controllers on the network without dependence upon a central or intermediate processing device. Building Controllers shall send alarm reports to multiple operator workstations without dependence upon a central or intermediate processing device. The network shall also allow any Building controller to access, edit, modify, add, delete, back up, restore all system point database and all programs.
  - f. The primary network shall allow the Building Controllers to assign password access and control priorities to each point individually. The logon password (at any PC workstation or portable operator terminal) shall enable the operator to monitor, adjust and control only the points that the operator is authorized for. All other points shall not be displayed at the PC workstation or portable terminal. (e.g. all base building and all tenant points shall be accessible to any base building operators, but only certain base building and tenant points shall be accessible to tenant building operators). Passwords and priorities for every point shall be fully programmable and adjustable.
  - g. Devices containing custom programming must reside on the Primary Network
- F. Secondary Network – Application Specific Controller Communication:
- 1. Communication over the secondary network shall be the manufacturer's standard protocol.
  - 2. This level communication shall support a family of application specific controllers for terminal equipment and shall support wireless communication capability.
  - 3. The Application Specific Controllers shall communicate bi-directionally with the primary network through Building Controllers for transmission of global data.
  - 4. A maximum of 30 terminal equipment controllers may be configured on individual secondary network trunks to insure adequate global data and alarm response times.
  - 5. Wireless communication over the secondary network shall utilize a wireless MESH topology based on an IEEE 802.15.4 network. Point to point communication shall not be unacceptable.
  - 6. Wireless communications shall take place using modular wireless transceivers at each device that eliminate the need for a physical network communication cable.
- G. Remote Notification Paging System:
- 1. Workstations shall be configured to send out messages to numeric pagers, alphanumeric pagers, phones (via text to speech technology), SMS (Simple

- Messaging Service, text messaging) Devices, and email accounts based on a point's alarm condition.
2. There shall be no limit to the number of points that can be configured for remote notification of alarm conditions and no limit on the number of remote devices which can receive messages from the system.
  3. On a per point basis, system shall be configurable to send messages to an individual or group and shall be configurable to send different messages to different remote devices based on alarm message priority level.
  4. Remote devices may be scheduled as to when they receive messages from the system to account for operators' work schedules.
  5. System must be configurable to send messages to an escalation list so that if the first device does not respond, the message is sent on to the next device after a configurable time has elapsed.
  6. Message detail shall be configurable on a per user basis.
  7. During a "flood" of alarms, remote notification messages shall have the ability to optimize several alarms into an individual remote notification message.
  8. Workstation shall have the ability to send manual messages allowing an operator to type in a message to be sent immediately.
  9. Workstation shall have a feature to send a heartbeat message to periodically notify users that they have communication with the system.

### 2.3 OPERATOR INTERFACE

- A. Workstation hardware:
1. Personal computer operator workstations shall be provided for command entry, information management, system monitor, alarm management and database management functions. All real-time control functions shall be resident in the Building Controllers to facilitate greater distribution, fault tolerance and reliability of the building automation control.
    - a. Provide workstation(s) of equal capability as located on plans.
    - b. Workstation shall consist of a personal computer with minimum 512MB RAM, hard drive with 80 GB available space, video card with 64 MB RAM capable of supporting a minimum of 1280 × 1024 resolution with a minimum of 32 Bit color, CD-RW, and DVD-ROM Drive, mouse and 101-key enhanced keyboard. Personal computer shall be a Windows XP, 2000 or comparable operating system and shall include a minimum 3.0 GHz Pentium processor.
    - c. The PC monitor shall be of flat panel type and shall support a minimum display resolution of no less than 1280 × 1024 pixels. The display shall have a minimum of 17" visible area in diagonal measurement. Separate controls shall be provided for color, contrasts and brightness. The screen shall be non-reflective.
    - d. Provide an Epson FX-870 or equivalent printer at each workstation location or on the network (Ethernet) for recording alarms, operator transactions and systems reports.
    - e. Alarm Display shall list the alarms with highest priority at the top of the display. The alarm display shall provide selector buttons for display of the associated point graphic and message. The alarm display shall provide a mechanism for the operator to sort alarms.

- B. Operator Interface Software:
1. Basic Interface Description
    - a. Operator interface software shall minimize operator training through the use of user-friendly and interactive graphical applications, 30-character English language point identification, on-line help, and industry standard Windows application software. Interface software shall simultaneously communicate with and share data between Ethernet-connected building level networks.
    - b. Provide a graphical user interface that shall minimize the use of keyboard through the use of a mouse or similar pointing device, with a "point and click" approach to menu selection and a "drag and drop" approach to inter-application navigation.
    - c. The navigation shall be user friendly by utilizing "forward & back" capability between screens and embedded hyperlinks to open graphics, documents, drawings, etc.
    - d. Selection of applications within the operator interface software shall be via a graphical toolbar menu – the application toolbar menu shall have the option to be located in a docked position on any of the four sides of the visible desktop space on the workstation display monitor, and the option to automatically hide itself from the visible monitor workspace when not being actively manipulated by the user.
    - e. The software shall provide a multi-tasking type environment that allows the user to run several applications simultaneously. BMS software shall run on a Windows XP, 2000, or comparable 32 bit operating system. System database parameters shall be stored within an object-oriented database. Standard Windows applications shall run simultaneously with the BMS software. The mouse or Alt-Tab keys shall be used to quickly select and switch between multiple applications. The operator shall be able to work in Microsoft Word, Excel, and other Windows based software packages, while concurrently annunciating on-line BMS alarms and monitoring information
    - f. The software shall provide, as a minimum, the following functionality:
      - 1) Real-time graphical viewing and control of the BMS environment.
      - 2) Reporting
      - 3) Scheduling and override of building operations
      - 4) Collection and analysis of historical data
      - 5) Point database editing, storage and downloading of controller databases.
      - 6) Utility for combining points into logical Point Groups. The graphs and reports in order to streamline the navigation and usability of the system.
      - 7) Alarm reporting, routing, messaging, and acknowledgment
      - 8) "Collapsible tree," dynamic system architecture diagram application :
        - a) Showing the real-time status and definition details of all workstations and devices on a management level network

- b) Showing the real-time status and definition details of all Building Controllers at the Primary Network.
  - c) Showing the definition details of all application specific controllers
- 9) Definition and construction of dynamic color graphic displays.
  - 10) Online, context-sensitive help, including an index, glossary of terms, and the capability to search help via keyword or phrase.
  - 11) On-screen access to User Documentation, via online help or PDF-format electronic file.
  - 12) Automatic database backup at the operator interface for database changes initiated at Building Controllers.
  - 13) Display dynamic trend data graphical plot.
    - a) Must be able to run multiple plots simultaneously
    - b) Each plot must be capable of supporting 10 pts/plot minimum
    - c) Must be able to command points directly off dynamic trend plot application.
    - d) Must be able to plot both real-time and historical trend data
  - 14) Program editing
  - 15) Transfer trend data to 3rd party spreadsheet software
    - a) Scheduling reports
    - b) Operator Activity Log
    - c) Open communications via BACnet Client & Server
- g. Enhanced Functionality:
- 1) Provide functionality such that any of the following may be performed simultaneously on-line, and in any combination, via adjustable user-sized windows. Operator shall be able to drag and drop information between the following applications, reducing the number of steps to perform a desired function (e.g., Click on a point on the alarm screen and drag it to the dynamic trend graph application to initiate a dynamic trend on the desired point):
    - a) Dynamic color graphics application
    - b) Alarm management application
    - c) Scheduling application
    - d) Dynamic trend graph data plotter application
    - e) Dynamic system architecture diagram application
    - f) Control Program and Point database editing applications
    - g) Reporting applications
  - 2) Report and alarm printing shall be accomplished via Windows Print Manager, allowing use of network printers.
- h. Security: Operator-specific password access protection shall be provided to allow the administrator/manager to limit users' workstation control,

display and data base manipulation capabilities as deemed appropriate for each user, based upon an assigned password. Operator privileges shall "follow" the operator to any workstation logged onto (up to 999 user accounts shall be supported). The administrator or manager shall be able to grant discrete levels of access and privileges, per user, for each point, graphic, report, schedule, and BMS workstation application. And each BMS workstation user account shall use a Windows Operating System user account as a foundation.

- i. The operator interface software shall also include an application to track the actions of each individual operator, such as alarm acknowledgement, point commanding, schedule overriding, database editing, and logon/logoff. The application shall list each of the actions in a tabular format, and shall have sorting capabilities based on parameters such as ascending or descending time of the action, or name of the object on which the action was performed. The application shall also allow querying based on object name, operator, action, or time range.
- j. Dynamic Color Graphics application shall include the following:
  - 1) Must include graphic editing and modifying capabilities
  - 2) A library of standard control application graphics and symbols must be included
  - 3) Must be able to command points directly off graphics application
  - 4) Graphic display shall include the ability to depict real-time point values dynamically with animation, picture/frame control, symbol association, or dynamic informational text-blocks
  - 5) Navigation through various graphic screens shall be optionally achieved through a hierarchical "tree" structure
  - 6) Graphics viewing shall include zoom capabilities
  - 7) Graphics shall be capable of displaying the status of points that have been overridden by a field HAND switch, for points that have been designed to provide a field HAND override capability.
  - 8) Advanced linking within the Graphics application shall provide the ability to navigate to outside documents (e.g., .doc, .pdf, .xls, etc.), Internet web addresses, e-mail, external programs, and other workstation applications, directly from the Graphics application window with a mouse-click on a customizable link symbol.
- k. Reports shall be generated on demand or via pre-defined schedule, and directed to CRT displays, printers or file. As a minimum, the system shall allow the user to easily obtain the following types of reports:
  - 1) A general listing of all or selected points in the network
  - 2) List of all points currently in alarm
  - 3) List of all points currently in override status
  - 4) List of all disabled points
  - 5) List of all points currently locked out
  - 6) List of user accounts and access levels
  - 7) List all weekly schedules and events
  - 8) List of holiday programming
  - 9) List of control limits and deadbands



- 10) Custom reports from 3rd party software
  - 11) System diagnostic reports including, list of Building panels on line and communicating, status of all Building terminal unit device points
  - 12) List of programs
  - 13) List of point definitions
  - 14) List of logical point groups
  - 15) List of alarm strategy definitions
  - 16) List of Building Control panels
  - 17) Point totalization report
  - 18) Point Trend data listings
  - 19) Initial Values report
  - 20) User activity report
- l. Scheduling and Override
- 1) Provide a calendar type format for simplification of time and date scheduling and overrides of building operations. Schedule definitions reside in the PC workstation and in the Building Controller to ensure time equipment scheduling when PC is off-line, PC is not required to execute time scheduling. Provide override access through menu selection, graphical mouse action or function key. Provide the following capabilities as a minimum:
    - a) Weekly schedules
    - b) Zone schedules
    - c) Event schedules – an event consists of logical combinations of equipment and/or zones
    - d) Report schedules
    - e) Ability to schedule for a minimum of up to ten (10) years in advance.
  - 2) Additionally, the scheduling application shall:
    - a) Provide filtering capabilities of schedules, based on name, time, frequency, and schedule type (event, zone, report)
    - b) Provide sorting capabilities of schedules, based on name, time and type of schedule (zone, event, report)
    - c) Provide searching capabilities of schedules based on name – with wildcarding options
- m. Collection and Analysis of Historical Data
- 1) Provide trending capabilities that allow the user to easily monitor and preserve records of system activity over an extended period of time. Any system point may be trended automatically at time-based intervals (up to four time-based definitions per point) or change of value, both of which shall be user-definable. Trend data shall be collected stored on hard disk for future diagnostics and reporting. Automatic Trend collection may be scheduled at

regular intervals through the same scheduling interface as used for scheduling of zones, events, and reports. Additionally, trend data may be archived to network drives or removable disk media for future retrieval.

- 2) Trend data reports shall be provided to allow the user to view all trended point data. Reports may be customized to include individual points or predefined groups of selected points. Provide additional functionality to allow predefined groups of up to 250 trended points to be easily transferred on-line to Microsoft Excel. BMS contractor shall provide custom designed spreadsheet reports for use by the owner to track energy usage and cost, equipment run times, equipment efficiency, and/or building environmental conditions. BMS contractor shall provide setup of custom reports including creation of data format templates for monthly or weekly reports.
- 3) Provide additional functionality that allows the user to view real-time trend data on trend graphical plot displays. A minimum of ten points may be plotted, of either real-time or historical data. The dynamic graphs shall continuously update point values. At any time the user may redefine sampling times or range scales for any point. In addition, the user may pause the display and take "snapshots" of plot screens to be stored on the workstation disk for future recall and analysis. Exact point values may be viewed and the graphs may be printed. A minimum of ten (10) dynamic graphs shall run simultaneously. Operator shall be able to command points directly on the trend plot by double clicking on the point. Operator shall be able to zoom in on a specific time range within a plot. The dynamic trend plotting application shall support the following types of graphs, with option to graph in 3D: line graph, area graph, curve graph, area-curve graph, step graph, and scatter graph. Each graph may be customized by the user, for graph type, graph text, titles, line styles and weight, colors, and configurable x- and y-axes.

n. Dynamic Color Graphic Displays

- 1) Capability to create color graphic floor plan displays and system schematics for each piece of mechanical equipment, including, but not limited to, air handling units, chilled water systems, hot water boiler systems, and room level terminal units.
- 2) The operator interface shall allow users to access the various system schematics and floor plans via a graphical penetration scheme, menu selection, point alarm association, or text-based commands. Graphics software shall permit the importing of Autocad or scanned pictures for use in the system.
- 3) Dynamic temperature values, humidity values, flow values and status indication shall be shown in their actual respective locations within the system schematics or graphic floor plan displays, and shall automatically update to represent current



conditions without operator intervention and without pre-defined screen refresh rates.

- a) Provide the user the ability to display real-time point values by animated motion or custom picture control visual representation. Animation shall depict movement of mechanical equipment, or air or fluid flow. Picture Control shall depict various positions in relation to assigned point values or ranges. A library (set) of animation and picture control symbols shall be included within the operator interface software's graphics application. Animation shall reflect, ON or OFF conditions, and shall also be optionally configurable for up to five rates of animation speed.
  - b) Sizable analog bars shall be available for monitor and control of analog values; high and low alarm limit settings shall be displayed on the analog scale. The user shall be able to "click and drag" the pointer to change the setpoint.
  - c) Provide the user the ability to display blocks of point data by defined point groups; alarm conditions shall be displayed by flashing point blocks.
  - d) Equipment state or values can be changed by clicking on the associated point block or graphic symbol and selecting the new state (on/off) or setpoint.
  - e) State text for digital points can be user-defined up to eight characters.
- 4) Colors shall be used to indicate status and change as the status of the equipment changes. The state colors shall be user definable.
  - 5) Advanced linking within the Graphics application shall provide the ability to navigate to outside documents (e.g., .doc, .pdf, .xls, etc.), Internet web addresses, e-mail, external programs, and other workstation applications, directly from the Graphics application window with a mouse-click on a customizable link symbol.
  - 6) The Windows environment of the PC operator workstation shall allow the user to simultaneously view several applications at a time to analyze total building operation or to allow the display of a graphic associated with an alarm to be viewed without interrupting work in progress.
  - 7) Off the shelf graphic software shall be provided to allow the user to add, modify or delete system graphic background displays.
  - 8) A clipart library of HVAC application and automation symbols shall be provided including fans, valves, motors, chillers, AHU systems, standard ductwork diagrams and laboratory symbols. The user shall have the ability to add custom symbols to the clipart library. The clipart library shall include a minimum of 400 application symbols. In addition, a library consisting of a

- minimum of 700 graphic background templates shall be provided.
- 9) The Graphics application shall include a set of standard Terminal Equipment controller application-specific background graphic templates. Templates shall provide the automatic display of a selected Terminal Equipment controller's control values and parameters, without the need to create separate and individual graphic files for each controller.
- o. System Configuration & Definition
- 1) A "Collapsible tree," dynamic system architecture diagram/display application of the site-specific BMS architecture showing status of controllers, PC workstations and networks shall be provided. This application shall include the ability to add and configure workstations, Building Controllers, as well as 3rd-party integrated components. Symbols/Icons representing the system architecture components shall be user-configurable and customizable, and a library of customized icons representing 3rd-party integration solutions shall be included. This application shall also include the functionality for real-time display, configuration and diagnostics connections to Building Controllers.
  - 2) Network wide control strategies shall not be restricted to a single Building Controller, but shall be able to include data from any and all other network panels to allow the development of Global control strategies.
  - 3) Provide automatic backup and restore of all Building controller databases on the workstation hard disk. In addition, all database changes shall be performed while the workstation is on-line without disrupting other system operations. Changes shall be automatically recorded and downloaded to the appropriate Building Controller. Changes made at the user-interface of Building Controllers shall be automatically uploaded to the workstation, ensuring system continuity.
  - 4) System configuration, programming, editing, graphics generation shall be performed on-line.
  - 5) Point database configuration shall be available to the user within a dedicated point database editor application included in the operator interface software. The editor shall allow the user to create, view existing, modify, copy, and delete points from the database.
  - 6) The point editor shall have the capability to assign "informational text" to points as necessary to provide critical information about the equipment.
  - 7) The point editor shall also allow the user to configure the alarm management strategy for each point. The editor shall provide the option for editing the point database in an online or offline mode with the Building Controllers.

- 8) The operator interface software shall also provide the capability to perform bulk modification of point definition attributes to a single or multiple user-selected points. This function shall allow the user to choose the properties to copy from a selected point to another point or set of points. The selectable attributes shall include, but are not limited to, Alarm management definitions and Trend definitions.
  - 9) Control program configuration shall be available to the user within a dedicated control program editor application included in the operator interface software. The editor shall allow for creation, modification and deletion of control programs. The editor shall include a programming assistance feature that interactively guides the user through parameters required to generate a control program. The editor shall also include the ability to automatically compile the program to ensure its compatibility with the Building Controllers. The editor shall provide the option for editing the control programs in an online or offline mode, and also the ability to selectively enable or disable the live program execution within the Building Controllers.
- p. Alarm Management
- 1) Alarm Routing shall allow the user to send alarm notification to selected printers or workstation location(s) based on time of day, alarm severity, or point type.
  - 2) Alarm Notification shall be presented to each workstation in a tabular format application, and shall include the following information for each alarm point: name, value, alarm time & date, alarm status, priority, acknowledgement information, and alarm count. Each alarm point or priority shall have the ability to sound a discrete audible notification.
  - 3) Alarm Display shall have the ability to list & sort the alarms based on alarm status, point name, ascending or descending alarm time.
  - 4) Directly from the Alarm Display, the user shall have the ability to acknowledge, silence the alarm sound, print, or erase each alarm. The interface shall also have the option to inhibit the erasing of active acknowledged alarms, until they have returned to normal status. The user shall also have the ability to command, launch an associated graphic or trended graphical plot, or run a report on a selected alarm point directly on the Alarm Display.
  - 5) Each alarm point shall have a direct link from the Alarm Display to further user-defined point informational data. The user shall have the ability to also associate real-time electronic annotations or notes to each alarm.
  - 6) Alarm messages shall be customizable for each point, or each alarm priority level, to display detailed instructions to the user regarding actions to take in the event of an alarm. Alarm

messages shall also have the optional ability to individually enunciate on the workstation display via a separate pop-up window, automatically being generated as the associated alarm condition occurs. The system shall have the ability to modify the priority text based on operator preference.

- 7) Alarm Display application shall allow workstation operators to send and receive real-time messages to each other, for purposes of coordinating Alarm and BMS system management.

## 2.4 BUILDING CONTROLER SOFTWARE

### A. General:

1. Furnish the following applications software to form a complete operating system for building and energy management as described in this specification. The software programs specified in this Section shall be provided as an integral part of Building Controllers and shall not be dependent upon any higher level computer or another controller for execution.
2. All points, panels and programs shall be identified by a 30 character name. All points shall also be identified by a 16 character point descriptor. The same names shall be displayed at both Building Controller and the Operator Interface.
3. All digital points shall have a user defined two-state status indication with 8 characters minimum (e.g. Summer, Enabled, Disabled, Abnormal).
4. Building Controllers shall have the ability to perform energy management routines including but not limited to time of day scheduling, calendar-based scheduling, holiday scheduling, temporary schedule overrides, start stop time optimization, automatic daylight savings time switch over, night setback control, enthalpy switch over, peak demand limiting, temperature-compensated duty cycling, heating / cooling interlock, supply temperature reset, priority load shedding, and power failure restart.
5. The Building Controllers shall have the ability to perform the following pre tested control algorithms:
  - a. Two position control
  - b. Proportional control
  - c. Proportional plus integral control
  - d. Proportional, integral, plus derivative control
  - e. Automatic tuning of control loops
6. Each controller shall be provided with an interactive HELP function to assist operators using POTs and remote connected operators.
7. Building Controllers shall not be succceptible to Microsoft Windows operating systems based viruses.

### B. System Security

1. User access shall be secured using individual security passwords and user names.
2. Passwords shall restrict the user to the objects, applications, and system functions as assigned by the system manager.
3. User Log On / Log Off attempts shall be recorded.
4. The system shall protect itself from unauthorized use by automatically logging off following the last keystroke. The delay time shall be user-definable.

5. Use of workstation resident security as the only means of access control is not an acceptable alternative to resident system security in the field panel.
- C. User Defined Control Applications:
1. Controllers shall be able to execute custom, job-specific processes defined by the user, to automatically perform calculations and special control routines.
  2. It shall be possible to use any system measured point data or status, any system calculated data, a result from any process, or any user-defined constant in any controller in the system.
  3. Any process shall be able to issue commands to points in any and all other controllers in the system.
  4. Processes shall be able to generate operator messages and advisories to other operator I/O devices. A process shall be able to directly send a message to a specified device or cause the execution of a dial-up connection to a remote device such as a printer or pager.
  5. Each controller shall support plain language text comment lines in the operating program to allow for quick troubleshooting, documentation, and historical summaries of program development.
  6. Controller shall provide a HELP function key, providing enhanced context sensitive on-line help with task oriented information from the user manual.
- D. Alarm Management:
1. Alarm management shall be provided to monitor and direct alarm information to operator devices. Each Building Controller shall perform distributed, independent alarm analysis and filtering to minimize operator interruptions due to non-critical alarms, minimize network traffic and prevent alarms from being lost. At no time shall the Building Controllers ability to report alarms be affected by either operator or activity at a PC workstation, local I/O device or communications with other panels on the network.
  2. Conditional alarming shall allow generation of alarms based upon user defined multiple criteria.
  3. An Alarm “shelving” feature shall be provided to disable alarms during testing. (Pull the Plug, etc.).
  4. Binary Alarms. Each binary object shall be set to alarm based on the operator-specified state. Provide the capability to automatically and manually disable alarming.
  5. Analog Alarms. Each analog object shall have both high and low alarm limits. Alarming must be able to be automatically and manually disabled.
  6. All alarm or point change reports shall include the point's user defined language description and the time and date of occurrence.
  7. The user shall be able to define the specific system reaction for each point. Alarms shall be prioritized to minimize nuisance reporting and to speed operator response to critical alarms. A minimum of six priority levels shall be provided for each point. Point priority levels shall be combined with user definable destination categories (PC, printer, Building Controller, etc.) to provide full flexibility in defining the handling of system alarms. Each Building Controller shall automatically inhibit the reporting of selected alarms during system shutdown and start-up. Users shall have the ability to manually inhibit alarm reporting for each point.

8. Alarm reports and messages shall be routed to user-defined list of operator workstations, or other devices based on time and other conditions. An alarm shall be able to start programs, print, be logged in the event log, generate custom messages, and display graphics.
  9. In addition to the point's descriptor and the time and date, the user shall be able to print, display or store a 200 character alarm message to more fully describe the alarm condition or direct operator response.
    - a. Each Building Controller shall be capable of storing a library of at least 50 alarm messages. Each message may be assignable to any number of points in the Controller.
  10. Operator-selected alarms shall be capable of initiating a call to a remote operator device.
- E. Scheduling:
1. Provide a comprehensive menu driven program to automatically start and stop designated object or group of objects in the system according to a stored time.
  2. Schedules shall reside in the building controller and shall not rely on external processing or network.
  3. It shall be possible to define a group of objects as a custom event (i.e. meeting, athletic activity, etc.). Events can then be scheduled to operate all necessary equipment automatically.
  4. For points assigned to one common load group, it shall be possible to assign variable time delays between each successive start and/or stop within that group.
  5. The operator shall be able to define the following information:
    - a. Time, day
    - b. Commands such as on, off, auto, etc.
    - c. Time delays between successive commands.
    - d. There shall be provisions for manual overriding of each schedule by an authorized operator.
  6. It shall be possible to schedule calendar-based events up to one year in advance based on the following:
    - a. Weekly Schedule. Provide separate schedules for each day of the week. Each of these schedules should include the capability for start, stop, optimal start, optimal stop, and night economizer. When a group of objects are scheduled together as an Event, provide the capability to adjust the start and stop times for each member.
    - b. Exception Schedules. Provide the ability for the operator to designate any day of the year as an exception schedule. Exception schedules may be defined up to a year in advance. Once an exception schedule is executed, it will be discarded and replaced by the standard schedule for that day of the week.
    - c. Holiday Schedules. Provide the capability for the operator to define up to 99 special or holiday schedules. These schedules may be placed on the scheduling calendar and will be repeated each year. The operator shall be able to define the length of each holiday period.



- F. Automatic Daylight Savings Time Switchover: The system shall provide automatic time adjustment for switching to/from Daylight Savings Time.
- G. Night setback control. The system shall provide the ability to automatically adjust setpoints for night control.
- H. Enthalpy switchover (economizer). The Building Controller Software (BCS) shall control the position of the air handler relief, return, and outside air dampers. If the outside air dry bulb temperature falls below changeover set point the BCS will modulate the dampers to provide 100 percent outside air. The user will be able to quickly changeover to an economizer system based on dry bulb temperature and will be able to override the economizer cycle and return to minimum outside air operation at any time.
- I. PID Control. A PID (proportional-integral-derivative) algorithm with direct or reverse action and anti-windup shall be supplied. The algorithm shall calculate a time-varying analog value that is used to position an output or stage a series of outputs. The controlled variable, set point, and PID gains shall be user-selectable.
- J. Sequencing. Provide application software based upon the sequences of operation specified to properly sequence equipment.
- K. Staggered Start:
  - 1. This application shall prevent all controlled equipment from simultaneously restarting after a power outage. The order in which equipment (or groups of equipment) is started, along with the time delay between starts, shall be user definable.
  - 2. Upon the resumption of power, each Building Controller shall analyze the status of all controlled equipment, compare it with normal occupancy scheduling and turn equipment on or off as necessary to resume normal operations.
- L. Totalization:
  - 1. Run-Time Totalization. Building Controllers shall automatically accumulate and store run-time hours for all digital input and output points. A high runtime alarm shall be assigned, if required, by the operator.
  - 2. Consumption totalization. Building Controllers shall automatically sample, calculate and store consumption totals on a daily, weekly or monthly basis for all analog and digital pulse input type points.
  - 3. Event totalization. Building Controllers shall have the ability to count events such as the number of times a pump or fan system is cycled on and off. Event totalization shall be performed on a daily, weekly or monthly basis for all points. The event totalization feature shall be able to store the records associated with events before reset.
- M. Data Collection:
  - 1. A variety of historical data collection utilities shall be provided to manually or automatically sample, store, and display system data for all points.
  - 2. Building Controllers shall store point history data for selected analog and digital inputs and outputs:

- a. Any point, physical or calculated may be designated for trending. Any point, regardless of physical location in the network, may be collected and stored in each Building Controllers point group.
3. Trend data shall be stored at the Building Controllers and uploaded to the workstation when retrieval is desired. Uploads shall occur based upon either user-defined interval, manual command or when the trend buffers are full. All trend data shall be available for use in 3rd party personal computer applications.
4. Loop Tuning. Building Controllers shall also provide high resolution sampling capability for verification of control loop performance. Operator-initiated automatic and manual loop tuning algorithms shall be provided for a minimum of 36 operator-selected PID control loops. Provide capability to view or print trend and tuning reports.
  - a. In automatic mode, the controller shall perform a step response test with a minimum one-second resolution, evaluate the trend data, calculate the new PID gains and input these values into the selected LOOP statement.
  - b. Loop tuning shall be capable of being initiated either locally at the Building Controller, from a network workstation or remotely using dial-in modems. For all loop tuning functions, access shall be limited to authorized personnel through password protection.

## 2.5 AUXILLARY CONTROL DEVICES

### A. MOTORIZED OR ELECTRICALLY ACTIVATED ISOLATION VALVES

1. Butterfly Valves.
  - a. Furnish automatic butterfly valves for isolation requirements as shown on the drawings or required herein. All butterfly valves shall have body ratings in accordance with the piping specifications. Valves shall be high performance, fully lugged with carbon steel body ANSI 150/300. Valves shall be rated for bubble tight dead end closure, with 316 stainless steel disc, stainless steel shaft and reinforced Teflon seat and seals.
  - b. Motorized valves located outdoors or in areas subject to outdoor air conditions provide fail in place, electric operators with water proof enclosure, crankcase heater, and open and closed position limit switches. Valve and all accessories shall be constructed for outdoor use. All electrical devices shall be weather proof and NEMA 4 rated.
  - c. All valves shall be provided with external position indicators and a speed control device to prevent to rapid closure.
  - d. All valves shall be provided with manual override hand wheels for operating the valve.
  - e. The valves shall be line size as shown on plans.
2. Manufacturer: Bray, or approved equal.

### B. BALL VALVES (ELECTRICALLY ACTIVATED).



1. Furnish automatic full port ball valves for isolation requirements on line sizes up to 2' as shown on the drawings or required herein. All ball valves shall have ANSI 250 body rating. Valves shall have bronze body and stainless steel trim.
2. Valves shall close against a differential pressure equal to the design pump head pressure plus 10%.
3. The valves shall fail to their safe position upon power loss as specified in the sequence of operation.
4. All valves shall be provided with manual override.
5. Provide valve position indicator end switches with the actuator.
6. The valves shall be line size as shown on plans.
7. Manufacturer: Apollo, or approved equal.

C. AUTOMATIC CONTROL VALVES.

1. General:
  - a. Control valves shall be two-way or three-way type single seated globe type for two-position or modulating service as shown. Valves shall meet ANSI Class IV leakage rating.
  - b. Body pressure rating and connection type construction shall conform to pipe, fitting and valve schedules. Where pressure and flow combinations exceed ratings for commercial valves and operators, industrial class valves and operators shall be provided.
  - c. Valve operators shall be of electric type.
  - d. The valves shall be quiet in operation and fail-safe in either normally open or normally closed position, as shown in the drawings, in the event of power failure.
  - e. Control valve operators shall be sized to close against a differential pressure equal to the design pump head plus 10 percent.
  - f. Furnish differential pressure control valves for all water systems as shown on plans and/or specified in the sequence of operations.
  - g. Provide valves 2" and smaller with screwed end bronze bodies and stainless steel trim.
  - h. Provide valves 2-1/2" and larger with flanged ends, cast iron body and stainless steel trim.
  - i. Butterfly or v-port ball valves are allowed for modulating services that require large valve sizes (above 6"), such as cooling tower temperature bypass, chiller head pressure, etc. where proper control with globe type control valve cannot be achieved or the application is not economical.
2. Water Valves:
  - a. Control valves shall be of equal percentage flow characteristics for modulating service.
  - b. Sizing Criteria: As shown on drawings.
3. Steam Valves:
  - a. Control valves shall be of linear flow characteristics for modulating service.
  - b. Sizing Criteria: As shown on drawings.

D. TEMPERATURE SENSORS.

1. Provide the following instrumentation as required by the monitoring, control and optimization functions. All temperature sensor shall use platinum RTD elements only, nickel or silicon are not acceptable. All control signals shall be via a 4-20 mA loop.
2. Liquid Immersion Temperature
  - a. Temperature monitoring range: +20/+120 F or +70/+220 F
  - b. Output signal: 4-20 mA
  - c. Installation adjustment: none required
  - d. Calibration adjustments: zero & span
  - e. Factory calibration point: 70 deg F
  - f. Accuracy at calibration point: +0.5 F
3. Manufacturer: Pyromation; R1T Series; or approved equal.

E. WATER DIFFERENTIAL PRESSURE SENSOR

1. General:
  - a. Transducer shall have linear output signal.
  - b. Zero and span shall be field adjustable.
  - c. Transducer sensing elements shall withstand continuous operating conditions of positive or negative pressure 50% greater than calibrated span without damage.
2. Gage Pressure:
  - a. Water pressure transducer shall have stainless steel diaphragm construction, proof pressure of 150 psi minimum.
  - b. Transducer shall be complete with 4 to 20 mA output, required mounting brackets, and block and bleed valves.
3. Differential:
  - a. Water differential pressure transducer shall have stainless steel diaphragm construction, proof pressure of 150 psi minimum.
  - b. Overrange limit (differential pressure) and maximum static pressure shall be 300 psi.
  - c. Transducer shall be complete with 4 to 20 mA output, required mounting brackets, and three valve manifold.
4. Provide industrial grade differential pressure sensors for all differential pressure bypass valves.
  - a. Sensor shall be factory calibrated for operating range and rated for system pressure.
  - b. Provide manufacturers standard 316 stainless steel, 3 valve manifold and pressure gauges for supply and return pressures. Output shall be 4-20 ma.
5. Manufacturer: Endress + Hausor; see Instrument List, Drawing J0.3; or approved equal.

F. DIFFERENTIAL PRESSURE SWITCHES.

1. Water Differential Pressure Switch
  - a. Differential pressure type switches (air or water service) shall be UL listed, SPDT snap-acting, pilot duty rated (125 VA minimum), NEMA 1 enclosure, with scale range and differential suitable for intended application or as shown.
  - b. The differential switches shall meet the following requirements:

1)	Range	8 to 70 psi
2)	Differential	3 psi
3)	Maximum differential pressure	200 psi
4)	Maximum pressure	325 psi

G. ANALOG WATER LEVEL SENSORS

1. Furnish and install full height, analog level sensors for each location as specified. Sensor shall provide 4-20ma signal in proportion to basin water level. Provide waterproof enclosure and mounting hardware as required.

H. WATER BTU METERS

1. Manufacturer: Onicon, System 10 P-1; or approved equal.
2. Provide insertion type water flow meters designed to mount through a fully open 1 inch full bore ball valve supplied by flow meter manufacturer. Meter flow range shall be 2-40 feet/second for liquid service. Meter linearity shall be +/-1% for a 10:1 range. Repeatability shall be .10%. All wetted parts shall be constructed of stainless steel, bearings shall be tungsten carbide. Housing and flange shall be carbon steel. Housing pressure rating shall be 350 psig. A D.C. powered transmitter shall be mounted on the flow meter. Flow transmitter output shall be 4-20 mA linear with flow. Transmitter input shall be from magnetic pickup. Transmitter accuracy shall be .25% of span. The water flow meter shall be Onicon F 1220 or equal.
3. Provide supply and return temperature sensors for "Delta-T" calculation of BTU consumption. Monitor total accumulated BTUs, current BTUs, monthly total BTUs, and yearly total BTUs for each location specified or shown.
4. Provide isolation valve kit to allow removal and servicing of meter while system is operating.
5. All devices associated with the BTU meters serving the chilled water and ice storage system shall be suitable for the extreme environmental conditions. The devices shall properly operate with the specified accuracy and shall not be affected by the media, or by the environment that includes but not limited to low temperatures (10 Deg F), temperature fluctuations and condensation. Control panel enclosures and electronics shall meet the aforementioned requirements or located strategically to ensure proper operation.

I. FLOW SENSING

1. Vortex Shedding Flow Meters: Condensate System
  - a. Provide ~~insertion~~ vortex shedding flow meter for condensate metering locations. Meter shall be temperature compensated, rated for service conditions.
  - b. Manufactured by Endress + Hauser (E + H); or approved equal. Provide remote readout of pressure, flow, MLb/Hr and total MLb.
  - c. Coordinate location to provide proper straight run of pipe, pipe size, etc.
  - d. Power 24VDC power supply as required from Emergency source.
  - e. BMS system shall monitor Mlb/Hr, Mlb total, and temperature values.
2. Turbine Flow – Single Direction (For Chilled Water System)
  - a. Manufacturer: Onicon; Model F-1200, or approved equal.
  - b. Turbine flow with electronic sensing
  - c. Suitable for 2 ½ inch through 24 inch pipe size

- d. 24V-DC supply voltage
  - e. Suitable for 180F-200F temperature maximum
  - f. Ambient temperature range: -5 to 160F
  - g. Operating Pressure: 400psi (Maximum)
  - h. Output: 0-15V peak pulse
  - i. Wetted Material: 316 stainless steel
  - j. Electronics Enclosure: Weatherlite aluminum
  - k. Electrical Connection: 3-wire (minimum), Length: 10 ft. cable
3. Turbine Flow – Bi-Directional Direction (For Chilled Water System)
- a. Manufacturer: Onicon; Mode FB-1200; or approved equal.
  - b. Similar to F-1200 above, except with directional contact output.

J. INDOOR AIR QUALITY SENSORS

1. Refrigeration: Infrared sensing, microprocessor controlled digital transmitting Carbon Dioxide gas monitor suitable for refrigeration gas. Type R134a; duct or wall mounting.
- a. Detection Range: 0-2000 PPM, \*0-2% OR \*0-5%
  - b. Accuracy:  $\pm 3\%$
  - c. Response Time: 35 sec. (for 90% of the reading)
  - d. Sensor Life Expectancy: > 10 years
  - e. Outputs: 4-20 mA, 0-5 Vdc or 0-10 Vdc
  - f. Relay Output Rating: 5A, 30 Vdc or 250 Vac resistive load)
  - g. Power Requirement: 17-27 Vac or 24-38 Vdc, 200 mA
  - h. Operating Temperature Range: 32°F to 100°F (0°C to 40°C)
  - i. Operating Humidity Range: 0% - 95% RH, Non-Condensing
2. Manufacturer: MSA; Model Chillguard LE; or approved equal.

K. RELAYS.

1. Control relays shall be UL listed plug-in type with dust cover and LED “energized” indicator. Contact rating, configuration, and coil voltage shall be suitable for application.
2. Time delay relays shall be UL listed solid-state plug-in type with adjustable time delay. Delay shall be adjustable  $\pm 200\%$  (minimum) from set point shown on plans. Contact rating, configuration, and coil voltage shall be suitable for application. Provide NEMA 1 enclosure when not installed in local control panel.

L. LOCAL CONTROL PANELS.

1. All indoor control cabinets shall be fully enclosed NEMA 1 construction with (hinged door) key-lock latch and removable sub panels. A single key shall be common to all field panels and sub panels.
2. Interconnections between internal and face mounted devices shall be prewired with color-coded stranded conductors neatly installed in plastic troughs and/or tie-wrapped. Terminals for field connections shall be UL listed for 600 volt service, individually identified per control/ interlock drawings, with adequate clearance for field wiring. Control terminations for field connection shall be individually identified per control drawings.
3. Provide ON/OFF power switch with overcurrent protection for control power sources to each local panel.

M. LEVEL SWITCHES.

1. Condensate Tank: Magnetic level gage, including site glass indicator tube, float chamber with flood assembly, upper and lower switches.
  - a. Materials shall be stainless steel with gage indicator.
  - b. Float Chamber: 2 ½ inch stainless steel pipe. Scale on indicator shall have ½ inch scale dimensions.
  - c. Switches shall be reed switches.
  - d. Connection to tank by 1 inch MNPT, top and bottom, vertical distance between upper and lower points is 48 inches.
  - e. Contractor shall field verify distance between points of connection.
  - f. Manufacturer: Babbitt International, Model: LGG series; or approved equal.
  
2. Sump: Tethered float switch
  - a. Single-pole-double-throw switch.
  - b. PVC float.
  - c. PVC sheathed cable.
  - d. Manufacturer: Magnetrol; Model T10; or approved equal.

## 2.6 COMMUNICATION AND CONTROL WIRING

- A. General:
  1. Provide copper wiring, plenum cable, and raceways as specified in the applicable sections of Division 16 unless otherwise noted herein.
  2. All insulated wire to be copper conductors, UL labeled for 90°C minimum service.
  
- B. Wire Sizing and Insulation
  1. Wiring shall comply with minimum wire size and insulation based on services listed below:

Service	Minimum Gage/Type	Insulation Class
AC 24V Power	12 Ga Solid	600 Volt
DC 24V Power	10 Ga Solid	600 Volt
Class 1	14 Ga Stranded	600 Volt
Class 2	18 Ga Stranded	300 Volt
Class 3	18 Ga Stranded	300 Volt
  2. Provide plenum-rated cable when open cable is permitted in supply or return air plenum where allowed per execution specifications defined in Paragraph 3.07
  
- C. Power Wiring:
  1. 115V power circuit wiring above 100 feet distance shall use minimum 10 gage.
  2. 24V control power wiring above 200 feet distance shall use minimum 12 gage.
  
- D. Control Wiring:
  1. Digital Input/Output wiring shall use Class 2 twisted pair, insulated.
  2. Analog inputs shall use Class 2 twisted shielded pair, insulated and jacketed and require a grounded shield.
  3. Actuators with tri-state control shall use 3 conductor with same characteristics

- E. Communication Wiring
  - 1. Ethernet Cable shall be minimum CAT5
  - 2. Secondary level network shall be 24 gage, TSP, low capacitance cable
- F. Approved Cable Manufacturers:
  - 1. Wiring from the following manufacturers which meet the above criteria shall be acceptable:
    - a. Anixter
    - b. Belden

### PART 3 EXECUTION

#### 3.1 EXAMINATION

- A. The project plans shall be thoroughly examined for control device and equipment locations. Any discrepancies, conflicts, or omissions shall be reported to the architect/engineer for resolution before rough-in work is started.
- B. The contractor shall inspect the site to verify that equipment may be installed as shown. Any discrepancies, conflicts, or omissions shall be reported to the engineer for resolution before rough-in work is started.

#### 3.2 COORDINATION

- A. Site
  - 1. The project coordination between trades is the responsibility of the prime contractor who is the one tier higher contractual partner such as mechanical contractor, general contractor, construction manager, owner or owner's representative as applicable.
  - 2. The controls contractor shall follow prime contractor's job schedule and coordinate all project related activities through the prime contractor except otherwise agreed or in minor job site issues. Reasonable judgment shall be applied.
  - 3. Where the work will be installed in close proximity to, or will interfere with, work of other trades, the contractor shall assist in working out space conditions to make a satisfactory adjustment.
  - 4. If the contractor deviates from the job schedule and installs work without coordinating with other trades, so as to cause interference with work of other trades, the contractor shall make the necessary changes to correct the condition without extra charge.
  - 5. Coordinate and schedule work with all other work in the same area, or with work that is dependent upon other work, to facilitate mutual progress.
- B. Submittals.
  - 1. Refer to the "Submittals" article in Part 1 of this specification for requirements.
- C. Test and Balance
  - 1. The contractor shall furnish a single set of all tools necessary to interface to the control system for test and balance purposes.

- D. Coordination with controls specified in other sections or divisions.
  - 1. Other sections and/or divisions of this specification include controls and control devices that are to be part of or interfaced to the control system specified in this section. These controls shall be integrated into the system and coordinated by the contractor as follows:
    - a. All communication media and equipment shall be provided as specified in Part 2, “Communication” of this specification.
    - b. Each supplier of controls product is responsible for the configuration, programming, startup, and testing of that product to meet the sequences of operation described in this section.
    - c. The Contractor shall coordinate and resolve any incompatibility issues that arise between the control products provided under this section and those provided under other sections or divisions of this specification.

### 3.3 GENERAL WORKMANSHIP

- A. Install equipment, piping, and wiring/raceway parallel to building lines (i.e., horizontal, vertical, and parallel to walls) wherever possible.
- B. Verify integrity of all wiring to ensure continuity and freedom from shorts and grounds.
- C. All equipment, installation, and wiring shall comply with acceptable industry specifications and standards for performance, reliability, and compatibility and be executed in strict adherence to local codes and standard practices.

### 3.4 EXISTING EQUIPMENT

- A. Unless otherwise directed, the contractor is not responsible for the repairs or replacement of existing energy equipment and systems, valves, dampers, or actuators. Should the contractor find existing equipment that requires maintenance, the engineer is to be notified immediately.
- B. Electronic Sensors and Transmitters: Unless specifically noted otherwise, remove and deliver to the Owner.
- C. Controllers and Auxiliary Electronic Devices: Salvage, recondition, and reuse.
- D. Pneumatic Controllers, Relays and Gauges: Deliver to owner.
- E. Damper Actuators, Linkages, and Appurtenances: Salvage, recondition, and reuse.
- F. Control Valves: Salvage, recondition, and reuse.
- G. Control Compressed Air System: Salvage, recondition, and reuse.

### 3.5 WIRING

- A. All control and interlock wiring shall comply with national and local electrical codes and Division 16 of this specification. Where the requirements of this section differ from those in Division 16, the requirements of this section shall take precedence.



- B. All NEC Class 1 (line voltage) wiring shall be UL Listed in approved conduit according to NEC and Division 16 requirements.
- C. All low-voltage wiring shall meet NEC Class 2 requirements. (Low-voltage power circuits shall be sub fused when required to meet Class 2 current limit.)
- D. Where NEC Class 2 (current-limited) wires are in concealed and accessible locations, including ceiling return air plenums, approved cables not in conduit may be used provided that cables are UL Listed for the intended application. For example, cables used in ceiling plenums shall be UL Listed specifically for that purpose.
- E. All wiring in mechanical, electrical, or service rooms—or where subject to mechanical damage— shall be installed in conduit.
- F. Do not install Class 2 wiring in conduit containing Class 1 wiring. Boxes and panels containing high voltage wiring and equipment may not be used for low-voltage wiring except for the purpose of interfacing the two (e.g., relays and transformers).
- G. Do not install wiring in conduit containing tubing.
- H. All wire-to-device connections shall be made at a terminal block or wire nut. All wire-to-wire connections shall be at a terminal strip or wire nut.
- I. All wiring within enclosures shall be neatly bundled and anchored to permit access and prevent restriction to devices and terminals.
- J. Maximum allowable voltage for control wiring shall be 120 V. If only higher voltages are available, the contractor shall provide step-down transformers or interposing relays.
- K. All plenum rated wiring shall be installed as continuous lengths, with no splices permitted between termination points
- L. All wiring in conduit shall be installed as continuous lengths, with no splices permitted between termination points or junction boxes.
- M. Maintain fire rating at all penetrations. Install plenum wiring in sleeves where it passes through walls and floors.
- N. Size and type of conduit and size and type of wire shall be the responsibility of the contractor, in keeping with the manufacturer's recommendations and NEC requirements, except as noted elsewhere.
- O. Include one pull string in each conduit 3/4 in. or larger.
- P. Control and status relays are to be located in designated enclosures only. These enclosures can include packaged equipment control panel enclosures unless they also contain Class 1 starters.



- Q. Conceal all conduit, except within mechanical, electrical, or service rooms. Install conduit to maintain a minimum clearance of 15 cm (6 in.) from high-temperature equipment (e.g., steam pipes or flues).
- R. Secure conduit with conduit clamps fastened to the structure and spaced according to code requirements. Conduit and pull boxes may not be hung on flexible duct strap or tie rods. Conduits may not be run on or attached to ductwork.
- S. Adhere to this specification's Division 16 requirements where conduit crosses building expansion joints.
- T. The Contractor shall terminate all control and/or interlock wiring and shall maintain updated (as-built) wiring diagrams with terminations identified at the job site.
- U. Flexible metal conduits and liquid-tight, flexible metal conduits shall not exceed 1 m (3 ft) in length and shall be supported at each end. Flexible metal conduit less than ½ in. electrical trade size shall not be used. In areas exposed to moisture, including chiller and boiler rooms, liquid-tight, flexible metal conduits shall be used.
- V. Conduit must be adequately supported, properly reamed at both ends, and left clean and free of obstructions. Conduit sections shall be joined with couplings (according to code). Terminations must be made with fittings at boxes, and ends not terminating in boxes shall have bushings installed.

### 3.6 COMMUNICATION WIRING

- A. The contractor shall adhere to the items listed in the "Wiring" article in Part 3 of the specification.
- B. All cabling shall be installed in a neat and workmanlike manner. Follow manufacturer's installation recommendations for all communication cabling.
- C. Do not install communication wiring in raceway and enclosures containing Class 1 or other Class 2 wiring.
- D. Maximum pulling, tension, and bend radius for cable installation, as specified by the cable manufacturer, shall not be exceeded during installation.
- E. Contractor shall verify the integrity of the entire network following the cable installation. Use appropriate test measures for each particular cable.
- F. When a cable enters or exits a building, a lightning arrestor must be installed between the lines and ground. The lightning arrestor shall be installed according to the manufacturer's instructions.
- G. All runs of communication wiring shall be unspliced length when that length is commercially available.
- H. All communication wiring shall be labeled to indicate origination and destination data.

- I. Grounding of coaxial cable shall be in accordance with NEC regulations article on “Communications Circuits, Cable, and Protector Grounding.”

### 3.7 INSTALLATION OF SENSORS

- A. General:
  1. Install sensors in accordance with the manufacturer’s recommendations.
  2. Mount sensors rigidly and adequately for the environment within which the sensor operates.
  3. All wires attached to sensors shall be air sealed in their raceways or in the wall to stop air transmitted from other areas affecting sensor readings.
- B. Instrumentation Installed in Piping Systems
  1. Thermometers and temperature sensing elements installed in liquid systems shall be installed in thermowells.
  2. All pipe-mounted temperature sensors shall be installed in wells.
- C. Water Differential pressure sensors
  1. Differential pressure sensors shall be installed with valved taps into the piping to ensure serviceability without draining the system
  2. Sensors shall be mounted with bleed valves. After sensor installation any air shall be eliminated using the bleed valves to ensure reading accuracy
  3. The sensors shall be located to ensure accessibility
  4. Flow meters
  5. The minimum straight unobstructed piping for the flowmeter installation shall be at least 10 pipe diameters upstream and at least 5 pipe diameters downstream and/or in accordance with the manufacturer's installation instructions.

### 3.8 WARNING LABELS AND IDENTIFICATION TAGS

- A. Permanent warning labels shall be affixed to all equipment that can be automatically started by the DDC system.
  1. Labels shall use white lettering (12-point type or larger) on a red background.
  2. Warning labels shall read as follows: “C A U T I O N This equipment is operating under automatic control and may start or stop at any time without warning. Switch disconnect to “Off” position before servicing.”
- B. Permanent warning labels shall be affixed to all motor starters and all control panels that are connected to multiple power sources utilizing separate disconnects.
  1. Labels shall use white lettering (12-point type or larger) on a red background.
  2. Warning labels shall read as follows: “C A U T I O N This equipment is fed from more than one power source with separate disconnects. Disconnect all power sources before servicing.”
- C. Equipment and Device labeling:
  1. Labels and tags shall be keyed to the unique identifiers shown on the As-Built drawings.
  2. All Enclosures and DDC Hardware shall be labeled.
  3. All sensors and actuators not in occupied areas shall be tagged.

4. Airflow measurement arrays shall be tagged to show flow rate range for signal output range, duct size, and pitot tube AFMS flow coefficient.
  5. Duct static pressure taps shall be tagged at the location of the pressure tap.
  6. Tags shall be plastic or metal and shall be mechanically attached directly to each device or attached by a metal chain or wire.
  7. Labels exterior to protective enclosures shall be engraved plastic and mechanically attached to the enclosure or DDC Hardware.
  8. Labels inside protective enclosures may be attached using adhesive, but shall not be hand written.
  9. Identify all other control components with permanent labels. All plug-in components shall be labeled such that removal of the component does not remove the label.
  10. Identify room sensors relating to terminal box or valves with nameplates.
  11. Manufacturers' nameplates and UL or CSA labels are to be visible and legible after equipment is installed.
- D. Identification of Tubing and Wiring
1. All wiring and cabling including that within factory-fabricated panels shall be labeled at each end within 5 cm (2 in.) of termination with the DDC address or termination number.
  2. Permanently label or code each point of field terminal strips to show the instrument or item served.
  3. All pneumatic tubing shall be labeled at each end within 5 cm (2 in.) of termination with a descriptive identifier.

### 3.9 IDENTIFICATION OF HARDWARE AND WIRING

- A. See Section 26 05 53 – Identification for Structural System
- B. All wiring and cabling, including that within factory-fabricated panels shall be labeled at each end within 5 cm (2 in.) of termination with the DDC address or termination number.
- C. All pneumatic tubing shall be labeled at each end within 5 cm (2 in.) of termination with a descriptive identifier.
- D. Permanently label or code each point of field terminal strips to show the instrument or item served.
- E. Identify control panels with laminated plastic nameplates, as per Section 26 05 53.
- F. Identify all other control components with permanent labels. All plug-in components shall be labeled such that removal of the component does not remove the label.
- G. Manufacturers' nameplates and UL or CSA labels are to be visible and legible after equipment is installed.
- H. Identifiers shall match record documents.

### 3.10 CONTROL SYSTEM CHECKOUT AND TESTING

- A. Perform a three-phase commissioning procedure consisting of field I/O calibration and commissioning, system commissioning and integrated system program commissioning. Document all commissioning information on commissioning data sheets that shall be submitted prior to acceptance testing. Commissioning work that requires shutdown of system or deviation from normal function shall be performed when the operation of the system is not required. The commissioning must be coordinated with the owner and construction manager to ensure systems are available when needed. Notify the operating personal in writing of the testing schedule so that authorized personnel from the owner and construction manager are present throughout the commissioning procedure.
  
- B. Phase I – Field I/O Calibration and Commissioning
  - 1. Verify that each control panel has been installed according to plans, specifications and approved shop drawings. Calibrate, test, and have signed off each control sensor and device. Commissioning to include, but not be limited to:
    - a. Sensor accuracy at 10, 50 and 90% of range.
    - b. Sensor range.
    - c. Verify analog limit and binary alarm reporting.
    - d. Point value reporting.
    - e. Binary alarm and switch settings.
    - f. Actuator and positioner spring ranges if pneumatic actuation is utilized.
    - g. Fail safe operation on loss of control signal, pneumatic air, electric power, network communications, etc.
  
- C. Phase II – System Commissioning
  - 1. Each BMS program shall be put on line and commissioned. The contractor shall, in the presence of the owner and construction manager, demonstrate each programmed sequence of operation and compare the results in writing.
  - 2. In addition, each control loop shall be tested to verify proper response and stable control, within specified accuracy.
  - 3. System program test results shall be recorded on commissioning data sheets and submitted for record. Any discrepancies between the specification and the actual performance will be rectified and re-tested.
  
- D. Phase III - Integrated System Program Commissioning
  - 1. Tests shall include, but not be limited to:
    - a. Data communication, both normal and failure modes.
    - b. Fully loaded system response time.
    - c. Impact of component failures on system performance and system operation.
    - d. Time/Date changes.
    - e. End of month/ end of year operation.
    - f. Season changeover.
    - g. Global application programs and point sharing.
    - h. System backup and reloading.
    - i. System status displays.
    - j. Diagnostic functions.
    - k. Power failure routines.

1. Battery backup.
  - m. Testing of all electrical and HVAC systems with other division of work.
2. Submit for approval, a detailed acceptance test procedure designed to demonstrate compliance with contractual requirements. This Acceptance test procedure will take place after the commissioning procedure but before final acceptance, to verify that sensors and control devices maintain specified accuracy and the system performance does not degrade over time.
  3. Using the commissioning test data sheets, the contractor shall demonstrate each point. The contractor shall also demonstrate 100 percent of the system functions. The contractor shall demonstrate all points and system functions until all devices and functions meet specification.

### 3.11 CONTROL SYSTEM DEMONSTRATION AND ACCEPTANCE

#### A. Demonstration

1. Prior to acceptance, the control system shall undergo a series of performance tests to verify operation and compliance with this specification. These tests shall occur after the Contractor has completed the installation, started up the system, and performed his/her own tests.
2. The tests described in this section are to be performed in addition to the tests that the contractor performs as a necessary part of the installation, start-up, and debugging process.
3. The demonstration process shall follow that approved in Part 1, "Submittals." The approved checklists and forms shall be completed for all systems as part of the demonstration.
4. As each control input and output is checked, a log shall be completed showing the date, technician's initials, and any corrective action taken or needed.
5. Demonstrate compliance with sequences of operation through all modes of operation.
6. Any tests that fail to demonstrate the operation of the system shall be repeated at a later date. The contractor shall be responsible for any necessary repairs or revisions to the hardware or software to successfully complete all tests.

#### B. Acceptance

1. All tests described in this specification shall have been performed to the satisfaction of both the engineer and owner prior to the acceptance of the control system as meeting the requirements of completion.
2. Any tests that cannot be performed due to circumstances beyond the control of the contractor may be exempt from the completion requirements if stated as such in writing by the engineer. Such tests shall then be performed as part of the warranty.
3. The system shall not be accepted until all forms and checklists completed as part of the demonstration are submitted and approved as required in Part 1, "Submittals."

### 3.12 TRAINING

- A. Provide a minimum of four (4) on-site, on-line, or classroom training sessions throughout the contract period for personnel designated by the owner. Each session shall be a minimum of four (4) hours each
  
- B. Provide 40 hours of site specific training for Owner's operating personnel. Training shall include:
  - 1. Day-to-day Operators:
    - a. Proficiently operate the system
    - b. Understand control system architecture and configuration
    - c. Understand DDC system components
    - d. Operate the workstation and peripherals
    - e. Log on and off the system
    - f. Access graphics, point reports, and logs
    - g. Adjust and change system set points, time schedules, and holiday schedules
    - h. Recognize malfunctions of the system by observation of the graphical visual signals
    - i. Understand system drawings and Operation and Maintenance manual
    - j. Understand the job layout and location of control components
    - k. Access data from DDC controllers
  
  - 2. Advanced Operators:
    - a. Make and change graphics on the workstation
    - b. Create, delete, and modify alarms, including annunciation and routing of these
    - c. Create, delete, and modify point trend logs and graph or print these both on an ad-hoc basis and at user-definable time intervals
    - d. Create, delete, and modify reports
    - e. Add, remove, and modify system's physical points
    - f. Create, modify, and delete programming
    - g. Add panels when required
    - h. Add operator interface stations
    - i. Create, delete, and modify system displays, both graphical and others
    - j. Perform DDC system field checkout procedures
    - k. Perform DDC controller unit operation and maintenance procedures
    - l. Perform workstation and peripheral operation and maintenance procedures
    - m. Perform DDC system diagnostic procedures
    - n. Configure hardware including PC boards, switches, communication, and I/O points
    - o. Maintain, calibrate, troubleshoot, diagnose, and repair hardware
    - p. Adjust, calibrate, and replace system components
  
  - 3. System Managers/Administrators:
    - a. Maintain software and prepare backups
    - b. Interface with job-specific, third-party operator software
    - c. Add new users and understand password security procedures

- C. Since the Owner may require personnel to have more comprehensive understanding of the hardware and software, additional training must be available from the Contractor. If such training is required by the Owner, it will be contracted at a later date. Provide description of available local and factory customer training if requested by owner.

END OF SECTION

INSTALLATION NOTES:

- 1 SEE VFD WIRING DETAIL ON DRAWING 1A
- 2 NEW DEVICE
- 3 EXISTING DEVICE

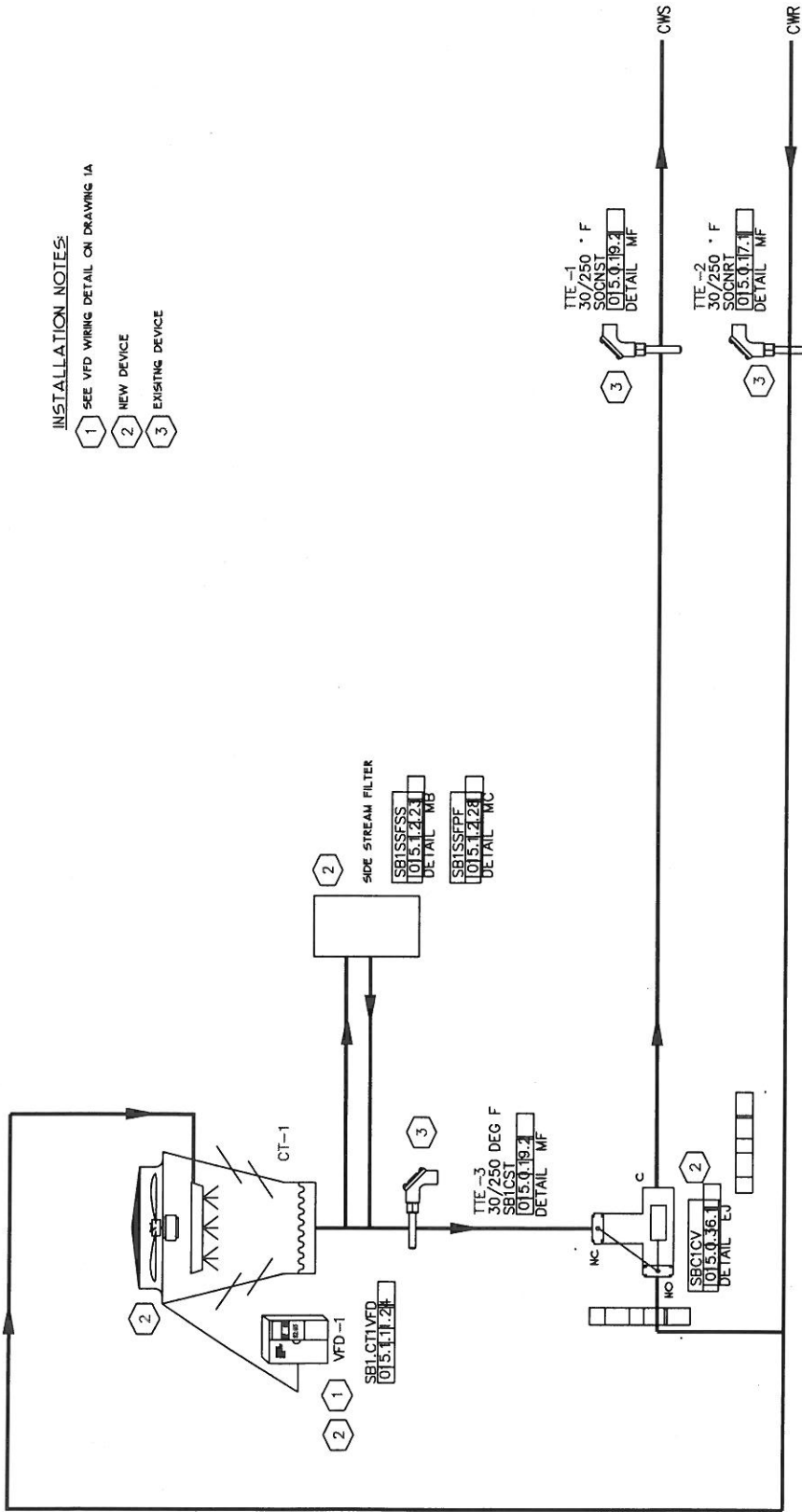

**REVISION HISTORY**

SIEMENS

PSU - SB1 COOLING TOWER  
PORTLAND, OR

REVISION	DATE	BY	DESCRIPTION
1	01/26/2012		

631-PC-1324-01



INSTALLATION NOTES:  
1. ALL WIRING TO MEET REQUIREMENTS OF STANDARD WIRING SPECIFICATIONS DRAWINGS.

631-PC-1324-01  
0  
1A

PSU SB1 COOLING TOWER  
PORTLAND, OR  
DRAWN BY: [ ] CHECKED BY: [ ] DATE: 01/26/2012  
CT-1

SIEMENS

REVISION HISTORY

© COPYRIGHT

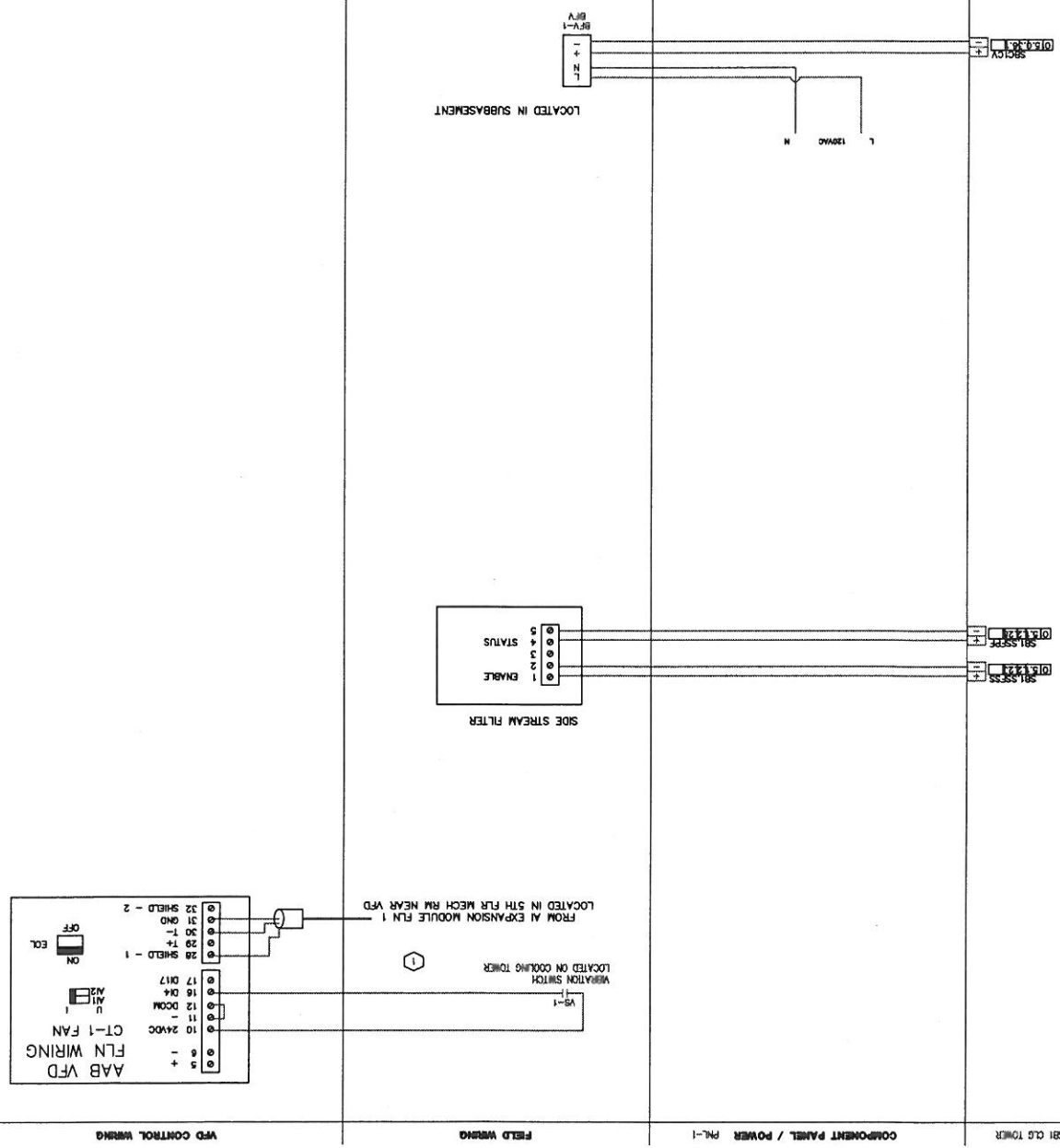

SECTION 23 21 13

HYDRONIC PIPING

PART 1 GENERAL

1.1 SUMMARY

- A. Section Includes:
  - 1. Chilled water piping.
  - 2. Equipment drains and over flows.
  - 3. Unions and flanges.
  - 4. Pipe hangers and supports.
  - 5. Valves.
  
- B. Related Sections:
  - 1. Section 23 05 23 - General-Duty Valves for HVAC Piping.
  - 2. Section 23 05 29 - Hangers and Supports for HVAC Piping and Equipment.
  - 3. Section 23 05 53 - Identification for HVAC Piping and Equipment.
  - 4. Section 23 05 93 – Testing, Adjusting and Balancing
  - 5. Section 23 07 00 - HVAC Insulation.
  - 6. Section 23 21 16 - Hydronic Piping Specialties.

1.2 REFERENCES

- A. American Society of Mechanical Engineers:
  - 1. ASME B16.3 - Malleable Iron Threaded Fittings.
  - 2. ASME B16.4 - Gray Iron Threaded Fittings.
  - 3. ASME B31.1 - Power Piping.
  - 4. ASME B31.9 - Building Services Piping.
  - 5. ASME Section IX - Boiler and Pressure Vessel Code - Welding and Brazing Qualifications.
  
- B. ASTM International:
  - 1. ASTM A53/A53M - Standard Specification for Pipe, Steel, Black and Hot-Dipped, Zinc-Coated, Welded and Seamless.
  - 2. ASTM A234/A234M - Standard Specification for Piping Fittings of Wrought Carbon Steel and Alloy Steel for Moderate and High Temperature Service.
  - 3. ASTM A395/A395M - Standard Specification for Ferritic Ductile Iron Pressure-Retaining Castings for Use at Elevated Temperatures.
  - 4. ASTM A536 - Standard Specification for Ductile Iron Castings.
  - 5. ASTM F708 - Standard Practice for Design and Installation of Rigid Pipe Hangers.
  - 6. ASTM F1476 - Standard Specification for Performance of Gasketed Mechanical Couplings for Use in Piping Applications.
  
- C. American Welding Society:
  - 1. AWS D1.1 - Structural Welding Code - Steel.

- D. American Water Works Association:
  - 1. AWWA C110 - American National Standard for Ductile-Iron and Grey-Iron Fittings, 3 in. through 48 in. (75 mm through 1200 mm), for Water and Other Liquids.
  - 2. AWWA C111 - American National Standard for Rubber-Gasket Joints for Ductile-Iron Pressure Pipe and Fittings.
  - 3. AWWA C151 - American National Standard for Ductile-Iron Pipe, Centrifugally Cast, for Water.
  
- E. Manufacturers Standardization Society of the Valve and Fittings Industry:
  - 1. MSS SP 58 - Pipe Hangers and Supports - Materials, Design and Manufacturer.
  - 2. MSS SP 67 - Butterfly Valves.
  - 3. MSS SP 69 - Pipe Hangers and Supports - Selection and Application.
  - 4. MSS SP 89 - Pipe Hangers and Supports - Fabrication and Installation Practices.
  - 5. MSS SP 110 - Ball Valves Threaded, Socket-Welding, Solder Joint, Grooved and Flared Ends.

### 1.3 SYSTEM DESCRIPTION

- A. Where more than one piping system material is specified, provide compatible system components and joints. Use non-conducting dielectric connections whenever jointing dissimilar metals in open systems.
  
- B. Provide flanges, union, and couplings at locations requiring servicing. Use unions, flanges, and couplings downstream of valves and at equipment or apparatus connections. Do not use direct welded or threaded connections to valves, equipment or other apparatus.
  
- C. Provide pipe hangers and supports in accordance with Section 23 05 29.
  
- D. Provide valves in accordance with Section 23 05 23.
  
- E. Use only butterfly valves in chilled and condenser water systems for throttling and isolation service.
  
- F. Use lug end butterfly valves to isolate equipment.
  
- G. Use 3/4 inch gate or ball valves with cap for drains at main shut-off valves, low points of piping, bases of vertical risers, and at equipment. Pipe to nearest floor drain.
  
- H. Include all incidental items and work not specifically shown or specified but required by good practice in a complete system.
  
- I. The drawings and specifications are complementary. What is called for in one shall be called for in both.
  
- J. Paint piping systems as noted on drawings.

- K. Provide pipe lining systems as indicated on the drawings as an Additive Bid Item (ABI).

#### 1.4 SUBMITTALS

- A. Section 01300 - Submittals: Submittal procedures.
- B. Product Data: (Mark-up selections)
  - 1. Piping: Submit data on pipe materials, fittings, and accessories. Submit manufacturers catalog information.
  - 2. Valves: Submit manufacturers catalog information with valve data and ratings for each service.
  - 3. Hangers and Supports: Submit manufacturers catalog information including load capacity.
- C. Design Data: Indicate pipe size. Indicate load carrying capacity of trapeze, multiple pipe, and riser support hangers. See specification section 23 05 29.
- D. Test Reports: Indicate results of piping system pressure test.
- E. Manufacturer's Installation Instructions: Submit hanging and support methods, joining procedures and isolation.
- F. Manufacturer's Certificate: Certify products meet or exceed specified requirements.
- G. Welders' Certificate: Include welders' certification of compliance with ASME Section IX.
- H. Shop Drawings:
  - 1. Piping System: Indicate layout of each piping system to scale. Indicate piping system touring showing piping sizes, elevations, pipe length, fitting locations, valve locations, expansion joints, anchor locations, etc.

#### 1.5 CLOSEOUT SUBMITTALS

- A. Section 01780 – Contract Closeout: Requirements for Submittals.
- B. Project Record Documents: Record actual locations of valves, equipment and accessories.
- C. Operation and Maintenance Data: Submit instructions for installation and changing components, spare parts lists, exploded assembly views.

#### 1.6 QUALITY ASSURANCE

- A. Perform Work in accordance with ASME B31.1 or ASME B31.9 code for installation of piping systems and ASME Section IX for welding materials and procedures.
- B. Perform Work in accordance with applicable authority for welding hanger and support attachments to building structure.
- C. Maintain one copy of each document on site.

## 1.7 QUALIFICATIONS

- A. Manufacturer: Company specializing in manufacturing products specified in this section with minimum three years documented experience.
- B. Fabricator or Installer: Company specializing in performing Work of this section with minimum three years documented experience and/or approved by manufacturer.

## 1.8 PRE-INSTALLATION MEETINGS

- A. Section 01040 – Project Coordination: Construction Coordination
- B. Convene minimum one week prior to commencing work of this section.

## 1.9 DELIVERY, STORAGE, AND HANDLING

- A. Section 01630 - Product Requirements: Product storage and handling requirements.
- B. Accept valves on site in shipping containers with labeling in place. Inspect for damage.
- C. Provide temporary end caps and closures on piping and fittings. Maintain in place until installation.
- D. Protect piping systems from entry of foreign materials by temporary covers, completing sections of the Work, and isolating parts of completed system.

## 1.10 ENVIRONMENTAL REQUIREMENTS

- A. Not Used

## 1.11 FIELD MEASUREMENTS

- A. Verify field measurements prior to fabrication.

## 1.12 COORDINATION

- A. Section 01040 – Project Coordination: Construction Coordination.

## 1.13 WARRANTY

- A. Section 01780 – Contract Closeout: Warranties and Bonds.
- B. Furnish five year manufacturer warranty for valves excluding packing.

## 1.14 EXTRA MATERIALS

- A. Section 01780 – Contract Closeout: Spare parts and extra quantities.
- B. Furnish two packing kits for each size and valve type.

## PART 2 PRODUCTS

### 2.1 CHILLED WATER PIPING, ABOVE GROUND

- A. See piping schedule on drawings

### 2.2 CONDENSATE WATER PIPING

- A. See piping schedule on drawings.

### 2.3 EQUIPMENT DRAINS AND OVERFLOWS

- A. Not used.

### 2.4 UNIONS AND FLANGES

- A. Unions for Pipe 2 inches and Smaller:
  - 1. Ferrous Piping: Class 150, malleable iron, threaded.
  - 2. Dielectric Connections: Union with galvanized or plated steel threaded end, copper solder end, water impervious isolation barrier.
- B. Flanges for Pipe 2-1/2 inches and Larger:
  - 1. Ferrous Piping: Class 150, forged steel, slip-on flanges.
  - 2. Gaskets: 1/16 inch thick preformed neoprene gaskets.

### 2.5 VALVES

- A. See Section 23 05 23, “General Duty Valves and Accessories”

### 2.6 PIPE HANGERS AND SUPPORTS

- A. See Section 23 05 29, “Hangers & Pipe Supports for Piping and Equipment”

### 2.7 PAINT ON PIPING SYSTEM

- A. Provide industrial grade exterior coating on piping as noted on drawings – provide submittal with bid.

### 2.8 PIPE LINING SYSTEM (ABI-1)

- A. Liquid Epoxy System conforming to ANSI C210.
- B. Acceptable Manufacturers:
  - 1. Nuflow America
  - 2. American Pipe Lining Inc.

### PART 3 EXECUTION

#### 3.1 EXAMINATION

- A. Section 01040 – Project Coordination: Coordination and project conditions.
- B. Verify excavations are to required grade, dry, and not over-excavated.

#### 3.2 PREPARATION

- A. Ream pipe and tube ends. Remove burrs. Bevel plain end ferrous pipe.
- B. Remove scale and dirt on inside and outside before assembly.
- C. Prepare piping connections to equipment with flanges or unions.
- D. Keep open ends of pipe free from scale and dirt. Protect open ends with temporary plugs or caps.
- E. After completion, fill, clean, and treat systems.
- F. Chilled Water Systems
  1. Circulate for 48 hours, then drain systems as quickly as possible.
  2. Refill with clean water, circulate for 24 hours, then drain.
  3. Refill with clean water and repeat until system cleaner is removed.
- G. Use neutralizer agents on recommendation of system cleaner supplier and acceptance of Architect/Engineer.
- H. Flush open systems with clean water for one hour minimum. Drain completely and refill.
- I. Remove, clean, and replace strainer screens.
- J. Inspect, remove sludge, and flush low points with clean water after cleaning process is completed. Include disassembly of components as required.

#### 3.3 INSTALLATION - PIPE HANGERS AND SUPPORTS

- A. Install pipe hangers and supports in accordance with Section 23 05 29.

#### 3.4 INSTALLATION - PIPING SYSTEMS

- A. Install piping in accordance with ASME B31.9.
- B. Route piping parallel to building structure and maintain gradient.
- C. Install piping to conserve building space, and not interfere with use of space.
- D. Group piping whenever practical at common elevations.
- E. Sleeve pipe passing through partitions, walls and floors. Refer to Section 23 05 29.

- F. Install firestopping at fire rated construction perimeters and openings containing penetrating sleeves and piping. Refer to Section 23 05 29.
- G. Install pipe identification in accordance with Section 23 05 53.
- H. Install piping to allow for expansion and contraction without stressing pipe, joints, or connected equipment.
- I. Provide access where valves and fittings are not exposed.
- J. Slope hydronic piping and arrange systems to drain at low points. Use eccentric reducers to maintain top of pipe aligned. Provide low point drain valve and high point air relief valve where required for complete system drain and removal of air.
- K. Where pipe support members are welded to structural building framing, scrape, brush clean, and apply one coat of zinc rich primer to welds.
- L. Install valves with stems upright or horizontal, not inverted.
- M. Insulate piping and equipment; refer to Section 23 07 00.
- N. The drawings are diagrammatic and are based on one manufacturer's equipment. They should be followed as closely as possible, yet are not intended to show every item in its exact location or all the details of the equipment. Where required by job-site conditions, relocate and provide fittings, etc., as required. Any deviations from the drawings must be approved by the owner's representative.

### 3.5 PIPE LINING SYSTEM (ABI-1)

- A. Test and clean piping per manufacturer specs.
- B. Remove and replace valves and instruments to protect them from lining system.
- C. Apply coating complying with manufacturer's instructions.
- D. Provide video inspection of completed system for submittal to Owner.
- E. Recoat defective areas noted in video inspection at no cost to the Owner.

### 3.6 FIELD QUALITY CONTROL

- A. Section 01780: Contract Closeout: Field inspecting, testing, adjusting, and balancing.
- B. Test piping system in accordance with ASME B31.9.

### 3.7 SCHEDULES

- A. See Section 23 05 23 for Valves and Section 23 05 29 for Hangers and Supports.

END OF SECTION



SECTION 23 21 16

HYDRONIC PIPING SPECIALTIES

PART 1 GENERAL

1.1 SUMMARY

- A. Section Includes:
  - 1. Pressure gauges.
  - 2. Pressure gauge taps.
  - 3. Thermometers.
  - 4. Thermometer supports.
  - 5. Test plugs.(Pete's Plugs)
  - 6. Air vents.
  - 7. Strainers.
  - 8. Flow controls.
  - 9. Flow meters.
  - 10. Relief valves.
  - 11. Flexible connectors.
  - 12. Air/dirt separators.
  - 13. Expansion tank.
  - 14. Surge tank.
  
- B. Related Sections:
  - 1. Section 23 21 13 - Hydronic Piping: Execution requirements for piping connections to products specified by this section.

1.2 REFERENCES

- A. American Society of Mechanical Engineers:
  - 1. ASME B40.1 - Gauges - Pressure Indicating Dial Type - Elastic Element.
  - 2. ASME Section VIII - Boiler and Pressure Vessel Code - Pressure Vessels.
  
- B. ASTM International:
  - 1. ASTM E1 - Standard Specification for ASTM Thermometers.
  - 2. ASTM E77 - Standard Test Method for Inspection and Verification of Thermometers.
  - 3. AWWA M6 - Water Meters - Selection, Installation, Testing, and Maintenance.

1.3 PERFORMANCE REQUIREMENTS

- A. Flexible Connectors: Provide at or near motorized equipment where piping configuration does not absorb vibration.

1.4 SUBMITTALS

- A. Section 01300 - Submittals: Submittal procedures.

- B. Product Data: Submit for manufactured products and assemblies used in this Project.
  - 1. Manufacturer's data and list indicating use, operating range, total range, accuracy, and location for manufactured components.
  - 2. Submit product description, model, dimensions, component sizes, rough-in requirements, service sizes, and finishes.
  - 3. Submit schedule indicating manufacturer, model number, size, location, rated capacity, load served, and features for each piping specialty.
  - 4. Submit electrical characteristics and connection requirements.
- C. Manufacturer's Installation Instructions: Submit hanging and support methods, joining procedures, application, selection, and hookup configuration. Include pipe and accessory elevations.
- D. Manufacturer's Certificate: Certify products meet or exceed specified requirements.

#### 1.5 CLOSEOUT SUBMITTALS

- A. Section 01780 – Contract Closeout: Requirements for Submittals.
- B. Project Record Documents: Record actual locations of actual locations of components and instrumentation.
- C. Operation and Maintenance Data: Submit instructions for calibrating instruments, installation instructions, assembly views, servicing requirements, lubrication instruction, and replacement parts list.

#### 1.6 QUALIFICATIONS

- A. Manufacturer: Company specializing in manufacturing products specified in this section with minimum three years documented experience, and with service facilities within 100 miles of Project.
- B. Installer: Company specializing in performing Work of this section with minimum three years documented experience.

#### 1.7 PRE-INSTALLATION MEETINGS

- A. Section 01040 – Project Coordination: Construction Coordination.
- B. Convene minimum one week prior to commencing work of this section.

#### 1.8 DELIVERY, STORAGE, AND HANDLING

- A. Section 01630 - Product Requirements: Product storage and handling requirements.
- B. Accept piping specialties on site in shipping containers with labeling in place. Inspect for damage.
- C. Provide temporary protective coating on cast iron and steel valves.

- D. Protect systems from entry of foreign materials by temporary covers, caps and closures, completing sections of the work, and isolating parts of completed system until installation.

#### 1.9 ENVIRONMENTAL REQUIREMENTS

- A. Do not install instruments when areas are under construction, except rough in, taps, supports and test plugs.

#### 1.10 FIELD MEASUREMENTS

- A. Verify field measurements before fabrication.

#### 1.11 WARRANTY

- A. Section 01780 – Contract Closeout: Warranties and Bonds.
- B. Furnish five year manufacturer warranty for piping specialties.

#### 1.12 MAINTENANCE SERVICE

- A. Section 01780 – Contract Closeout: Maintenance service.

#### 1.13 MAINTENANCE MATERIALS

- A. Section 01780 – Contract Closeout: Spare parts and maintenance materials.
- B. Furnish two bottles of red gauge oil for static pressure gauges.

#### 1.14 EXTRA MATERIALS

- A. Section 01780 – Contract Closeout: Spare parts and maintenance products.
- B. Furnish two pressure gauges with pulsation damper dial thermometers.

### PART 2 PRODUCTS

#### 2.1 LIQUID FLOW METERS

- A. See section 23 09 00 for flow meters installed in piping system under this section

#### 2.2 PRESSURE GAUGES

- A. Gauge: ASME B40.1, with bourdon tube, rotary brass movement, brass socket, front calibration adjustment, black scale on white background.
  1. Case: Stainless Steel.
  2. Bourdon Tube: Type 316 stainless steel.
  3. Dial Size: 4-1/2 inch diameter.
  4. Mid-Scale Accuracy: One percent.

5. Manufacturer: Ashcroft Type 1009-5-02L

## 2.3 PRESSURE GAUGE TAPS

- A. Ball Valve: 316 Stainless Steel, 1/4 inch NPT for 250 psi.
- B. Pulsation Damper: Pressure snubber, brass with 1/4 inch NPT connections; Manufacturer: Ashcroft.
- C. Siphon: Steel, Schedule 40 Stainless Steel, 1/4 inch NPT angle or straight pattern.

## 2.4 BIMETAL THERMOMETERS

- A. *Thermometer: ASME B40.3, adjustable angle, all welded stainless steel construction, shatter proof glass. Provide shorter stem length for pipe 4 inches and smaller. Match stem length with the thermowell length with extension.*
  1. *Size: 5 inch scale.*
  2. *Window: Shatterproof*
  3. *Stem: Brass, 1/2 inch NPT, long.*
  4. *Accuracy: 1 percent.*
  5. *Calibration: Degrees 100F.*
  6. *Manufacturer: Ashcroft, 50-E1-60-E*

## 2.5 THERMOMETER SUPPORTS

- A. *Socket: Stainless steel thermowells with extensions for pipe insulation. See Pipe Insulation Schedule on Drawings.*
- B. *Manufacturer: Trevice 76-4XX or equal.*

## 2.6 TEMPERATURE SENSOR/TRANSMITTER

- A. See Section 23 09 00 – HVAC Instrumentation and Controls” for temperature transmitters installed in piping systems.

## 2.7 TEST PLUGS (Pete’s Plugs)

- A. 1/2 inch NPT stainless steel fitting and cap for receiving 1/8 inch outside diameter pressure and temperature probe with:
  1. Viton core for temperatures up to 400 degrees F.
  2. Provide extension when installed on insulated pipes.

## 2.8 AIR VENTS

- A. Manual Type: Short vertical sections of 2 inch diameter pipe to form air chamber, with 1/8 inch brass needle valve at top of chamber.
- B. Float Type: (AAV)

1. Stainless steel float valve and valve seat; suitable for system operating temperature and pressure; with isolating valve. See valve schedule in project drawing.

## 2.9 STRAINERS

- A. See valve specification schedule in project drawing.

## 2.10 FLEXIBLE CONNECTORS

- A. Manufacturers:
  1. Mason Industries, SF Series.
  2. Vibration Mountain and Controls
- B. Body: Piping flexible connections shall be manufactured of multiple plies of Kevlar or wire cord fabric and neoprene. Straight connections shall have one or two spheres. Connectors up to and including 1-1/2" diameter may have threaded ends. Connectors 2" and larger shall be manufactured with floating galvanized flanges recessed to lock the connector's raised face neoprene flanges.

## 2.11 AIR/DIRT SEPARATOR

- A. Manufacturers:
  1. Spirotherm, Spriovent VHN-100 SFL.
  2. Substitutions: Section 01630 – Product Requirements and Substitutions.
- B. *Equipment Tag: SB2-AS-01, SB2-AS-02*
- C. Type: Coalescing type air eliminator and dirt separator. Fabricated steel shell, rated for 150 psig working pressure, with internal copper core bundle, with venting chamber, with valved tap to flush or purge, with removable lower head for inspection and cleaning, with support legs and drain, tested and stamped in accordance with ASME Section VIII.

## 2.12 DIAPHRAGM-TYPE EXPANSION TANK

- A. Manufacturer's:
  1. Wessels
  2. Bell and Gossett
  3. Substitutions: Section 01630 - Product Requirements and Substitutions.
- B. Construction: Welded steel, tested and stamped in accordance with ASME Section VIII; supplied with National Board Form U-1, rated for working pressure of 125 psig with flexible EPDM diaphragm sealed into tank and steel support stand.
- C. Accessories: Pressure gage and air-charging fitting, tank drain; pre-charge to 30 psig.
- D. See Expansion Tank Schedule in the drawings.

## 2.13 SURGE TANK

- A. Manufacturer's:
  - 1. Wessels
  - 2. Bell and Gossett
  - 3. Substitutions: Section 01630 - Product Requirements and Substitutions.
- B. Construction: Welded steel, tested and stamped in accordance with ASME Section VIII; supplied with National Board Form U-1, rated for working pressure of 250 psig with flexible heavy duty butyl diaphragm sealed into tank and steel support stand.
- C. Accessories: Pressure gage and air-charging fitting, tank drain; pre-charge to 30 psig.
- D. See Surge Tank Schedule in the drawings.

## PART 3 EXECUTION

### 3.1 INSTALLATION - METERS

- A. Install liquid flow meters with shutoff valve on insertion meter branch.

### 3.2 INSTALLATION - THERMOMETERS AND GAUGES

- A. Install one pressure gauge for each pump, locate taps before strainers and on suction and discharge of pump; pipe to gauge.
- B. Install gauge taps in piping
- C. Install pressure gauges with pulsation dampers. Provide ball valve to isolate each gauge. Extend nipples to allow clearance from insulation.
- D. Install thermometers in piping systems in sockets in short couplings. Enlarge pipes smaller than 2-1/2 inches for installation of thermometer sockets. Allow clearance from insulation.
- E. Install gauges and thermometers in locations where they are easily read from normal operating level. Install vertical to 45 degrees off vertical.
- F. Adjust gauges and thermometers to final angle, clean windows and lenses, and calibrate to zero.

### 3.3 INSTALLATION - HYDRONIC PIPING SPECIALTIES

- A. Locate test plugs as indicated on Drawings.
- B. Where large air quantities accumulate, provide enlarged air collection standpipes.
- C. Install air vents at system high points.

- D. Install automatic air vents where indicated on drawings.
- E. Provide air separator on suction side of system circulation pump and connect to expansion tank.
- F. Provide drain and hose connection with valve on strainer blow down connection.
- G. Support pump fittings with floor mounted pipe and flange supports.
- H. Provide relief valves on pressure tanks, low-pressure side of reducing valves, heat exchangers, and expansion tanks.
- I. Select system relief valve capacity greater than make-up pressure reducing valve capacity. Select equipment relief valve capacity to exceed rating of connected equipment.
- J. Pipe relief valve outlet to nearest floor drain.
- K. Where one line vents several relief valves, make cross sectional area equal to sum of individual vent areas.
- L. Flexible connectors/expansion joints shall be installed on the equipment side of the shut off valves. Connectors shall be rated a minimum of 150 psi at 220 degrees F. Flanged equipment shall be directly connected to neoprene elbows in the size range 2-1/2” through 12” if the piping makes a 90 degree turn at twin-spheres properly pre-extended as recommended by the manufacturer to prevent additional elongation under pressure.
- M. Provide drain from air/dirt separator to nearest floor sink.

### 3.4 FIELD QUALITY CONTROL

- A. Section 01780 – Contract Closeout: Field inspecting, testing, adjusting, and balancing.

### 3.5 CLEANING

- A. Section 01780 – Contract Closeout: Requirements for cleaning

### 3.6 PROTECTION OF INSTALLED CONSTRUCTION

- A. Section 01780 – Contract Closeout: Requirements for protecting installed construction.
- B. Do not install pressure gauges until after systems are pressure tested.

### 3.7 SCHEDULES

- A. Pressure Gauge Locations are indicated on P & ID and isometric drawings
  - 1. Chilled water system.
- B. Pressure Gauge Tapping Location:
  - 1. Control valves 3/4 inch & larger - inlets and outlets.

- C. Thermometer Locations are indicated on P & ID and isometric drawings.
  - 1. Headers to central equipment.

END OF SECTION



SECTION 23 25 00

HVAC WATER TREATMENT

PART 1 GENERAL

1.1 DESCRIPTION

- A. General: Provide water treatment systems, complete, as shown, specified or required per Contract Documents, including, but not limited to, the following:
  - 1. Chilled water piping, and condenser water piping.
  - 2. Supervision of installation.
  - 3. Cleaning of piping systems.
  - 4. Start-up.
  - 5. One year's water treatment service and chemicals.
  - 6. Chemical treatment equipment chemical and service.

1.2 SUMMARY

- A. Section Includes:
  - 1. System cleaner.
  - 2. Closed system treatment (Condenser water).

1.3 PERFORMANCE REQUIREMENTS

- A. Provide system to treat water available at project site to maintain the following characteristics of water in closed steam condenser open systems:
  - 1. Hardness.
  - 2. Iron.
  - 3. Total Dissolved Solids.
  - 4. Total Alkalinity.
  - 5. Silica.
  - 6. pH.
- B. Provide for complete cleaning, flushing and passivating of chilled water, and condenser water piping system. Provide all temporary pumps, hoses, etc. as necessary

1.4 SUBMITTALS

- A. Provide product data for each piece of equipment installed in the system and for each chemical used.
- B. Provide shop drawings for control panel, including internal and external wiring diagrams, dimensions, etc.
- C. Provide operation and maintenance manuals for all equipment.
- D. Material Data Safety Sheets shall accompany all chemicals delivered to the job site.

- E. Reports:
  - 1. Start-up.
  - 2. Cleaning and flushing.
  - 3. Monthly reports.
  - 4. Shop test reports of equipment.

#### 1.5 CLOSEOUT SUBMITTALS

- A. Project Record Documents: Record actual locations of equipment and piping, including sampling points and location of chemical injectors.
- B. Operation and Maintenance Data: Submit data on chemical feed pumps, agitators, and other equipment including spare parts lists, procedures, and treatment programs. Include step by step instructions on test procedures including target concentrations.

#### 1.6 QUALITY ASSURANCE

- A. The chemical treatment program shall be administered by a firm regularly engaged in the field of water treatment with a minimum of five years experience in the immediate area of the job site location, and similar sized projects.
- B. The water treatment contractor shall have laboratory facilities, both central and field, to service the Owner's account.
- C. The water treatment contractor shall have local warehousing and will not be allowed to overstock chemical on premises.
- D. A single water treatment company shall be responsible for all products and services.
- E. Comply with the requirements of the following agencies.
  - 1. The applicable water quality control district.
  - 2. The local sanitation district or sewage agency.
  - 3. Applicable industrial waste regulations.
  - 4. Conform to OSHA Standards for the handling and storage of hazardous chemicals.
- F. Provide water treatment chemicals for circulating water systems, and equipment as defined herein and as may be required to maintain the integrity of the piping systems and mechanical equipment.
- G. The water treatment chemical and service supplier shall be a recognized specialist, active in the field of industrial water treatment, whose business is in the field of water treatment, and who has full-time personnel within the trading area of the job site.
- H. Furnish and install all equipment and material on this project in accordance with the requirements of the authority having jurisdiction, suitable for its intended use on the project, and approved by the Environmental Protection Agency (EPA).

### 1.7 QUALIFICATIONS

- A. Manufacturer: Company specializing in manufacturing products specified in this section with minimum three years experience, and with service facilities within 50 miles of Project with water analysis laboratories and full time service personnel.
- B. Installer: Company specializing in performing Work of this section with minimum three years documented experience approved by manufacturer.

### 1.8 FIELD MEASUREMENTS

- A. Verify field measurements prior to fabrication.

### 1.9 WARRANTY

- A. Furnish one year manufacturer warranty for pumps, valves and water meters.

### 1.10 MAINTENANCE SERVICE

- A. Section HR01780 – Contract Closeout: Maintenance service.
- B. Furnish monthly technical service visits, for one year starting at Date of Substantial Completion, to perform field inspections and make water analysis on site. Detail findings in writing on proper practices, chemical treating requirements and corrective actions needed. Submit two copies of field service report after each visit.
- C. Furnish laboratory and technical assistance services during this maintenance period.
- D. Furnish on site inspections of equipment during scheduled or emergency shutdown to properly evaluate success of water treatment program, and make recommendations in writing based upon these inspections.

### 1.11 MAINTENANCE MATERIALS

- A. Furnish chemicals for treatment and testing during warranty period.

## PART 2 PRODUCTS

### 2.1 ACCEPTABLE MANUFACTURERS

- A. Control equipment as specified or equal.

### 2.2 PRESTART-UP CLEANING AND FLUSHING

- A. Furnish all required pipe cleaning chemicals, chemical feed equipment, materials, and labor necessary to clean the piping as herein specified. In addition, permanently install necessary chemical injection fittings complete with stop valves and coupon racks, etc.

- B. Provide a prestart-up, non-foaming, liquid detergent cleaner for cleaning of all water systems to remove oil and foreign matter from the piping and equipment prior to the final filling of the systems. This chemical shall not be injurious to persons, piping, pipe joint compounds, packing, coils, valves, pumps and their mechanical seals, tubes or other parts of the system.
- C. Liquid alkaline compound Ondeo Nalco 2567 emulsifying cleaner to remove oil, grease, solids, and dirt. Dosage 5 gallons Nalco 2567 to 500 gallon systems. Use Nalco 2578 Nalprep passivating pre-cleaner for tower and chillers. Dosage 1 gallons per 500 gallon in the system.

### 2.3 WATER TREATMENT CONTROL TESTING EQUIPMENT

- A. Supply one year's quantity of testing chemicals to properly analyze the treated water. Provide separate test kits for each chemical used. Furnish log sheets and test instructions.

### 2.4 CLOSED SYSTEMS EQUIPMENT (CONDENSER WATER LOOPS)

- A. On each closed loop install a 5 gallon by-pass chemical feeder, 3-1/2" opening with 3/4" isolation valves across the common suction and discharge lines of the circulation pumps. Hard pipe the feeder drain to the nearest floor sink. Install feeder in location convenient for filling.

## PART 3 EXECUTION

### 3.1 TECHNICAL SERVICE AND CONTROL

- A. Water treatment equipment shall be located as indicated on the drawings.
- B. Supervise the installation of water treatment equipment.
- C. Supervise the cleaning of open and closed systems and provide a written certification of cleanliness at completion of cleaning procedure.
- D. Provide one (1) two-hour training program to the Owner's operating personnel instructing them clearly and fully on the installation, care, maintenance, testing and operation of the water treatment system. The training course shall be arranged by the contractor at the startup of the system.
- E. For a period of one year after completion of system commissioning provide the services of a fully qualified field ENGINEER for one year at no additional cost to the owner. This field ENGINEER must be a graduate chemist or chemical ENGINEER and shall be active in the water treatment field in this locale. The water treatment company shall also provide laboratory and technical assistance from fully qualified ENGINEERING staff to support the following tasks:
  - 1. Make monthly technical service visits to the installation to perform field inspections and to make water analysis on site, with sufficient complexity as to evaluate the water systems operations. Discuss findings with the Owner's personnel in writing, advising on proper practices, chemical requirements and any corrective actions needed to protect the water systems from scale, corrosion, and fouling. Copies of the field service report must be forwarded each month to the Project Manager, Architect and ENGINEER for review.

2. Make on-site inspection of equipment during scheduled or emergency outages in order to properly evaluate the success of the water treatment program and to make recommendations in writing based upon these inspections.

### 3.2 CLEANING OF PIPING SYSTEMS

- A. General: Piping systems for chilled water, condenser water and steam piping shall be flushed with chemically treated water.
- B. Supervision: Entire procedure shall be supervised by the independent chemical treatment company.
- C. Perform the cleaning after completion of piping and pressure testing and before the system is put into operation.
- D. Flush and chemically clean all piping systems, then change with chemically treated water.
- E. Do not circulate cleaning solution through cooling and heating coils, or steam traps. Provide temporary bypasses.
- F. Entire procedure shall be performed by Contractor's independent chemical cleaning company approved by Project Manager.
- G. Procedure:
  1. Flush out system for a period of not less than four hours to clear it of all loose material.
  2. Provide necessary cross-connection to loop the system and circulate water for 24 hours. During this period, install 80 mesh screens in strainers and periodically clean.
  3. Drain entire system and refill system.
  4. Meter water when refilling to determine amount of chemical required in next procedure.
  5. Add alkaline detergent cleaner, 1 gallon per 100 gallons of system capacity. Circulate water for 48 hours. During circulation, periodically clean screens as required.
  6. Flush system for approximately eight hours or until all traces of chemicals are removed. Remove 80 mesh screens from strainers. Repeat until all cleaner/passivator is removed. Independent water treatment company shall certify that "M" alkalinity is the same as City water.
  7. Inspect, remove sludge, and flush low points with clean water after cleaning process is completed. Include disassembly of components as required.
  8. Add appropriate chemical treatment for system.

3.3 CLOSED SYSTEM TREATMENT – (CONDENSER WATER)

- A. Provide one bypass feeder on each system. Install isolating and drain valves and interconnecting piping. Install around balancing valve downstream of circulating pumps.
- B. Introduce closed system treatment through bypass feeder when required or indicated by test.
- C. Install 3/4 inch water coupon rack around circulating pumps with space for 4 test specimens.

END OF SECTION

SECTION 23 65 00

COOLING TOWER

PART 1 GENERAL

1.1 SUMMARY

A. Section Includes

1. This section specifies the requirements to furnish and install the factory-assembled induced draft cooling tower.
2. General: Lifting lugs shall be provided which enable lifting by an overhead device.
3. Tower water filter system.

B. Related Sections

1. Section 23 05 13 – Common Motor Requirements for HVAC Equipment
2. Section 23 05 93 – Adjusting, Testing and Balancing
3. Section 23 05 23 – General Duty Valves and Accessories
4. Section 23 21 13 – Hydronic Piping

1.2 REFERENCES

- A. Not used in this section.

1.3 DEFINITIONS

- A. Not used in this section.

1.4 SUBMITTALS

- A. Complete layout drawings, including plan and elevations, and electrical piping connections.
- B. Submit suggested structural steel support including dimensions, sizes, and locations for mounting bolt holes. Include weight distribution drawings showing point loadings.
- C. Complete performance characteristics at specified conditions.
- D. Drift loss (percent of circulating flow).
- E. Evaporation loss (at design).
- F. Electrical power requirements.
- G. Motor manufacturer and model.

- H. Shipping weight and sizes.
- I. List the reserve capacity for the selected unit.
- J. Compliance with local building code and seismic requirements. Verify seismic design with structural engineer.

#### 1.5 QUALITY ASSURANCE

- A. Not used in this section.

#### 1.6 DELIVERY, STORAGE AND HANDLING

- A. Not used in this section.

#### 1.7 SCHEDULING AND SEQUENCING

- A. Not used in this section.

#### 1.8 WARRANTY

- A. Provide 5 year warranty of cooling tower.

### PART 2 PRODUCTS

#### 2.1 ACCEPTABLE MANUFACTURERS:

- A. Evapco, or approved equal.
- B. See cooling tower schedule in the drawing.

#### 2.2 MATERIALS

- A. Manufactured Units: Provide factory-assembled units suitable for outdoor use, induce draft counterflow, complete with sump, fan, surface and spray eliminators, and VFD motor and drive and remote VFD control panel.
  - 1. The cooling tower shall be approved for operation without the requirement for fire protection sprinkler system.
  - 2. The cooling tower shall be designed, analyzed, and construction in accordance with the latest local building code regulations for seismic calculations.
- B. Components:
  - 1. Axial Propeller Fans: Fans shall be heavy duty axial propeller type. Each fan blade shall be individually adjustable. Fan assembly to be covered with a heavy duty hot dipped galvanized steel (or stainless) wire fan guard.
  - 2. Fan Shaft: Bearings shall be heavy duty self-aligning with a minimum L-



- 10 life of 75,000 hours.
3. Fan Drive: Provide v-belt fan drives which are designed for not less than 150 percent of motor nameplate horsepower.
  4. Fan Motor: Provide TEAD fan motors with 1.15 service factor, suitable for outdoor wet service. Motor to be serviceable from outside of unit. Motor to be rated for inverter duty.
    - a. Vendor to provide motor of sufficient size to operate at 1/6 max speed.
  5. Surface Section: The heat transfer casing sections shall be removable from the pan-fan section to facilitate rigging. Each section shall include serpentine, PVC wet deck surface below a spray-type water distribution system, all encased by galvanized steel panels with removable sectional eliminators at the top. The PVC sheets shall be impervious to rot, decay, fungus or biological attack. The surface shall be manufactured and performance tested by the cooling tower manufacturer to assure single source responsibility and control of the final product. Fill to be suitable for water temperature up to 130°F.
  6. Water Distribution: Water shall be distributed evenly over the tower fill area by a water distribution system consisting of header and spray branches of Schedule 40 PVC pipe with large orifice plastic distribution nozzles. The branches and plastic spray nozzles shall be held in place by snap-in rubber grommets providing quick removal of individual nozzles or complete branches for cleaning or flushing. The header shall include provisions for measuring spray pressure externally.
    - a. A gravity fed distribution basin shall be 304 stainless steel.
    - b. All external piping shall follow project piping specifications shown on the piping schedule drawing (no PVC external to the tower).
  7. Water Makeup Valve: Each cooling tower shall be provided with a brass float valve on the makeup water connection. It will be actuated by an adjustable, plastic float.
  8. Eliminators: The eliminators shall be removable in easily handled sections. They shall direct discharge air away from the fans and limit drift loss to less than the amount specified on the attached data sheet.
  9. Basin: The pan and strainers shall be constructed of 304 stainless steel. Accessories to include overflow, drain, and anti-vortexing hood.
  10. Finish: Steel components shall be ASTM G2235 hot dipped galvanized steel with edges protected with zinc rich compound.
  11. Removable air inlet louver framework and access door shall be stainless steel.
  12. The selected unit shall provide 3 percent reserve capacity over and above those design conditions shown on the following data sheets, adjusted for all accessories listed.

### 2.3 ACCESSORIES:

- A. Provide spring isolator per Section 23 05 48.

- B. Vibration Cutout Switch shall de-energize fan motors upon excessive vibration. The reset shall be in an accessible location.
- C. Enclosure: The cooling tower controls shall be provided with a waterproof Remote NEMA 3R enclosure. Enclosure shall be pre-wired with the following electrical devices and control components:
  - 1. 208/3/60 connection.
  - 2. Electrical disconnect for the tower fan motor.
  - 3. 120 volt GFCI convenience outlet
  - 4. 120 volt to 24-volt control transformer for the capacity control damper actuator and sensor circuit.
  - 5. Low water level switches with auxiliary dry contact.
  - 6. Water temperature transmitter.
- D. Controls
  - 1. Sump water temperature sensor transmitter switch
  - 2. Low water level switch
  - 3. Make up water float valve
  - 4. Instruments shall accept 4-20 MA control signal.
  - 5. Vendor to provide and land all tower instruments in a terminal box. Panel to be NEMA 3R. All wires shall be tagged with device name. Shielding on analog signal wire shall have separate ground terminals.
- E. See Drawing M1 and M2.

#### 2.4 Tower Water Filter System

- A. Lakos Separator System Model TCI-0100-SRV with Inlet/outlet Valve Kit and Indicator Contacts
  - 1. 100 GPM @ 100 FT TDH, 5HP, TEFC, 208V/3Ph/60Hz Pump Motor
  - 2. 3" Flanged inlet, 2" Grooved outlet
  - 3. Close-Coupled Bronze Fitted Cast Iron Construction Pump
  - 4. NEMA 4X, UL Listed Electrical Control Panel with Pump Thermal Overload Protection, H-O-A, Fused Disconnect Factory Wired.
  - 5. Mounted on Structural Steel Baseplate, Primed and Finish Coated with Enamel Paint
  - 6. Differential Pressure Indicator with Dry Electric Contact for Solids Recovery Vessel
  - 7. Solids Recovery Vessel with 25 Micron Bag Filter

### PART 3 EXECUTION

#### 3.1 FACTORY TEST

- A. The cooling tower provided shall be labeled and certified in accordance with CTI standard STD-201 to conclusively confirm the performance requirements specified in the data sheet provided at the end of this section.

3.2 INSTALLATION:

- A. Install in accordance with manufacturer's instructions.
- B. Controls and wiring.
  - 1. Provide pre-wired controls inside remotely located NEMA 3R enclosure, 24"x30".
  - 2. Instrument voltages shall be 24-V DC.

END OF SECTION

SECTION 26 05 00

COMMON WORK RESULTS FOR ELECTRICAL

PART 1 GENERAL

1.1 SUMMARY

- A. Section includes:
  - 1. Conduit and wire for lights and receptacles in tunnels.
  - 2. Conduit and wire for medium voltage.
  - 3. Medium voltage switch.
  - 4. Unit substation.
  - 5. Panel boards.
  - 6. Low voltage distribution transformer.
  - 7. Conduit and wire for pumps.
  - 8. Other miscellaneous electrical as noted on drawings

1.2 SYSTEM DESCRIPTION

- A. Lighting and receptacles in tunnels.
- B. Identify location of electrical components.
- C. Install medium voltage switch.
- D. Install 2000 kVA unit substation: 12.47 kV primary dry transformer; 480Y/277V secondary.
- E. Install conduit and wires.

1.3 SUBMITTALS

- A. Section 01300 – Submittals

PART 2 PRODUCTS

- A. Section 26 05 19 through 26 52 00, inclusive.

PART 3 EXECUTION

3.1 EXISTING WORK

- A. Provide temporary wiring and connections to maintain existing systems in service during construction as necessary. Coordinate with owner.

- B. When performing work on energized equipment or circuits, use personnel experienced and trained in similar operations.
- C. Remove, relocate, and extend existing installations to accommodate new construction.
- D. Repair adjacent construction and finishes damaged during demolition and extension work.

### 3.2 INSTALLATION

- A. Section 26 05 19 through 26 52 00, inclusive.

END OF SECTION

SECTION 26 05 19

LOW-VOLTAGE ELECTRICAL POWER CONDUCTORS AND CABLES

PART 1 GENERAL

1.1 SUMMARY

- A. Section includes building wire and cable; and wiring connectors and connections.
- B. Related Sections:
  - 1. Section 02 41 26 – Selective Electrical Demolition
  - 2. Section 26 05 33 - Raceway and Boxes.
  - 3. Section 26 05 53 - Identification for Electrical Systems.

1.2 REFERENCES

- A. International Electrical Testing Association:
  - 1. NETA ATS - Acceptance Testing Specifications for Electrical Power Distribution Equipment and Systems.
- B. National Fire Protection Association:
  - 1. NFPA 70 - National Electrical Code.
  - 2. NFPA 262 - Standard Method of Test for Flame Travel and Smoke of Wires and Cables for Use in Air-Handling Spaces.
- C. Underwriters Laboratories, Inc.:
  - 1. UL 1277 - Standard for Safety for Electrical Power and Control Tray Cables with Optional Optical-Fiber Members.

1.3 SYSTEM DESCRIPTION

- A. Product Requirements: Provide products as follows:
  - 1. Stranded conductor for feeders and branch circuits 10 AWG and smaller.
  - 2. Stranded conductors for control circuits.
  - 3. Conductor not smaller than 12 AWG for power and lighting circuits.
  - 4. Conductor not smaller than 16 AWG for control circuits.
  - 5. Increase wire size in branch circuits to limit voltage drop to a maximum of 2.5 percent.
- B. Wiring Methods: Provide the following wiring methods:
  - 1. Concealed Dry Interior Locations: Use only Type THHN/THWN insulation, in raceway.
  - 2. Exposed Dry Interior Locations: Use only Type THHN/THWN insulation, in raceway.
  - 3. Above Accessible Ceilings: Use only Type THHN/THWN insulation, in raceway.

4. Wet or Damp Interior Locations: Use only Type THHN/THWN insulation, in raceway.
5. Exterior Locations: Use only Type XHHW insulation, in raceway.
6. Underground Locations: Use only Type XHHW insulation, in raceway.

#### 1.4 DESIGN REQUIREMENTS

- A. Conductor sizes are based on copper.

#### 1.5 SUBMITTALS

- A. Section 01300 – Submittals.
- B. Product Data: Submit for wire and each cable assembly type.
- C. Test Reports: Indicate procedures and values obtained.

#### 1.6 QUALITY ASSURANCE

- A. Section 01400 – Quality Requirements.
- B. Perform Work in accordance with Municipality of Portland, OR requirements.

#### 1.7 QUALIFICATIONS

- A. Manufacturer: Company specializing in manufacturing products specified in this section with minimum three years experience.

#### 1.8 FIELD MEASUREMENTS

- A. Verify field measurements are as indicated on Drawings.

#### 1.9 COORDINATION

- A. Where wire and cable destination is indicated and routing is not shown, determine routing and lengths required.
- B. Wire and cable routing indicated is approximate unless dimensioned. Include wire and cable lengths within 20 ft (6000 mm) of length shown.

### PART 2 PRODUCTS

#### 2.1 BUILDING WIRE

- A. Manufacturers:
  1. American Insulated Wire Corp.
  2. General Cable Co.
  3. Southwire
  4. Superior Essex

5. Okonite
  6. Or approved equal
- B. Product Description: Single conductor insulated wire.
- C. Conductor: Copper.
- D. Insulation Voltage Rating: 600 volts.
- E. Insulation Temperature Rating: 75 degrees C.
- F. Insulation Material: Thermosetting.
- 2.2 ARMORED CABLE (Type AC)
- A. Manufacturer: Okonite, Southwire, or approved equal.
- B. Cable: (insulated conductors in a flexible metal enclosure) - suitable for installation indoor, in cable tray, in raceways, in dry locations; exposed or concealed.
1. Power cables shall consist of insulated annealed copper conductors wrapped with an overall metal jacket.
  2. Suitable for 600 Volts or less in dry locations at temperatures not to exceed 90°C.
  3. Insulation Temperature Rating: 75 90 deg C.
- 2.3 WIRING CONNECTORS
- A. Solderless Pressure Connectors:
1. Wire sizes up to and including #10AWG: Compression or crimp terminals shall be similar to “Sta-Kon” (by Thomas & Betts).
  2. Wire sizes #8 AWG and larger: Connectors shall be compression-type. Use manufacturer’s recommended tooling.
  3. Pigtail splices for wire sizes up to AWG including #10 AWG may be made with hand twist wire-nuts similar to “Skotchlok” by 3M Company.
  4. Substitutions: Section 01630 – Product Requirements and Substitutions.
- B. Compression Connectors:
1. Up to #4/0 AWG short-barrel single-hole lugs - similar to “Color-Keyed” by Thomas & Betts.
  2. Short-barrel two-hole lugs, similar to “Color-Keyed” by Thomas & Betts.
  3. For 250 kcmil and larger – Long barrel single-holed or two-holed lugs - similar to “Color-Keyed” by Thomas & Betts.
  4. Two-way connectors (splices) – Similar to “Color-Keyed” by Thomas & Betts.
  5. Substitutions: Section 01630 – Product Requirements and Substitutions.
- 2.4 TERMINATIONS
- A. Terminal Lugs for Wires #6 AWG and Smaller: Solderless, compression type copper.
- B. Lugs for Wires #4 AWG and Larger: Compression type copper, with insulating sealing collars.



## PART 3 EXECUTION

### 3.1 EXAMINATION

- A. Verify mechanical work likely to damage wire and cable has been completed.
- B. Verify raceway installation is complete and supported.

### 3.2 PREPARATION

- A. Completely and thoroughly swab raceway before installing wire.

### 3.3 EXISTING WORK

- A. Remove exposed abandoned wire and cable as per Section 02 41 26. Patch surfaces where removed cables pass through building finishes.
- B. Disconnect abandoned circuits and remove circuit wire and cable. Remove abandoned boxes when wire and cable servicing boxes is abandoned and removed. Install blank cover for abandoned boxes not removed.
- C. Provide access to existing wiring connections remaining active and requiring access. Modify installation or install access panel.
- D. Extend existing circuits using materials and methods compatible with existing electrical installations, or as specified.
- E. Clean and repair existing wire and cable remaining or wire and cable to be reinstalled.

### 3.4 INSTALLATION

- A. Route wire and cable to meet Project conditions.
- B. Neatly train and lace wiring inside boxes, equipment, and panelboards.
- C. Identify and color code wire and cable under provisions of Section 26 05 53.
- D. Special Techniques--Building Wire in Raceway:
  - 1. Pull conductors into raceway at same time.
  - 2. Install building wire #4 AWG and larger with pulling equipment.
- E. Special Techniques - Cable:
  - 1. Protect exposed cable from damage.
  - 2. Use suitable cable fittings and connectors.
- F. Special Techniques - Wiring Connections:
  - 1. Clean conductor surfaces before installing lugs and connectors.
  - 2. Make splices, taps, and terminations to carry full ampacity of conductors with no perceptible temperature rise.

3. Tape uninsulated conductors and connectors with electrical tape to 150 percent of insulation rating of conductor.
  4. Install split bolt connectors for copper conductor splices and taps, #6 AWG and larger.
  5. Install solderless pressure connectors with insulating covers for copper conductor splices and taps, #8 AWG and smaller.
  6. Install insulated spring wire connectors with plastic caps for copper conductor splices and taps, #10 AWG and smaller.
- G. Install stranded conductors for branch circuits #10 AWG and smaller. Install crimp on fork terminals for device terminations. Do not place bare stranded conductors directly under screws.
- H. Install terminal lugs on ends of 600 volt wires unless lugs are furnished on connected device, such as circuit breakers.
- I. Size lugs in accordance with manufacturer's recommendations terminating wire sizes. Install 2-hole type lugs to connect wires #4 AWG and larger to copper bus bars.
- J. For terminal lugs fastened together such as on motors, transformers, and other apparatus, or when space between studs is small enough that lugs can turn and touch each other, insulate for dielectric strength of 2-1/2 times normal potential of circuit.
- K. Do not install wire terminals, such as ring or spade terminals, for wire termination in components utilizing compression terminal blocks, e.g. motor control center, variable frequency drives, etc.
- L. Armored cable may be used for lighting fixture connection.

### 3.5 WIRE COLOR

- A. General: See Section 26 05 53 – Electrical Identification.

### 3.6 FIELD QUALITY CONTROL

- A. Section 01400 - Quality Requirements
- B. Inspect and test in accordance with NETA ATS, except Section 4.
- C. Perform inspections and tests listed in NETA ATS, Section 7.3.1.

END OF SECTION

SECTION 26 05 26

GROUNDING AND BONDING FOR ELECTRICAL SYSTEMS

PART 1 GENERAL

1.1 SUMMARY

- A. Section Includes:
  - 1. Rod electrodes.
  - 2. Wire.
  - 3. Grounding well components.
  - 4. Mechanical connectors.
  - 5. Exothermic connections.

1.2 REFERENCES

- A. Institute of Electrical and Electronics Engineers:
  - 1. IEEE 142 - Recommended Practice for Grounding of Industrial and Commercial Power Systems.
- B. International Electrical Testing Association:
  - 1. NETA ATS - Acceptance Testing Specifications for Electrical Power Distribution Equipment and Systems.
- C. National Fire Protection Association:
  - 1. NFPA 70 - National Electrical Code.

1.3 SYSTEM DESCRIPTION

- A. Grounding systems use the following elements as grounding electrodes:
  - 1. Metal building frame.
  - 2. Concrete-encased electrode.
  - 3. Rod electrode.

1.4 SUBMITTALS

- A. Section 01300 - Submittals: Requirements for submittals.
- B. Product Data: Submit data on grounding electrodes and connections.

1.5 CLOSEOUT SUBMITTALS

- A. Section 01780 – Contract Closeout: Requirements for submittals.

1.6 QUALITY ASSURANCE

- A. Provide grounding materials conforming to requirements of NEC, IEEE 142, and UL labeled.

- B. Perform Work in accordance with City of Portland standard.
- C. Maintain one copy of each document on site.

#### 1.7 QUALIFICATIONS

- A. Installer: Company specializing in performing work of this section with minimum 3 years experience.

#### 1.8 DELIVERY, STORAGE, AND HANDLING

- A. Section 01630 - Product Requirements and Substitutions: Requirements for transporting, handling, storing, and protecting products.
- B. Accept materials on site in original factory packaging, labeled with manufacturer's identification.
- C. Protect from weather and construction traffic, dirt, water, chemical, and mechanical damage, by storing in original packaging.

#### 1.9 COORDINATION

- A. Section 01040 – Project Coordination: Requirements for coordination.
- B. Complete grounding and bonding of building reinforcing steel prior concrete placement.

### PART 2 PRODUCTS

#### 2.1 ROD ELECTRODES

- A. Manufacturers:
  - 1. Erico, Inc.
  - 2. O-Z Gedney Co.
  - 3. Thomas & Betts, Electrical
  - 4. Or approved equal.
- B. Product Description:
  - 1. Material: Copper-clad steel.
  - 2. Diameter: 5/8 inch.
  - 3. Length: 10 feet feet.
- C. Connector: Connector for exothermic welded connection or U-bolt clamp.

#### 2.2 WIRE

- A. Material: Stranded copper.
- B. Grounding Electrode Conductor: Copper conductor bare.

- C. Bonding Conductor: Copper conductor bare.

### 2.3 GROUNDING WELL COMPONENTS

- A. Well Pipe: 8 inches NPS by 24 inches long concrete pipe with belled end.
- B. Well Cover: Cast iron with legend "GROUND" embossed on cover.

### 2.4 MECHANICAL CONNECTORS

- A. Manufacturers:
  1. Erico, Inc.
  2. ILSCO Corporation
  3. O-Z Gedney Co.
  4. Thomas & Betts, Electrical
  5. Or approved equal.
- B. Description: Bronze connectors, suitable for grounding and bonding applications, in configurations required for particular installation.

### 2.5 EXOTHERMIC CONNECTIONS

- A. Manufacturers:
  1. Copperweld, Inc.
  2. ILSCO Corporation
  3. O-Z Gedney Co.
  4. Thomas & Betts, Electrical
  5. Or approved equal.
- B. Product Description: Exothermic materials, accessories, and tools for preparing and making permanent field connections between grounding system components.

## PART 3 EXECUTION

### 3.1 EXAMINATION

- A. Section 01040 – Project Coordination: Verification of existing conditions before starting work.
- B. Verify final backfill and compaction has been completed before driving rod electrodes.

### 3.2 PREPARATION

- A. Remove paint, rust, mill oils, surface contaminants at connection points.

### 3.3 EXISTING WORK

- A. Modify existing grounding system to maintain continuity to accommodate renovations.

- B. Extend existing grounding system using materials and methods compatible with existing electrical installations, or as specified.

### 3.4 INSTALLATION

- A. Install in accordance with IEEE 142.
- B. Install rod electrodes at locations as indicated on Drawings.
- C. Install grounding and bonding conductors concealed from view.
- D. Install grounding well pipe with cover at rod locations as indicated on Drawings. Install well pipe top flush with finished grade.
- E. Bond together metal siding not attached to grounded structure; bond to ground.
- F. Bond together each metallic raceway, pipe, duct and other metal objects.
- G. Equipment Grounding Conductor: Install separate, insulated conductor within each feeder and branch circuit raceway. Terminate each end on suitable lug, bus, or bushing.
- H. Permanently ground entire light and power system in accordance with NEC, including service equipment, distribution panels, lighting panelboards, switch and starter enclosures, motor frames, grounding type receptacles, and other exposed non-current carrying metal parts of electrical equipment.
- I. Install branch circuits feeding isolated ground receptacles with separate insulated grounding conductor, connected only at isolated ground receptacle, ground terminals, and at ground bus of serving panel.
- J. Accomplish grounding of electrical system by using insulated grounding conductor installed with feeders and branch circuit conductors in conduits. Size grounding conductors in accordance with NEC. Install from grounding bus of serving panel to ground bus of served panel, grounding screw of receptacles, lighting fixture housing, light switch outlet boxes or metal enclosures of service equipment. Ground conduits by means of grounding bushings on terminations at panelboards with installed number 12 conductor to grounding bus.
- K. Grounding electrical system using continuous metal raceway system enclosing circuit conductors in accordance with NEC.
- L. Permanently attach equipment and grounding conductors prior to energizing equipment.

### 3.5 FIELD QUALITY CONTROL

- A. Section 01780 – Contract Closeout: Field inspecting, testing, adjusting, and balancing.
- B. Inspect and test in accordance with NETA ATS, except Section 4.
- C. Grounding and Bonding: Perform inspections and tests listed in NETA ATS, Section 7.13.

- D. Perform continuity testing in accordance with IEEE 142.
- E. When improper grounding is found on receptacles, check receptacles in entire project and correct. Perform retest.

END OF SECTION

SECTION 26 05 29

HANGERS AND SUPPORTS FOR ELECTRICAL SYSTEMS

PART 1 GENERAL

1.1 SUMMARY

- A. Section Includes:
  - 1. Conduit supports.
  - 2. Formed steel channel.
  - 3. Spring steel clips.
  - 4. Firestopping relating to electrical work.
  - 5. Firestopping accessories.
  - 6. Equipment bases and supports.
- B. Related Sections:
  - 1. Section 03 30 00 - Cast-In-Place Concrete.

1.2 REFERENCES

- A. ASTM International:
  - 1. ASTM E84 - Standard Test Method for Surface Burning Characteristics of Building Materials.
  - 2. ASTM E119 - Standard Test Methods for Fire Tests of Building Construction and Materials.
  - 3. ASTM E814 - Standard Test Method for Fire Tests of Through-Penetration Fire Stops.
  - 4. ASTM E1966 - Standard Test Method for Fire-Resistive Joint Systems.
- B. FM Global:
  - 1. FM - Approval Guide, A Guide to Equipment, Materials & Services Approved By Factory Mutual Research For Property Conservation.
- C. National Fire Protection Association:
  - 1. NFPA 70 - National Electrical Code.
- D. Underwriters Laboratories Inc.:
  - 1. UL 263 - Fire Tests of Building Construction and Materials.
  - 2. UL 723 - Tests for Surface Burning Characteristics of Building Materials.
  - 3. UL 1479 - Fire Tests of Through-Penetration Firestops.
  - 4. UL 2079 - Tests for Fire Resistance of Building Joint Systems.
  - 5. UL - Fire Resistance Directory.

1.3 DEFINITIONS

- A. Firestopping (Through-Penetration Protection System): Sealing or stuffing material or assembly placed in spaces between and penetrations through building materials to arrest movement of fire, smoke, heat, and hot gases through fire rated construction.



#### 1.4 PERFORMANCE REQUIREMENTS

- A. Firestopping: Conform to applicable code UL for fire resistance ratings and surface burning characteristics.
- B. Firestopping: Provide certificate of compliance from authority having jurisdiction indicating approval of materials used.

#### 1.5 SUBMITTALS

- A. Section 01300 - Submittals
- B. Shop Drawings: Indicate system layout with location and detail of trapeze hangers.
- C. Product Data:
  - 1. Hangers and Supports: Submit manufacturers catalog data including load capacity.
  - 2. Firestopping: Submit data on product characteristics, performance and limitation criteria.
- D. Firestopping Schedule: Submit schedule of opening locations and sizes, penetrating items, and required listed design numbers to seal openings to maintain fire resistance rating of adjacent assembly.
- E. Design Data: Indicate load carrying capacity of trapeze hangers and hangers and supports.
- F. Manufacturer's Installation Instructions:
  - 1. Hangers and Supports: Submit special procedures and assembly of components.
  - 2. Firestopping: Submit preparation and installation instructions.
- G. Manufacturer's Certificate: Certify products meet or exceed specified requirements.
- H. Engineering Judgements: For conditions not covered by UL listed designs, submit judgements by licensed professional engineer suitable for presentation to authority having jurisdiction for acceptance as meeting code fire protection requirements.

#### 1.6 QUALITY ASSURANCE

- A. Section 01400 – Quality Requirements
- B. Through Penetration Firestopping of Fire Rated Assemblies: UL 1479 or ASTM E814 with 0.10 inch water gage minimum positive pressure differential to achieve fire F-Ratings and temperature T-Ratings as indicated on Drawings, but not less than 1-hour.
  - 1. Wall Penetrations: Fire F-Ratings as indicated on Drawings, but not less than 1-hour.
  - 2. Floor Penetrations: Fire F-Ratings and temperature T-Ratings as indicated on Drawings, but not less than 1-hour.
    - a. Floor Penetrations Within Wall Cavities: T-Rating is not required.

- C. Through Penetration Firestopping of Non-Fire Rated Floor and Roof Assemblies: Materials to resist free passage of flame and products of combustion.
  - 1. Noncombustible Penetrating Items: Noncombustible materials for penetrating items connecting maximum of three stories.
  - 2. Penetrating Items: Materials approved by authorities having jurisdiction for penetrating items connecting maximum of two stories.
- D. Fire Resistant Joints in Fire Rated Floor, Roof, and Wall Assemblies: ASTM E1966 or UL 2079 to achieve fire resistant rating as indicated on Drawings for assembly in which joint is installed.
- E. Fire Resistant Joints Between Floor Slabs and Exterior Walls: ASTM E119 with 0.10 inch water gage minimum positive pressure differential to achieve fire resistant rating as indicated on Drawings for floor assembly.
- F. Surface Burning Characteristics: 25/450 flame spread/smoke developed index when tested in accordance with ASTM E84.

#### 1.7 QUALIFICATIONS

- A. Manufacturer: Company specializing in manufacturing Products specified in this section with minimum three years experience.
- B. Installer: Company specializing in performing work of this section with minimum 3 years experience.

#### 1.8 DELIVERY, STORAGE, AND HANDLING

- A. Section 01630 – Product Requirements and Substitutions: Product Delivery, Storage, and Handling.
- B. Accept materials on site in original factory packaging, labeled with manufacturer's identification.
- C. Protect from weather and construction traffic, dirt, water, chemical, and mechanical damage, by storing in original packaging.

#### 1.9 ENVIRONMENTAL REQUIREMENTS

- A. Do not apply firestopping materials when temperature of substrate material and ambient air is below 60 degrees F.
- B. Maintain this minimum temperature before, during, and for minimum 3 days after installation of firestopping materials.
- C. Provide ventilation in areas to receive solvent cured materials.

## PART 2 PRODUCTS

### 2.1 CONDUIT SUPPORTS

- A. Manufacturers:
  - 1. Allied Tube & Conduit Corp.
  - 2. Electroline Manufacturing Company
  - 3. O-Z Gedney Co.
- B. Hanger Rods: Threaded high tensile strength galvanized carbon steel with free running threads.
- C. Beam Clamps: Malleable Iron, with tapered hole in base and back to accept either bolt or hanger rod. Set screw: hardened steel.
- D. Conduit clamps for trapeze hangers: Galvanized steel, notched to fit trapeze with single bolt to tighten.
- E. Conduit clamps - general purpose: One hole malleable iron for surface mounted conduits.
- F. Cable Ties: High strength nylon temperature rated to 185 degrees F. Self locking.

### 2.2 FORMED STEEL CHANNEL

- A. Manufacturers:
  - 1. Allied Tube & Conduit Corp.
  - 2. B-Line Systems
  - 3. Unistrut Corp.
- B. Product Description: Galvanized 12 gage thick steel. With holes 1-1/2 inches on center.

### 2.3 FIRESTOPPING

- A. Manufacturers:
  - 1. Dow Corning Corp. Model.
  - 2. Fire Trak Corp. Model.
  - 3. 3M fire Protection Products Model.
- B. Product Description: Different types of products by multiple manufacturers are acceptable as required to meet specified system description and performance requirements; provide only one type for each similar application.
  - 1. Silicone Firestopping Elastomeric Firestopping: Multiple component silicone elastomeric compound and compatible silicone sealant.
  - 2. Foam Firestopping Compounds: Multiple component foam compound.
  - 3. Formulated Firestopping Compound of Incombustible Fibers: Formulated compound mixed with incombustible non-asbestos fibers.
- C. Color: As selected from manufacturer's full range of colors.

## 2.4 FIRESTOPPING ACCESSORIES

- A. Primer: Type recommended by firestopping manufacturer for specific substrate surfaces and suitable for required fire ratings.
- B. Dam Material: Permanent:
  - 1. Mineral fiberboard.
  - 2. Sheet metal.
  - 3. Alumina silicate fire board.
- C. Installation Accessories: Provide clips, collars, fasteners, temporary stops or dams, and other devices required to position and retain materials in place.
- D. General:
  - 1. Furnish UL listed products or products tested by independent testing laboratory.
  - 2. Select products with rating not less than rating of wall or floor being penetrated.
- E. Non-Rated Surfaces:
  - 1. Stamped steel, chrome plated, hinged, split ring escutcheons or floor plates or ceiling plates for covering openings in occupied areas where conduit is exposed.
  - 2. For exterior wall openings below grade, furnish modular mechanical type seal consisting of interlocking synthetic rubber links shaped to continuously fill annular space between conduit and cored opening or water-stop type wall sleeve.

## PART 3 EXECUTION

### 3.1 EXAMINATION

- A. Section 01040 – Project Coordination: Construction Coordination.
- B. Verify openings are ready to receive firestopping.

### 3.2 PREPARATION

- A. Clean substrate surfaces of dirt, dust, grease, oil, loose material, or other matter affecting bond of firestopping material.
- B. Remove incompatible materials affecting bond.
- C. Install damming materials to arrest liquid material leakage.
- D. Obtain permission from Architect/Engineer before using powder-actuated anchors.
- E. Do not drill or cut structural members.

### 3.3 INSTALLATION - HANGERS AND SUPPORTS

- A. Anchors and Fasteners:
  - 1. Concrete Structural Elements: Provide expansion anchors.

2. Steel Structural Elements: Provide beam clamps and welded fasteners.
  3. Concrete Surfaces: Provide self-drilling anchors and expansion anchors.
  4. Hollow Masonry, Plaster, and Gypsum Board Partitions: Provide toggle bolts and hollow wall fasteners.
  5. Solid Masonry Walls: Provide expansion anchors and self-drilling inserts.
  6. Sheet Metal: Provide sheet metal screws.
  7. Wood Elements: Provide wood screws.
- B. Inserts:
1. Install inserts for placement in concrete forms.
  2. Install inserts for suspending hangers from reinforced concrete slabs and sides of reinforced concrete beams.
  3. Provide hooked rod to concrete reinforcement section for inserts carrying pipe over 4 inches.
  4. Where concrete slabs form finished ceiling, locate inserts flush with slab surface.
  5. Where inserts are omitted, drill through concrete slab from below and provide through-bolt with recessed square steel plate and nut above slab.
- C. Install conduit and raceway support and spacing in accordance with NEC.
- D. Do not fasten supports to pipes, ducts, mechanical equipment, or conduit.
- E. Install multiple conduit runs on common hangers.
- F. Supports:
1. Fabricate supports from structural steel or formed steel channel. Install hexagon head bolts to present neat appearance with adequate strength and rigidity. Install spring lock washers under nuts.

### 3.4 INSTALLATION - FIRESTOPPING

- A. Install material at fire rated construction perimeters and openings containing penetrating sleeves, piping, ductwork, conduit and other items, requiring firestopping.
- B. Apply primer where recommended by manufacturer for type of firestopping material and substrate involved, and as required for compliance with required fire ratings.
- C. Apply firestopping material in sufficient thickness to achieve required fire and smoke rating, to uniform density and texture.
- D. Place foamed material in layers to ensure homogenous density, filling cavities and spaces. Place sealant to completely seal junctions with adjacent dissimilar materials.
- E. Remove dam material after firestopping material has cured.
- F. Fire Rated Surface:
  1. Seal opening at floor, as follows:
    - a. Install sleeve through opening and extending beyond minimum of 1 inch on both sides of building element.

- b. Size sleeve allowing minimum of 1 inch void between sleeve and building element.
    - c. Pack void with backing material.
    - d. Seal ends of sleeve with UL listed fire resistive silicone compound to meet fire rating of structure penetrated.
  2. Where conduit penetrates fire rated surface, install firestopping product in accordance with manufacturer's instructions.
- G. Non-Rated Surfaces:
  1. Seal opening through non-fire rated wall, floor, and ceiling, as follows:
    - a. Install sleeve through opening and extending beyond minimum of 1 inch on both sides of building element.
    - b. Size sleeve allowing minimum of 1 inch void between sleeve and building element.
    - c. Install type of firestopping material recommended by manufacturer.
  2. Install escutcheons floor plates or ceiling plates where conduit, penetrates non-fire rated surfaces in occupied spaces. Occupied spaces include rooms with finished ceilings and where penetration occurs below finished ceiling.
  3. Exterior wall openings below grade: Assemble rubber links of mechanical seal to size of conduit and tighten in place, in accordance with manufacturer's instructions.

### 3.5 FIELD QUALITY CONTROL

- A. Inspect installed firestopping for compliance with specifications and submitted schedule.

### 3.6 CLEANING

- A. Section 01780 – Contract Closeout: Requirements for cleaning.
- B. Clean adjacent surfaces of firestopping materials.

### 3.7 PROTECTION OF FINISHED WORK

- A. Section 01780 – Contract Closeout: Requirements for protecting finished Work.
- B. Protect adjacent surfaces from damage by material installation.

END OF SECTION

SECTION 26 05 33

RACEWAY AND BOXES FOR ELECTRICAL SYSTEMS

PART 1 GENERAL

1.1 SUMMARY

- A. Section includes conduit and tubing, surface raceways, wireways, outlet boxes, pull and junction boxes, and handholes.
- B. Related Sections:
  - 1. Section 26 05 29 - Hangers and Supports for Electrical Systems.
  - 2. Section 26 05 53 - Identification for Electrical Systems.
  - 3. Section 26 27 26 - Wiring Devices.

1.2 UNIT PRICE - MEASUREMENT AND PAYMENT

- A. Raceway:
  - 1. Basis of Measurement: By linear foot.
  - 2. Basis of Payment: Includes materials, delivery, handling, and installing.
- B. Boxes:
  - 1. Basis of Measurement: By cubic foot.
  - 2. Basis of Payment: Includes materials, delivery, handling, and installing.

1.3 REFERENCES

- A. American National Standards Institute:
  - 1. ANSI C80.1 - Rigid Steel Conduit, Zinc Coated.
  - 2. ANSI C80.3 - Specification for Electrical Metallic Tubing, Zinc Coated.
  - 3. ANSI C80.5 - Aluminum Rigid Conduit - (ARC).
- B. National Electrical Manufacturers Association:
  - 1. NEMA 250 - Enclosures for Electrical Equipment (1000 Volts Maximum).
  - 2. NEMA FB 1 - Fittings, Cast Metal Boxes, and Conduit Bodies for Conduit and Cable Assemblies.
  - 3. NEMA OS 1 - Sheet Steel Outlet Boxes, Device Boxes, Covers, and Box Supports.
  - 4. NEMA OS 2 - Nonmetallic Outlet Boxes, Device Boxes, Covers, and Box Supports.
  - 5. NEMA RN 1 - Polyvinyl Chloride (PVC) Externally Coated Galvanized Rigid Steel Conduit and Intermediate Metal Conduit.
  - 6. NEMA TC 2 - Electrical Polyvinyl Chloride (PVC) Tubing and Conduit.
  - 7. NEMA TC 3 - PVC Fittings for Use with Rigid PVC Conduit and Tubing.

#### 1.4 SYSTEM DESCRIPTION

- A. Raceway and boxes located as indicated on Drawings, and at other locations required for splices, taps, wire pulling, equipment connections, and compliance with regulatory requirements. Raceway and boxes are shown in approximate locations unless dimensioned. Provide raceway to complete wiring system.
- B. Wet and Damp Locations: Provide rigid steel or aluminum conduit, intermediate metal conduit, electrical metallic tubing, and thickwall nonmetallic conduit. Provide cast metal or nonmetallic outlet, junction, and pull boxes. Provide flush mounting outlet box in finished areas.
- C. Concealed Dry Locations: Provide rigid steel conduit. Provide sheet-metal boxes. Provide flush mounting outlet box in finished areas. Provide hinged enclosure for large pull boxes.
- D. Exposed Dry Locations: Provide rigid steel conduit, intermediate metal conduit and, electrical metallic tubing. Provide sheet-metal boxes. Provide flush mounting outlet box in finished areas. Provide hinged enclosure for large pull boxes.

#### 1.5 DESIGN REQUIREMENTS

- A. Minimum Raceway Size: 3/4 inch unless otherwise specified.

#### 1.6 SUBMITTALS

- A. Product Data: Submit for the following:
  - 1. Liquidtight flexible metal conduit.
  - 2. Raceway fittings.
  - 3. Conduit bodies.
  - 4. Pull and junction boxes.
  - 5. Handholes.
  - 6. Conduit, or raceway
- B. Manufacturer's Installation Instructions: Submit application conditions and limitations of use stipulated by Product testing agency specified under Regulatory Requirements. Include instructions for storage, handling, protection, examination, preparation, and installation of Product.

#### 1.7 CLOSEOUT SUBMITTALS

- A. Project Record Documents:
  - 1. Record actual routing of conduits larger than 1 inch.
  - 2. Record actual locations and mounting heights of outlet, pull, and junction boxes.

#### 1.8 DELIVERY, STORAGE, AND HANDLING

- A. Protect conduit from corrosion and entrance of debris by storing above grade. Provide appropriate covering.



- B. Protect PVC conduit from sunlight.

## 1.9 COORDINATION

- A. Coordinate installation of outlet boxes for equipment connected under Section 26 05 00.
- B. Coordinate mounting heights, orientation and locations of outlets.

## PART 2 PRODUCTS

### 2.1 METAL CONDUIT

- A. Manufacturers:
  - 1. Carlon Electrical Products
  - 2. Hubbell Wiring Devices
  - 3. Thomas & Betts Corp.
  - 4. Appleton
  - 5. Or approved equal.
- B. Rigid Steel Conduit: ANSI C80.1.
- C. Rigid Aluminum Conduit: ANSI C80.5.
- D. Intermediate Metal Conduit (IMC): Rigid steel.
- E. Fittings and Conduit Bodies: NEMA FB 1; material to match conduit. Furnish aluminum fittings with steel conduit. All steel fittings.

### 2.2 PVC COATED METAL CONDUIT

- A. Manufacturers:
  - 1. Carlon Electrical Products
  - 2. Hubbell Wiring Devices
  - 3. Rob Roy
  - 4. Or approved equal
- B. Product Description: NEMA RN 1; rigid steel conduit with external PVC coating, 40 mil thick.
- C. Fittings and Conduit Bodies: NEMA FB 1; steel fittings with external PVC coating to match conduit.

### 2.3 LIQUIDTIGHT FLEXIBLE METAL CONDUIT

- A. Manufacturers:
  - 1. Carlon Electrical Products
  - 2. Hubbell Wiring Devices
  - 3. Thomas & Betts Corp.
  - 4. Appleton

5. Crouse-Hinds
6. Or approved equal.

B. Product Description: Interlocked steel construction with PVC jacket.

C. Fittings: NEMA FB 1.

#### 2.4 ELECTRICAL METALLIC TUBING (EMT)

A. Manufacturers:

1. Appleton
2. Allied
3. Or approved equal

B. Product Description: ANSI C80.3; galvanized tubing.

C. Fittings and Conduit Bodies: NEMA FB 1; steel or malleable iron, compression set screw indenter type.

#### 2.5 NONMETALLIC CONDUIT

A. Manufacturers:

1. Carlon Electrical Products Model.
2. Or approved equal

B. Product Description: NEMA TC 2; Schedule 40 80 PVC.

C. Fittings and Conduit Bodies: NEMA TC 3.

#### 2.6 OUTLET BOXES

A. Manufacturers:

1. Carlon Electrical Products
2. Hubbell Wiring Devices
3. Thomas & Betts Corp.
4. Crouse-Hinds

B. Sheet Metal Outlet Boxes: NEMA OS 1, galvanized steel.

1. Luminaire and Equipment Supporting Boxes: Rated for weight of equipment supported; furnish 1/2 inch male fixture studs where required.
2. Concrete Ceiling Boxes: Concrete type.

C. Nonmetallic Outlet Boxes: NEMA OS 2.

D. Cast Boxes: NEMA FB 1, Type FD, aluminum cast fer alloy. Furnish gasketed cover by box manufacturer. Furnish threaded hubs.

E. Wall Plates for Finished Areas: As specified in Section 26 27 26.

F. Wall Plates for Unfinished Areas: Furnish gasketed cover.

## 2.7 PULL AND JUNCTION BOXES

- A. Manufacturers:
  - 1. Appleton
  - 2. Hubbell Wiring Devices Model.
  - 3. Triangle
  - 4. Allied
  - 5. Circle AW
  - 6. Or approved equal.
- B. Sheet Metal Boxes: NEMA OS 1, galvanized steel.
- C. Hinged Enclosures: As specified in Section 26 27 16.
- D. Surface Mounted Cast Metal Box: NEMA 250, Type 4 4X 6; flat-flanged, surface mounted junction box:
  - 1. Material: Galvanized cast iron.
  - 2. Cover: Furnish with ground flange, neoprene gasket, and stainless steel cover screws.
- E. In-Ground Cast Metal Box: NEMA 250, Type 6, outside flanged, recessed cover box for flush mounting:
  - 1. Material: Galvanized cast iron.
  - 2. Cover: Nonskid cover with neoprene gasket and stainless steel cover screws.
  - 3. Cover Legend: "ELECTRIC".
- F. Fiberglass Concrete composite Handholes: Die-molded, glass-fiber concrete composite hand holes:
  - 1. Cable Entrance: Pre-cut 6 inch x 6 inch cable entrance at center bottom of each side.
  - 2. Cover: Glass-fiber concrete composite, weatherproof cover with nonskid finish.

## PART 3 EXECUTION

### 3.1 EXAMINATION

- A. Verify outlet locations and routing and termination locations of raceway prior to rough-in.

### 3.2 EXISTING WORK

- A. Remove exposed abandoned raceway, including abandoned raceway above accessible ceiling finishes. Cut raceway flush with walls and floors, and patch surfaces. Section 02 41 26 – Selective Electrical Demolition.
- B. Disconnect abandoned outlets and remove devices. Remove abandoned outlets when raceway is abandoned and removed. Install blank cover for abandoned outlets not removed.

- C. Maintain access to existing boxes and other installations remaining active and requiring access. Modify installation or provide access panel.
- D. Extend existing raceway and box installations using materials and methods compatible with existing electrical installations, or as specified.
- E. Clean and repair existing raceway and boxes to remain or to be reinstalled.

### 3.3 INSTALLATION

- A. Fasten raceway and box supports to structure and finishes in accordance with Section 26 05 29.
- B. Identify raceway and boxes in accordance with Section 26 05 53.
- C. Arrange raceway and boxes to maintain headroom and present neat appearance.

### 3.4 INSTALLATION - RACEWAY

- A. Raceway routing is shown in approximate locations unless dimensioned. Route to complete wiring system.
- B. Arrange raceway supports to prevent misalignment during wiring installation.
- C. Support raceway using coated steel or malleable iron straps, lay-in adjustable hangers, clevis hangers, and split hangers.
- D. Group related raceway; support using conduit rack. Construct rack using steel channel specified in Section 26 05 29; provide space on each for 25 percent additional raceways.
- E. Do not support raceway with wire or perforated pipe straps. Remove wire used for temporary supports
- F. Do not attach raceway to ceiling support wires or other piping systems.
- G. Construct wireway supports from steel channel specified in Section 26 05 29.
- H. Route exposed raceway parallel and perpendicular to walls.
- I. Route raceway installed above accessible ceilings parallel and perpendicular to walls.
- J. Route conduit in and under slab from point-to-point.
- K. Maximum Size Conduit in Slab Above Grade: 1 inch. Do not cross conduits in slab.
- L. Maintain clearance between raceway and piping for maintenance purposes.
- M. Maintain 12 inch clearance between raceway and surfaces with temperatures exceeding 104 degrees F.

- N. Cut conduit square using saw or pipe cutter; de-burr cut ends.
- O. Bring conduit to shoulder of fittings; fasten securely.
- P. Join nonmetallic conduit using cement as recommended by manufacturer. Wipe nonmetallic conduit dry and clean before joining. Apply full even coat of cement to entire area inserted in fitting. Allow joint to cure for minimum 20 minutes.
- Q. Install conduit hubs or sealing locknuts to fasten conduit to sheet metal boxes in damp and wet locations and to cast boxes.
- R. Install no more than equivalent of three 90 degree bends between boxes. Install conduit bodies to make sharp changes in direction, as around beams. Install hydraulic one-shot bender to fabricate factory elbows for bends in metal conduit larger than 2 inch size.
- S. Avoid moisture traps; install junction box with drain fitting at low points in conduit system.
- T. Install fittings to accommodate expansion and deflection where raceway crosses seismic, control and expansion joints.
- U. Install suitable pull string or cord in each empty raceway except sleeves and nipples.
- V. Install suitable caps to protect installed conduit against entrance of dirt and moisture.
- W. Surface Raceway: Install flat-head screws, clips, and straps to fasten raceway channel to surfaces; mount plumb and level. Install insulating bushings and inserts at connections to outlets and corner fittings.
- X. Close ends and unused openings in wireway.

### 3.5 INSTALLATION - BOXES

- A. Install wall mounted boxes at elevations to accommodate mounting heights as indicated on Drawings.
- B. Adjust box location up to 10 feet prior to rough-in to accommodate intended purpose.
- C. Orient boxes to accommodate wiring devices oriented as specified in Section 26 27 26.
- D. Install adjustable steel channel fasteners for hung ceiling outlet box.
- E. Do not fasten boxes to ceiling support wires or other piping systems.
- F. Support boxes independently of conduit.
- G. Install gang box where more than one device is mounted together. Do not use sectional box.

3.6 INTERFACE WITH OTHER PRODUCTS

- A. Locate outlet boxes to allow luminaires positioned as indicated on Drawings.
- B. Align adjacent wall mounted outlet boxes for switches, thermostats, and similar devices.

3.7 ADJUSTING

- A. Adjust flush-mounting outlets to make front flush with finished wall material.
- B. Install knockout closures in unused openings in boxes.

3.8 CLEANING

- A. Clean interior of boxes to remove dust, debris, and other material.
- B. Clean exposed surfaces and restore finish.

END OF SECTION

SECTION 26 05 53

IDENTIFICATION FOR ELECTRICAL SYSTEMS

PART 1 GENERAL

1.1 SUMMARY

- A. Section Includes:
  - 1. Labels.
  - 2. Wire markers.
  - 3. Conduit markers.
  - 4. Stencils.

1.2 SUBMITTALS

- A. Section 01300 – Submittals.
- B. Product Data:
  - 1. Submit manufacturer's catalog literature for each product required.
  - 2. Submit electrical identification schedule including list of wording, symbols, letter size, color coding, tag number, location, and function.
- C. Samples:
  - 1. Submit two samples of each type of identification products applicable to project.
  - 2. Submit two nameplates, 4 x 4 inch in size illustrating materials and engraving quality.
- D. Manufacturer's Installation Instructions:
  - 1. Indicate installation instructions, special procedures, and installation.

1.3 QUALIFICATIONS

- A. Manufacturer: Company specializing in manufacturing Products specified in this section with minimum three years documented experience.
- B. Installer: Company specializing in performing Work of this section with minimum three years experience approved by manufacturer.

1.4 DELIVERY, STORAGE, AND HANDLING

- A. Accept identification products on site in original containers. Inspect for damage.
- B. Accept materials on site in original factory packaging, labeled with manufacturer's identification, including product density and thickness.
- C. Protect insulation from weather and construction traffic, dirt, water, chemical, and mechanical damage, by storing in original wrapping.

## PART 2 PRODUCTS

### 2.1 NAMEPLATES

- A. Material Manufacturers:
  - 1. Gravoply
  - 2. Lamicoid
  - 3. Or approved equal
- B. Product Description: Laminated three-layer plastic with engraved black letters on white contrasting background color.
- C. Letter Size:
  - 1. See label detail at end of section.
- D. Minimum nameplate thickness: 1/16 inch.

### 2.2 LABELS

- A. Manufacturers:
  - 1. Brother, Model “P-Touch”
  - 2. Panduit, Model PVL.
  - 3. HellermanTyton, Model Tag PP1.
  - 4. Or approved equal

### 2.3 WIRE MARKERS

- A. Manufacturers:
  - 1. Panduit, Model PDT43MY
  - 2. Brady, Model M21
  - 3. Tyton-Hellerman, Model Shrinktrak
  - 4. Raychem (Tyco), Model TMS -90
  - 5. Or approved equal.
- B. Description: self-laminating, heat shrinkable, or sleeve type wire markers.

## PART 3 EXECUTION

### 3.1 PREPARATION

- A. Degrease and clean surfaces to receive adhesive for identification materials.
- B. Prepare surfaces in accordance with Section 09 90 00- Painting and Coating for stencil painting.

### 3.2 EXISTING WORK

- A. Install identification on existing equipment to remain in accordance with this section.



### 3.3 INSTALLATION

- A. Install identifying devices after completion of painting.
- B. Wire Marker Installation:
  - 1. Install wire marker for each conductor at panelboards, pull boxes, outlet and junction boxes, and each load connection.
  - 2. Mark data cabling at each end. Install additional marking at accessible locations along the cable run.
  - 3. Install labels at data outlets identifying patch panel and port designation as indicated on Drawings.
  - 4. Legend:
    - a. Power and Lighting Circuits: Branch circuit or feeder number.
    - b. Control Circuits: Control wire number as indicated on schematic, interconnection diagrams, and drawings.
    - c. Use the following wire numbering convention for wires to process motors, process loads, and for instrumentation and controls: Source-Destination-Number.
      - 1) Example A: For a Power conductor from LCP-1 to Pump motor PU-18010 should read as follows: LCP1-PU18010-1.
      - 2) Example B: For a Instrumentation conductor from Control Panel LCP-1 to Pressure Switch PSH-04501B should read as follows: LCP1-PSH04051B-1.
      - 3) Multi-conductor cables (e.g., instrumentation and controls) shall be identified on the jacket by: Source-Destination. Example: LCP1-PSH04051B.
    - d. Use the wire numbering shown on the drawing for conductors in the interior of control panels.

END OF SECTION

Appendix: Panel Label Detail

SECTION 26 27 26

WIRING DEVICES

PART 1 GENERAL

1.1 SUMMARY

- A. Section includes wall switches; wall dimmers; receptacles; multi-outlet assembly; and device plates and decorative box covers.
- B. Related Sections:
  - 1. Section 26 05 33 - Raceway and Boxes for Electrical Systems: Outlet boxes for wiring devices.

1.2 REFERENCES

- A. National Electrical Manufacturers Association:
  - 1. NEMA WD 1 - General Requirements for Wiring Devices.
  - 2. NEMA WD 6 - Wiring Devices-Dimensional Requirements.

1.3 SUBMITTALS

- A. Section 01300 – Submittals.
- B. Product Data: Submit manufacturer's catalog information showing dimensions, colors, and configurations.
- C. Samples: Submit two samples of each wiring device and wall plate illustrating materials, construction, color, and finish.

1.4 QUALIFICATIONS

- A. Manufacturer: Company specializing in manufacturing products specified in this section with minimum three years documented experience.

1.5 EXTRA MATERIALS

- A. Section 01780 – Contract Closeout.
- B. Furnish two of each style, size, and finish wall plate.

PART 2 PRODUCTS

2.1 WALL SWITCHES

- A. Manufacturers:
  - 1. Arrow Hart Wiring Devices

2. Eagle Electric
3. Siemens Co.
4. Hubbell
5. Or approved equal.
6. Substitutions: Section 01630 – Product Requirements and Substitutions.

2.2 WALL SWITCHES

- A. Manufacturers:
1. Arrow Hart Wiring Devices
  2. Eagle Electric
  3. Leviton
  4. Hubbell
  5. Or approved equal.
  6. Substitutions: Section 01630 – Product Requirements and Substitutions.
- B. Product Description: NEMA WD 1, Heavy-Duty General-Duty, AC only general-use snap switch.
- C. Body and Handle: Brown plastic with toggle handle.
- D. Ratings:
1. Voltage: 120 120-277 volts, AC.
  2. Current: 20 15 30 amperes.
- E. See tables below.
- A. Toggle Switch:

<b>WIRING DEVICE CROSS REFERENCE - SWITCHES &amp; RECEPTACLES</b>				
	LEVITON	HUBBELL	ARROW-HART	EAGLE
<b>SWITCHES</b> - Not all switches types shown used in this work				
<b>TOGGLE: 20A</b> ; industrial specification grade; back and side wired; brown; general duty; 120V-277V. Color suffixes (I = Ivory, W = White, GY = Grey, R = Red, Black = E) not shown, but may be required as noted.				
Single Pole	1221-2	HBL 1221	1991	1238B
Double Pole	1222-2	HBL 1222	1992	1245B
Three Way	1223-2	HBL 1223	1993	1239B
Four Way	1224-2	HBL 1224	1994	1242B
<b>LOCKING: 20A</b> ; specification grade; back and side wired; brown; general duty; 120V-277V				
Single Pole	1221-2L	HBL 1221L	1991L	2221L
Double Pole	1222-2L	HBL 1222L	1992L	2222L

<b>WIRING DEVICE CROSS REFERENCE - SWITCHES &amp; RECEPTACLES</b>				
	LEVITON	HUBBELL	ARROW-HART	EAGLE
Three Way	1223-2L	HBL 1223L	1993L	2223L
Four Way	1224-2L	HBL 1224L	1994L	2224L
<b>PILOT LIGHTED: 20A</b> ; specification grade; back and side wired; brown; general duty; 120V-277V				
Single Pole	1221-PLC	HBL	1991PLC	2221PL
Double Pole	1222-PLC	..	1992PLC	2222PL
Three Way	1223-PLC	HBL	1993PLC	2223PL
Four Way	..	..	1994PLC	2224PL
<b>ILLUMINATED HANDLE: 20 AMP</b> ; specification grade; back and side wired; brown; general duty; 120V-277V				
Single Pole	1221-LHC	HBL	1991PLC	2221TLV
Double Pole	1222-LHC	..	1992PLC	2222TLV
Three Way	1223-LHC	HBL	1993PLC	2223TLV
Four Way	..	..	1994PLC	..
<b>MOMENTARY: 20 AMP</b> ; 2-circuit, 3-position, (center 'OFF'); specification grade; back and side wired; brown; general duty; 120V-277V				
SPDT	1257	HBL 1556	1995	2225B
<b>MAINTAINED: 20 AMP</b> ; 2-circuit, 3-position, (center 'OFF'); specification grade; back and side wired; brown; general duty; 120V-277V				
SPDT	1285		..	2226B

### 2.3 RECEPTACLES

- A. Manufacturers:
  - 1. See table.
  - 2. Substitutions: Section 01630 – Product Requirements and Substitutions.
- B. Product Description: NEMA WD 1, Heavy-duty general use receptacle.
- C. Device Body: Brown plastic.
- D. Configuration: NEMA WD 6, type.
- E. Convenience Receptacle: Type 5-20.
- F. GFCI Receptacle: Convenience receptacle with integral ground fault circuit interrupter to meet regulatory requirements.

2.4 WALL PLATES

- A. Manufacturers:
  1. Arrow Hart Wiring Devices
  2. Eagle Electric
  3. Or approved equal.
  4. Substitutions: Section 01 60 00 - Product Requirements.
- B. Decorative Cover Plate: brown, plastic. Smooth 302 stainless steel.
- C. Cover Plate: Ivory, smooth lined plastic nylon.
- D. Weatherproof Cover Plate: Gasketed cast metal plate with hinged and gasketed device cover.
- E. Galvanized Steel Cover Plate

<b>WIRING DEVICE CROSS REFERENCE - SWITCHES &amp; RECEPTACLES</b>				
	LEVITON	HUBBELL	ARROW-HART	EAGLE
<b>RECEPTACLES / PLUGS B</b> Not all receptacles or plug types shown are used in this work				
<b>STRAIGHT BLADE: 15A:</b> 2-Pole, 3-Wire Grounding; heavy duty, specification grade; back and side wired; brown; general duty; 125V; nylon-face; NEMA 5-15. Color suffixes (I = Ivory, W = White, GY = Grey, R = Red, Black = E) not shown, but may be required as noted.				
Duplex	5262	5262	5262	5262B
Single	5261	5261	5261	5261B
Isolated Ground	5262-IGI	IG5262	IG5262	IG5262V
Corrosion Resistant	..	52CM62	5262CR	..
Surge Suppression	8280I	5262S	5262S	..
Hospital Grade	8200	8200I	8200	8200B
Hospital/Tamper	5262-SG	HBLSG62	..	..
GFCI	6898	GF5262	GF5242	..
<b>STRAIGHT BLADE: 20A:</b> 2-Pole, 3-Wire Grounding; heavy duty, specification grade; back and side wired; brown; general duty; 125V; nylon-face; NEMA 5-20.				
Duplex	5362	5362	5362	5362B
Single	5361	5361	5361	5361B
Isolated Ground	5362-IGI	IG5362	IG5362	IG5362V
Corrosion Resistant	..	53CM62	5362CR	..
Surge Suppression	8380I	5362S	5362S	..

<b>WIRING DEVICE CROSS REFERENCE - SWITCHES &amp; RECEPTACLES</b>				
	LEVITON	HUBBELL	ARROW-HART	EAGLE
Hospital Grade	8300	8300I	8300	8300B
Hospital/Tamper	5362-SG	HBLSG62	..	..
GFCI	6899	GF5362	GF5342	..
<b>TWIST LOCK: 20A:</b> 2-Pole, 3-Wire Grounding; heavy duty, specification grade; back and side wired; black; general duty; single; nylon-face.				
125V, NEMA L5-20R	2310	2310A	6200	L520R
250V, NEMA L6-20R	2320	2320A	6210	L620R
277V, NEMA L7-20R	3720	2330A	6220	..
<b>TWIST LOCK: 20A:</b> 2-Pole, 3-Wire Grounding; heavy duty, specification grade; back and side wired; black; general duty; single; flanged mounting; nylon-face.				
125V, NEMA L5-20R	2316	2616	6206	..
250V, NEMA L6-20R	2326	2626	6216	..
277V, NEMA L7-20R	3756	2636	6226	

2.5 Welding Receptacle:

- A. Heavy Duty; weather-proof construction; metallic receptacle housing, high impact copper-free aluminum; cast aluminum back boxes; spring door cover, with matching plug.

<b>WIRING DEVICE CROSS REFERENCE - SWITCHES &amp; RECEPTACLES</b>				
	MENNEKES	HUBBELL	ARROW-HART	LEVITON
<b>PIN-AND-SLEEVE:</b> 4-Pole, 5-Wire Grounding; 480V/277V; heavy duty; box terminal wired; watertight, IP67.				
60A PLUG	..	460P7W	AH460P7W	..
<b>PIN-AND-SLEEVE, NON-FUSED DISCONNECT:</b> 3-Pole, 4-Wire Grounding; 480V/277V; heavy duty; box terminal wired; watertight, IP67.				
60A RCPT	..	460MI7W	AH460MI7W	..

## PART 3 EXECUTION

### 3.1 EXAMINATION

- A. Section 01040 – Project Coordination.
- B. Verify outlet boxes are installed at proper height.
- C. Verify wall openings are neatly cut and completely covered by wall plates.
- D. Verify branch circuit wiring installation is completed, tested, and ready for connection to wiring devices.

### 3.2 PREPARATION

- A. Clean debris from outlet boxes.

### 3.3 EXISTING WORK

- A. Disconnect and remove abandoned wiring devices.
- B. Modify installation to maintain access to existing wiring devices to remain active.
- C. Clean and repair existing wiring devices to remain or to be reinstalled.

### 3.4 INSTALLATION

- A. Install devices plumb and level.
- B. Install switches with OFF position down.
- C. Install wall dimmers to achieve full rating specified and indicated after derating for ganging as instructed by manufacturer.
- D. Do not share neutral conductor on load side of dimmers.
- E. Install receptacles with grounding pole on bottom.
- F. Connect wiring device grounding terminal to outlet box with bonding jumper and branch circuit equipment grounding conductor.
- G. Install decorative plates on switch, receptacle, and blank outlets in finished areas.
- H. Connect wiring devices by wrapping solid conductor around screw terminal. Install stranded conductor for branch circuits 10 AWG and smaller. When stranded conductors are used in lieu of solid, use crimp on fork terminals for device terminations. Do not place bare stranded conductors directly under device screws.
- I. Install galvanized steel plates on outlet boxes and junction boxes in unfinished areas, above accessible ceilings, and on surface mounted outlets.

### 3.5 INTERFACE WITH OTHER PRODUCTS

- A. Coordinate locations of outlet boxes provided under Section 26 05 33 to obtain mounting heights as specified and as indicated on drawings.
- B. Install wall switch 48 inches above finished floor, or as noted on drawings.
- C. Install convenience receptacle 18 inches above finished floor, or as indicated on drawings.

### 3.6 FIELD QUALITY CONTROL

- A. Section 01400 - Quality Requirements; Section 01780 – Contract Closeout.
- B. Inspect each wiring device for defects.
- C. Operate each wall switch with circuit energized and verify proper operation.
- D. Verify each receptacle device is energized.
- E. Test each receptacle device for proper polarity.
- F. Test each GFCI receptacle device for proper operation.

### 3.7 ADJUSTING

- A. Section 01780 – Contract Closeout.
- B. Adjust devices and wall plates to be flush and level.

### 3.8 CLEANING

- A. Section 01780 – Contract Closeout.
- B. Clean exposed surfaces to remove splatters and restore finish.

END OF SECTION



SECTION 26 28 19  
ENCLOSED SWITCHES

PART 1 GENERAL

1.1 SUMMARY

- A. Section includes fusible and nonfusible switches.

1.2 REFERENCES

- A. National Electrical Manufacturers Association:
1. NEMA FU 1 - Low Voltage Cartridge Fuses.
  2. NEMA KS 1 - Enclosed and Miscellaneous Distribution Equipment Switches (600 Volts Maximum).
- B. International Electrical Testing Association:
1. NETA ATS - Acceptance Testing Specifications for Electrical Power Distribution Equipment and Systems.

1.3 SUBMITTALS

- A. Product Data: Submit switch ratings and enclosure dimensions.

1.4 QUALIFICATIONS

- A. Manufacturer: Company specializing in manufacturing products specified in this section with minimum three years documented experience.

PART 2 PRODUCTS

2.1 FUSIBLE SWITCH ASSEMBLIES

- A. Manufacturers:
1. GE Electrical
  2. Hubbell Inc.
  3. Westinghouse Electric Corp.
  4. Square D
- B. Product Description: NEMA KS 1, Type HD, enclosed load interrupter knife switch. Handle lockable in OFF position.
- C. Fuse clips: Designed to accommodate NEMA FU 1, Class J fuses.

- D. Enclosure: NEMA KS 1, to meet conditions. Fabricate enclosure from steel finished with manufacturer's standard gray enamel.
  - 1. Interior Dry Locations: Type 12.
  - 2. Exterior Locations: Type 4.
- E. Service Entrance: Switches identified for use as service equipment are to be labeled for this application. Furnish solid neutral assembly and equipment ground bar.
- F. Furnish switches with entirely copper current carrying parts.

## 2.2 NONFUSIBLE SWITCH ASSEMBLIES

- A. Manufacturers:
  - 1. GE Electrical
  - 2. Hubbell Inc.
  - 3. Westinghouse Electric Corp.
  - 4. Square D
- B. Product Description: NEMA KS 1, Type HD enclosed load interrupter knife switch. Handle lockable in OFF position.
- C. Enclosure: NEMA KS 1, to meet conditions. Fabricate enclosure from steel finished with manufacturer's standard gray enamel.
  - 1. Interior Dry Locations: Type 1.
  - 2. Exterior Locations: Type 3R.
  - 3. Industrial Locations: Type 4.
- D. Service Entrance: Switches identified for use as service equipment are to be labeled for this application. Furnish solid neutral assembly and equipment ground bar.
- E. Furnish switches with entirely copper current carrying parts.

## 2.3 SWITCH RATINGS

- A. Switch Rating: Horsepower rated for AC or DC as indicated on Drawings.
- B. Short Circuit Current Rating: UL listed for 200,000 rms symmetrical amperes when used with or protected by Class R or Class J fuses (30-600 ampere switches employing appropriate fuse rejection schemes).

## PART 3 EXECUTION

### 3.1 INSTALLATION

- A. Install disconnect switches for motors and drivers as shown.
- B. Install enclosed switches plumb. Provide supports in accordance with Section 26 05 29.

- C. Height: 5 feet to operating handle maximum.
- D. Install fuses for fusible disconnect switches. Refer to Section 26 28 13 for product requirements.
- E. Install engraved plastic nameplates in accordance with Section 26 05 53.
- F. Apply adhesive tag on inside door of each fused switch indicating NEMA fuse class and size installed.

3.2 FIELD QUALITY CONTROL

- A. Inspect and test in accordance with NETA ATS, except Section 4.
- B. Perform inspections and tests listed in NETA ATS, Section 7.5.

END OF SECTION

SECTION 26 28 23

ENCLOSED CIRCUIT BREAKERS

PART 1 GENERAL

1.1 SUMMARY

- A. Section includes molded-case and insulated-case circuit breakers in individual enclosures.

1.2 REFERENCES

- A. National Electrical Manufacturers Association:
  - 1. NEMA AB 1 - Molded Case Circuit Breakers and Molded Case Switches.
- B. International Electrical Testing Association:
  - 1. NETA ATS - Acceptance Testing Specifications for Electrical Power Distribution Equipment and Systems.

1.3 SUBMITTALS

- A. Section 01300 – Submittals.
- B. Product Data: Submit catalog sheets showing ratings, trip units, time current curves, dimensions, and enclosure details.

1.4 CLOSEOUT SUBMITTALS

- A. Section 01780 – Contract Closeout.
- B. Project Record Documents: Record actual locations and continuous current ratings of enclosed circuit breakers.

1.5 QUALIFICATIONS

- A. Manufacturer: Company specializing in manufacturing products specified in this section with minimum three years documented experience.

1.6 EXTRA MATERIALS

- A. Section 01780 – Contract Closeout.
- B. Furnish three of each size and type of current limiter.

## PART 2 PRODUCTS

### 2.1 MOLDED CASE CIRCUIT BREAKER

- A. Manufacturers:
  - 1. Match existing panel manufacture for panel modifications.
  - 2. General Electric
  - 3. Square D
  - 4. Siemens
  - 5. Or approved equal.
- B. Product Description: Enclosed, molded-case circuit breaker conforming to NEMA AB 1, suitable for use as service entrance equipment where applied.
- C. Service Entrance: Switches identified for use as service equipment are to be labeled for this application. Furnish solid neutral assembly and equipment ground bar.

### 2.2 INSULATED CASE CIRCUIT BREAKER

- A. Manufacturers:
  - 1. Match existing panel manufacture for panel modifications.
  - 2. General Electric
  - 3. Square D
  - 4. Siemens
  - 5. Or approved equal.
- B. Product Description: Enclosed, insulated-case circuit breaker conforming to NEMA AB 1, suitable for use as service entrance equipment where applied.
- C. Service Conditions:
  - 1. Temperature: 70-85 degrees F.
  - 2. Altitude: 300 feet above sea level.
- D. Trip Unit: Electronic sensing, timing, and tripping circuits for adjustable current settings; ground fault trip with integral ground fault sensing; instantaneous trip; and adjustable short time trip.
- E. Accessories: As indicated on Drawings. Conform to NEMA AB 1.
  - 1. Handle Lock: Provisions for sealing, padlocking.
- F. Enclosure: NEMA AB 1, to meet conditions. Fabricate enclosure from steel finished with manufacturer's standard gray enamel.
  - 1. Interior Dry Locations: Type 1.
  - 2. Exterior Locations: Type 3R.
  - 3. Industrial Locations: Type 4X .
- G. Service Entrance: Switches identified for use as service equipment are to be labeled for this application. Furnish solid neutral assembly and equipment ground bar.

### PART 3 EXECUTION

#### 3.1 EXISTING WORK

- A. Disconnect and remove abandoned enclosed circuit breakers.
- B. Maintain access to existing enclosed circuit breakers and other installations remaining active and requiring access. Modify installation or provide access panel.
- C. Clean and repair existing enclosed circuit breakers to remain or to be reinstalled.

#### 3.2 INSTALLATION

- A. Install enclosed circuit breakers plumb. Provide supports in accordance with Section 26 05 29.
- B. Height: 5 feet to operating handle, or as shown on drawing.
- C. Locate and install engraved plastic nameplates in accordance with Section 26 05 53.

#### 3.3 FIELD QUALITY CONTROL

- A. Section 01400 - Quality Requirements; Section 01780 – Contract Closeout.
- B. Inspect and test in accordance with NETA ATS, except Section 4.
- C. Perform inspections and tests listed in NETA ATS, Section 7.6.1.1.

#### 3.4 ADJUSTING

- A. Section 01780 – Contract Closeout.
- B. Adjust trip settings to coordinate circuit breakers with other overcurrent protective devices in circuit.
- C. Adjust trip settings to provide adequate protection from overcurrent and fault currents.

END OF SECTION

## SECTION 26 29 23

### VARIABLE-FREQUENCY MOTOR CONTROLLERS

#### PART 1 GENERAL

##### 1.1 SUMMARY

- A. Section includes variable frequency controllers.
- B. Related Sections:
  - 1. Section 26 28 13 - Fuses.

##### 1.2 REFERENCES

- A. Institute of Electrical and Electronics Engineers:
  - 1. IEEE C62.41 - Recommended Practice on Surge Voltages in Low-Voltage AC Power Circuits.
- B. National Electrical Manufacturers Association:
  - 1. NEMA 250 - Enclosures for Electrical Equipment (1000 Volts Maximum).
  - 2. NEMA FU 1 - Low Voltage Cartridge Fuses.
  - 3. NEMA ICS 7 - Industrial Control and Systems: Adjustable Speed Drives.
  - 4. NEMA ICS 7.1 - Safety Standards for Construction and Guide for Selection, Installation, and Operation of Adjustable Speed Drive Systems.
- C. International Electrical Testing Association:
  - 1. NETA ATS - Acceptance Testing Specifications for Electrical Power Distribution Equipment and Systems.

##### 1.3 SUBMITTALS

- A. Section 01300 – Submittals.
- B. Shop Drawings: Indicate front and side views of enclosures with overall dimensions and weights shown; conduit entrance locations and requirements; and nameplate legends.
- C. Product Data: Submit catalog sheets showing voltage, controller size, ratings and size of switching and overcurrent protective devices, short circuit ratings, dimensions, and enclosure details.
- D. Test Reports: Indicate field test and inspection procedures and test results.
- E. Manufacturer's Field Reports: Indicate start-up inspection findings.

##### 1.4 CLOSEOUT SUBMITTALS

- A. Section 01780 – Contract Closeout.

- B. Operation and Maintenance Data: Submit instructions complying with NEMA ICS 7.1. Include procedures for starting and operating controllers, and describe operating limits possibly resulting in hazardous or unsafe conditions. Include routine preventive maintenance schedule.

#### 1.5 QUALIFICATIONS

- A. Manufacturer: Company specializing in manufacturing products specified in this section with minimum three years documented experience.

#### 1.6 DELIVERY, STORAGE, AND HANDLING

- A. Section 01630 – Product Requirements and Substitutions.
- B. Store in clean, dry space. Maintain factory wrapping or provide additional canvas or plastic cover to protect units from dirt, water, construction debris, and traffic.
- C. Handle in accordance with manufacturer's written instructions. Lift only with lugs provided. Handle carefully to avoid damage to components, enclosure, and finish.

#### 1.7 ENVIRONMENTAL REQUIREMENTS

- A. Section 01630 – Product Requirements.
- B. Conform to NEMA ICS 7 service conditions during and after installation of variable frequency controllers.

#### 1.8 WARRANTY

- A. Section 01780 – Contract Closeout.
- B. Furnish five year manufacturer warranty for variable frequency controller.

#### 1.9 MAINTENANCE SERVICE

- A. Section 01780 – Contract Closeout.
- B. Furnish service and maintenance of variable frequency controller for one year from Date of Substantial Completion.

#### 1.10 MAINTENANCE MATERIALS

- A. Section 01780 – Contract Closeout.
- B. Furnish two of each air filter.



## PART 2 PRODUCTS

### 2.1 VARIABLE FREQUENCY CONTROLLER

A. Manufacturers:

1. ABB (Asea-Brown-Boveri), Model ACH550
2. Substitutions: Not Permitted.

B. Product Description: NEMA ICS 7, enclosed variable frequency controller suitable for operating indicated loads. Select unspecified features and options in accordance with NEMA ICS 7.1.

C. Ratings:

1. Rated Input Voltage: 208 volts, three phase, 60 Hertz.
2. Motor Nameplate Voltage: 208 volts, three phase, 60 Hertz.
3. Displacement Power Factor: Between 1.0 and 0.95, lagging, over entire range of operating speed and load.
4. Operating Ambient: 0 degrees C to 40 degrees C.
5. Minimum Efficiency at Full Load: 90 percent.

D. Design Features:

1. Employ microprocessor-based inverter logic isolated from power circuits.
2. Employ pulse-width-modulated inverter system.
3. Design for ability to operate controller with motor disconnected from output.
4. Design to attempt five automatic restarts following fault condition before locking out and requiring manual restart.

E. Indicators and Manual Controls:

1. Input Signal: 4 - 20 mA DC, Siemens communication P1.
2. Display: Furnish integral digital display to indicate output voltage, output frequency, and output current.
3. Status Indicators: Separate indicators for overcurrent, overvoltage, ground fault, overtemperature, and input power ON.
4. Volts Per Hertz Adjustment: Plus or minus 10 percent.
5. Current Limit Adjustment: 60 - 110 percent of rated.
6. Acceleration Rate Adjustment: 0.5 - 30 seconds.
7. Deceleration Rate Adjustment: 1 - 30 seconds.
8. Control Power Source: Separate circuit.

F. Safeties and Interlocks:

1. Includes undervoltage release.
2. Door Interlocks: Mechanical means to prevent opening of equipment with power connected, or to disconnect power when door is opened; include means for defeating interlock by qualified persons.
3. Safety Interlocks: Terminals for remote contact to inhibit starting under both manual and automatic mode.
4. Control Interlocks: Furnish terminals for remote contact to allow starting in automatic mode.
5. Disconnecting Means: Integral fused disconnect switch with clips for NEMA FU 1, Class J suitable for solid state protection fuses on line side of each controller.

- G. Fabrication:
  - 1. Wiring Terminations: Match conductor materials and sizes as indicated on Drawings.
  - 2. Enclosure: NEMA 250, Type 1, suitable for equipment application in places restricted to persons employed on premises.
  - 3. Finish: Manufacturer's standard enamel.

## 2.2 SOURCE QUALITY CONTROL

- A. Shop inspect and perform standard productions tests for each controller.
- B. Make completed controllers available for inspection at manufacturer's factory prior to packaging for shipment. Notify Owner Architect/Engineer at least seven days before inspection is allowed.
- C. Allow witnessing of factory inspections and tests at manufacturer's test facility. Notify Owner Architect/Engineer at least seven days before inspections and tests are scheduled.

## PART 3 EXECUTION

### 3.1 EXAMINATION

- A. Section 01040 – Project Coordination.
- B. Verify building environment is maintained within service conditions required by manufacturer.

### 3.2 EXISTING WORK

- A. Disconnect and remove abandoned controllers.
- B. Clean and repair existing controllers to remain or to be reinstalled.

### 3.3 INSTALLATION

- A. Install in accordance with NEMA ICS 7.1.
- B. Tighten accessible connections and mechanical fasteners after placing controller.
- C. Install fuses in fusible switches.
- D. Select and install overload heater elements in motor controllers to match installed motor characteristics.
- E. Install engraved plastic nameplates in accordance with Section 26 05 53.
- F. Neatly type label inside controller door identifying motor served, nameplate horsepower, full load amperes, code letter, service factor, and voltage/phase rating. Place label in clear plastic holder.
- G. Ground and bond controller in accordance with Section 26 05 26.

3.4 FIELD QUALITY CONTROL

- A. Section 01400 - Quality Requirements; Section 01780 – Contract Closeout.
- B. Inspect and test in accordance with NETA ATS, except Section 4.
- C. Perform inspections and tests listed in NETA ATS, Section 7.16 and NEMA ICS 7.1.

3.5 MANUFACTURER'S FIELD SERVICES

- A. Section 01400 - Quality Requirements.
- B. Prepare and startup variable frequency controller.

3.6 DEMONSTRATION AND TRAINING

- A. Not Required.

END OF SECTION



EXISTING CHILLER SCHEDULE	
EQUIPMENT NUMBER	SB1-CH-01
STATUS	EXISTING
OPTION	
LOCATION	SCIENCE 1
REF. DWG	
SYSTEM SERVED	CHILLED WATER
UNIT CONFIGURATION	
NOMINAL CAPACITY (TONS)	400
CHILLER TYPE	CENTRIFUGAL
REFRIGERANT/CHARGE	R-134a
NUMBER OF STAGES	1
PART LOAD (KW/Ton @ AR)	
FULL LOAD (KW/Ton @ AR)	0.801
CHILLED WATER	
DISCHARGE SIZE (IN)	8
MAIN SIZE (IN)	
WATER FLOW MIN. (GPM)	
WATER FLOW DESIGN (GPM)	773
PRESSURE DROP (PSI)	4.7
ENLET WATER TEMP (F)	54
L.V.G. WATER TEMP (F)	42
CONDENSER WATER	
DISCHARGE SIZE (IN)	
MAIN SIZE (IN)	
WATER FLOW MIN. (GPM)	
WATER FLOW DESIGN (GPM)	1012
PRESSURE DROP (PSI)	9.6
ENLET WATER TEMP (F)	80.0
L.V.G. WATER TEMP (F)	95.0
COMPRESSOR MOTOR	
ENCLOSURE TYPE	
SPEED CONTROL (VFD)	N
ELECTRICAL	
VOLTS / PHASE / HERTZ	208/3/60
MCA/MOCP	
STANDARD OF ACCEPTANCE	
MANUFACTURER	MCQUAY
MODEL	PEM-087
SERIAL NUMBER	9582435010
OPERATING WEIGHT (LBS)	
REMARKS	5
REMARKS	1 CHILLER PREPURCHASE BY OWNER 2 DISASSEMBLY, RIGGING AND REASSEMBLY ON SITE INCLUDED. (OFM) 3 REMOVABLE NOISE REDUCTION COVER ON COMPRESSOR, CONDENSOR TUBE AND PIPES INCLUDED. (OFD) 4 DOUBLE NEOPRENE EQUIPMENT SUPPORT PADS INCLUDED. (OFD) 5 FLOW, HEAD AND TEMPERATURE DATA TAKEN FROM 1964 RECORD DRAWINGS.

NEW COOLING TOWERS		
EQUIPMENT NUMBER	SB1-CT-01	
STATUS	NEW	
LOCATION	SCIENCE BUILDING 1 ROOF	
REF. DWG		
SYSTEM SERVED	CH-01	
FLUID	CONDENSER WATER	
NORMAL CAPACITY (TONS)		
UNIT CONFIGURATION		
TYPE	INDUCED DRAFT	
ASHRAE PERFORMANCE (GPM/HP)		
LINE CONNECTION SIZE (IN)	6"	
SUMP VOLUME (GAL)		
OPERATING WEIGHT (LBS)	11,460	
SPEED CONTROL	VFD	
SERVICE CONDITIONS - FLUID SIDE		
FLUID	WATER	
FLOW (GPM)	1012	
EWT (F)	94.3	
LWT (F)	80	
STATIC LIFT (FT-WC)		
SUMP SWEEPER INLET PRESSURE (PSI)		
AMBIENT WBT (F)	69	
EVAPORATION FLOW (GPM)	11.6	
BLOW-DOWN FLOW (GPM)		
MAKE-UP FLOW (GPM)		
SERVICE CONDITIONS - AIR SIDE		
FAN QUANTITY	1	
FAN TYPE	AXIAL	
FLOW (CFM)		
MOTOR ENCLOSURE TYPE		
SPEED (RPM)		
SHAFT POWER (BHP)		
POWER (HP)	30	
VOLTS / PHASE / HERTZ	208/3/60	
SUMP HEATER		
ELECT IMMERSION (KW)	NONE	
VOLTS / PHASE / HERTZ		
CONTROLS		
POWER (KW)		
VOLTS / PHASE / HERTZ	24/1/	
STANDARD OF ACCEPTANCE		
MANUFACTURER	EVAPCO	
MODEL	AT-19-912CT	
DESIGN OP WEIGHT (LBS)	14,700	
ACCESSORIES		
DAINT	GRADE	X
LADDER		X
DRIFT ELIMINATORS		X
VIBRATION SENSORS		X
SEISMIC BASE WITH ISOLATORS		X
STAINLESS STEEL BASIN		
REMARKS	1 SUMP SWEEPER 2 (2) 3" CONNECTIONS FOR SIDESTREAM FILTER 3 4	

EXISTING CONDENSER WATER PUMP SCHEDULE		
EQUIPMENT NUMBER	SB1-P-01	SB1-P-02
STATUS	EXISTING	EXISTING
OPTION		
LOCATION	SB1	SB1
REF. DWG		
SERVICE		SB1-CT-01 TO SB1-CH-01
FLUID	CWS/R	CDS/R
	CHILLED WATER	CONDENSER WATER
PUMP		
PUMPING TYPE		SPLIT CASE
SPEED CONTROL (VFD)		N
FLOW (GPM)	1160	770
HEAD (FT)		82
ELECTRICAL		
VOLTS / PHASE / HERTZ		220 / 3 /
HP	25	25
RPM	1760	1760
AMPS		
STANDARD OF ACCEPTANCE		
MANUFACTURER		WORTHINGTON
MODEL		4DNE-84
WEIGHT (LBS)		
SERIAL NUMBER		
REMARKS	1 NEW MOTORS, SEE SPEC. 23 05 13. 2 PROVIDE FLEX CONNECTORS WITH FLOW VANE ON INLET AND OUTLET. 3 INERTIA BASE. SEE SPEC. 23 05 48 4 PROVIDE 4" CONNECTIONS ON FILTER 5 PROVIDE 6" CONCRETE PAD FOR PUMP 6 MOTOR SHALL BE ODP. PROVIDE WEATHER PROOF PROTECTION FOR PUMP AND RELATED ACCESSORIES.	

**SYMBOL LEGEND**

- ☐ - SOLENOID VALVE
- ☒ - CHECK VALVE
- ☒ - GATE VALVE
- ☒ - GATE VALVE (NORMALLY CLOSED)
- ☒ - GLOBE VALVE
- ☒ - BUTTERFLY VALVE
- ☒ - 3 WAY VALVE
- ☒ - FLANGE
- ☒ - UNION
- ☒ - POINT OF CONNECTION
- ☒ - TURBINE METER
- ☒ - VORTEX METER
- ☒ - SUCTION DIFFUSER
- ☒ - PETE'S PLUG
- ☒ - DOUBLE SPHERE FLEX CONNECTION

**ABBREVIATIONS**

- AFT - ABOVE FINISHED FLOOR
- HT - HEAT TRACE
- WP - WATER PROOF
- (D) - DEMO
- (E) - EXISTING
- (N) - NEW

**FLUID IDENTIFICATION**

- C - CONDENSER WATER SUPPLY
- CR - CONDENSER WATER RETURN
- CW - CITY WATER
- CWS - CHILLED WATER SUPPLY
- CWR - CHILLED WATER RETURN
- DRN - DRAIN

**PIPE LINE LEGEND**

- - NEW PIPE
- - - - - EXIST PIPE TO BE LINED
- - - - - EXIST/FUTURE (LIGHT)
- X - X - HEAT TRACED & INSULATED

**MECHANICAL GENERAL NOTES:**

- THE FOLLOWING NOTES APPLY TO ALL MECHANICAL DRAWINGS. ADDITIONAL GENERAL NOTES AND KEYED NOTES ARE PROVIDED ON INDIVIDUAL DRAWINGS.
- THE CONTRACTOR SHALL BE RESPONSIBLE FOR THE COORDINATION OF THE PHASING AND INSTALLATION OF ALL MECHANICAL WORK WITH THE WORK OF ALL OTHER TRADES. THE CONTRACTOR SHALL BEAR THE TOTAL EXPENSE FOR ANY ADDITIONAL WORK WHICH MAY BE CAUSED BY THE IMPROPER SEQUENCING OF CONSTRUCTION ACTIVITIES.
- THE DRAWINGS, P&ID, PLAN VIEWS, AND SPECIFICATIONS ARE COMPLEMENTARY. WHAT IS CALLED FOR IN ONE SHALL BE CALLED FOR IN BOTH.
- CONTRACTOR SHALL INCLUDE ALL INCIDENTAL ITEMS AND WORK NOT SPECIFICALLY SHOWN OR SPECIFIED BUT REQUIRED BY GOOD PRACTICE IN A COMPLETE SYSTEM.
- THE DRAWINGS ARE DIAGRAMMATIC AND EQUIPMENT HOOK-UP IS BASED ON ONE MANUFACTURER'S EQUIPMENT. THEY SHOULD BE FOLLOWED AS CLOSELY AS POSSIBLE, YET ARE NOT INTENDED TO SHOW EVERY ITEM IN ITS EXACT LOCATION OR ALL THE DETAILS OF THE EQUIPMENT, WHERE REQUIRED BY JOB-SITE CONDITIONS, RELOCATE AND PROVIDE FITTINGS, SUPPORTS, ETC. AS REQUIRED. EXISTING EQUIPMENT AND PIPING SIZES, LOCATIONS AND DIMENSIONS SHALL BE VERIFIED IN THE FIELD PRIOR TO DEMOLITION AND CONSTRUCTION. NOTIFY THE ENGINEER IMMEDIATELY OF ALL DISCREPANCIES AFFECTING THE REMOVAL OF EXISTING EQUIPMENT AND PIPING AND THE INSTALLATION OF NEW EQUIPMENT AND PIPING. ANY DEVIATIONS FROM THE DRAWINGS SHALL BE INCLUDED IN SHOP DRAWINGS APPROVED BY THE OWNER'S REPRESENTATIVE.
- TO ENHANCE CLARITY OF DRAWINGS AND WHERE NOT NECESSARY TO DESCRIBE THE REQUIRED PIPE SIZES, INDIVIDUAL SEGMENTS OF PIPE BETWEEN CONNECTIONS ARE NOT NECESSARILY SIZED ON PLANS. PIPE SEGMENTS ARE SHOWN ON PLANS WITHOUT A SIZE INDICATED SHALL BE THE SAME SIZE AS THE NEXT UPSTREAM SEGMENT WITH A SIZE INDICATED.
- COORDINATE ALL MECHANICAL PENETRATIONS, EMBEDS, AND ASSOCIATED END CONNECTIONS WITH STRUCTURAL DRAWINGS. NO PENETRATIONS WILL BE ALLOWED THROUGH STRUCTURAL ELEMENTS UNLESS INDICATED ON STRUCTURAL DRAWINGS OR AS APPROVED BY THE STRUCTURAL ENGINEERS. DO NOT CORE DRILL OR DRILL THROUGH BEAMS, COLUMNS, FLOORS, CEILING, OR WALLS, UNLESS INDICATED ON STRUCTURAL DRAWINGS OR AS APPROVED BY THE STRUCTURAL ENGINEER. OBTAIN APPROVAL FROM STRUCTURAL ENGINEER FOR ALL MECHANICAL PENETRATIONS.
- COORDINATE LOCATIONS OF MECHANICAL EQUIPMENT AND PIPING TO PROVIDE ADEQUATE CLEARANCE FOR REMOVAL AND SERVICE ACCESS NECESSARY FOR ALL EQUIPMENT PREVENTATIVE MAINTENANCE AND REPAIR. COORDINATE SERVICE ACCESS FOR EQUIPMENT PROVIDED BY ALL OTHER TRADES, INCLUDING BUT NOT LIMITED TO ELECTRICAL EQUIPMENT, PLUMBING, FIRE PROTECTION, AND LIGHTING.
- PROVIDE SUPPORTS AND SEISMIC RESTRAINTS FOR ALL PIPES AND RELATED EQUIPMENT THAT ARE SPECIFIED AND SHOWN ON THE DRAWINGS. PROVIDE ALL REQUIRED SUPPLEMENTARY STRUCTURAL STEEL, SUPPORTS, ATTACHMENTS, AND ANCHORAGES. PROVIDE ANCHOR BOLTS OF SIZE, TYPE, AND LENGTH AS REQUIRED TO SATISFY THE EQUIPMENT MANUFACTURER'S RECOMMENDATIONS, SPECIFICATION REQUIREMENTS, AND REQUIREMENTS WHICH MAY BE INDICATED ON THE CONTRACT DRAWINGS. SEE STRUCTURAL DRAWINGS AND SPECS FOR ADDITIONAL REQUIREMENTS.
- PROVIDE PLUG, CAP OR BLIND FLANGES ON OPEN ENDS OF VALVES, PIPES AND FITTINGS.
- ALL PIPE SUPPORTS, PIPE SHOES, HANGERS, AND ASSOCIATED METAL WORK IN THE UTILITY AREA, OUTDOORS, UTILITY TUNNELS, AND WET AREAS SHALL BE ALL HOT DIP GALVANIZED OR STAINLESS STEEL.
- DURING CONSTRUCTION, BUILDING UTILITIES WILL REMAIN OPERATIONAL. CONTRACTOR SHALL BE RESPONSIBLE FOR PROVIDING TEMPORARY UTILITIES, CONNECTIONS TO EXISTING SERVICE UTILITIES AND COORDINATION OF SHUTDOWNS WITH THE OWNER.
- PROTECT ALL EXISTING EQUIPMENT THAT IS TO REMAIN. REPAIR AND/OR REPLACE ALL EXISTING UTILITIES, STRUCTURAL ELEMENTS, EQUIPMENT, PIPING, CONDUIT, DUCTWORK, ETC. THAT IS DAMAGED OR BECOMES INOPERABLE AS A RESULT OF THIS WORK.
- SEE GENERAL ARRANGEMENT PLANS FOR REMOVAL OF EXISTING COOLING TOWER AND PLACEMENT OF NEW COOLING TOWER AND SIDE STREAM FILTER (SUMP SWEEPER SYSTEM).
- SEE STRUCTURAL DRAWING FOR MOUNTING AND SUPPORT OF NEW COOLING TOWER.
- ELECTRICAL CONTRACTOR TO INSTALL POWER TO NEW COOLING TOWER FROM EXISTING POWER PANEL LOCATED IN MECHANICAL ROOM 519. SEE PARTIAL MECHANICAL ROOM 519 PLAN FOR LOCATION OF NEW ABB MOUNTED VFD AND LOCATION FOR POWER SUPPLY TO NEW SIDE STREAM FILTER. PROVIDE REQUIRED NEW BREAKERS OR FUSED DISCONNECTS REQUIRED TO MEET NEC CODE.
- PSU WILL COMMISSION AND PROGRAM THE SYSTEM. CONTRACTOR WILL PROVIDE ASSISTANCE NORMAL FOR COMMISSIONING.

UTILITY PIPING AND INSULATION SCHEDULE																							
SYSTEM ID	SERVICE	LOCATION	SIZE	DESIGN PRESS. (PSIG)	DESIGN TEMP. (F)	PIPE SPECIFICATIONS						FITTING SPECIFICATIONS				INSULATION TYPE		INSULATION THICKNESS (IN)		PRESSURE TEST PROCEDURE			
						MAT'L	ASTM STD.	GRADE / PROC. TYPE	WALL THK.	END PREP	FITTING	RATING, FACE, STD.	TYPE	GASKETS	BOLT / NUT MAT'L	UTILITY AREA	OUTSIDE / TUNNEL	INSSTALL. CODE	TYPE	MEDIUM	TEST PRES.	TEST TEMP (F)	DURATION
CWS CWR	CHILLED WATER - SUPPLY	ALL AREAS	2" and LESS	80	50	CS	A53	B	SCH. 40	THREADED	THREADED	150#, RF, A105	EPDM	ZINC PLATED	D	E	3/4	B31.9	H	WATER	120	AMB	4 HRS.
	CHILLED WATER - RETURN	ALL AREAS	2 1/2" to 14"	80	50	CS	A53	B	SCH. 40	GROOVED	GROOVED	150#, RF, A105	EPDM	ZINC PLATED	D	E	2	B31.9	H	WATER	120	AMB	4 HRS.
CDS CDR	CONDENSER WATER - SUPPLY	ALL AREAS	2" and LESS	80	50	CS	A53	B	SCH. 40	THREADED	THREADED	150#, RF, A105	EPDM	ZINC PLATED	NONE	NONE	NONE	B31.9	H	WATER	120	AMB	4 HRS.
	CONDENSER WATER - RETURN	ALL AREAS	2 1/2" to 14"	80	50	CS	A53	B	SCH. 40	GROOVED	GROOVED	150#, RF, A105	EPDM	ZINC PLATED	NONE	NONE	NONE	B31.9	H	WATER	120	AMB	4 HRS.

**NOTE:**

- \* = WHERE INDICATED
- \*\* = ABI (ADDITIVE BID ITEM)
- \*\*\* = NO PIPING INSULATION REQ'D
- \*\*\*\* = HEAT TRACE WHERE INDICATED

**ABBREVIATION:**

- BW - BUTT WELD
- P - PNEUMATIC
- CS - CARBON STEEL
- ERW - ELECTRIC RESIST. WELDED
- FF - FLAT FACE
- GALV - GALVANIZED STEEL
- GRV - GROOVED
- H - HYDRAULIC
- CU - COPPER

**OMSC - OREGON MECH SPECIALTY CODE**

- SS - STAINLESS STEEL
- SW - SOCKET WELD
- THD - THREADED
- WI - WHERE INDICATED
- WN - WELD NECK
- U/C - UNDERGROUND

**INSULATIONS:**

- A = GLASS FIBER / ALUMINUM JACKET (CAL-SIL INSERTS AT SUPPORTS)
- B = GLASS FIBER / ALUMINUM CLAD JACKET (CAL-SIL INSERTS AT SUPPORTS)
- C\* = GLASS FIBER / SS JACKET (CAL-SIL INSERTS AT SUPPORTS)
- D = CLOSED CELL / PVC JACKET (HIGH DENSITY CLOSED CELL AT SUPPORTS), (BLUE JACKET COLOR FOR CHILLED WATER)
- E = CLOSED CELL / ALUMINUM JACKET (HIGH DENSITY CLOSED CELL AT SUPPORTS) \*\*\*\*
- G = CLOSED CELL / PVC JACKET & HEAT TRACED (HIGH DENSITY CLOSED CELL AT SUPPORTS)
- H = INORGANIC GRANULAR INSULATION (GILSULATE 500w)

VALVE SPECIFICATION SCHEDULE																						
SYSTEM ID	SERVICE	VALVE ID	TYPE	SIZE	VALVE MAX. PRESS. (PSIG)	VALVE OP. TEMP. (F)	MATERIAL OF CONSTRUCTION					TYPE OF CONSTRUCTION					MANUFACTURER	MODEL NO.	ALTERNATE MANUFACTURER / MODEL NO.	ALTERNATE MANUFACTURER / MODEL NO.	ALTERNATE MANUFACTURER / MODEL NO.	COMMENTS
							BODY	TRIM	DISC	SEATS	PACKG.	BODY CLASS	CONNECTION	OPERATOR	MANUFACTURER	MODEL NO.						
CWS CWR	CHILLED WATER - SUPPLY	A/V	AIR VENT	3/4"	150	250	SS	SS	SS	SS	SS	THD	FLOAT	ARMSTRONG	11-AV					With Gooseneck drain tube		
	CHILLED WATER - RETURN	B2	BALL, 3-PC	1/4" - 3"	150 SAT	390	SS	SS	SS	RP/TFE	150#	THD	LEVER	APOLLO	82-140					SEE NOTE 17		
CDS CDR	CONDENSER WATER - SUPPLY	BV1	BALANCING VALVE	1/2" - 3"	300 WOG	250	BRONZE	SS	SS	PTFE	125#	THD	KNOB	B&G	CB (A-549 G)					SEE NOTE 17		
	CONDENSER WATER - RETURN	BV2	SETER	2 1/2" - 8"	175 WOG	250	CI	BRASS	BRONZE	EPDM	125#	FLG/GROOVED	KNOB	B&G	CB (A-547 F)					SEE NOTE 17		
CWS CWR	CHILLED WATER - SUPPLY	BV3	AUTO BAL. VALVE	4" - 12"	400	200	CS	SS	SS	SS	150#	FLG/GROOVED		GRISWOLD CONTROLS						Confirm flow rates for sizing		
	CHILLED WATER - RETURN	C1	SWING CHECK	1/2" - 3"	185	200	BRONZE	BRONZE	BRONZE	THD	150#	SWING	CRANE	37						SEE NOTE 17		
	CONDENSER WATER - SUPPLY	C2	SWING CHECK	2" - 12"	190	200	CI	BRONZE	BRONZE CMP	CI	125#	FLG	SWING	CRANE	373					SEE NOTE 17		
	CONDENSER WATER - RETURN	C5	SWING CHECK	2" - 10"	200	150	CI	SS	SS	BRONZE	125#	WAFER	SWING	HAMMOND	IR9253					SEE NOTE 17		
	CONDENSER WATER - SUPPLY	F1	BUTTERFLY	2" - 48"	250	200	CS	SS	SS	TFE	150#	LUG	LEVER	FLOWSEAL	ILA-1221TG-B	FNW	ABZ, ABZOLUTE SERIES 400			SEE NOTE 17		
	CONDENSER WATER - RETURN	F2	BUTTERFLY	2" - 12"	175	275	DI	SS	SS	DI / EPDM	DI	NRB O-RING	GROOVED	MUELLER STEAM	89-GEN					SEE NOTE 17		
	CONDENSER WATER - SUPPLY	F3	BUTTERFLY	2" - 24"	150	275	DI	SS	SS	EPDM	PTFE	150#	WAFER	LEVER	APOLLO	141				SEE NOTE 17		
	CONDENSER WATER - RETURN	S2	STRAINER	2" - 12"	150	560	CS	304SS	SS	EPDM	PTFE	150#	FLG	MUELLER	781	FNW - 731				SEE NOTE 17		
	CONDENSER WATER - SUPPLY	S3	STRAINER	2" - 12"	150	560	CS	304SS	SS	EPDM	PTFE	150#	GROOVED	MUELLER	781 WE	METRAFLEX TF				SEE NOTE 17		

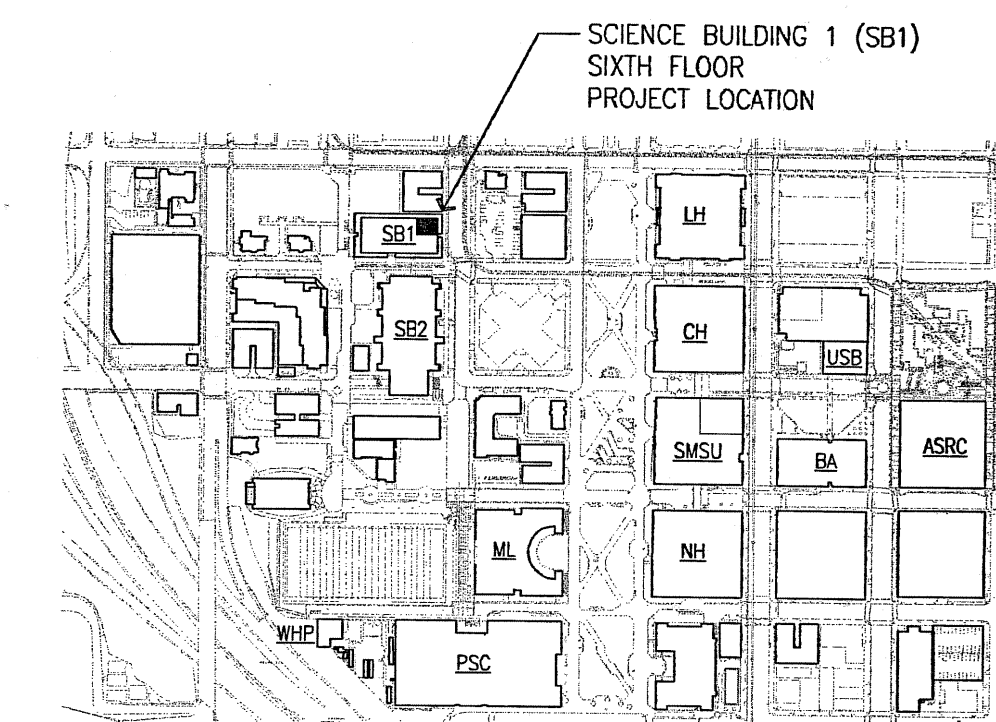

GHD INC.  
718 Third Street, Eureka, California 95501 USA  
T 1 707 443 8328 F 1 707 444 8330  
www.ghd.com

REUSE OF DOCUMENTS  
This document and the ideas and designs incorporated herein, as an instrument of professional service, is the property of GHD Inc. and shall not be reused in whole or in part for any other project without GHD Inc.'s written authorization. © GHD Inc. 2012

DATE	DESCRIPTION
02/15/12	ISSUED FOR BID & PERMIT
0	MARK

**M-1**

SHEET - OF



REUSE OF DOCUMENTS  
0  
ORIGINAL DRAWING  
BARS ONE INCH ON

ISSUE  
MARK  
DATE  
DESCRIPTION

0 02/15/12 ISSUED FOR BID & PERMIT

This document and the ideas and designs incorporated herein, as an instrument of professional service, is the property of GHD Inc. and shall not be reused in whole or in part for any other project without GHD Inc.'s written authorization. © GHD Inc. 2012

GHD Inc.  
718 Third Street  
Eureka, California 95501 USA  
T 1 707 443 8326  
F 1 707 444 8330  
www.ghd.com

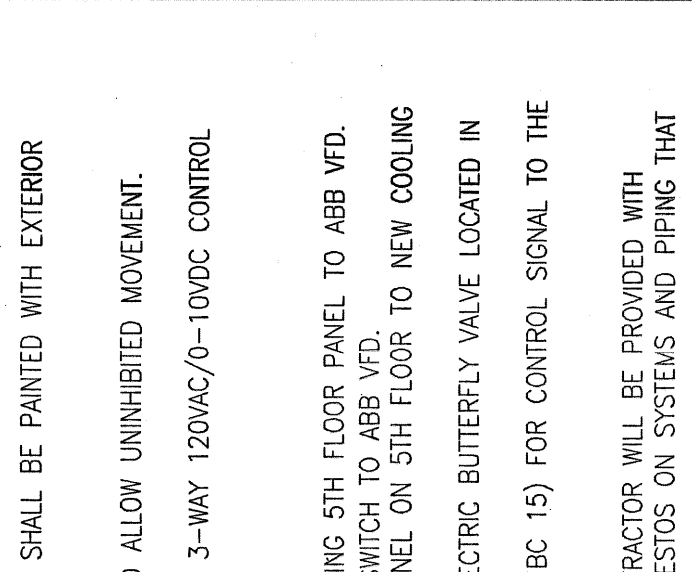

- KEYED NOTES:**
1. DRAIN EXISTING PORTION OF CONDENSER BEINS SYSTEM AND DEMOLISH EXISTING 6" CONDENSER (C05/C06) LINES SERVING EXISTING COOLING TOWER ABOVE SIXTH FLOOR ROOF.
  2. INSTALL NEW PIPING ABOVE ROOF TO NEW COOLING TOWER. ALL EXTERIOR PIPING SHALL BE PAINTED WITH EXTERIOR COATING. COLOR TO BE BLUE (MATCH EXISTING SYSTEM COLOR).
  3. PROVIDE FLEX CONNECTIONS ON ALL UTILITIES SERVING NEW COOLING TOWER TO ALLOW UNINHIBITED MOVEMENT.
  4. PROVIDE EXISTING 3-WAY VALVE AT PUMP SBI-P2 AND REPLACE WITH NEW BRAY 3-WAY 120VAC/0-100DC CONTROL VALVE WITH ELECTRONIC ACTUATOR, PART #294-08629.
  5. OWNER SPECIFIED CONTROL WIRING NOTES:  
A. PROVIDE RACEWAY AND 24/2 LO COP CABLE FOR COMMUNICATION FROM EXISTING 5TH FLOOR PANEL TO AB1 VTD.  
B. PROVIDE RACEWAY AND 24/2 TWISTED PAIR FROM EXISTING 5TH FLOOR PANEL TO NEW COOLING TOWER SIDE STREAM FILTER.  
C. PROVIDE RACEWAY AND 24/2 TWISTED PAIR FROM EXISTING 5TH FLOOR PANEL TO NEW COOLING TOWER SIDE STREAM FILTER.  
D. PROVIDE RACEWAY AND CONDUCTORS TO POWER UP (120VAC) NEW 3-WAY ELECTRIC BUTTERFLY VALVE LOCATED IN MECH. ROOM 519.  
E. PROVIDE RACEWAY AND 18-2 TWISTED PAIR FROM EXISTING 5TH FLOOR PANEL (MEC-15) FOR CONTROL SIGNAL TO THE MECHANICAL ROOM 519. AS KNOWN TO HAVE ASSISTANTS ON BEINS SYSTEMS. CONTRACTORS WILL BE PROVIDED WITH ASSISTANTS REPORT FROM THE OWNER AND WILL BE REQUIRED TO ABLE THE ASSISTANTS ON SYSTEMS AND PIPING THAT ARE AFFECTED BY THIS PROJECT IN AN APPROVED MANNER.
  6. PROVIDE AND INSTALL REPLACEMENT BR BACKFLOW PREVENTOR IN SBI MECH. ROOM 519 TO ALLOW ACCESS FOR MAINTENANCE AND TESTING FOR COOLING TOWER MAKE-UP LINE.
  7. FIELD ROUTE 2" COOLING TOWER DRAW LINE TO DRAIN IN MECH. ROOM 519.
  8. DESIGN, PROVIDE AND INSTALL REPLACEMENT CHEMICAL FEED SYSTEM FOR C05/C06 SYSTEM PER SPEC 23 25 90. MATCH CURRENT WATER TREATMENT VENDOR EQUIPMENT AND CHEMICALS FOR SIMILAR USE.
- ADDITIVE BID ITEMS:**
- ABI-1 COAT EXISTING PIPING SYSTEM WITH EPOXY BARRIER COATING MATERIAL. LAW A/F.C. INSTRUCTIONS. SEE SPEC.
1. CLEAN AND COAT REMAINING PIPING SYSTEM WITH EPOXY BARRIER COATING MATERIAL. LAW A/F.C. INSTRUCTIONS. SEE SPEC.
  2. PROVIDE AND INSTALL REPLACEMENT CHEMICAL FEED SYSTEM FOR C05/C06 SYSTEM PER SPEC 23 25 90. MATCH CURRENT WATER TREATMENT VENDOR EQUIPMENT AND CHEMICALS FOR SIMILAR USE.
  3. PROVIDE TEST AND INSTALLATION PLAN WITH BID.
  4. PROVIDE VIDEO INSPECTION OF FINISHED SYSTEM AND PROVIDE DOCUMENTATION TO OWNER.
- ABI-2 REPLACE 6" C05/C06 PIPING FROM/TO COOLING TOWER FROM/TO CHILLER WITH NEW 6" SCHEDULE 40 CARBON STEEL PIPE. PAINT TO MATCH EXISTING.
1. REMOVE AND REINSTALL ALL VALVES AND PERIPHERALS INCLUDING INSTRUMENTS.
  1. REMOVE EXISTING 6" C05/C06 PIPING WITH NEW 8" SCHEDULE 40 CARBON STEEL PIPE. PAINT TO MATCH EXISTING.
- ABI-3
1. REMOVE AND REPLACE ALL VALVES TO MATCH LINE SIZE AND REINSTALL EXISTING INSTRUMENTS.
  1. REMOVE AND REPLACE THE 4" CHILLED WATER CONTROL VALVES SERVING C0-1, C0-2. REPLACE WITH 2-WAY VALVES OBTAINED FROM SUPPLIER MEETING THE PSU STANDARD.
- ABI-4

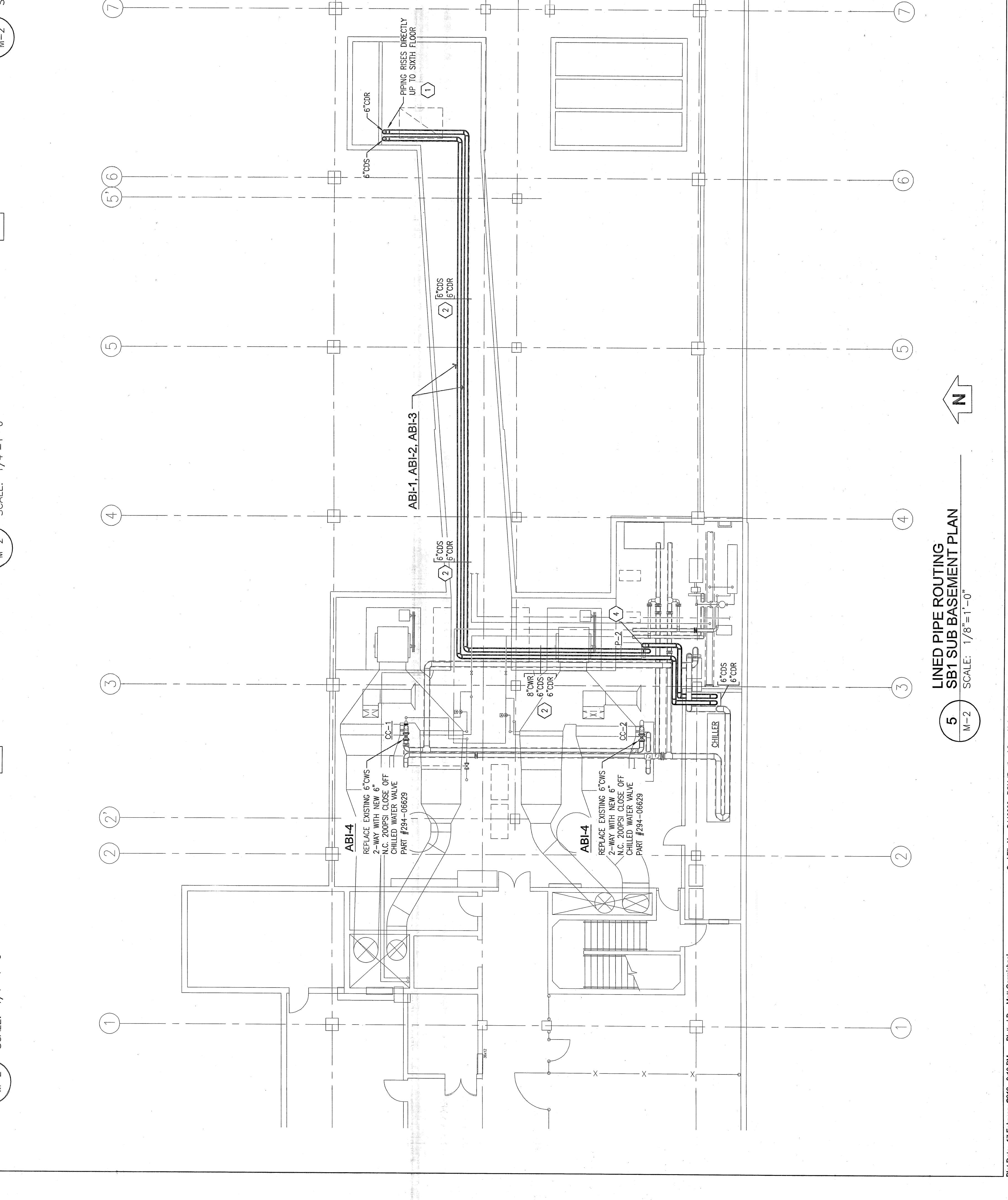
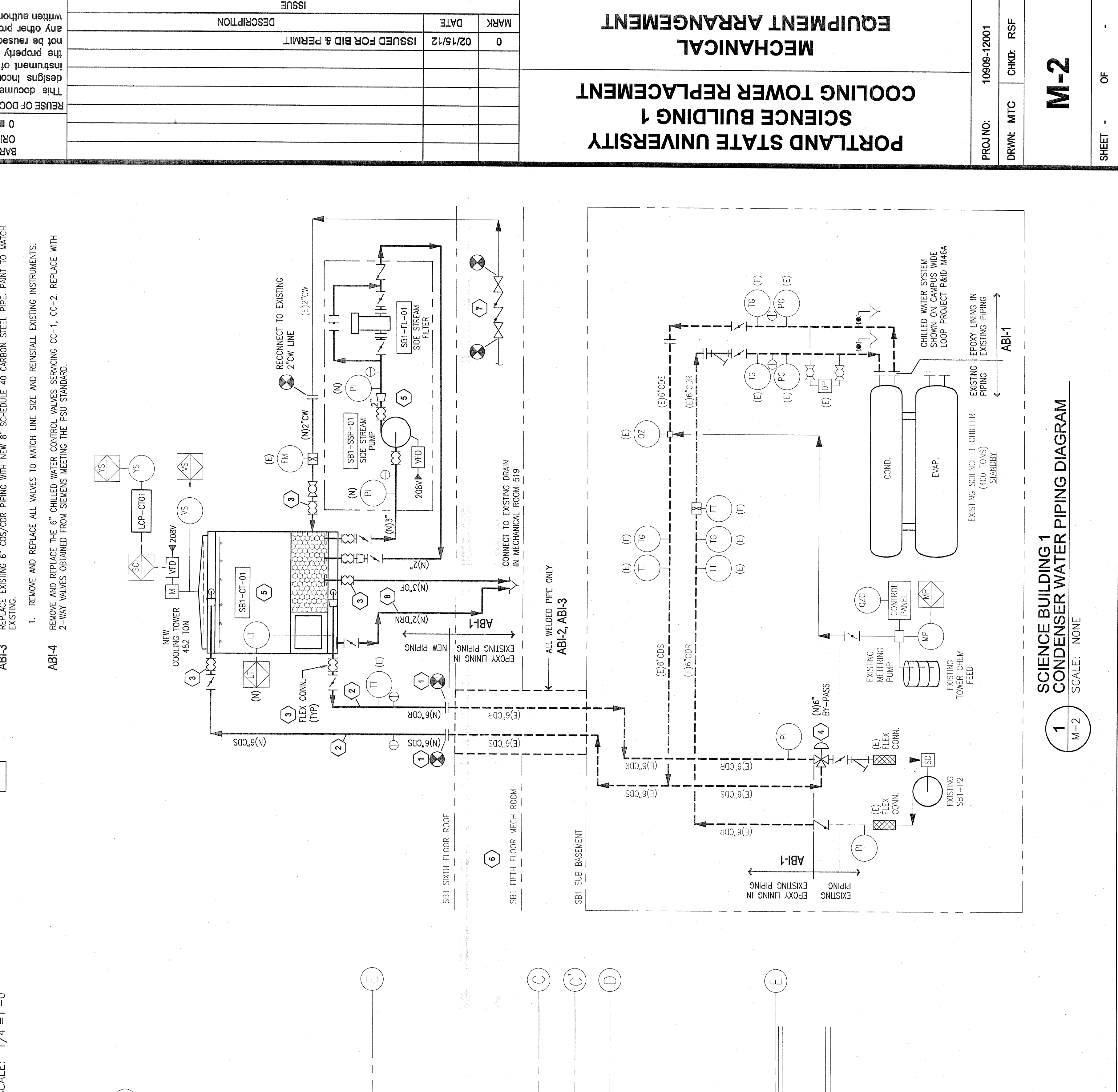
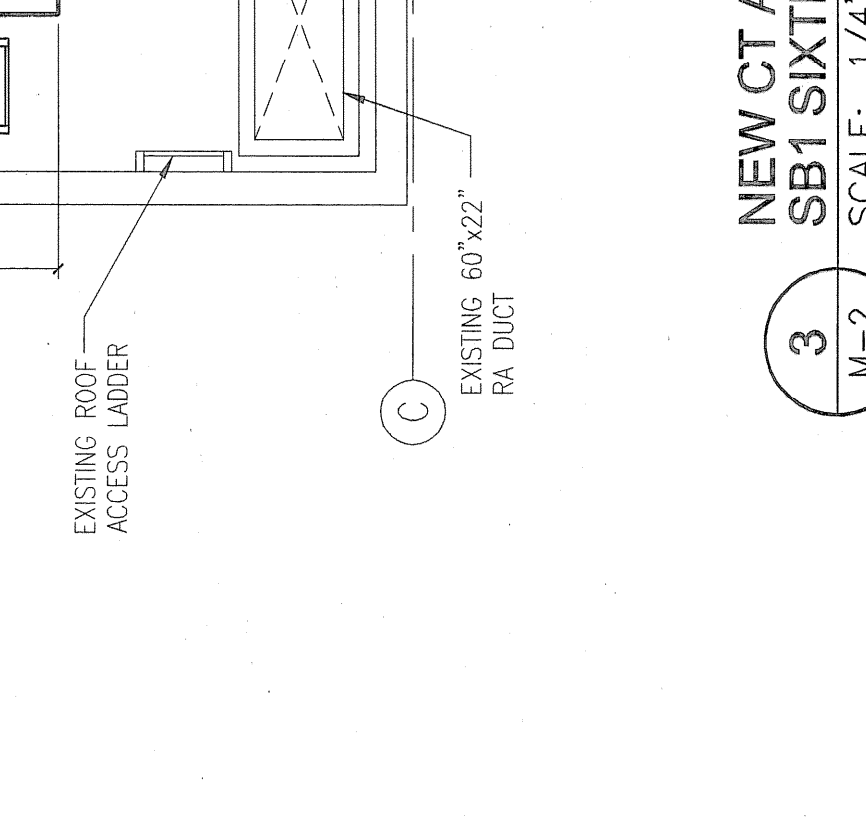
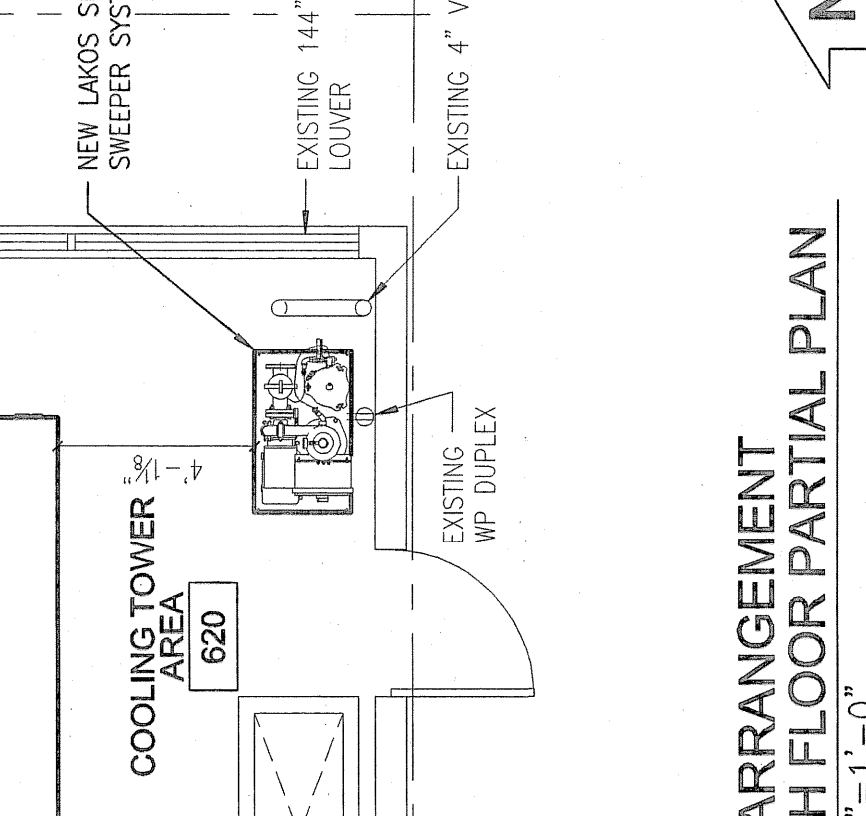
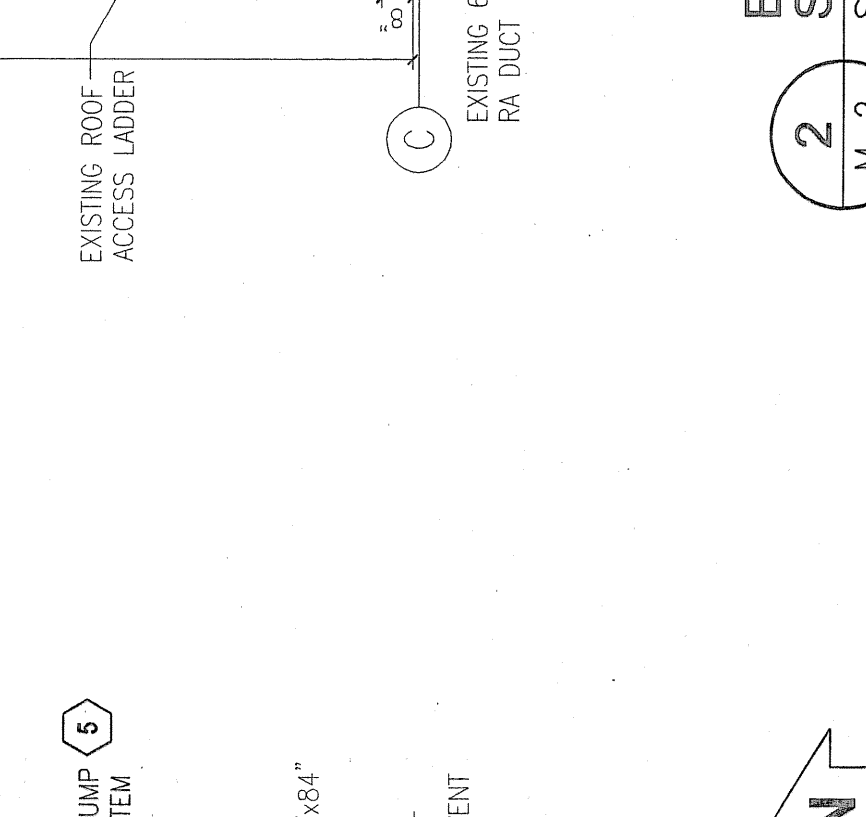
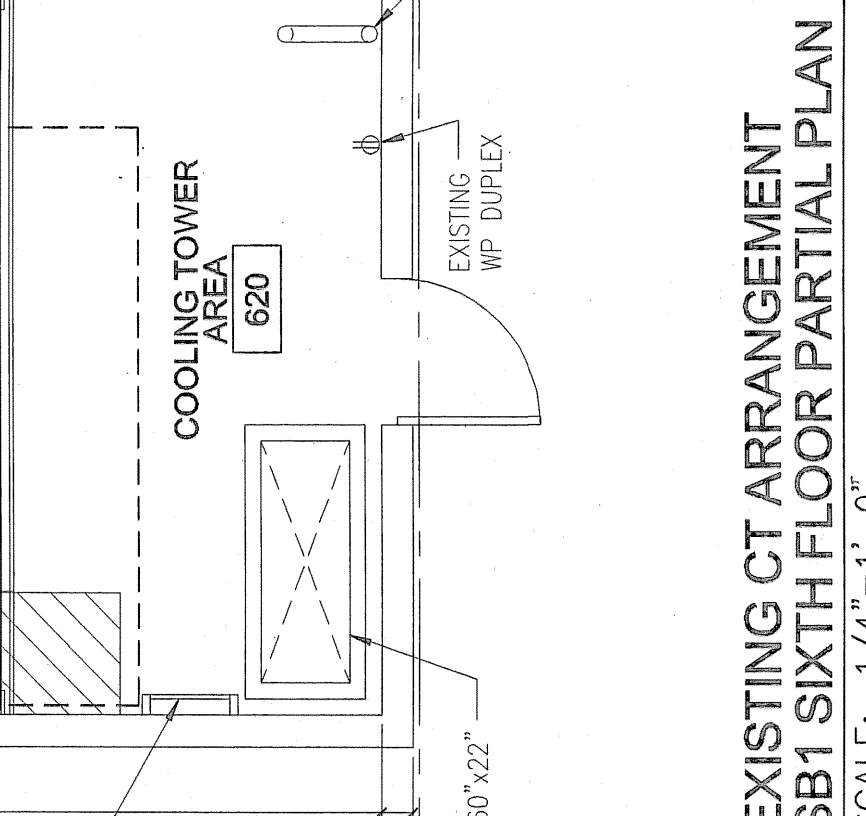
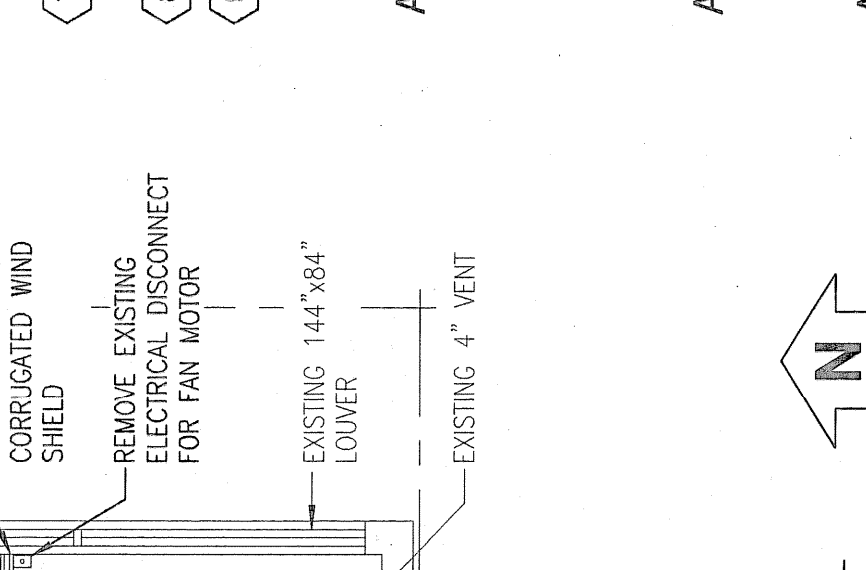
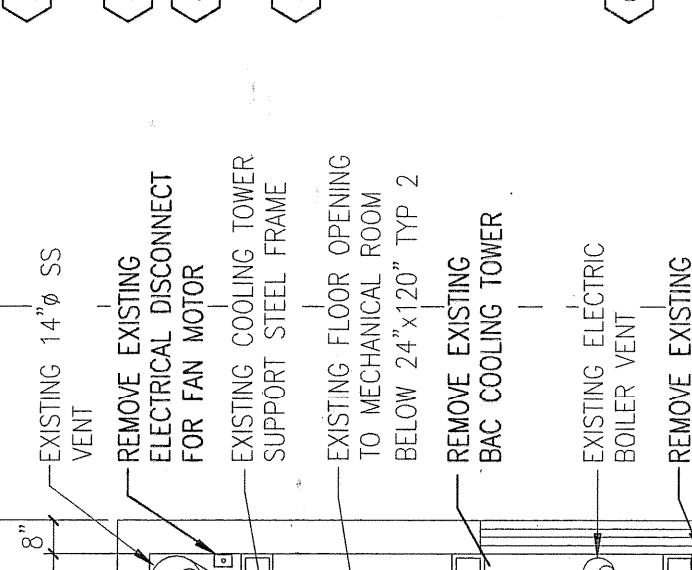



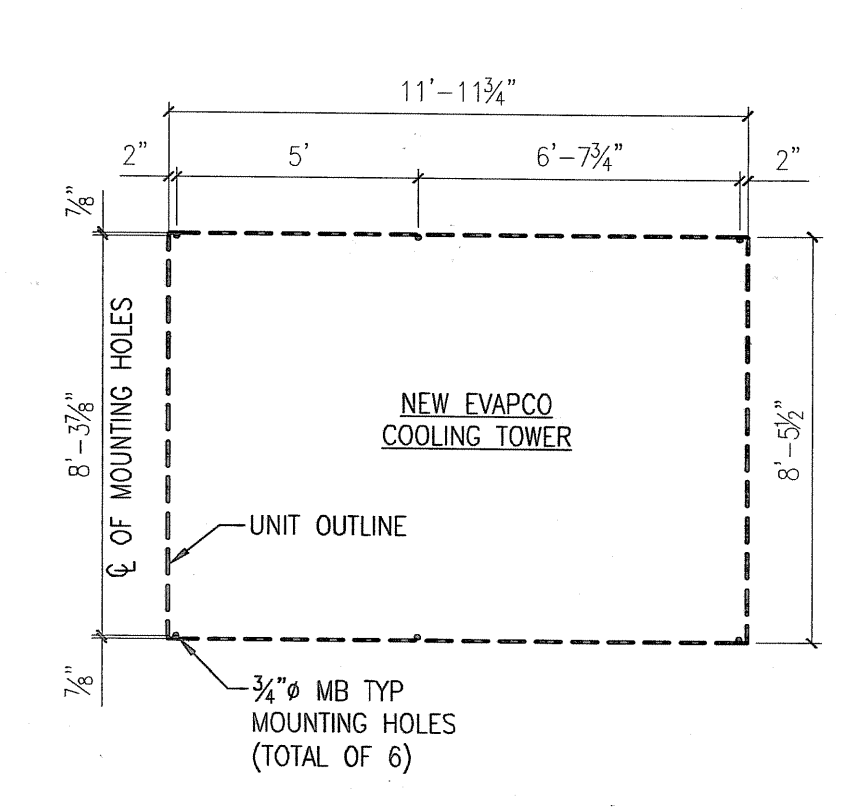

**4**  
S-1  
**COOLING TOWER MOUNTING HOLE LOCATION**  
SCALE: 1/4"=1'-0"

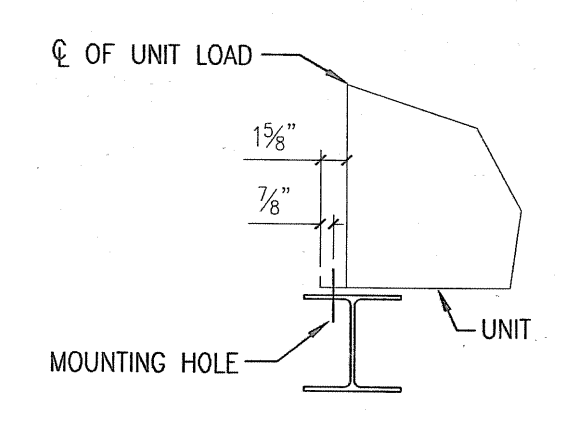

**B**  
S-1  
**TYPICAL END VIEW**  
SCALE: 1/2"=1'-0"

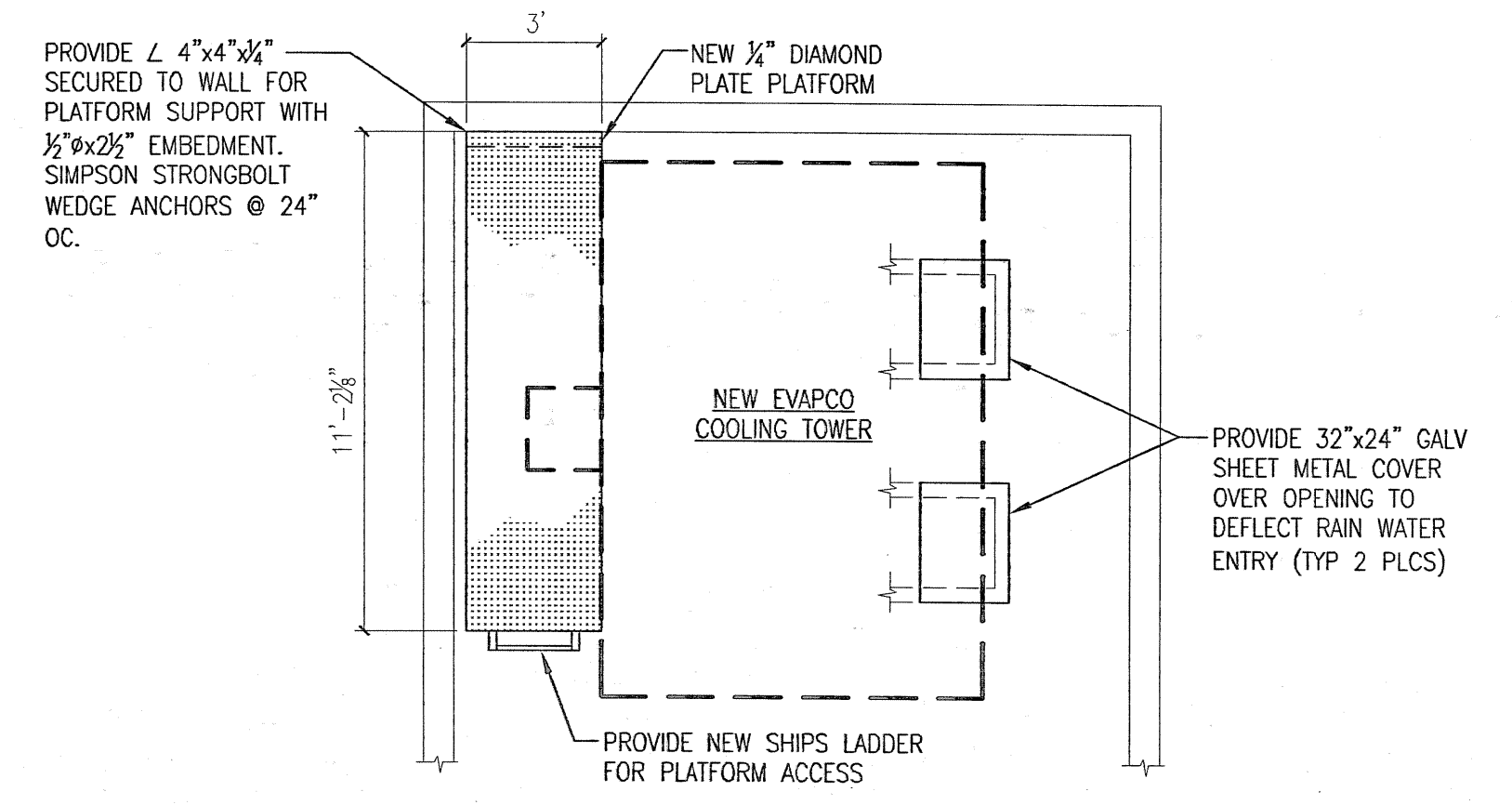

**3**  
S-1  
**CT PLATFORM PLAN VIEW**  
SCALE: 1/4"=1'-0"

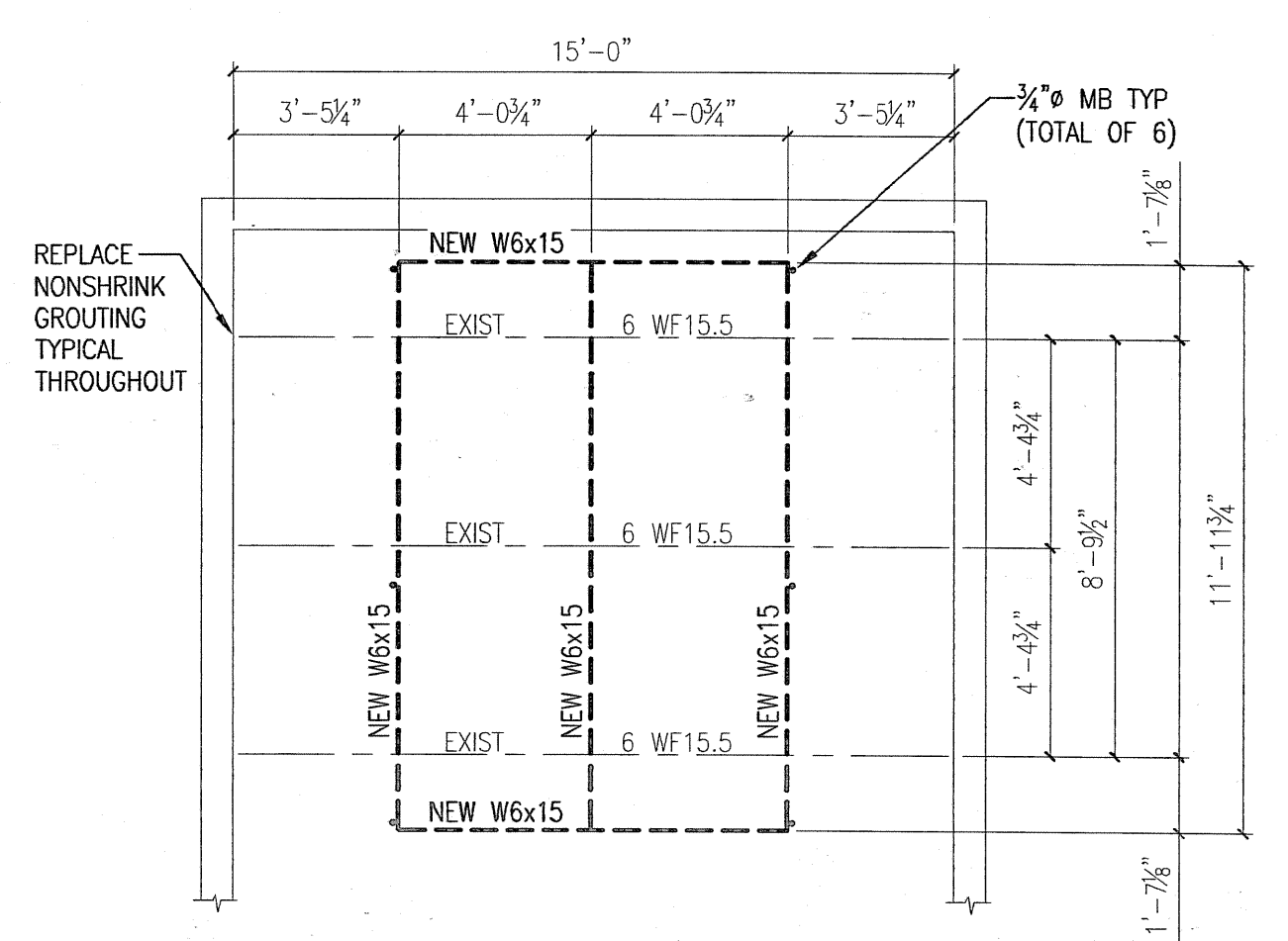

**1**  
S-1  
**CT SUPPORT PLAN VIEW**  
SCALE: 1/4"=1'-0"

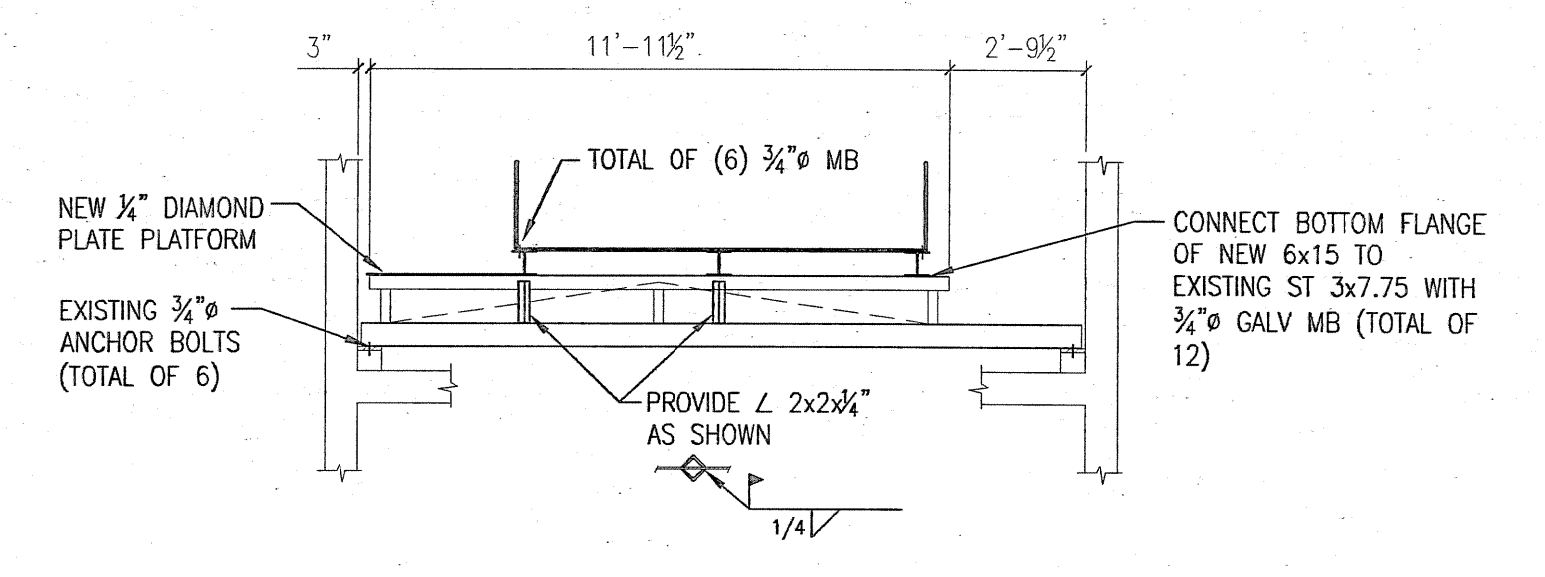

**2**  
S-1  
**SECTION**  
SCALE: 1/4"=1'-0"

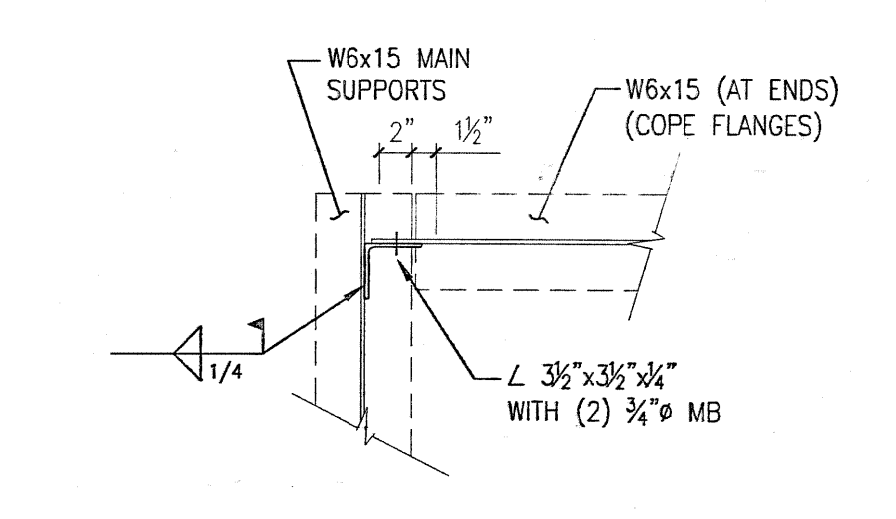

**A**  
S-1  
**MAIN SUPPORT BEAMS CONN. TO END SUPPORTS**  
SCALE: 1/2"=1'-0"

**STRUCTURAL SPECIFICATIONS:**

DESIGN STANDARD: 2009 INTERNATIONAL BUILDING CODE WITH THE 2010 OREGON STRUCTURAL SPECIALTY CODE (OSSC)

**DESIGN CRITERIA**

- DESIGN LATERAL LOADS FOR NEW CONSTRUCTION, UNLESS NOTED OTHERWISE:
  - WIND: 2010 OSSC 1609.1.1 EXCEPTION 5  
95 MPH EXPOSURE B W = 1.0
  - SEISMIC: INTERNATIONAL BUILDING CODE SEISMIC DESIGN CATEGORY D  
SITE CLASSIFICATION C...  
OCCUPANCY TYPE II  
SI = 0.35 SS = 0.99

**GENERAL**

- THESE STRUCTURAL NOTES ARE A SUPPLEMENT TO THE SPECIFICATIONS.
  - SPECIFICATIONS AND CODES REFERENCED ARE THE VERSIONS MOST RECENTLY ADOPTED BY THE PERMITTING AUTHORITY.
  - VERIFY THE DIMENSIONS AND CONDITIONS WITH THE ARCHITECTURAL DRAWINGS. FIELD VERIFY DIMENSIONS AND ELEVATIONS RELATIVE TO THE EXISTING STRUCTURE PRIOR TO FABRICATION OF MATERIALS.
  - APPLY, PLACE, ERECT OR INSTALL ALL PRODUCTS AND MATERIALS IN ACCORDANCE WITH THE MANUFACTURER'S INSTRUCTIONS.
  - ADEQUATELY BRACE STRUCTURE AND ALL STRUCTURAL COMPONENTS AGAINST WIND, LATERAL EARTH AND SEISMIC FORCES UNTIL THE PERMANENT LATERAL-FORCE RESISTING SYSTEMS HAVE BEEN INSTALLED.
  - SUBMITTALS:
    - SUBMIT SHOP DRAWINGS FOR:
      - STRUCTURAL STEEL
      - METAL DECK
    - SUBMIT SHOP DRAWINGS, STAMPED BY A REGISTERED STRUCTURAL ENGINEER LICENSED IN THE STATE OF OREGON, FOR:
      - STEEL JOISTS AND GIRDERS
      - STEEL JOISTS AND GIRDERS
    - SUBMIT SHOP DRAWINGS PRIOR TO FABRICATION OF MATERIAL.
    - ALL DAMAGED PAINT AREAS ON EXISTING STEEL MEMBERS TO BE CLEANED, PRIMED, AND PAINTED.
- NOTE: IN CASE OF ANY DISCREPANCIES OR OTHER QUESTIONS, NOTIFY ENGINEER BEFORE ANY RELATED WORK IS DONE.

**ANCHORS IN CONCRETE AND MASONRY**

- INSTALL ACCORDING TO MANUFACTURER'S RECOMMENDATIONS.
- INSTALL WITH IBC SPECIAL INSPECTION ACCORDING TO SPECIAL INSPECTION PROGRAM.
- EXPANSION ANCHORS (CONCRETE):
  - ICC/AC308-APPROVED; CONFORM WITH FF-S-325, GROUP II, TYPE4, CLASS1.
  - MATERIAL: ZINC PLATED ACCORDING TO ASTM B 633, HOT-DIPPED GALVANIZED ACCORDING TO ASTM A 153.
  - ACCEPTABLE ANCHORS:
    - TUBBOLT, BY ITW RAMSET/RED HEAD
    - POWER-STUD, BY POWER FASTENING INC.
    - "WIK-BOLT III", BY HELIX FASTENING SYSTEMS, INC.
    - WEDGE-ALL BY SIMPSON STRONG-TIE COMPANY, INC.

**NON-SHRINK GROUT**

- CONFORM WITH ASTM C 1107 AND C.R.D.-621, CORPUS OF ENGINEERS "SPECIFICATIONS FOR NON-SHRINK GROUT".
- SPECIFIED 28-DAY COMPRESSIVE STRENGTH: 5,000 PSI.
- DO NOT PRE-GROUT BASE PLATES.

**STRUCTURAL STEEL**

- FABRICATE, ERECT, IDENTIFY AND PAINT STRUCTURAL STEEL ACCORDING TO AISC SPECIFICATIONS.
- MATERIAL:
  - A AND WT SHAPES: ASTM A-36; FY = 50 KSI
  - GALVANIZED BOLTS (WHERE SHOWN ON DRAWINGS): HOT-DIPPED GALVANIZED ACCORDING TO ASTM A 153, CLASS C.
  - PROVIDE BEVELED WASHERS AT BOLT HEADS OR NUTS BEARING ON SLOPING SURFACES.
- WELDING:
  - CONFORM WITH AWS SPECIFICATIONS.
  - WELDERS TO BE QUALIFIED UNDER AWS SPECIFICATIONS.
  - WELDS MATERIAL: 70 SKI FILLER METAL, UNLESS NOTED OTHERWISE. PROVIDE LOW-HYDROGEN FILLER METALS AT MOMENT FRAME WELLS.
  - WELDS TO METAL DECK, METAL STUDS OR OTHER COLD-FORMED METALS; CONFORM TO AWS D1.3.
  - WELDING OF REINFORCING STEEL: AS NOTED IN "CONCRETE REINFORCING STEEL" PORTION OF STRUCTURAL NOTES.
  - WELDS TO GALVANIZED STEEL AND AREAS DAMAGED BY WELDING, FLAME CUTTING OR HANDLING: CLEAN, DRY AND REMOVE OIL, GREASE, SALT AND CORROSIIVE PRODUCTS. APPLY ORGANIC COLD GALVANIZING COMPOUND WITH A MINIMUM OF 94% ZINC DUST IN THE DRY FILM. APPLY IN MULTIPLE COATS TO ACHIEVE AN 8 MIL THICKNESS.
- CONTRACTOR TO DESIGN AND PROVIDE ERECTION AIDS (BOLTS, CLIPS, SHIMS, SEATS, ETC) REQUIRED TO FACILITATE CONSTRUCTION.

**SPECIAL INSPECTION PROGRAM**

EXPANSION BOLT INSTALLATION--CONTINUOUS INSPECTION PER ICC/IBCO EVAL REPORT

**SPECIAL INSPECTION PROGRAM FOOTNOTES:**

- PROVIDE SPECIAL INSPECTION, SPECIAL TESTING, REPORTING AND COMPLIANCE PROCEDURES ACCORDING TO CHAPTER 17 OF THE INTERNATIONAL BUILDING CODE WITH THE 2007 OREGON STRUCTURAL SPECIALTY CODE.
- SPECIAL INSPECTOR QUALIFICATIONS: DEMONSTRATE COMPETENCE TO THE SATISFACTION OF THE BUILDING OFFICIAL FOR INSPECTION OF THE PARTICULAR TYPE OF CONSTRUCTION OR OPERATION IN QUESTION.
- PRIOR TO THE BEGINNING OF CONSTRUCTION, REVIEW THE SPECIAL INSPECTION REQUIREMENTS WITH THE ARCHITECT, ENGINEER, BUILDING OFFICIAL, GENERAL CONTRACTOR AND SPECIAL INSPECTORS.
- DUTIES OF THE SPECIAL INSPECTOR INCLUDE, BUT ARE NOT LIMITED TO:
  - OBSERVE THE WORK FOR CONFORMANCE WITH THE APPROVED PERMIT DRAWINGS AND SPECIFICATIONS. BRING DISCREPANCIES TO THE IMMEDIATE ATTENTION OF THE GENERAL CONTRACTOR FOR CORRECTION, THEN, IF UNCORRECTED, TO THE ENGINEER AND TO THE BUILDING OFFICIAL.
  - FURNISH INSPECTION REPORTS FOR EACH INSPECTION TO THE BUILDING OFFICIAL, ARCHITECT, ENGINEER, GENERAL CONTRACTOR AND OWNER IN A TIMELY MANNER.
  - SUBMIT A FINAL REPORT STATING WHETHER THE WORK REQUIRING SPECIAL INSPECTION WAS INSPECTED, AND WHETHER THE WORK IS IN CONFORMANCE WITH THE APPROVED PERMIT DRAWINGS AND SPECIFICATIONS.
- DUTIES OF THE GENERAL CONTRACTOR INCLUDE, BUT ARE NOT LIMITED TO:
  - NOTIFY SPECIAL INSPECTOR THAT WORK IS READY FOR INSPECTION AT LEAST 24 HOURS BEFORE INSPECTION IS REQUIRED.
  - MAINTAIN ACCESS TO WORK REQUIRING SPECIAL INSPECTION UNTIL IT HAS BEEN OBSERVED AND INDICATED TO BE IN CONFORMANCE BY THE SPECIAL INSPECTOR AND APPROVED BY THE BUILDING OFFICIAL.
  - PROVIDE THE SPECIAL INSPECTOR WITH ACCESS TO APPROVED PERMIT DRAWINGS AND SPECIFICATIONS AT THE JOB SITE.
  - MAINTAIN JOB-SITE COPIES OF ALL REPORTS SUBMITTED BY THE SPECIAL INSPECTOR.
- DEFINITIONS:
  - CONTINUOUS INSPECTION: THE INSPECTOR IS OBSERVING THE WORK REQUIRING SPECIAL INSPECTION AT ALL TIMES.
  - PERIODIC INSPECTION: THE SPECIAL INSPECTOR IS ON SITE AS REQUIRED TO CONFIRM THAT THE WORK REQUIRING SPECIAL INSPECTION IS IN CONFORMANCE.

**STRUCTURAL OBSERVATION**

STRUCTURAL OBSERVATION, IN ACCORDANCE WITH SECTION 1709 OF THE INTERNATIONAL BUILDING CODE, SHALL BE PERFORMED BY THE ENGINEER OF RECORD, IN THE FOLLOWING SEQUENCE. THE GENERAL CONTRACTOR SHALL CONTACT THE STRUCTURAL ENGINEER OF RECORD, FIVE (5) WORKING DAYS PRIOR TO COMPLETION OF THE STAGE INDICATED BELOW TO COORDINATE THE DATE OF OBSERVATION:

- STEEL FRAMING: AFTER THE ROOF FRAMING HAS BEEN ERECTED

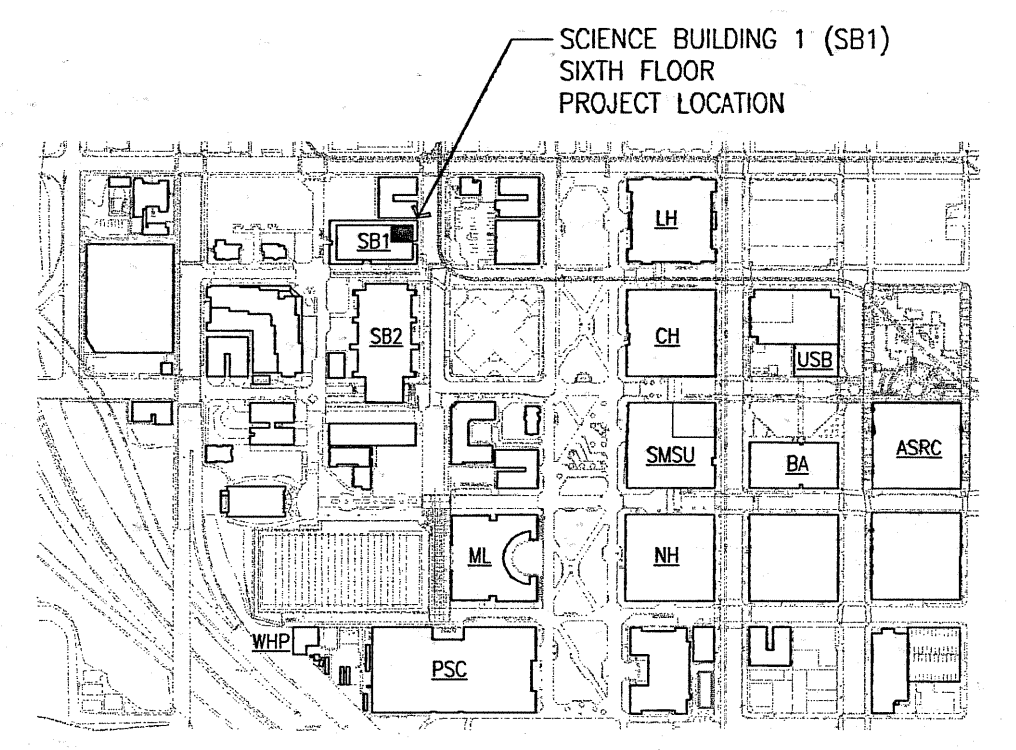

PSU CAMPUS - KEY PLAN



GHD Inc.  
718 Third Street Eureka California 95501 USA  
T 1 707 443 8328 F 1 707 444 8330  
W www.ghd.com

REGISTERED PROFESSIONAL ENGINEER  
EXPIRES 6/30/2018

MARK	DATE	DESCRIPTION	ISSUE
0	02/15/12	ISSUED FOR BID & PERMIT	

PORTLAND STATE UNIVERSITY  
SCIENCE BUILDING 1  
COOLING TOWER REPLACEMENT  
STRUCTURAL  
COOLING TOWER FRAMING PLAN

PROJ NO: 10909-12001  
DRWN: MTC CHKD: JSH

**S-1**  
SHEET - OF -

PROGRESSIVE CONSULTANTS, INC.  
8100 NE PARKWAY DRIVE, SUITE #40  
VANCOUVER, WA 98662  
(360) 254-8400 FAX (360) 254-3334