



Oregon State University

RICHARDSON HALL CHILLER AND CONTROLS REPLACEMENT CM/GC

PROJECT NUMBER: 223923

RFP #2023-010261

ADDENDUM NO. 2

ISSUE DATE: December 20, 2022

CONTRACT ADMINISTRATOR:

Brooke Davison, Construction Contracts Officer

Construction Contracts Administration

Email: ConstructionContracts@oregonstate.edu

This Addendum is hereby issued to inform you of the following revisions and or clarifications to the above-referenced RFP and/or the Contract Documents for the Project, to the extent they have been modified herein. Any conflict or inconsistency between this Addendum and the Solicitation Document or any previous addenda will be resolved in favor of this Addendum. Proposals shall conform to this Addendum. Unless specifically changed by this Addendum, all other requirements, terms and conditions of the Solicitation Document and or Contract Documents, and any previous addenda, remain unchanged and can be modified only in writing by OSU. The following changes are hereby made:

REFERENCE/SUPPLEMENTAL MATERIALS:

- Item 1 Richardson Hall Chiller Replacement Study, Systems West Engineers, December 14, 2022, attached.
- Item 2 Richardson Hall HVAC Upgrades Study, Systems West Engineers, December 16, 2022, attached.

END OF ADDENDUM NO. 2



DECEMBER 16, 2022

Richardson Hall HVAC Upgrades

V015.24

725 A Street Springfield, OR 97477

550 NW Franklin Blvd., Suite 448 Bend, OR 97703



SystemsWestEngineers.com

(541) 342-7210

TABLE OF CONTENTS

- Introduction 1
- Project Objectives 1
- Facility Description 1
- System Evaluation Summary 2
- Recommended Facility Improvements..... 2
 - Base Scope of Work 2
 - High Priority Recommendations 3
- Steam Systems 3
 - Heating Water System 3
 - Chilled Water System..... 3
- Air Distribution Systems 3
 - Lower Priority 4
 - Scope of Work 4
- Heating Water System 4
 - Chilled Water System..... 4
 - Air Distribution Systems 4
- Project Cost Summary 4
 - Base Scope of Work..... 4
 - High Priority Recommendations 5
 - Low Priority Recommendations 6
- Implementation Summary 6
 - Facility Description 6
 - Site Investigation..... 7
 - HVAC System Descriptions..... 7
 - Steam Systems..... 7
 - Hot Water Heating Systems 7
 - Steam-to-Hot Water Converter 8
 - Heating Water Pumps 8
 - Notable Conditions: 8
 - Chilled Water Systems..... 8
 - Richardson Hall Building Chilled Water System 8

| | |
|--|----|
| Richardson Hall Insect-Rearing Laboratory Chilled Water System | 13 |
| Peavy Hall Chilled Water System | 14 |
| Peavy Hall Condenser Water System | 17 |
| Air Distribution Systems | 18 |
| Administration Wing | 19 |
| Laboratory Wing..... | 20 |
| High Bay and Kiln..... | 36 |
| Building Automation Systems..... | 37 |
| System Evaluation | 38 |
| Heating, Ventilating, and Air-Conditioning..... | 38 |
| Steam Systems | 38 |
| Hot Water Heating Systems | 39 |
| Hydronic Water Quality | 39 |
| Heating Water Pump Upgrades..... | 39 |
| Chilled Water System..... | 39 |
| Richardson Hall Building Chilled Water System | 39 |
| Richardson Hall Insect Rearing Laboratory Chilled Water System | 42 |
| Peavy Hall Chilled Water System | 43 |
| Richardson and Peavy Hall Condenser Water System..... | 43 |
| Air Distribution Systems | 45 |
| Administration Wing | 45 |
| Laboratory Wing..... | 46 |
| Recommended Facility Improvements..... | 53 |
| Base Scope of Work | 54 |
| High Priority Recommendations..... | 54 |
| Steam Systems | 54 |
| Heating Water System | 54 |
| Chilled Water System..... | 54 |
| Air Distribution Systems | 55 |
| Lower Priority Scope of Work..... | 56 |
| Heating Water System | 56 |
| Chilled Water System..... | 56 |
| Air Distribution Systems | 56 |
| PROJECT COSTS | 56 |
| Budget Cost Projections..... | 56 |

| | |
|-------------------------------------|----|
| Base Scope of Work..... | 57 |
| High Priority Recommendations | 57 |
| Low Priority Recommendations | 59 |
| Implementation..... | 59 |
| Implementation Considerations | 59 |
| Steam Systems | 59 |
| Heating Hot Water..... | 59 |
| Chilled Water System Upgrades..... | 59 |
| Air Distribution Systems | 60 |

Appendixes

Appendix A – Steam Piping Diagram

Introduction

Systems West Engineers was retained by Oregon State University to assess the condition of HVAC and chilled water systems serving the Richardson Hall building and develop recommendations for system improvements.

This report combines two specific contract requirements. The first is to provide an assessment of Richardson Hall HVAC systems. The second is provide an assessment of chilled water and condenser water system that serve Richardson Hall and Peary Hall.

A separate schematic design was prepared that details base scope modifications that are currently in design. Base scope work includes chiller replacement, DDC control replacement, laboratory pressure control replacement, and wood treatment laboratory upgrades as described in the OSU Richardson Hall Chiller Plant Upgrades and HVAC Upgrades Schematic Design Narrative dated December 14,2022. Base scope work is listed in the report, but not described in detail.

Project Objectives

Oregon State has identified the following key objectives of this evaluation:

- Assess condition and function of existing building HVAC systems and identify system deficiencies and expected remaining useful life.
- Review the suitability of existing systems to maintain indoor environment and provide reliable service as appropriate for a Laboratory facility.
- Develop recommendations for system improvements including budget projections of probable construction costs.
- Provide recommendations for replacing existing chiller and chilled water plant serving Richardson Hall
 - Add Provisions for connecting a temporary chiller to the chilled water distribution system.
 - Assess the potential to again combine the chiller systems for Peavy and Richardson, either in a redundancy basis or as a singular unit.
- Provide recommendations for performing upgrades to Room 197B for the purpose of adding a wood treatment lab to the space.

Facility Description

Richardson Hall was originally constructed in 1999. The building is approximately 10,000 square feet and has three stories with a partial basement. The building includes an administration wing that is primarily office spaces and a laboratory wing that is laboratory and office space. The building has undergone a number of minor remodels, upgrades, and system improvements since originally constructed.

A detailed description of existing building conditions is contained in Section 2.

System Evaluation Summary

An in-depth analysis of HVAC systems, equipment, specific problematic and deficient conditions, and corrective options is contained in Section 3 of this report. The system evaluation section is intended to provide a focused description of the conditions that produce the recommended facility improvements.

Recommended Facility Improvements

The section identifies recommended facility improvements and provides a description of the scope of work associated with each recommendation. A detailed description of facility improvements is contained in Section 4 of this report. Facility improvements have been separated into three categories:

- **Base Scope Work:** Items in this category were identified in the original RFP and are currently in design.
- **High Priority Recommendations:** Items that are critical to the continues reliable operation of HVAC system or that provide major benefit to the University in energy savings and greenhouse gas reduction.
- **Low Priority Recommendations:** Items that are recommended, but that are not critical to the continues reliable operation of the building in the near future.

A summary of the proposed improvements is listed below.

Base Scope of Work

Improvements related to the chilled water system and controls upgrades scope of work is described in the OSU Richardson Hall Chiller Plant and HVAC Upgrades schematic design report dated December 14, 2022. This includes the following:

- Replace chiller and upgrade chilled water system.
- Clean and flush chilled water system to improve water quality.
- Replace chiller room emergency refrigerant exhaust fan.
- Replace the Siemens building automation system including replacing pneumatic control valves and damper actuators.
- Replace the Phoenix laboratory space pressure control system including automatic controls and variable volume air valves.
- Revise sequence of operations for air handling units AHU-2 and AHU-3 to include a morning warm up routine.

High Priority Recommendations

Recommendations included in this section of the report are considered high priority and are recommended for immediate implementation.

Steam Systems

- Demolish high to medium pressure steam pressure reducing valve assembly.
- Demolish abandoned high pressure steam piping between wet mechanical room and basement chiller room.
- Replace damaged steam pipe insulation in the basement wet mechanical room.

Heating Water System

- Water service treatment provider to clean and flush heating water system.
- Provide high performance filter (HPF) system on closed loop heating water system. Basis of design is Chem-Aqua hot water HPF closed loop filter.

Chilled Water System

- Provide 100-ton heat recovery chiller, piping, controls, and related appurtenances. This is in addition to the 400-ton chiller provided in the base bid.
- Upgrade insect lab chilled water system.

Air Distribution Systems

Administration Wing

- Refurbish air handler AHU-2
- Replace supply diffusers along the south perimeter walls of the administration wing.

Laboratory Wing

- Refurbish air handling unit AHU-1.
- Demolish and provide new laboratory exhaust fan EF-1.
- Demolish and provide new laboratory exhaust fans EF-5, EF-6, and EF-11.
- Recertify Insect Rearing Biological Containment Laboratory as a ABSL3Ag containment laboratory.
- Demolish and provide new laboratory exhaust fans EF-2, EF-3, EF-17 and EF-18.
- Refurbish air handling unit AHU-3
- Clean air handler AHU-4 and AHU-5.
- Replace supply diffusers along the west perimeter walls of the laboratory wing.
- Replace linear slot diffusers within the laboratory spaces with supply grilles.
- Restore run-around heat recovery system operation.
- Provide fan coils for supplemental cooling in laboratory spaces.

Lower Priority Scope of Work

Recommendations included in this section of the report are considered lower priority and may be implemented if project funding is available or planned for a future construction project.

Following is a summary of the proposed renovation work.

Heating Water System

- Demolish and provide new heating Water Pumps HWP-1 and HWP-2

Chilled Water System

- Provide interconnection of chilled water piping between Richardson Hall and Peavy Hall for chilled water redundancy.

Air Distribution Systems

Administration Wing

- Demolish and replace terminal unit reheat coil valve piping with new valves and trim. Include a strainer on the coil supply.

Laboratory Wing

- Demolish and replace terminal unit reheat and duct mounted reheat coil valve piping with new valves and trim. Include a strainer on the coil supply.
- Demolish and provide new heat recovery coil plenum.

Project Cost Summary

Following is a summary of the projected probable cost for recommended improvements described in this report. The method used for developing cost projects and key estimating factors used to develop the estimates are included in Section 5 of this report.

Base Scope of Work

| PROJECT COST SUMMARY | PROBABLE DIRECT CONSTRUCTION COST |
|--|--|
| Replace chiller and upgrade chilled water system | \$525,000 |
| Replace the Siemens BAS system including replacement of pneumatic valve and damper actuators | \$885,000 |
| Replace Phoenix laboratory space pressure control systems | \$678,750 |
| Revise sequence of operations for air handling units AHU-2 and AHU-3 to include a morning warmup | \$2,000 |

| | |
|------------------------------------|--------------------|
| Wood Treatment Lab 197B Upgrades | 235,000 |
| Subtotal | \$2,325,750 |
| Design Contingency (5%) | \$116,290 |
| Construction Contingency (10%) | \$232,600 |
| Construction Scope Subtotal | \$2,674,640 |
| General Conditions Noted Above | \$695,400 |
| Project Total | \$3,370,040 |

High Priority Recommendations

| PROJECT COST SUMMARY | PROBABLE DIRECT CONSTRUCTION COST |
|--|--|
| Steam system upgrades | \$20,000 |
| Heating water system upgrades | \$16,000 |
| Chilled water system upgrades Install heat recovery chiller Upgrade insect lab chiller CH-2 and associated chilled water system. | \$370,000 |
| Upgrade AHU-1 | \$150,000 |
| Upgrade air handler AHU-2 | \$75,000 |
| Replace supply diffusers in administration wing and laboratory wings | 50,000 |
| Replace exhaust fan EF-1 | \$500,000 |
| Replace laboratory exhaust fans EF-2, EF-3, EF-5, EF-6, EF-11, EF-17, and EF-18 | 80,000 |
| Upgrade air handler AHU-3 | 75,000 |
| Clean air handlers AHU-4 & AHU-5 | 20,000 |
| Restore heat recovery system operation | 35,000 |
| Provide fan coils for supplemental cooling | 160,000 |
| Subtotal | \$1,551,000 |
| Design Contingency (15%) | \$235,650 |
| Construction Contingency (10%) | \$155,100 |
| Construction Scope Subtotal | \$1,941,750 |
| General Conditions Noted Above | \$504,900 |

| | |
|---------------|-------------|
| Project Total | \$2,446,650 |
|---------------|-------------|

Low Priority Recommendations

| PROJECT COST SUMMARY | PROBABLE DIRECT CONSTRUCTION COST |
|---|-----------------------------------|
| Upgrade heating water system | \$40,000 |
| Upgrade chilled water system | \$150,000 |
| Replace reheat coil valves and piping | \$200,000 |
| Replace existing heat recovery exhaust plenum | \$110,000 |
| Recertify insect rearing laboratory | \$350,000 |
| Subtotal | \$850,000 |
| Design Contingency (15%) | \$127,500 |
| Construction Contingency (10%) | \$85,000 |
| Construction Scope Subtotal | \$1,062,500 |
| General Conditions Noted Above | \$276,250 |
| Project Total | \$1,338,750 |

Implementation Summary

Some recommendation will interrupt operation of critical system or must be performed during the appropriate season to a suitable indoor environment. A detailed description of implementation and a phasing consideration included in Section 6.

FACILITY DESCRIPTION

The Richardson Hall building was originally constructed in 1999. The building is approximately 100,000 square feet and includes a partial basement, and three floors. The building has undergone several minor remodels, upgrades, and system improvements since originally constructed. Many building systems are original to the 1999 construction and are past their expected useful life. Some notable exceptions include:

- Cooling towers were installed during the Peavy Hall project in 2015 and serve both Richardson Hall and Peavy Hall.
- The Richardson Hall water chiller was installed in 2004. It was sized to provide chilled water to Richardson Hall and the original Peavy Hall. The chilled water supply to Peavy Hall was disconnected in 2017.

The following is a description of some of the most notable HVAC system deficiencies.

- The water-cooled chiller is oversized and not able to provide reliable cooling to the building during low load conditions.

- HVAC systems are not able to provide adequate cooling to the administration and laboratory wings of the building.
- The existing pneumatic control system leaks and is unreliable.

Site Investigation

Systems West Engineers and Landis Consulting conducted site visits to Richardson Hall and met with facility staff, reviewed record drawings and documentation, and performed visual observations to determine the current configuration and condition of systems and equipment. Where available, equipment identification, nameplate data, and performance information were recorded.

HVAC System Descriptions

Following is a description of existing systems, equipment, and notable conditions:

Steam Systems

Richardson Hall was originally designed to be supplied with 115-psi high pressure steam to supply an absorption chiller and kilns. There are two steam pressure reducing valve headers in the basement mechanical room. The first is designed to reduce the high-pressure steam to 55-psi medium pressure steam that is supplied to autoclaves in the insect rearing quarantine lab room 387. The second reduces the medium pressure steam to 15-psi low pressure steam that is supplied to the following equipment:

- Steam-to-hot water converter
- Domestic water heater
- Lab hot water heater
- Lab hoods in rooms 167, 185, 187, and 191

A schematic diagram of the steam system is included in Appendix A.

Notable Conditions:

- Campus steam distribution systems currently supply 60-psi steam to Richardson Hall.
- Building users have indicated that the existing steam gauge near the kiln is reading 80 psi and that steam capacities near 100 psi are desired to accelerate drying times.
- The high-pressure steam pressure reducing valve header is no longer needed.
- The absorption chiller has been removed from the building. Steam piping that used to serve the absorption chiller has been abandoned in place.
- Steam piping in the basement mechanical room has damaged insulation.

Hot Water Heating Systems

The heating water system has the following elements:

- Steam-to-hot water converter
- Heating water distribution system

Steam-to-Hot Water Converter

Heating hot water is supplied to the building from a steam-to-water converter in the basement mechanical room. Two steam control valves vary the steam supply to the converter to meet building heating loads. The converter has the following characteristics and design performance:

- Heating Capacity 8,817-MBH
- Steam 15-psi
- Flow 440-gpm
- Entering Water Temperature 140F
- Leaving Water Temperature 180F

Heating Water Pumps

Heating water pumps HWP-1 and HWP-2 are end suction pumps in the basement mechanical room. They circulate heating water from the steam-to-heating water converter to heating coils throughout the building. The pumps have the following characteristics and design performance:

- Model Bell & Gossett 1510
- Flow 450-gpm
- Head 80-feet
- Motor Horsepower 15HP

The pumps operate in a lead lag configuration and are 100% redundant.

Notable Conditions:

- Heating hot water quality is poor. There is sediment and corrosion in the piping system.
- Heating water pumps HWP-1 and HWP-2 were installed in 1999 and are past their expected service life expectancy of 20 years.
- The steam-to-heating water converter is at the end of its expected service life of 24 years.

Chilled Water Systems

Two chilled water systems provide cooling for Richardson Hall. A centralized water-cooled chiller plant located in the basement mechanical room serves most of the building. An independent air-cooled chiller serves the insect rearing containment laboratory. Additionally, the building chilled water system in Richardson Hall is partially integrated with the Peavy Hall chilled water system.

The following is a description of the existing chilled water systems serving Richardson Hall and Peavy Hall along with notable conditions observed during an on-site field survey.

Richardson Hall Building Chilled Water System

The chilled water system serving a majority of Richardson Hall is configured in a primary-secondary arrangement and provides chilled water to air handling units AHU-1, AHU-2, and AHU-3. The system has a cooling capacity of 510 tons with a maximum secondary flow of 660 gpm. The chiller plant total connected cooling load is 410 tons with a design flow of 845 gpm.

A schematic of the building chilled water system is shown in Figure 1 below. The building chilled water plant includes the following major elements:

- Chillers
- Primary chiller pump
- Secondary distribution pump
- Intertie pump
- Condenser water pump
- Emergency refrigerant exhaust system
- Building automation system

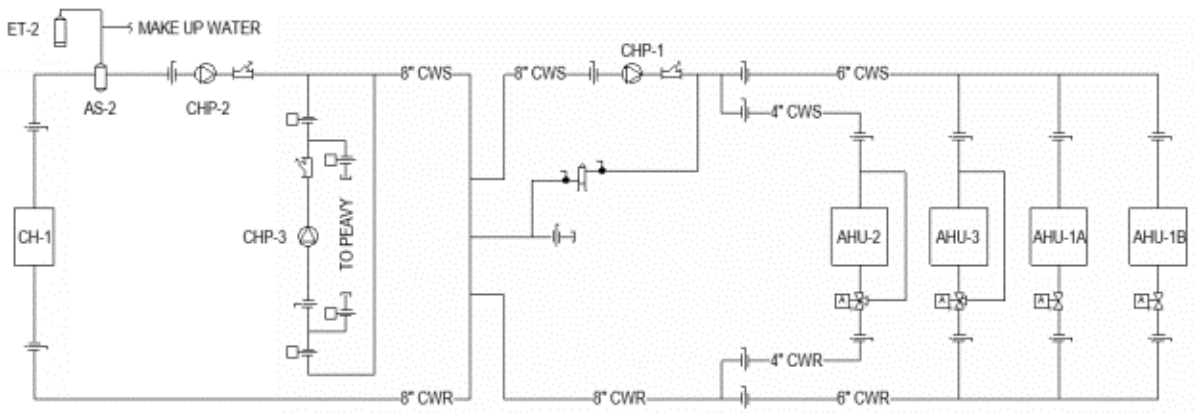

Figure 1 Richardson Hall Building Chilled Water Diagram

System Modifications

The Richardson Hall chiller plant has experienced several major modifications since its original construction in 1997.

- **Chiller Replacement:** The chiller plant was originally constructed with a 600-ton double effect absorption chiller. The chiller was designed to use 115 psig campus steam that was delivered to the building at that time. The chiller was purchased “used” and was oversized for the original design capacity of 490 tons. The chiller did not perform well, and the University opted to reduce steam supply pressure to 60 psig. Accordingly, the absorption chiller was replaced in 2004 with the current electric centrifugal chiller.
- **Cooling Tower Replacement:** Design of the original cooling towers was problematic. The cooling towers were installed in the equipment service yard adjacent to the chiller room. The cooling tower basins were only a few feet above the condenser water pump inlet which caused two adverse conditions. Air entrainment into the cooling tower outlet caused significant air impingement at the condenser water pump impeller. Low pump suction pressure also resulted in cavitation at the pump inlet. Both conditions caused damage to the condenser water pump impeller.

In addition, a leak occurred in the buried condenser water piping to Peavy Hall. The leak resulted in large quantities of make-up water over an extended period of time. Make-up water at OSU is relatively soft and reacted aggressively with the galvanized coating on the cooling tower basins. During the period of the leak, a majority of the galvanic coating on the cooling towers was removed.

Ultimately, the cooling towers were replaced in 2004 when the chiller was replaced.

- Peavy Hall Demolition: The Richardson Hall chilled water and condenser water systems were integrated with systems in Peavy Hall. The chilled water system was configured with a transfer pump that enabled chilled water to be supplied from Richardson Hall to Peavy Hall, or from Peavy Hall to Richardson Hall. The chilled water interconnection was disabled when Peavy Hall was demolished. Some remnants of this interconnection remain in the Richardson Hall mechanical room. It should be noted that the chiller installed in 2004 was sized with some allowance to provide cooling to Peavy Hall.
- Peavy Hall Replacement: The replacement of Peavy Hall included replacement of the Richardson Hall cooling towers. An enlarged and integrated condenser water system was provided to serve the chillers in Richardson Hall and Peavy Hall.

Chiller

Chilled water for building cooling is provided by a water-cooled chiller CH-1 located in basement mechanical room. The chiller has the following characteristics and design performance:

- Model: Carrier 19XRV
- Capacity: 510 tons
- Compressor Type: Centrifugal
- Chilled Water Flow: 1,175 gpm
- Chilled Water Temperatures: 54°F in, 44°F out
- Condenser Water Flow: 1,000 gpm
- Chilled Water Temperatures: 75°F in, 89°F out

Chiller operation has been problematic for some time. The unit does not appear to be well suited for this application. Several conditions contribute to this issue:

Chiller Capacity: The chiller has a design capacity of 510 tons; however, the maximum building cooling load is 410 tons without the AHU-1 run-around heat recovery system operating. With the heat recovery system in operation, the peak building load would be approximately 300 tons. This is only 60% of the chiller design capacity. The chiller can be expected to operate well when outside air temperature is above 80°F to 85°F; however, during periods when the outside air temperature is less than 80°F the chiller has difficulty operating at low load condition.

Tube Fouling: One particular issue that has occurred in recent years is the accelerated fouling of the evaporator tubes. Fouling is caused by poor hydronic water quality in the chilled water system. It was reported that last year the chiller would have to be off-line for tube cleaning on a regular basis. This left the building without cooling for an extended period of time.

Chiller Redundancy: The chiller plant has no redundant cooling equipment. There is one chiller, and if that unit is not operable then the building will not have cooling. One primary objective for improvement of Richardson Hall will be the enhancement of chiller plant operational reliability, which will require more redundant equipment components.

Primary Chiller Pump

Primary pump CHP-2 operates at a constant flow circulating water through chiller CH-1. The pump includes the following characteristics and design performance:

- Model: TACO FE600
- Flow: 1175 gpm
- Head: 45 ft
- Motor Horsepower: 20 hp

The primary pump operates whenever the chiller is on.

Pump Redundancy: There is one primary pump. If that unit is not operable the building will not have cooling.

Secondary Chilled Water Distribution Pump

The secondary pump CHP-2 operates at a variable flow to provide chilled water to cooling coils in air handling units AHU-1, AHU-2, and AHU-3 on the roof. The pump includes the following characteristics and design performance:

- Model: TACO FE600
- Flow: 660 gpm
- Head: 70 ft
- Motor Horsepower: 15 hp

The secondary pump operates whenever the chiller is on. Pump speed is controlled to maintain a pressure differential in the piping distribution system.

Pump Redundancy: There is one secondary pump. If that unit is not operable, then the building will not have cooling.

Richardson/Peavy Intertie Chilled Water Pump

The chilled water system was originally configured with an intertie transfer pump CHP-3 that enable chilled water to be supplied from Richardson Hall to Peavy Hall or from Peavy Hall to Richardson Hall. Automatic control valves at the interconnect piping header allowed chilled water to be redirected in both directions. The interconnection of chilled water plants including pumps, controls, and piping was abandoned in place when Peavy Hall was demolished in 2017.

Primary Condenser Water Pump

The primary pump CWP-1 operates at a constant flow to supply condenser water to Richardson Hall chiller CH-1. The pump circulates water between the Richardson Hall chiller CH-1 and the condenser water loop in the basement of Peavy Hall. Refer to “Peavy Hall Condenser Water System” for additional information related to the condenser water system configuration and operation. The pump includes the following characteristics and design performance:

- Model: TACO FE
- Flow: 1000 gpm
- Head: 50 ft
- Motor Horsepower: 30 hp

The primary pump operates whenever the chiller is on.

Pump Redundancy: There is one primary pump. If that unit is not operable, then the building will not have cooling.

Emergency Refrigerant Exhaust System

An emergency refrigerant detection system has been provided for the Richardson Hall chilled water plant. The detection system includes a MSA Model Chillgard LE refrigerant monitor. The monitor will automatically stop the chillers, operate emergency ventilation exhaust fan EF-13, and open outside air dampers for make-up air when a refrigerant leak is detected. The fan includes the following characteristics and design performance:

- Model: Greenheck Model BSQ-140-5
- Flow: 1,800 cfm
- Pressure: 0.5 inches w.c.

Notable Conditions:

- Chiller CH-1 was installed in 2004 and is approaching the expected service life of 23 years as suggested by ASHRAE Standards.
- Chilled water and condenser water pumps were installed in 1997 and have exceeded the expected service life of 20 years as suggested by ASHRAE Standards.
- Chiller CH-1 evaporator tube bundles needs regular maintenance to clean out scaling and sediment caused by corrosion. Chiller isolation valves do not close completely so the entire chilled water system must be drained to perform this task. Refilling the chilled water system with city water adds to the corrosion issues in the chilled water piping.
- Chiller CH-1 is not able to operate reliably at low load conditions. To remedy this condition, automatic control sequences have been added to preheat incoming outside air at air handling units AHU-1 and AHU-2 to ensure that a base load is maintained that will enable the chiller to operate reliably. Preheating outside air increases energy consumption and provides no benefit to the building other than to keep the chiller operational. Additionally, preheating outside air adds load to the air handling unit cooling coil, which can result in the coil being unable to maintain the desired supply air temperature. This may contribute to the general overheating in laboratory and administration spaces as reported by OSU research staff.
- Chiller CH-1 relief vent piping discharges approximately 7' above grade in the landscaped area to the east of the building. The point of discharge is near doors and intake air louvers to the chiller room. OSMC 1105.7 requires pressure relief devices to terminate outdoors not less than 15 feet above adjoining grade level and not less than 20' from an opening or exit.
- The intertie pump CHP-3 is no longer in use. Underground piping between the buildings appears to have been abandoned in place.
- Emergency exhaust fan discharges to the east of the chiller room approximately 7' above grade. OSMC 1105.6.1 requires 20' distance between exhaust and openings into the building.
- The refrigerant monitor appears to be of recent vintage and is in good operating condition.
- The chilled water system has no equipment redundancy to enable operation if any individual equipment component is not operational due to maintenance shutdown or failure.

- The building chilled water system is not reliable. The system is unable to maintain continuous operation during the cooling season and numerous extended system outages have occurred in the past year.

Richardson Hall Insect-Rearing Laboratory Chilled Water System

The chilled water system serving the insect-rearing containment laboratory and greenhouse is configured in a primary-only arrangement and provides chilled water to air handling units AHU-4 and AHU-5. Chilled water is provided by an air-cooled chiller CH-2 on the roof. The system has a cooling capacity of 20 tons with a maximum flow of 32 gpm. The chiller has a connected cooling load of 20 tons with a design flow of 32 gpm. The system circulates a glycol/water mixture to prevent freezing of the hydronic fluid.

A schematic of the insect rearing laboratory chilled water system is shown in Figure 1 below. The chilled water plant has the following major elements:

- Chillers
- Primary chiller pumps

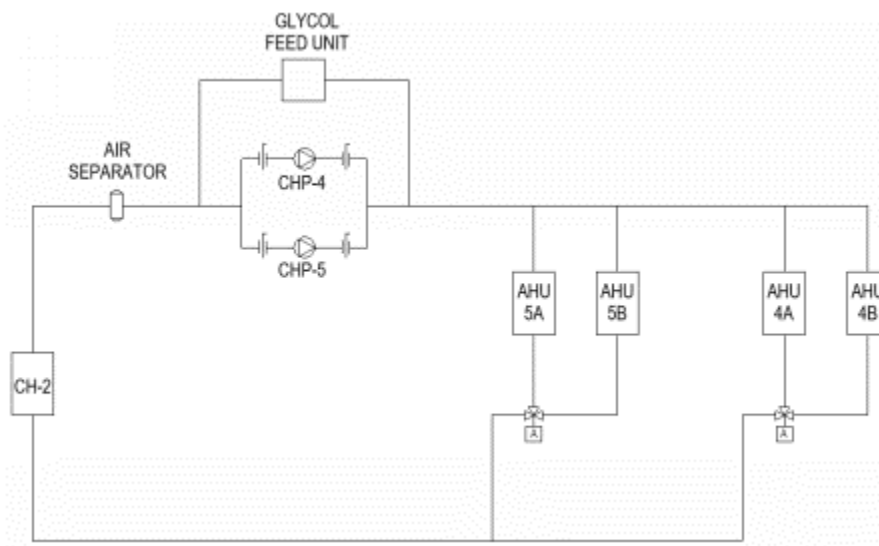

Figure 2 Richardson Hall Insect Rearing Chilled Water Diagram

Chiller

Chiller CH-2 is a York Model WIL air-cooled chiller designed to cool 32.5 gpm of water and glycol solution from 52°F to 39°F. The chiller is in a primary only configuration with primary pumps circulating a constant volume of water through the chiller to the rooftop air handling units. The chilled water in this system contains a glycol mixture to prevent freezing.

The chiller has the following characteristics and design performance:

- Model: York Model WIL
- Capacity: 20 tons
- Compressor Type: Scroll
- Chilled Water Flow: 32.5 gpm

- Chilled Water Temperatures: 52°F in, 39°F out

Chiller Redundancy: The system has no redundant cooling equipment. There is one chiller and if that unit is not operable then the system will not have cooling.

Primary Pumps

Primary pumps CHP-4 and CHP-5 operate in a lead/lag sequence and provide a constant flow of water through chiller CH-2. The pumps are identical and have the following characteristics and design performance:

- Flow: 32.5 gpm
- Head: 28 ft
- Motor Horsepower: 3/4 hp

The lead primary pump operates whenever the chiller is on.

Pump Redundancy: The two chilled water pumps are fully redundant, and the system can operate normally if one pump is not operable.

Notable Conditions:

- Chiller CH-2 was installed in 1997 and has exceeded the expected service life of 20 years as suggested by ASHRAE Standards.
- Chilled water pumps were installed in 1997 and have exceeded the expected service life of 20 years as suggested by ASHRAE Standards.
- Chiller CH-2 is currently providing 44°F to air handling units AHU-4 and AHU-5 cooling coils instead of 39°F as originally designed.

Peavy Hall Chilled Water System

Peavy Hall was replaced in 2017. Peavy Hall is physically connected to Richardson Hall; however, MEP systems are substantially independent of each other. The one notable exception is the condenser water system that provides heat rejection for chiller CH-1 in Richardson Hall and chiller HP-B01 in Peavy Hall. A description of the chilled water and condenser water system in Peavy Hall is included here to provide context for understanding the integrated condenser water system and chilled water system reliability for both Richardson Hall and Peavy Hall.

The chilled water system in Peavy Hall is configured in a primary-only arrangement and provides chilled water to a cooling coil and an exhaust air heat recovery coil in air handling unit AHU-B01. The system also provides 53°F chilled water to radiant cooling floors and fan coil units. The system has a cooling capacity of 215 tons with a maximum secondary flow of 430 gpm.

A schematic of the chilled water system is shown in Figure 3 below. The building chilled water plant has the following major elements:

- Modular heat pump chiller
- Primary chilled water pumps
- Sensible chilled water pumps

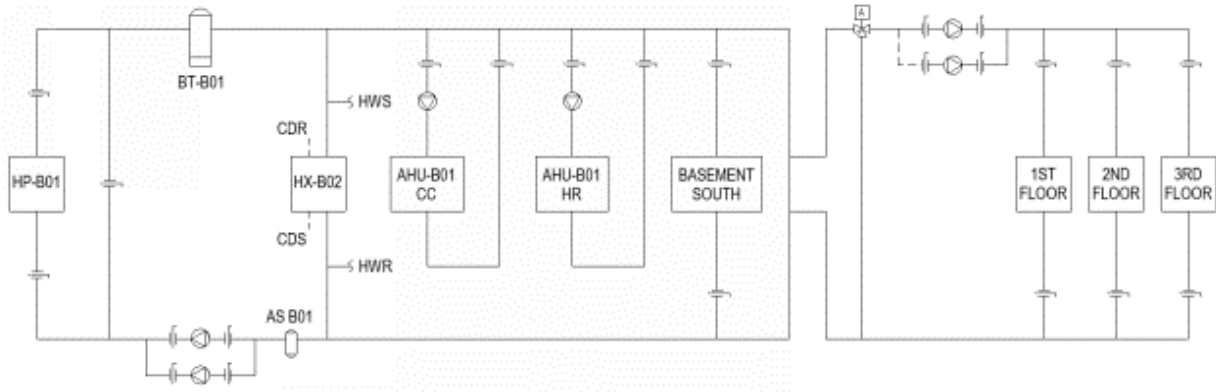

Figure 3 Peavy Hall Chilled Water Diagram

A schematic of the chilled water system is shown in Figure 3 above. The building chilled water plant has the following major elements:

- Modular heat pump chiller
- Primary chilled water pumps
- Sensible chilled water pumps

Modular Heat Pump Chiller

Chilled water for building cooling is provided by a modular water-cooled heat pump chiller HP-B01 located in basement mechanical room. The chiller has the following characteristics and design performance:

- Model: Multistack MS050
- Capacity: 215 tons
- Modules 4
- Compressor Type: Scroll
- Chilled Water Flow: 322 gpm
- Chilled Water Temperatures: 60°F in, 44°F out
- Condenser Water Flow: 440 gpm
- Chilled Water Temperatures: 77°F in, 91°F out

Chiller Redundancy: The chiller is a modular unit with four independent capacity elements each provided with an independent power connection. The chiller will continue to operate if any module fails. This chiller has one primary unit controller. If the unit controller fails or utility power is interrupted the chiller will be inoperable.

Primary Pumps

Primary pumps CHP-B01 and CHP-B02 operate in a lead/lag sequence and provide a variable flow of water through chiller HP-B01. The pumps are identical and have the following characteristics and design performance:

- Flow: 220 gpm
- Head: 60 ft
- Motor Horsepower: 5 hp

The lead primary pump operates whenever the chiller is on, and the lag pump operates as required to meet load. Pumps modulate to maintain a constant pressure differential between the chiller inlet and outlet connections.

Pump Redundancy: The two chilled water pumps are not fully redundant. Each pump can provide 70% of the chiller design flow. The system will remain operable if one pump fails, but at a reduced capacity.

Sensible Chilled Water Loop and Pumps

A sensible chilled-water cooling loop provides 53°F water to radiant cooling floors and selected fan coil units. Primary pumps CHP-B03 and CHP-B04 operate in a lead/lag sequence and provide a variable flow of water to connected equipment. The pumps are identical and have the following characteristics and design performance:

| | |
|-------------------|-----------|
| Flow: | 1,100 gpm |
| Head: | 50 ft |
| Motor Horsepower: | 3 hp |

The lead primary pump operates whenever the chiller is on, and the lag pump operates as required to meet load. Pumps modulate to maintain a constant pressure differential between supply and return piping.

Pump Redundancy: The two chilled water pumps appear to be fully redundant. Cooling will be provided to sensible cooling systems if one pump fails.

Condenser System Heat Recovery Heat Exchanger

The condenser water system can be used to add cooling load to the chilled water system during the heating season to increase heating output of the HP-B01 to meet space heating loads. Heat exchanger HX-B02 is used, in this mode of operation, to heat chilled water using energy contained in the condenser water system. The heat exchanger has the following characteristics and design performance in the heat recovery mode:

| | |
|-------------------------------|-------------------|
| ▪ Type: | Plate and frame |
| ▪ Cooling Capacity: | 181 tons |
| ▪ Chilled Water Flow: | 272 gpm |
| ▪ Chilled Water Temperatures: | 60°F in, 44°F out |

Heat exchanger HX-B02 is also connected to the heating water system to provide heat rejection when the chiller is producing more heat output than is required to heat the Peavy Hall. Automatic switchover valves determine if chilled water or heating water flow through the HX-B02. The heat exchanger has the following design performance in the heat rejection mode:

| | |
|-------------------------------|-------------------|
| ▪ Heating Capacity: | 3,080 mbh |
| ▪ Heating Water Flow: | 440 gpm |
| ▪ Heating Water Temperatures: | 91°F in, 77°F out |

Notable Conditions:

- The chiller appears to be in good condition and is generally operating as intended.

- Frequent unit alarms occur that trip individual compressors. The alarms are thought to be due to fluctuations in power quality. OSU staff report that one compressor often trips on alarm.

Peavy Hall Condenser Water System

The condenser water system in Peavy Hall is configured in a primary-secondary arrangement and provides heat rejection for chiller CH-1 in Richardson Hall and for Peavy Hall using heat exchanger HX-B02. The system has a total heat rejection capacity of 10.2 million btu/hr with a maximum primary flow of 1570 gpm. The system total connect load is 10.1 million btu/hr tons with a design flow of 1,510 gpm.

A schematic of the Peavy Hall condenser water system is shown in Figure 4 below. The condenser water system has the following major elements:

- Cooling towers
- Primary condenser water pumps
- Secondary condenser water pumps
- Peavy Hall heat rejection/heat recovery heat exchanger
- Side stream water filter

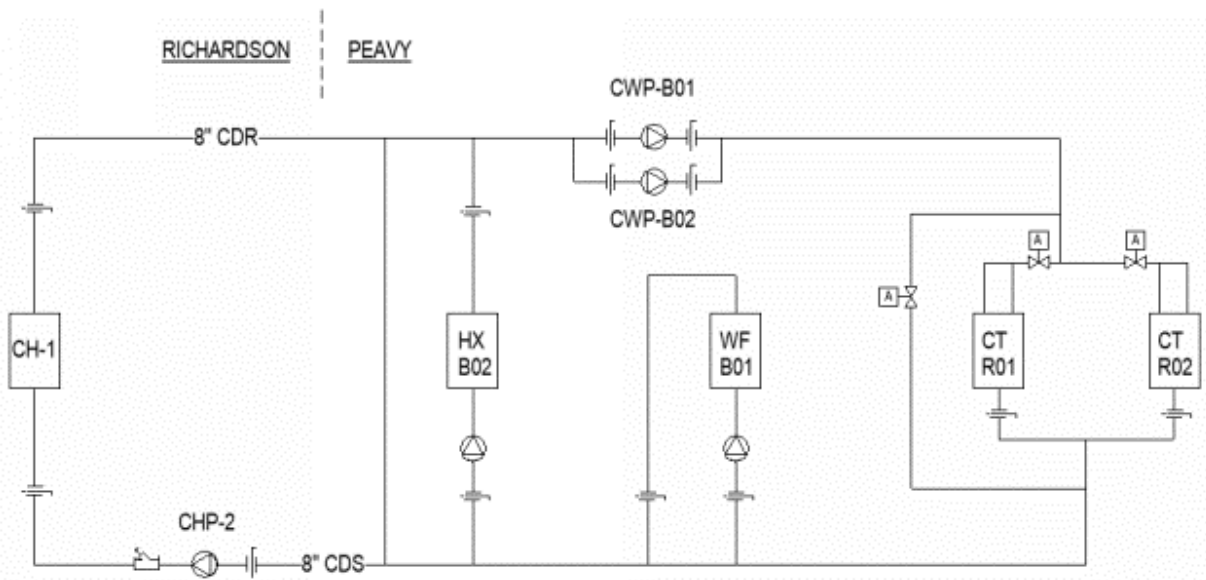

Figure 4 Richardson/Peavy Hall Condenser Water Diagram

Cooling Towers

Two crossflow induced draft cooling towers CT-R01 and CT-R02 provide heat rejection and heat recovery. The cooling towers are identical and have the following characteristics and design performance:

- Model: Marley NC
- Heat Rejection Capacity: 5.1 million btu/hr
- Condenser Water Flow: 785 gpm

- Condenser Water Temperatures: 89°F in, 76°F out

Cooling Tower Redundancy: The two cooling towers are not fully redundant. Each tower can provide 50% of heat rejection required for the connected load. System will remain operable if one tower fails, but at about 50% of design capacity.

Primary Condenser Water Pumps

Primary pump CWP-B03 operates at a variable flow, circulating water through heat exchanger HX-B02 to maintain the supply temperature setpoint. The pump has the following characteristics and design performance:

- Model: Bell & Gossett 1510
- Flow: 475 gpm
- Head: 15 ft
- Motor Horsepower: 3 hp

The primary pump operates whenever either secondary pump is on.

Pump Redundancy: There is one primary pump serving HX-B02. If that unit is not operable then the building will not have cooling capacity other than that generated by the heat pump heating process, which would provide little benefit to the building during the summer cooling season.

Secondary Condenser Water Pumps

Secondary condenser water pumps CWP-B01 and CWP-B02 operate at a variable flow to circulate condenser water to heat rejection equipment. The pumps are identical and have the following characteristics and design performance:

- Model: Bell & Gossett 1510
- Flow: 830 gpm
- Head: 50 ft
- Motor Horsepower: 15 hp

The lead secondary pump operates whenever the lead cooling tower is on, and the lag pump operates when the lag cooling tower is on. Pumps modulate to maintain the differential pressure setpoint across the heat pump.

Pump Redundancy: The two pumps are not fully redundant. Each pump can provide flow for one cooling tower. The system will remain operable if one pump fails, but at a reduced capacity.

Notable Conditions:

- The cooling towers CT-R01 and CT-R02 were installed in 2018 and appear to be in good condition and generally operating as intended.
- Condenser water pumps CWP-B01, CWP-B02, and CWP-B03 were installed in 2018 and appear to be in good operating condition.

Air Distribution Systems

Richardson Hall is divided into three main building sections:

- Administration Wing
- Laboratory Wing
- High Bay and Kiln sections

The administration area consists of offices, conference rooms, and classrooms. The laboratory area is composed of multiple laboratory spaces, laboratory offices, and a biosafety level 3 insect rearing laboratory and greenhouse. The high bay and kiln areas are used for wood lamination and preserving technique research. Following is a description of air distribution systems serving each section.

Administration Wing

The administration wing is served by air handling unit AHU-2. The air handling unit is located in a penthouse on the roof of the administration wing and includes a return fan, exhaust outlet, outside air intake, filter section, heating coil, cooling coil, and supply fan. The air handling unit supplies air to terminal units on the first through third floors. Terminal units are variable volume with hydronic heating coils. Air is returned to the air handling unit through a return air plenum on each floor. Air handling unit AHU-2 has the following characteristics and design performance:

- Manufacturer: Pace
- Supply Fan:
 - Airflow: 36,165-cfm
 - Static Pressure 5-inches
 - Motor Horsepower 75-hp
- Return Fan
 - Airflow: 36,165-cfm
 - Static Pressure 2-inches
 - Motor Horsepower 25-hp
- Outside Airflow (min.) 7,235-cfm
- Heating Coil
 - Capacity 279-MBH
 - Entering Air Temperature 46°F
 - Leaving Air Temperature 53°F
 - Air pressure drop 0.4-inches
 - Entering Water Temperature 180 °F
 - Flow 14-gpm
 - Water Pressure Drop 5-feet
- Cooling Coil
 - Total Capacity 1284-MBH
 - Sensible Capacity 1174-MBH

- Entering Dry Bulb Air Temperature 81.4°F
- Entering Wet Bulb Air Temperature 64°F
- Leaving Air Dry Bulb Temperature 52°F
- Leaving Air Wet Bulb Temperature 51.7°F
- Air Pressure Drop 0.5-inches
- Entering Water Temperature 44°F
- Flow 171-gpm
- Water Pressure Drop 10-feet

Air handling unit AHU-2 operates during occupied academic hours and is off during unoccupied hours.

Stair Well Exhaust

Exhaust fan EF-9 is a rooftop down blast fan on the roof of the administration wing. It serves the stairwell in the administration wing. Exhaust fan EF-9 has the following characteristics and design performance:

- Manufacturer and Model: Greenheck GB
- Airflow: 4,000-cfm
- Static Pressure 0.25-inches
- Motor Horsepower 0.75-hp

Notable Conditions:

- Air handling units and exhaust fans were installed in 1999 and according to ASHRAE are near the end of their service life expectancy of 25 years.
- OSU staff noted that air handling unit AHU-2 did not appear to have sufficient cooling capacity.
- Chilled water and heating water control valves at the air handling units have pneumatic actuators that are unreliable due to leaks in the system.
- Spaces along the south exterior wall are reportedly too warm in summer.
- All exterior spaces are reportedly too cold in winter. It was noted that both supply and return air diffusers are installed in the ceiling.
- It appears that warm air supplied to the space may be traveling directly to the return grille without heating the spaces.

Laboratory Wing

The laboratory wing is served by air handling units AHU-1, AHU-3, AHU-4, and AHU-5, and multiple general and laboratory exhaust fans:

Laboratory Supply Unit AHU-1

Air handling unit AHU-1 provides 100% outside air to laboratory spaces. The air handling unit includes two independent air tunnels identified as A and B, each sized for 50% of the total supply air requirement of laboratory spaces. Each air handling section includes an outside air

intake, pre-filter, final filter, heat recovery coil, heating coil, cooling coil, and supply fan. The air handling unit supplies 100% outside air to the first through third floors. Laboratory airflow and space pressure are controlled by pressure independent laboratory air valves. The air valves include both variable and constant volume types and are designed to maintain the required pressure differential between laboratory spaces. There is a hydronic heating coil downstream of each supply air valve. Air handling unit AHU-1 has the following characteristics and design performance:

- Manufacturer: Pace
- Supply Fan SF-1:
 - Airflow: 37,500-cfm
 - Static Pressure 5-inches
 - Motor Horsepower 60-hp
- Supply Fan SF-2:
 - Airflow: 37,500-cfm
 - Static Pressure 5-inches
 - Motor Horsepower 60-hp
- Heat Recovery Coil (Typical for each section)
 - Capacity 947-MBH
 - Entering Air Temperature 10°F
 - Leaving Air Temperature 33.4°F
 - Air pressure drop 0.37-inches
 - Entering Water Temperature 45°F
 - Flow 92-gpm
 - Water Pressure Drop 19-feet
- Heating Coil (Typical for each section)
 - Capacity 1856.3-MBH
 - Entering Air Temperature 10°F
 - Leaving Air Temperature 55°F
 - Air pressure drop 0.5-inches
 - Entering Water Temperature 180°F
 - Flow 92.8-gpm
 - Water Pressure Drop 5-feet
- Cooling Coil (Typical for each section)
 - Total Capacity 1569.4-MBH
 - Sensible Capacity 1417.5-MBH
 - Entering Dry Bulb Air Temperature 89°F

- Entering Wet Bulb Air Temperature 67°F
- Leaving Air Dry Bulb Temperature 54°F
- Leaving Air Wet Bulb Temperature 53.5°F
- Air Pressure Drop 0.5-inches
- Entering Water Temperature 44°F
- Flow 300-gpm
- Water Pressure Drop 10-feet

Both Sections of air handling unit AHU-1 operate continuously. The fans modulate to maintain a constant supply duct static pressure.

Air Handler Unit AHU-1 Redundancy: The two air handler sections are not fully redundant. Each section can provide 50% of the laboratory maximum airflow.

Notable Conditions:

- Air handling units were installed in 1999 and have exceeded the expected service life of 25 years as suggested by ASHRAE Standards.
- Air handling unit AHU-1 has water inside many of the fan compartments. It is unclear where the water is entering the unit. Given the amount and location of the water, it is likely that the source is the outside air intake. It is more probable that the water is entering from casing leaks or through door seals. A significant amount of corrosion is occurring on the floors, casing, filter frames, and coil frames. Efforts have been made to coat the unit floor to prevent corrosion. This seems to have provided some benefit, but the water intrusion continues.



Photo 1: AHU-1 Outside Air Intake Plenum



Photo 2: AHU-1 Filter Plenum



Photo 3: AHU-1 Heat Recovery Coil Plenum



Photo 4: AHU-1 Heating Coil Plenum

- The run-around heat recovery system has been shut down due to loss of hydronic fluid from the piping system. No leaks were identified in the pipe, and OSU Facilities staff believe fluid loss is due to the temperature and pressure relief valve discharging resulting from pressure fluctuations.
- Laboratory spaces are reportedly too hot in most locations for a majority of the year. Unreliable operation of the chilled water system has significantly contributed to this issue. However, issues with the AHU-1 heat recovery systems, operation of laboratory air valves, and DDC controls affect space temperature control.
- During a recent period, there were high temperature complaints on the third floor due to failed zone reheat valves. When the system was false loaded by running hot water in the summer, some of the reheat coil valves did not shut, and rooms got too warm. This was

significantly improved by isolating hot water to the floor indicating that some reheat coil valves have failed open.

- Supply diffusers in laboratories are linear slot type. These diffusers discharge air at relatively high velocity and create undesirable air currents. Some diffusers have covers to redirect airflow. The slot diffusers may be short circuiting into the exhaust inlet in some locations.



Photo 5: Linear Slot Diffusers in Laboratories

- Some spaces have insufficient airflow to meet the cooling load for laboratory equipment contained in the rooms. Large heat loads in Incubator Room 379 and Ultra-low Freezer and Growth Chamber 386 rooms are two specific locations.
- Ceilings in Greenhouse/Control Enviro Lab 389 are discolored near supply diffusers. This could be caused by ambient air being entrained into the supply air stream at the diffuser or could indicate that filtration systems are not performing as intended.
- Greenhouse-1 389A and Greenhouse-2 389B rooms appear to be naturally ventilated. The greenhouse space temperature reportedly exceeds the desired temperature required for research during portions of the summer

Laboratory Office Air Handler AHU-3

Air handling unit AHU-3 serves the laboratory offices along the west side of the laboratory wing. Air handler AHU-3 includes a return fan, exhaust outlet, outside air intake, filter section, cooling coil, and supply fan. The air handler supplies air to terminal units on the first through third floor. Terminal units are variable volume with hydronic reheat coils. Return air is ducted back to the air handling unit.

Air handling Unit AHU-3 operates continuously.

Air handling unit AHU-3 has the following characteristics and design performance:

- Manufacturer: Pace
- Supply Fan:
 - Airflow: 19,420-cfm
 - Static Pressure 5-inches
 - Motor Horsepower 40-hp
- Return Fan
 - Airflow: 18,780-cfm
 - Static Pressure 1.5-inches
 - Motor Horsepower 10-hp
- Outside Airflow (min.) 1480-cfm
- Cooling Coil
 - Total Capacity 537.5-MBH
 - Sensible Capacity 510-MBH
 - Entering Dry Bulb Air Temperature 78.5°F
 - Entering Wet Bulb Air Temperature 63.1°F
 - Leaving Air Dry Bulb Temperature 54.6°F
 - Leaving Air Wet Bulb Temperature 53.6°F
 - Air pressure drop 0.5-inches
 - Entering Water Temperature 44°F

- Flow 72-gpm
- Water pressure drop 10-feet

Notable Conditions:

- The air handling unit was installed in 1999 and has exceeded the expected service life of 25 years as suggested by ASHRAE Standards.
- Offices spaces in the laboratory wing are reportedly too hot during summer months, and this appears to be due to insufficient cooling capacity.
- Multiple offices are combined into common temperature control zone. Additionally, offices have operable windows. Space temperatures are often not uniform for all spaces in a common temperature zone.

Insect Rearing and Greenhouse 3 Air Handlers AHU-4 and AHU-5

The insect rearing laboratory and associated greenhouse were originally designed as an ABSL-3Ag containment facility certified by the USDA Animal and Plant Health Inspection Service (APHIS) intended for research of non-native arthropods that pose a risk to the environment. Testing and certification were completed in 2005. The facility operated under USDA certification until the autoclave serving the facility failed in about 2017. The suite is currently used for research that does not require ABSL-3Ag containment. It is unclear if the University intends to recertify the facility in the future.

The suite is located on the south end of the third floor and is served by two air handlers. AHU-4 serves Greenhouse 389C room and AHU-5 serves the Insect Rearing Lab 387. Following is a description of these systems.

Greenhouse Air Handler AHU-4: AHU-4 serves Greenhouse #3 and consists of two fully redundant air tunnels each sized for 100% of the design airflow. Each air handling section includes an outside air and return air inlet, prefilter, heating coil, cooling coil, supply fan, and final HEPA filter. Additionally, HEPA filters are installed at each return air inlet. The chilled water coil is served from Insect Rearing chilled water system. Supply air is delivered to the space through air valves that modulate the air to maintain pressure differentials between spaces. Return air is ducted from the greenhouse back to AHU-4.

The air handling unit has the following characteristics and design performance:

- Manufacturer: Pace
- Supply Fan SF-1: (typical for both fan sections)
 - Airflow: 3,000-cfm
 - Static Pressure 4-inches
 - Motor Horsepower 5-hp
- Outside Airflow (min.) 200-cfm
- Heating Coil (Typical for each section)
 - Capacity 297-MBH
 - Entering Air Temperature 50°F
 - Leaving Air Temperature 140°F
 - Air pressure drop 0.3-inches

- Entering Water Temperature 180°F
- Flow 14.9-gpm
- Water pressure drop 5-feet
- Cooling Coil (Typical for each section)
 - Total Capacity 131.1-MBH
 - Sensible Capacity 72.7-MBH
 - Entering Dry Bulb Air Temperature 80°F
 - Entering Wet Bulb Air Temperature 70°F
 - Leaving Air Dry Bulb Temperature 57.8°F
 - Leaving Air Wet Bulb Temperature 56.7°F
 - Air pressure drop 0.5-inches
 - Entering Water Temperature 39°F
 - Flow 18.6-gpm
 - Water pressure drop 10-feet

AHU-4 Exhaust Fan: Exhaust fans EF-17 and EF-18 are utility type fans located on the roof of the laboratory wing. Each exhaust fan is ducted to a HEPA filter before connecting to a common duct that connects to the return duct from AHU-4. The fan exhausts an amount equal to the outside air ventilation provided to the spaces served. The exhaust duct includes a laboratory air valve to maintain room pressure in the greenhouse. The exhaust fans are sized for 100% redundant operation.

Exhaust fans have the following characteristics and design performance:

- Manufacturer and Model (typical both fans): Barry Blower Industracon 61-OT
- Airflow: 200-cfm
- Static Pressure 3.5-inches
- Motor Horsepower 0.5-hp

Insect Rearing Air Handler AHU-5: AHU-5 consists of two fully redundant air tunnels each sized for 100% of the design airflow. Each air handling section includes an outside air prefilter, heating coil, cooling coil, supply fan, and final HEPA filter. The chilled water coil is served from Insect Rearing chilled water system. Supply air is delivered to the space through air valves that modulate the air to maintain pressure differentials between spaces. A duct-mounted humidifier H-2 maintains minimum space relative humidity in the insect rearing lab.

The air handling unit has the following characteristics and design performance.

- Manufacturer: Pace
- Supply Fan SF-1: (typical for both fan sections)
 - Airflow: 2,550-cfm
 - Static Pressure 4-inches
 - Motor Horsepower 5-hp

- Heating Coil (Typical for each section)
 - Capacity 364.7-MBH
 - Entering Air Temperature 10°F
 - Leaving Air Temperature 140°F
 - Air pressure drop 0.3-inches
 - Entering Water Temperature 180F
 - Flow 18.2-gpm
 - Water pressure drop 5-feet
- Cooling Coil (Typical for each section)
 - Total Capacity 100.1-MBH
 - Sensible Capacity 97.8-MBH
 - Entering Dry Bulb Air Temperature 89°F
 - Entering Wet Bulb Air Temperature 67°F
 - Leaving Air Dry Bulb Temperature 53.5°F
 - Leaving Air Wet Bulb Temperature 52°F
 - Air pressure drop 0.5-inches
 - Entering Water Temperature 39°F
 - Flow 13.9-gpm
 - Water pressure drop 10-feet

AHU-5 Exhaust Fan: EF-2 and EF-3 are utility type fans located on the roof of the laboratory wing. Each exhaust fan is ducted to a HEPA filter before connecting to a common duct that connects to the common exhaust duct from the lab suite. The fan exhausts air from exhaust air grilles and the autoclave canopy hoods. The exhaust duct includes a laboratory air valve to maintain room pressure in the greenhouse. The exhaust fans are sized for 100% redundant operation.

Exhaust fans have the following characteristics and design performance:

- Manufacturer and Model (typical both fans): Greenheck SWB-15-30
- Airflow: 2,550-cfm
- Static Pressure 3.5-inches
- Motor Horsepower 3-hp

Notable Conditions:

- Air handling units and most exhaust fans were installed in 1999 and have exceeded the expected service life of 25 years as suggested by ASHRAE Standards.
- Staff report that the space pressure in the insect rearing laboratory is excessively negative.
- The greenhouse space temperature reportedly exceeds the desire temperature required for research during portions of the summer.

Laboratory Exhaust Unit EF-1

Exhaust unit EF-1 provides laboratory exhaust for research spaces in the laboratory wing. The rooftop exhaust unit includes an exhaust air plenum with heat recovery coil and modulating face and bypass dampers, five high plume exhaust fans, and two bypass pressure control dampers. Each exhaust fan is designed to provide one-quarter of the design exhaust airflow rate. One fan functions as a standby unit. The exhaust is ducted from the exhaust unit to laboratory air valves on the first through third floor of the laboratory wing.

Four of the five exhaust fans operate continuously at a constant exhaust airflow rate. If one fan fails, then the standby fan operates. The two bypass dampers modulate to introduce outside air into the exhaust fan inlet plenum to maintain a constant exhaust duct static pressure setpoint. Laboratory exhaust airflow is variable volume. Outside air is added to the exhaust fan inlet plenum to maintain a constant total fan airflow rate.

The exhaust unit has a heat recovery section, which includes a heat recovery coil, face and bypass damper, bypass air pathway, and an isolation damper downstream of the heat recovery coil. The isolation dampers can be shut to isolate the heat recovery coil for maintenance access. Heat recovery fluid is circulated between the heat recovery coil in the heat exhaust air plenum and preheat coils in both sections of AHU-1. A heat recovery pump is included inside of air handling unit AHU-1. The heat recovery fluid is a water and glycol mixture to prevent it from freezing.

Exhaust fan EF-1 has the following characteristics and design performance:

| | |
|------------------------------|-------------------|
| ▪ Manufacturer and Model: | Strobic Tri Stack |
| ▪ Airflow: (per fan) | 18,750-cfm |
| ▪ Static Pressure | 5-inches |
| ▪ Motor Horsepower (per fan) | 30-hp |

Exhaust fan EF-1 operates continuously. Bypass dampers modulate to maintain exhaust duct static pressure.

Exhaust Fan Redundancy: Each of the five exhaust fans are sized for 25% of the maximum exhaust airflow. If one exhaust fan fails, the system can still maintain design exhaust airflow.

Exhaust Fan Maintenance: The exhaust unit has a heat recovery section, which includes a heat recovery coil, face and bypass dampers, and an isolation damper downstream of the heat recovery coil. The face and bypass dampers and isolation dampers can be shut to isolate the heat recovery coil for maintenance access.

Notable Conditions:

- Air handling units and most exhaust fans were installed in 1999 and have exceeded the expected service life of 25 years as suggested by ASHRAE Standards.
- Exhaust fan EF-1D is not operational. The unit currently has no standby capacity if another exhaust fan fails.
- EF-1 exhaust fan isolation dampers are reportedly in poor condition and are unreliable. Some do not function.
- EF-1 unit housing and equipment components are showing signs of rust and corrosion.



Photo 6: Exhaust Fan EF-1

- The EF-1 heat recovery coils do not appear to have air filters upstream to protect the coil from fouling. No filters are shown on the as-built plans upstream of the heat recovery coil in the exhaust plenum. No filter access doors were observed on the unit casing.

Laboratory Process Exhaust Fans

Exhaust for critical laboratory functions is provided by individual utility type exhaust fans located on the roof of the laboratory wing:

Radioscope Hood Exhaust: Exhaust fans EF-5 and EF-6 serve two separate lab hoods in the radioscope room located on the third floor of the laboratory wing. The two exhaust fans operate continuously. Both exhaust fans have the following characteristics and design performance:

- | | |
|-----------------------------------|-------------------------------|
| ▪ Manufacturer and Model: | Barry Blower IND. Series 9-61 |
| ▪ Airflow: | 900-cfm |
| ▪ Static Pressure | 3.25-inches |
| ▪ Motor Horsepower (Typical of 5) | 1-hp |

Hazardous Storage Room Exhaust: Exhaust fan EF-11 is an explosion-proof utility exhaust fan located on the roof of the laboratory wing. It is ducted to high and low exhaust inlets in the

first-floor hazardous material storage room. The fan operates continuously. The exhaust fan has the following characteristics and design performance:

- Manufacturer and Model: Barry Blower IND. Series 7-61
- Airflow: 350-cfm
- Static Pressure 1-inches
- Motor Horsepower (Typical of 5) 0.25-hp

Notable Conditions:

- Most exhaust fans were installed in 1999 and have exceeded the expected service life of 25 years as suggested by ASHRAE Standards.
- Exhaust fans EF-5, EF-6, and EF-11 are in poor condition and have significant signs of corrosion.
- Exhaust fans EF-5, EF-6, and EF-11 are lightweight fans installed directly on spring isolators. The mounting springs do not have sufficient strength to maintain a consistent mounting position causing excessive stress on fan frames.

General Exhaust Fans

Stair Well Exhaust: Exhaust fan EF-10 is a rooftop down blast ventilator located on the roof of the laboratory wing. It serves the stairwell south of the laboratory offices. Exhaust fan EF-10 has the following characteristics and design performance:

- Manufacturer and Model: Greenheck GB
- Airflow: 4,000-cfm
- Static Pressure 0.25-inches
- Motor Horsepower 0.75-hp

Basement General Exhaust: EF-12 is an inline exhaust fan in the basement wet room. It also serves the basement toilet room. Exhaust fan EF-12 has the following characteristics and design performance:

- Manufacturer and Model: Greenheck BSQ-120-5
- Airflow: 1,300-cfm
- Static Pressure 0.5-inches
- Motor Horsepower 0.5-hp

Chiller Room Exhaust: EF-13 is an inline exhaust fan in the basement chiller room. It serves the chiller room as general and emergency exhaust. Exhaust fan EF-13 has the following characteristics and design performance:

- Manufacturer and Model: Greenheck BSQ-140-5
- Airflow: 1,800-cfm
- Static Pressure 0.5-inches
- Motor Horsepower 0.5-hp

Basement Room 006: EF-14 is an inline exhaust fan in the basement wet mechanical room. It serves as general exhaust for wet room ventilation. Exhaust fan EF-14 has the following characteristics and design performance:

- Manufacturer and Model: Greenheck BSQ-180-7
- Airflow: 3,000-cfm
- Static Pressure 0.5-inches
- Motor Horsepower 0.75-h

High Bay and Kiln

The high bay and kiln areas are served by heating and ventilating units HV -1 and HV-2. HV-1 serves the kiln area, and HV-2 serves the high bay. Each unit includes a mixing box, filter section, hot water heating coil, and supply fan. The units have the following characteristics and design performance:

- Manufacturer: York
- Supply Fan: (typical for both HV-1 and HV-2)
 - Airflow: 8,700-cfm
 - Static Pressure 4-inches
 - Motor Horsepower 5-hp
- Outside Air HV-1: 300-cfm
- Outside Air HV-2: 340-cfm
- Heating Coil HV-1
 - Capacity 137.8-MBH
 - Entering Air Temperature 65.8°F
 - Leaving Air Temperature 80.2°F
 - Air pressure drop 0.25-inches
 - Entering Water Temperature 180°F
 - Flow 6.9-gpm
 - Water pressure drop 5-feet
- Heating Coil HV-2
 - Capacity 270-MBH
 - Entering Air Temperature 87°F
 - Leaving Air Temperature 115.6°F
 - Air pressure drop 0.25-inches
 - Entering Water Temperature 180°F
- Flow 13.5-gpm
- Water pressure drop 5-feet

Exhaust fan EF-7 is an inline exhaust fan in room 197B. It serves as general exhaust to the kiln room and room 197B. Exhaust fan EF-7 has the following characteristics and design performance:

- Manufacturer and Model: Greenheck BSQ-300-30
- Airflow: 10,000-cfm
- Static Pressure 0.65-inches
- Motor Horsepower 3-hp

Exhaust fan EF-8 is a rooftop down blast fan on the roof of the high bay. It serves as general exhaust for the high bay. Exhaust fan EF-8 has the following characteristics and design performance:

- Manufacturer and Model: Greenheck BSQ-300-30
- Airflow: 8,000-cfm
- Static Pressure 0.5-inches
- Motor Horsepower 2-hp

Building Automation Systems

The building automation controls consist of a Phoenix pneumatic system for lab airflow controls and a Siemens MBC DDC system for the heating, cooling, ventilation, and plumbing controls.

Siemens DDC System

The Siemens DDC system consists of seven MBC controllers and many TECs for terminal units, reheat coils, fan coil units, etc. There are several pneumatic valve and damper actuators that are controlled by the Siemens system including:

- Lab Exhaust System (EF-1A, EF-1B, EF-1C, EF-1D, EF-1E)
 - Exhaust fan damper actuators
 - Lab exhaust heat recovery coil bypass damper actuator
- Lab Supply System (SF-1 and SF-2)
 - Outside air damper actuators
 - Smoke/isolation damper actuators
 - Heating and cooling coil control valve actuators
- Office Air Handling System (AHU-2 and AHU-3)
 - Outside air, exhaust, return, and supply air damper actuators
 - Heating and cooling coil control valve actuators
- AHU-4 and AHU-5
 - Outside air, supply, and exhaust damper actuators
 - Heating and cooling coil control valve actuators
- HVU-1 and HVU-2
 - Outside air, return, and relief damper actuators
 - Heating coil control valve actuator

- Steam service control valve actuators to the steam to hot water converter (C-1)

Phoenix Lab Control System

The Phoenix Lab control system provides air pressure control for all lab spaces through pneumatically operated air valves.

The existing fume hoods are constant volume bypass type with airflow alarms and proximity sensors. The system was designed for variable volume control and the hoods were provided with a blank-off panel behind the bypass grille to allow for variable volume control.

Systems and devices still utilizing pneumatic controls include:

- Laboratory system controllers used to control all Phoenix air valves in labs (153 qty).

Notable Conditions

- Siemens MBC controllers are obsolete, and parts are not readily available to replace failed components.
- There are no duct-mounted temperature sensors downstream of the terminal unit heating coils or duct-mounted heating coils.
- The pneumatic poly tubing is cracking and failing in multiple places.
- The current lab control system is 20+ years old and lacks reliability.
- The Siemens DDC system is 10+ years old and the TECs are unable to accommodate more points desired by the Owner, such as discharge air temperature on the terminal units and updated digital lab controls.
- Original fume hood proximity sensors are not in use. There is potential for energy savings by incorporating back in proximity sensors or sash height sensors.
- DDC control valves have been observed by the Owner to not close completely and some have been replaced.

System Evaluation

Following is a summary of our evaluation of specific HVAC system deficiencies and notable conditions identified by University staff and discovered by Systems West during our existing condition assessment. The intent of this section is to provide the necessary understanding of building conditions that inform the recommendation presented in Section 4 – Recommended Facility Improvements.

Heating, Ventilating, and Air-Conditioning

Steam Systems

Building Steam Service Pressure

The building was originally designed to receive 115 psig high-pressure steam from the OSU campus steam distribution system. The 115-psig steam was used to operate a double effect absorption chiller and for research processes. Subsequently, OSU decided to reduce distribution pressure from 115 to 60 psig.

The building steam service in the basement wet mechanical room includes two pressure reducing stations. A medium pressure reducing station reduces pressure from 115 psig to 60

psig. A low-pressure reducing station reduces pressure from 60 psig to 15 psig. The medium-pressure reducing station is no longer required since the building is being supplied with 60-psi steam. The associated pressure reducing valves, 60 psig steam safety valve, isolation valves, and strainers can be removed and replaced with a straight section of pipe to eliminate obsolete components, improve maintenance access, and reduce energy loss to the mechanical room. The low-pressure reducing station will remain to service low pressure steam loads.

Damaged steam pipe insulation throughout the mechanical room should be repaired or replaced with new insulation. Removeable jackets will be provided where they are missing. Insulation in areas subject to damage will be provided with an aluminum jacket. This will reduce energy loss from pipe and accessories.

Kiln Steam Service Pressure

Increasing the steam pressure from 60 psi to 100 psi will require increasing the campus steam system supply pressure or installing boilers to increase steam pressure for the kilns. These options are not feasible. The kilns are working with the 60-psi supply pressure. Drying times will need to be evaluated to verify if there is a problem. The faulty pressure gauge that is reading 80 psi should be replaced.

Hot Water Heating Systems

Hydronic Water Quality

The quality of hydronic fluid in the heating water system is poor. There have been reports of heating water control valves sticking open due to debris in the system. Heating water piping should be cleaned and flushed by a water treatment service provider. Cleaning and flushing the system will remove dirt, scale, microbiological fouling, and debris that have accumulated in piping and components. Once the piping has been cleaned, passivation will be performed to provide a corrosion inhibitor film on the cleaned metal surfaces.

A high-performance filter (HPF) should also be added to maintain system water quality on an ongoing basis. The filtration system will be similar to the system provided for the chilled water systems and is designed to remove particles down to 5 microns.

Heating Water Pump Upgrades

Heating water pumps HWP-1 and HWP-2 are past their expected service life and should be replaced with new heating water pumps. New pumps will require less maintenance and improve system reliability.

Chilled Water System

Richardson Hall Building Chilled Water System

The existing chilled water system has numerous deficiencies and is not functioning as intended.

Chiller Plant Configuration

The existing chilled water system is configured in a primary-secondary arrangement. This was common for older chillers that were more sensitive to changes in evaporator flow; however, this arrangement is more complex and requires twice as many chilled-water pumps.

Converting the plant to a primary-only will reduce operational complexity and improve reliability. Additionally, the intertie pump and associated piping and controls will be removed.

Water Chiller

The existing chiller has exceeded its useful life and needs replaced. The replacement needs to be sized properly for the connected loads and have the capability to operate over the entire range of load conditions encountered. The new chiller will also be significantly more efficient than the existing chiller. A replacement chiller will have the following characteristics.

- Compressor Type: Mag-lev centrifugal
- Rated Capacity: 400 tons
- Minimum Capacity: 50 tons
- Chiller Evaporator flow: 1,175 gpm
- Chilled Water Temperatures: 54°F in, 44°F out
- Condenser Water Flow: 1,100 gpm
- Chilled Water Temperatures: 76°F in, 89°F out

System Redundancy

The existing chilled water system serves critical research spaces and does not have redundant capacity units or redundant auxiliary systems. Generally, a failure of the chiller, any pump, or control system component will result in the chilled water system being inoperable. System equipment is not connected to the building standby power system. It is recommended that the plant design be upgraded to improve operating resiliency as follows:

- Provide multiple chillers. This can be accomplished in a number of ways.
 - Provide two 200-ton chillers instead of one 400-ton chiller. This option will provide 50% capacity if one chiller fails.
 - Provide one 400-ton chiller and a 100-ton heat recovery chiller. This option will provide 20% capacity if the 400-ton cooling chiller fails and significantly reduce consumption of steam from the Energy Center. This option is described in more detail in the Richardson Hall Greenhouse Gas Reduction section below.
 - Provide a chilled water interconnection to Peavy Hall. This option will provide a level of redundancy for Richardson Hall and could be designed to provide redundant cooling capacity for Peavy Hall as well. This option is described in more detail in the Peavy Hall Chilled Water System section below.
- Reconfigure the chilled water system from a primary-secondary arrangement to a primary only. The plant will be equipped with two fully redundant chilled water pumps.
- The condenser water system arrangement is generally functioning as intended; however, there is only one primary condenser water pump for the existing chiller. The plant will be equipped with two fully redundant primary condenser water pumps.
- Independent DDC controllers should be provided for each cooling unit. Redundant auxiliary equipment should also be divided between redundant controllers. Each controller should have independent input devices necessary for the system to functional normally if one controller fails.

System Maintainability

Existing facilities for maintaining the chilled water system are lacking. For example, isolation valves have failed so the entire chilled water hydronic system must be drained to clean the evaporator tubes. We recommend that the following maintenance provisions be incorporated into the new plant:

- Isolations will be provided for each equipment component so that individual units can be shutoff, isolated, and drained with remaining equipment operational.
- Isolation valves will be installed at all piping penetrations throughout the chiller room walls so the mechanical room can be isolated from the building to perform work without draining the entire system.

Hydronic Water Quality

The quality of the chilled water hydronic fluid is very poor. This is in part due to the need to frequently drain chilled water from the system to clean the evaporator tubes. Additionally, the system does not have proper filtration to remove the scale and debris that has accumulated.

The University has started the process of cleaning the chilled water system and has retained Chem-Aqua to install a bypass filtration system to remove particulate from the hydronic fluid. When the plant replacement work is performed, the systems will need to be thoroughly flushed and treated to establish desired water quality.

Richardson Hall Refrigerant Safety

Two Code deficiencies were observed during the site walk-through related to refrigerant safety:

- Chiller CH-1 pressure safety relief vent outlet piping discharges approximately 7' above grade in the landscaped area to the east of the building near the chiller room makeup air intake louver. The point of discharge is near doors and intake air louvers to the chiller room. OSMC 1105.7 requires pressure relief devices terminate outdoors not less than 15' above adjoining grade level and not less than 20' from opening or exit. The safety relief valve outlet must be relocated to confirm to Code.
- The chiller room emergency exhaust fan discharges 7' above grade near the chiller room makeup air intake louver. OSMC 1105.6.1 requires 20' of distance between exhaust and openings into the building. The exhaust outlet must be relocated to confirm to Code.

Richardson Hall Greenhouse Gas Reduction

An opportunity exists to use the building chilled water system to reduce building steam consumption and campus greenhouse gas emissions. This can be accomplished by installing a second chiller that is capable of operating with an elevated condenser temperature so that energy produced by the cooling process can be used to heat building heating water. Adding a second chiller will provide two significant benefits:

- Reduce Campus Steam Consumption: Richardson Hall is currently the fourth largest consumer of steam on the OSU campus, using about 15.5 million pounds of steam per year, which is more than 5% of the annual Energy Center steam production distributed to campus buildings. It is estimated that a heat recovery chiller can reduce steam use at Richardson Hall by approximately 50% - 60% of current consumption.
- Provide Redundant Cooling Capacity: The heat recovery chiller could be designed to operate at full capacity to provide a back-up cooling source for the building if the primary cooling chiller fails.

The chiller proposed for this application will be similar to a Daikin Templifier Heat Recovery Chiller. The addition of a second chiller will be a relatively simple modification of a chiller plant renovation.

- The existing chiller room has sufficient space for a second chiller.
- The redundant chilled water and condenser water pumps provided for the primary cooling chiller could be used to serve the secondary heat recovery chiller without modification.
- A plate type heat exchanger will be added to remove energy from the heat recovery chiller condenser to provide full cooling capacity if the primary chiller fails.
- A plate type heat exchanger will be added to the run-around heat recovery system for AHU-1 to recover energy from laboratory exhaust air when the energy is not required to preheat outside air for AHU-1.
- Control modification will be provided for AHU-2 and AHU-3 that will limit economizer cooling to increase cooling loads when additional building heating is required.

Richardson Hall Insect Rearing Laboratory Chilled Water System

The existing chilled water system equipment serving the insect rearing lab is nearing the end of its useful life and needs to be upgraded to provide reliable cooling for the insect laboratory and greenhouses.

Water Chiller

The existing chiller has exceeded its useful life and needs to be replaced with a similar air-cooled chiller. A replacement chiller will have the following characteristics:

- Compressor Type: Scroll, minimum two compressors
- Rated Capacity: 20 tons
- Chilled Water Flow: 32 gpm
- Chilled Water Temperatures: 52°F in, 39°F out

System Redundancy

The existing chilled water system serves critical research spaces and does not have a redundant cooling source. A failure of the chiller will result in the chilled water system being inoperable. We recommend that redundant cooling capacity be provided to improve operating resiliency. Redundant capacity could be provided using one of the following methods:

- Provide the chiller with multiple refrigeration circuits. This will improve reliability if a compressor or refrigeration component fails; however, this will not prevent unit failure due to power interruption and unit control failure.
- Provide a plate heat exchanger to cool insect lab chilled water from the building chilled water system. This will provide a higher level of reliability since the system will remain operable if the air-cooled chiller is not operable.

Hydronic Water Quality

The quality of the chilled water hydronic fluid is currently unknown; however, action should be taken to ensure that water quality issues do not occur in this system as with the other hydronic systems in the building.

We recommend that a bypass filtration system be provided to remove particulate from the hydronic fluid similar to modifications being performed for the building chilled water system. System piping will also need to be thoroughly flushed and treated to establish desired water quality.

Peavy Hall Chilled Water System

The existing chilled water system is in good condition and generally functioning as intended.

System Redundancy

The chilled water system has a moderately high level of redundant capacity and components. With few exceptions, failure of individual capacity units will not make the system inoperable but may reduce system capacity. System equipment is not connected to the building standby power system.

The resiliency of the chilled water system could be improved by providing an interconnection between the Richardson Hall and Peavy Hall chilled water systems. One feature of the hydronic systems in Peavy Hall is that the chilled water and heating systems are interconnected, and water passes between the two systems. Any interconnection between the two chilled water systems will require that the building hydronic systems be isolated using a plate type heat exchanger. An interconnection would require the following work:

- Route underground piping from the Richardson Hall chiller room to the Peavy Hall chiller room. Piping would be routed out the east side of Richardson and then north to the location of the Peavy chiller room where the piping would re-enter the building.
- A heat exchanger would be installed in the primary piping loop at the discharge of chiller HP-B01.

Richardson and Peavy Hall Condenser Water System

The existing condenser water system is in good condition and generally functioning as intended. The system has sufficient capacity to serve new equipment proposed for Richardson Hall with minimal modification or adjustments.

Condenser Water Distribution

The condenser water piping system will be replaced within the Richardson Hall chiller room for the new chiller layout. The condenser water piping connecting to the Peavy Hall condenser water system will remain. See Figure 4 below.

The existing condenser water pump is past its expected service life and should be replaced with two base-mounted condenser water pumps. Each pump will be sized for 100% of the condenser water flow for redundancy.

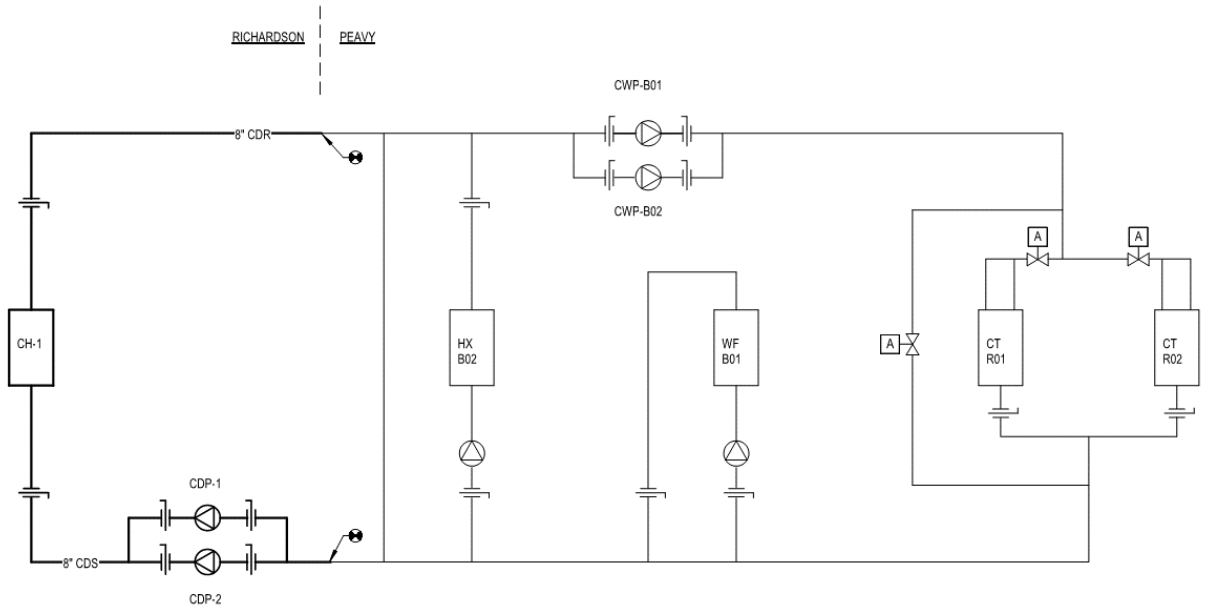

Figure 4: Richardson/Peavy Hall Condenser Water System

Emergency Refrigerant Exhaust System

The existing refrigerant monitoring system will remain. The system is capable of detecting R134A refrigerant and is connected to the building automation system for providing alarm, chiller plant shutdown, room exhaust, and open make-up air louvers.

The installation of the chiller will require 3,500 cfm of emergency exhaust airflow. The existing inline exhaust fan EF-13 is rated for 1,800 cfm. This exhaust fan should be replaced with a new utility exhaust fan located outdoors in the equipment yard outside. The exhaust fan discharge will be located 20' away from the building openings and more than 7' above grade per Oregon Specialty Mechanical Code (OSMC). A new 20"x18" exhaust duct will run from the basement to the equipment yard. Locating the exhaust fan outdoors will prevent any positively pressured hazardous air leaking through the duct into the building.

Chilled Water Quality

Chilled water quality is poor. The existing chiller needs to have sediment flushed out of the tube bundles regularly. Chilled water piping should be cleaned and flushed by a water treatment service provider. Cleaning and flushing the system will remove dirt, scale, microbiological fouling, and debris that have accumulated in the system. Once the piping has been cleaned, passivation helps form a corrosion inhibitor film on the cleaned metal surfaces. Regular testing and cleaning will maintain water quality, minimize corrosion, scale buildup, and biological growth. The recently added high-performance filter (HPF) will be used to maintain system water quality. The filter is designed to remove particles down to 5 microns.

Air Distribution Systems

The existing air distribution systems have multiple deficiencies that are affecting equipment performance and building environmental control.

Administration Wing

Air Handling Unit AHU-2 Refurbishment

Air handling unit AHU-2 is a custom indoor air handler manufactured by the Pace company. Pace is a quality manufacturer, and the functional life expectancy is typically longer than the ASHRAE suggested life expectancy. Replacement of the unit is not recommended at this time.

Clean Heating Water Coils: The poor condition of chilled water and heating water fluid has affected heating and chilled water coil performance of the air handling unit. Sediment in the system can plug parts of the coil and result in less efficient heat transfer. The heating water coils should be cleaned to restore original heat transfer performance.

Replace Chilled Water Coils: The air handler chilled water coil should be replaced with a coil with improved performance to increase overall system cooling capacity.

Provide Strainers for Coils: Strainers should be provided at the chilled and heating water supply piping into coils to prevent debris from entering the coil and control valves.

Replace Pneumatic Actuators: All pneumatic actuators should be replaced. Pneumatic control valves on the heating and chilled water coils should be replaced with new valves. Pneumatic control damper actuators operating outside air intake, return air, and exhaust air dampers should be replaced with electronic actuators.

Air Handling Unit AHU-2 Air Distribution Upgrades

Occupants along the exterior perimeter of the administration wing report space comfort issues. Occupant along the south exposure report elevated space temperatures during summer months. All occupants on exterior exposures report space temperature to be too cold in the winter months. Four conditions appear to be contributing to this problem.

Supply and Return Diffusers: Room supply and return diffusers are ceiling-mounted louvered type. Supply airflow is generally directed towards the interior of the space and not downward toward the exterior walls and windows where the heating and cooling loads occur. The inward supply discharge also directs air toward the return grille creating some level of entrainment of supply air directly into the return inlet that minimizes system effectiveness. Air circulation can be significantly improved by replacing louvered type supply air diffusers with a linear slot diffuser that directs supply air down into the space along the exterior wall.

Supply Air Stratification: During heating mode, Code requires that airflow rates be reduced to a lower level for energy efficiency. The consequence of reducing airflow rates is that the supply air temperature becomes warmer. When air is delivered at low velocity and at a higher temperature stratification occurs where warm-up will remain at ceiling level until it enters the return air grille without providing any meaningful heating of the space. Ideally, exterior spaces with variable volume terminal units would be provided with low wall return inlets to prevent this condition from occurring. However, this is not a practical solution for this building. Replacing supply diffusers will help this condition.

Modifying terminal unit warmup control sequences can also provide significant improvement. Stratification of supply air is worse during morning warm up in the heating season when the space temperature is much cooler than the supply temperature entering the space through

the supply diffuser. The modified control sequence will command the terminal unit to maximum cooling airflow during the warm-up period. This will increase the discharge velocity at the supply diffuser and will lower the supply air temperature, both of which will improve internal air circulation and minimize the adverse effects of stratification. Once the space is properly warmed-up to the desired temperature, the ongoing effects of stratification will be greatly reduced during occupied hours.

Reheat Control Valves Failure: As previously stated, the heating water fluid is causing failure and unreliable operation of heating control valves. This is believed to be contributing to the space temperature control issues.

Terminal Unit Zoning: Another contributing factor is zoning of terminal units. Four to five offices are served by one terminal unit. This means that only one space temperature can be used to control the heating and cooling output. This is further complicated by the fact that exterior windows are operable. There is little that can be done to improve these conditions without performing major system upgrades.

Laboratory Wing

Air Handling Unit AHU-1 Refurbishment

Air handling unit AHU-1 is a custom air handler manufactured by the Pace company. Pace is a quality manufacturer, and the functional life expectancy is typically longer than the ASHRAE suggested life expectancy. Replacement of the unit is not recommended at this time.

Air Handler Cabinet Refurbishment: The interior sections of this unit appear to have water pooled at the base. We also noticed rust on the interior of the unit and across the prefilter frame. The unit casing needs to be refurbished including:

- Clean and repair unit casing. Seal holes, seams, and openings airtight.
- Refinish interior and exterior of unit where damage or corrosion have penetrated the original unit. Galvanized and painted coatings to match existing.
- Replace the pre-filter housing and filter frame.

Clean Heating Water and Chilled Water Coils: The poor condition of chilled water and heating water fluid has affected heating and chilled water coil performance of the air handling unit. Sediment in the system can plug parts of the coil and result in less efficient heat transfer. The heating water and cooling coils needs to be cleaned to restore original heat transfer performance.

Restore Run-Around Heat Recovery System Operation: The run-around heat recovery system that was originally provided to use energy from laboratory exhaust air stream at EF-1 to preheat incoming outside air at AHU-1 is currently not functional. Upgrades are required to reactive this system including:

- Replace faulty pressure relief valve.
- Pressure test piping to verify there are no leaks in the system.

Refurbished Fan Motor Drives and Motor Controls: The supply fans, motors, and motor controls should be refurbished including:

- Clean fan wheel, blades, and housing to remove dirt and build up.
- Inspect fan wheel for bent blades and failing connections. Repair wheel to restore integrity to original condition.

- Replace existing fan shaft bearings to match existing configuration. Grease fittings extended to accessible location near access door.
- Replace drive belts and sheaves.
- Replace fan motor variable speed drives.

Replace Pneumatic Actuators: All pneumatic actuators should be replaced. Pneumatic control valves on the heating and chilled water coils should be replaced with new valves. Pneumatic control damper actuators operating outside air intake and fan isolation dampers need to be replaced with electronic actuators.

Air Handling Unit AHU-1 Air Distribution Upgrades

Occupants have indicated that the laboratories on all floors are too warm for much of the year. There are many conditions that are causing laboratory temperature control issues:

Unreliable Chiller Operation: As previously stated, the building chiller is in poor condition and chiller operation was intermittent in the past year. This created extremely high space temperature in lab spaces.

Chiller False Loading: When the chiller was in operation remedial operating sequences were implemented to enable the chiller to operate. This involved operating the outside air preheat coil to increase cooling load on the chilled water system to ensure that the chiller maintains the minimum load necessary for reliable operations. However, this action effectively reduced the cooling capacity of the systems. It is unclear to what degree that affects space temperatures, but likely contributed to the lab temperature control issues.

Failed Heating Water Valves: It appears that some percentage of heating water control valves have failed in the open position. One specific instance report by University staff involves overheating on the third floor. Some portion of the terminal unit reheat coil control valves serving the third floor were stuck in the open position and hot water was flowing into the coils when cooling was needed. In this instance, heating water piping to the floor was isolated and the overheating stopped.

Supply Air Diffusers: Linear slot type diffusers are being used in the exterior laboratory spaces. These types of diffusers have a high supply air velocity and are not ideal to use near fume hoods because the high velocities will disrupt laminar airflow at the front of the fume hood sash. Some of the laboratory spaces include barriers near the supply diffusers to divert airflow. This may help with fume hood operation but will also short circuit the supply air to the exhaust and prevent adequate mixing of air within the space resulting in warm spots in stagnant areas. Supply diffusers should be replaced with adjustable blade diffusers and low velocity diffusers to provide adequate air volume, air velocity, adequate mixing, and minimize effects on hood performance.

Laboratory Space Pressure Controls: Air valves control supply and exhaust airflow to the laboratories to control space pressure. Variable volume air valves have pneumatic actuators. Pneumatic tubing has failing in multiple places and is unreliable. All pneumatic space pressure controls need to be replaced.

Laboratory Space Cooling Capacity: It appears that some laboratory spaces do not have sufficient cooling capacity even when all of the conditions above are corrected and systems are operating as intended. Laboratory spaces generally require a minimum of six to eight air changes per hour of air circulation to maintain a suitable turnover rate; however, this level of air circulation is often insufficient for cooling if spaces have large exterior exposures or if large amounts of heat producing equipment is used in the lab. Additional airflow may also be

required to make up for air exhaust through fume hoods or other laboratory exhaust connections.

Table 1 Laboratory Airflows below lists the laboratory spaces, room area, ceiling height, supply airflow, and supply air change rate per hour.

| ROOM NUMBER | ROOM NAME | AREA (SQFT) | CEILING HEIGHT (FT) | MAX SUPPLY AIRFLOW (CFM) | AIR CHANGE PER HOUR (ACH) | CFM/SQFT |
|-------------|------------------------------|-------------|---------------------|--------------------------|---------------------------|----------|
| 174 | SAMPLE PREP | 499 | 9 | 3,300 | 44.1 | 6.6 |
| 174A | SAMPLE PREP | 252 | 9 | 450 | 11.9 | 1.8 |
| 170 | TEST MACHINE | 398 | 9 | 525 | 8.8 | 1.3 |
| 168 | PULPING | 272 | 9 | 1,465 | 35.9 | 5.4 |
| 166 | XRAY ROOM | 551 | 9 | 1,150 | 13.9 | 2.1 |
| 165 | WOOD POLYMER | 519 | 9 | 5,400 | 69.4 | 10.4 |
| 167 | PULP AND PAPER | 541 | 9 | 2,925 | 36.0 | 5.4 |
| 169 | MICROSCOPY | 261 | 9 | 575 | 14.7 | 2.2 |
| 171 | STEM PHYSIOLOGY | 537 | 9 | 3,200 | 39.7 | 6.0 |
| 173A | OPT INST | 119 | 9 | 250 | 14.0 | 2.1 |
| 173 | SCANNING LAB | 1,229 | 13.5 | 2,000 | 7.2 | 1.6 |
| 185 | PHY MOISTURE | 262 | 9 | 500 | 12.7 | 1.9 |
| 187 | FIBER MODELING | 786 | 9 | 4,500 | 38.2 | 5.7 |
| 191 | WHEELER COMPOSITES | 691 | 10 | 4,860 | 42.2 | 7.0 |
| 193 | RESEARCH MATERIALS RECEIVING | 519 | 10 | 900 | 10.4 | 1.7 |
| 154 | HAZARDOUS MATERIAL STORAGE | 154 | 13.5 | 525 | 15.2 | 3.4 |
| 241 | XYLARIUM | 263 | 9 | 225 | 5.7 | 0.9 |
| 243 | WOOD SCIENCE TEACHING | 1,042 | 11 | 1,350 | 7.1 | 1.3 |
| 265 | WET CHEM WILDLIFE | 515 | 9 | 981 | 12.7 | 1.9 |
| 269 | WET CHEM ECOLOGY | 542 | 9 | 981 | 12.1 | 1.8 |
| 271 | WET CHEM FIELD SUPPORT | 536 | 9 | 981 | 12.2 | 1.8 |
| 273 | WET CHEM FIELD SUPPORT | 535 | 9 | 2,981 | 37.1 | 5.6 |
| 279 | WET CHEMISTRY | 480 | 9 | 981 | 13.6 | 2.0 |
| 283 | PATHOLOGY | 810 | 9 | 1,250 | 10.3 | 1.5 |
| 283A | EQUIP | 261 | 9 | 3,675 | 93.9 | 14.1 |
| 287 | PRESERVATIVES | 531 | 9 | 1,998 | 25.1 | 3.8 |
| 289 | NDE MAT. EVAL. LAB | 865 | 9 | 3,500 | 27.0 | 4.0 |
| 291 | INST/ELEC LAB | 277 | 9 | 400 | 9.6 | 1.4 |
| 293A | ECOLOGY LAB | 267 | 9 | 450 | 11.2 | 1.7 |
| 251 | OFFICE | 245 | 9 | 300 | 8.2 | 1.2 |
| 290 | OFFICE | 265 | 9 | 400 | 10.1 | 1.5 |

| ROOM NUMBER | ROOM NAME | AREA (SQFT) | CEILING HEIGHT (FT) | MAX SUPPLY AIRFLOW (CFM) | AIR CHANGE PER HOUR (ACH) | CFM/SQFT |
|-------------|------------------------------|-------------|---------------------|--------------------------|---------------------------|----------|
| 249 | COMP LAB | 328 | 9 | 2,525 | 51.3 | 7.7 |
| 284 | INSECT REARING | 274 | 9 | 525 | 12.8 | 1.9 |
| 339 | OFFICE | 185 | 9 | 200 | 7.2 | 1.1 |
| 374 | XXX | 188 | 9 | 200 | 7.1 | 1.1 |
| 372 | COMPUTER LAB | 325 | 9 | 1,400 | 28.7 | 4.3 |
| 376 | AUTOCLAVE | 134 | 9 | 1,050 | 52.2 | 7.8 |
| 382 | EQUIP ROOM | 594 | 9 | 2,574 | 28.9 | 4.3 |
| 384 | RADIOSCOPE | 270 | 9 | 1,600 | 39.5 | 5.9 |
| 365 | WET CHEM PLANT PHYSIOLOGY | 499 | 9 | 870 | 11.6 | 1.7 |
| 367 | WET CHEM PLANT PHYSIOLOGY | 432 | 9 | 675 | 10.4 | 1.6 |
| 367A | EQUIP | 80 | 9 | 200 | 16.7 | 2.5 |
| 375 | WET CHEM PLANT PHYSIOLOGY | 524 | 9 | 975 | 12.4 | 1.9 |
| 379* | GENETICS MARKER | 793 | 9 | 1,975 | 16.6 | 2.5 |
| 383 | WET CHEM BIOTECHNOLOGY | 840 | 9 | 2,820 | 22.4 | 3.4 |
| 385 | WET CHEM BIOTECHNOLOGY | 543 | 9 | 1,980 | 24.3 | 3.6 |
| 389 | GREENHOUSE/CONTROL | 270 | 9 | 575 | 14.2 | 2.1 |
| 349 | OFFICE | 119 | 9 | 225 | 12.6 | 1.9 |
| 388A | TC LAB | 167 | 9 | 275 | 11.0 | 1.6 |
| 388 | TRANSFER STERILE | 189 | 9 | 375 | 13.2 | 2.0 |
| 386* | INSTR/EQUIP | 273 | 9 | 800 | 19.5 | 2.9 |
| 384A | IN-SITU | 107 | 9 | 425 | 26.5 | 4.0 |
| 384B | DARK RM | 159 | 9 | 425 | 17.8 | 2.7 |

Table 1: Laboratory Airflows

*Notes: Room 379 Genetic Maker was noted as having cooling issues due to the incubators in the space, and Room 386 Instr/Equip was noted as having cooling issues associated with the ultra-low temperature freezer.

Fan coil units will be provided to supplement cooling capacity in laboratories that require additional cooling. Based on our preliminary analysis the following rooms will be provided with supplemental cooling:

- 170 Test Machine
- 173 Scanning Lab
- 174 Sample Prep
- 185 Phy Moisture
- 193 Research Materials Receiving

- 241 Xylarium
- 243 Wood Science Teaching
- 265 Wet Chem Wildlife
- 269 Wet Chem Ecology
- 271 Wet Chem Field Support
- 283 Pathology
- 291 Inst/Elec lab
- 293A Ecology lab
- 284 Insect Rearing
- 365 Wet Chem Plant Physiology
- 367 Wet Chem Plant Physiology
- 375 Wet Chem Plant Physiology
- 388A TC Lab

Air Handling Unit AHU-3 Refurbishment

Air handling unit AHU-3 is a custom outdoor air handler manufactured by the Pace company. Pace is a quality manufacturer, and the functional life expectancy is typically longer than the ASHRAE suggested life expectancy. Replacement of the unit is not recommended at this time.

Clean Heating Water Coils: The poor condition of chilled water and heating water fluid has affected heating and chilled water coil performance of the air handling unit. Sediment in the system can plug parts of the coil and result in less efficient heat transfer. The heating water coils should be cleaned to restore original heat transfer performance.

Replace Chilled Water Coils: The performance of the AHU-3 cooling coil has been problematic since the initial commissioning of the facility. Originally the cooling coil was determined to be improperly manufactured and was repaired in the field. Even after the coil repairs were completed cooling of the offices was problematic. The air handler chilled water coil should be replaced with a coil with improved performance to increase overall system cooling capacity.

Provide Strainers for Coils: Strainers should be provided at the chilled and heating water supply piping into coils to prevent debris from entering the coil and control valves.

Replace Pneumatic Actuators: All pneumatic actuators should be replaced. Pneumatic control valves on the heating and chilled water coils should be replaced with new valves. Pneumatic control damper actuators operating outside air intake, return air, and exhaust air dampers should be replaced with electronic actuators.

Air Handling Unit AHU-3 Air Distribution Upgrades

Occupants along the exterior perimeter of the offices in the south wing report space comfort issues. Occupant report elevated space temperatures during summer months and low temperatures in the winter months. Four conditions appear to be contributing to this problem.

Supply and Return Diffusers: Room supply and return diffusers are ceiling-mounted louvered type. Supply airflow is generally directed towards the interior of the space and not downward toward the exterior walls and windows where the heating and cooling loads occur. The inward supply discharge also directs air toward the return grille creating some level of entrainment of supply air directly into the return inlet that minimizes system effectiveness. Air circulation

can be significantly improved by replacing louvered type supply air diffusers with a linear slot diffuser that directs supply air down into the space along the exterior wall.

Supply Air Stratification: During heating mode, Code requires that airflow rates be reduced to a lower level for energy efficiency. The consequence of reducing airflow rates is that the supply air temperature becomes warmer. When air is delivered at low velocity and at a higher temperature, stratification occurs where warm-up will remain at ceiling level until it enters the return air grille without providing any meaningful heating of the space. Ideally, exterior spaces with variable volume terminal units would be provided with low wall return inlets to prevent this condition from occurring. However, this is not a practical solution for this building. Replacing supply diffusers will help this condition.

Modifying terminal unit warmup control sequences can also provide significant improvement. Stratification of supply air is worse during morning warm up in the heating season when the space temperature is much cooler than the supply temperature entering the space through the supply diffuser. The modified control sequence would command the terminal unit to maximum cooling airflow during the warm-up period. This will increase the discharge velocity at the supply diffuser and will lower the supply air temperature, both of which will improve internal air circulation and minimize the adverse effects of stratification. Once the space is properly warmed-up to the desired temperature, the ongoing effects of stratification will be greatly reduced during occupied hours.

Reheat Control Valves Failure: As previously stated, the heating water fluid is causing failure and unreliable operation of heating control valve. This is believed to be contribution to the space temperature control issues.

Terminal Unit Zoning: Another contributing factor is zoning of terminal units. Four to five offices are served by one terminal unit. This means that only one space temperature can be used to control the heating and cooling output. This is further complicated by the fact that exterior windows are operable. There is little that can be done to improve these conditions without performing major system upgrades.

Air Handling Units AHU-4 and AHU-5 Refurbishment

Air handling unit AHU-4 and 5 are a custom outdoor air handler manufactured by the Pace company. Pace is a quality manufacturer, and the functional life expectancy is typically longer than the ASHRAE suggested life expectancy. Replacement of the unit is not recommended at this time.

Clean Heating Water and Chilled Water Coils: The poor condition of chilled water and heating water fluid has affected heating and chilled water coil performance of the air handling unit. Sediment in the system can plug parts of the coil and result in less efficient heat transfer. The heating water coils should be cleaned to restore original heat transfer performance.

Replace Chilled Water Coils: The performance of the AHU-4 and 5 cooling coils were designed for an entering water temperature of 39°F and an outside air temperature of 89°F. Both design temperatures are not consistent with actual operating conditions. Chilled water coils should be replaced with coils designed for actual operating conditions.

Provide Strainers for Coils: Strainers should be provided at the chilled and heating water supply piping into coils to prevent debris from entering the coil and control valves.

Replace Pneumatic Actuators: All pneumatic actuators should be replaced. Pneumatic control valves on the heating and chilled water coils should be replaced with new valves. Pneumatic control damper actuators operating outside air intake, return air, and exhaust air dampers should be replaced with electronic actuators.

Air Handling Units AHU-4 and AHU-5 Air Distribution Upgrades

Occupants have indicated that the Insect Rearing Laboratory and Greenhouse 3 are too warm in the summer months. There are many conditions that are causing laboratory temperature control issues:

Chiller Operation: Chiller CH-2 is in poor condition and chiller operation was unreliable. The chiller is also not providing the chilled water supply temperature that was originally intended. The chiller currently operates with a supply temperature of 44°F. Operating at a higher supply temperature can have a large effect on air handler cooling coil capacity. The replacement chiller performance needs to be coordinated with the cooling coil design performance.

Laboratory Space Pressure Controls: Constant volume air valves control supply and exhaust airflow to the laboratories to control space pressure.

Laboratory Space Cooling Capacity: Occupants in the laboratory spaces have indicated that the laboratories on all floors are too warm in the summertime. High temperatures reported on the third floor are partially due to the heating water system operating all summer to provide a false load to the chiller to keep it operational. Heating water valves at the reheat coils on the third floor were stuck in the open position and hot water was flowing into the coils when cooling was needed. The heating water to the floor was isolated to solve this.

Insect Rearing Biological Containment Laboratory Certification

The Insect Rearing Laboratory and Greenhouse 3 were designed as an ABSL3Ag containment laboratory. The laboratory was certified in 2005 and became uncertified in 2017 when the autoclave failed. The laboratory can be recertified; however, this will require repairs, upgrades, and testing including repair or replacement of the autoclave. Laboratory systems included in the certification process include.

- Containment boundary
- Self-closing double door access
- Access controls
- Shower
- Hand washing sink
- Autoclave
- Effluent decontamination system
- HVAC system
- HEPA filter performance

Exhaust Unit EF-1 Replacement

Exhaust Unit EF-1 has exceeded its useful life and needs replaced. Following is an assessment of the existing unit.

Unit Replacement: Due to the age and current condition of unit components it is recommended that the unit be replaced. Refurbishment of the existing unit is not recommended.

Exhaust Fans: Exhaust fans have a history of failures and require increasing amounts of maintenance to keep the system operational. Fan isolation dampers are unreliable making routine service difficult.

Run-around Heat Recovery System: Heat recovery coils that recover energy from the laboratory exhaust air do not appear to have filters and are not constructed to facilitate maintenance. The system is currently not operational.

Heat Recovery Coil: The condition of the heat recovery coil in the exhaust plenum is unknown. Existing as-built plans do not show a filter upstream of the heat recovery coil. Maintenance of the heat recovery coil system in the exhaust plenum is a concern. Installation of filters and regular filter replacement is necessary to keep the heat recovery coil clean. Isolation dampers on either side of the heat recovery coil section need to be completely sealed to safely gain access to the heat recovery coil section without shutting down the exhaust fan. A new exhaust fan system can include a heat recovery section or be provided without. If included, the heat recovery plenum should have filter and coil isolation dampers and a bypass section to enable accessible filter replacement and coil cleaning without shutting down laboratory exhaust.

Capacity and Configuration: The replacement units will be similar to the existing, with five variable volume exhaust fans. Four of the fans will be able to handle the full design volume of laboratory exhaust air and one fan will be provided for emergency backup. The fans will vary airflow based on exhaust duct static pressure. This will eliminate the need for bypass dampers on the exhaust air plenum. We recommend hiring a wind consultant to analyze the building wind dynamics to determine the height of the exhaust air plume required at varying operating conditions. A variety of laboratory fan types will be considered for replacement, but it is likely to be a vertical inline fan similar to the existing so that the assembly will fit within the space provided.

Replacement of the exhaust fan system and heat recovery system will require an extended shutdown of the laboratory exhaust. The final selection will need to be reviewed by the CM/GC for constructability and to determine estimated shutdown times.

Laboratory Process Exhaust Fans

Utility exhaust fans EF-2, EF-3, EF-5, EF-6, EF-11, EF-17, and EF-18 are past their functional life expectancy and are showing signs of corrosion. These fans should be replaced with new utility exhaust fans. Fans will include heavy gauge, fully welded housings, with corrosion resistant interior and exterior.

The existing fans have spring isolators directly attached to the lightweight fan base. This can be problematic as the fans will tend to resonate at low frequencies. The new fans should be mounted on a rigid spring isolated equipment base. This will keep the equipment running with a minimum of vibration.

High Bay and Kiln

There are no known deficiencies noted for the High Bay and Kiln areas. Revisions to the HVAC systems serving the Kiln area will be provided for the remodeled wood treatment laboratory as documented in the Richardson Hall Chiller Plant and HVAC Upgrades dated December 14, 2022.

Recommended Facility Improvements

The section describes HVAC system improvements proposed for Richardson Hall. Improvements also include associated demolition required to facilitate MEP improvements.

Base Scope of Work

Improvements related to the chiller water system and controls upgrades were identified as required elements for this project in the original Request for Proposal and are considered Base Scope items. A detailed description of the scope of work is described in the OSU Richardson Hall Chiller Plant and HVAC Upgrades schematic design report dated December 14, 2022. This work generally includes the following:

- Replace chiller and upgrade chilled water system.
- Clean and flush chilled water system to improve water quality.
- Replace chiller room emergency refrigerant exhaust fan.
- Replace the Siemens building automation system including replacing pneumatic control valves and damper actuators.
- Replace the Phoenix laboratory space pressure control system including automatic controls and constant volume and variable volume air valves.
- Revise sequence of operations for air handling units AHU-2 and AHU-3 to include a morning warm up routine.
- Upgrades to Wood Treatment Lab room 197B

High Priority Recommendations

Recommendations included in this section of the report are considered high priority and are recommended for immediate implementation.

Steam Systems

- Demolish high to medium pressure steam pressure reducing valve assembly.
- Demolish abandoned high pressure steam piping between wet mechanical room and basement chiller room.
- Replace damaged steam pipe insulation in the basement wet mechanical room.

Heating Water System

- Water service treatment provider to clean and flush heating water system.
- Provide high performance filter (HPF) system on closed loop heating water system. Basis of design is Chem-Aqua hot water HPF closed loop filter.

Chilled Water System

- Provide 100-ton heat recovery chiller, piping, controls, and related appurtenances. This is in addition to the 400-ton chiller provided in the base bid.
 - Provide a plate and frame heat exchanger to cool insect lab chilled water from the building chilled water system to provide redundancy.
- Upgrade insect lab chilled water system.
 - Demolish and replace air cooled chiller CH-2.

- Provide a plate heat exchanger to cool insect lab chilled water from the building chilled water system.
- Provide a bypass filtration system to remove particulate from insect lab chilled water system hydronic fluid similar to modifications being performed for the building chilled water system. System piping will also need to be thoroughly flushed and treated to establish desired water quality.

Air Distribution Systems

Administration Wing

- Demolish and replace air handling unit AHU-2 heating and cooling coil valve piping with new valves and trim. Include a strainer on the coil supply.
- Flush and clean heating water coils in AHU-2.
- Replace AHU-2 chilled water coil.
- Replace supply diffusers along the south perimeter walls of the administration wing.

Laboratory Wing

- Refurbish air handler AHU-1.
 - Clean and repair unit casing.
 - Flush and clean heat recovery, heating, and chilled water coils.
 - Replace prefilter housing and filter frame.
 - Refurbish fan motor drives and controls.
 - Clean fan wheel, blades, and housing.
 - Replace fan shaft bearings.
 - Replace drive belts and sheaves.
- Demolish and provide new laboratory exhaust fan EF-1.
- Demolish and provide new laboratory exhaust fans EF-5, EF-6, and EF-11.
- Recertify Insect Rearing Biological Containment Laboratory as a ABSL3Ag containment laboratory.
- Demolish and provide new laboratory exhaust fans EF-2, EF-3, EF-17, and EF-18.
- Demolish and provide new chilled water coil inside air handler AHU-3.
- Clean air handler AHU-4 and AHU-5.
- Replace supply diffusers along the west perimeter walls of the laboratory wing.
- Replace linear slot diffusers within the laboratory spaces with supply grilles.
- Restore run-around heat recovery system operation.
- Provide fan coils for supplemental cooling in laboratory spaces.

The following items should be considered in the future to maintain reliability and improve performance. We recommend the following scope of work as a lower priority.

Lower Priority Scope of Work

Recommendations included in this section of the report are considered lower priority and may be implemented if project funding is available or planned for a future construction project.

Following is a summary of the proposed renovation work.

Heating Water System

- Demolish heating water pumps HWP-1 and HWP-2
- Provide new heating water pumps HWP-1 and HWP-2. The pumps will include variable frequency drives.

Chilled Water System

- Provide interconnection of chilled water piping between Richardson Hall and Peavy Hall for chilled water redundancy.
- Provide a heat exchanger in the Peavy Hall mechanical room to connect the chilled water plant together.

Air Distribution Systems

Administration Wing

- Demolish and replace terminal unit reheat coil valve piping with new valves and trim. Include a strainer on the coil supply.

Laboratory Wing

- Demolish and replace terminal unit reheat and duct-mounted reheat coil valve piping with new valves and trim. Include a strainer on the coil supply.
- Demolish and provide new heat recovery coil plenum.

PROJECT COSTS

Budget Cost Projections

Budget projections have been provided to assist in initial project scope development and are based on general rules of thumb, past project experience, and engineers' judgement. The projections are intended to represent the direct construction cost that would be obtained from a public bid and, as such, do not include costs for professional services, permits, and Owner's administration costs. Allocations for these costs should be added to the estimates of probable construction cost shown below. The estimates include the following additional estimating parameters:

- General contractor mark-up: 12%. It is assumed that a general contractor will be the prime contractor.
- Insurance, bonds, general conditions: 10%
- Escalation factor: 4% based on a one-year duration to a bid date.

Base Scope of Work

| PROJECT COST SUMMARY | PROBABLE DIRECT CONSTRUCTION COST |
|--|--|
| Replace chiller and upgrade chilled water system | \$525,000 |
| Replace the Siemens BAS system including replacement of pneumatic valve and damper actuators | \$885,000 |
| Replace Phoenix laboratory space pressure control systems | \$678,750 |
| Revise sequence of operations for air handling units AHU-2 and AHU-3 to include a morning warmup | \$2,000 |
| Wood Treatment Lab 197B Upgrades | 235,000 |
| Subtotal | \$2,325,750 |
| Design Contingency (5%) | \$116,290 |
| Construction Contingency (10%) | \$232,600 |
| Construction Scope Subtotal | \$2,674,640 |
| General Conditions Noted Above | \$695,400 |
| Project Total | \$3,370,040 |

High Priority Recommendations

| PROJECT COST SUMMARY | PROBABLE DIRECT CONSTRUCTION COST |
|--|--|
| Steam system upgrades | \$20,000 |
| Heating water system upgrades | \$16,000 |
| Chilled water system upgrades Install heat recovery chiller Upgrade insect lab chiller CH-2 and associated chilled water system. | \$370,000 |
| Upgrade AHU-1 | \$150,000 |
| Upgrade air handler AHU-2 | \$75,000 |
| Replace supply diffusers in administration wing and laboratory wings | 50,000 |
| Replace exhaust fan EF-1 | \$500,000 |

| | |
|---|--------------------|
| Replace laboratory exhaust fans EF-2, EF-3, EF-5, EF-6, EF-11, EF-17, and EF-18 | 80,000 |
| Upgrade air handler AHU-3 | 75,000 |
| Clean air handlers AHU-4 and AHU-5 | 20,000 |
| Restore heat recovery system operation | 35,000 |
| Provide fan coils for supplemental cooling | 160,000 |
| Subtotal | \$1,551,000 |
| Design Contingency (15%) | \$235,650 |
| Construction Contingency (10%) | \$155,100 |
| Construction Scope Subtotal | \$1,941,750 |
| General Conditions Noted Above | \$504,900 |
| Project Total | \$2,446,650 |

Low Priority Recommendations

| PROJECT COST SUMMARY | PROBABLE DIRECT CONSTRUCTION COST |
|---|--|
| Upgrade heating water system | \$40,000 |
| Upgrade chilled water system | \$150,000 |
| Replace reheat coil valves and piping | \$200,000 |
| Replace existing heat recovery exhaust plenum | \$110,000 |
| Recertify insect rearing laboratory | \$350,000 |
| Subtotal | \$850,000 |
| Design Contingency (15%) | \$127,500 |
| Construction Contingency (10%) | \$85,000 |
| Construction Scope Subtotal | \$1,062,500 |
| General Conditions Noted Above | \$276,250 |
| Project Total | \$1,338,750 |

Implementation

Implementation Considerations

The building is to remain occupied during construction. Upgrades to the system will need to be completed with as little downtime as possible. The following items will be considered for scheduling construction of the recommended upgrades.

Steam Systems

- Steam system improvements will be done during the summer when heating is not needed for freeze protection. There will be a short downtime of building steam used for HVAC re-heat, domestic hot water, lab hot water, autoclaves, and kilns.

Heating Hot Water

- Heating water pumps are 100% redundant and can be replaced one at a time without affecting heating water flow to the building.

Chilled Water System Upgrades

- Upgrades to the chilled water system will be done during the winter when the chilled water system is typically shut down. Chilled water piping will be cleaned and flushed prior to operation of new chiller. Chilled water piping should be routed to the chilled water coils in air handling unit AHU-4 and AHU-5 prior to demolition of the air-cooled chiller CH-2.

Air Distribution Systems

Air Handler AHU-1

- Refurbishing air handling unit AHU-1 will require the shutdown of one of the fan sections. This will reduce supply airflow capacity to the laboratories by 50% of the maximum.
- Upgrades to air valves, and supply diffusers will need to be scheduled with building users prior to construction.

Air Handler AHU-2 and AHU-3

- Refurbishing of air handling units AHU-2 and AHU-3 will require a shutdown to replace the cooling coil. This will need to be scheduled with building users.
- Upgrades to terminal units and supply diffusers will need to be scheduled with building users prior to construction.

Air Handler AHU-4 and AHU-5

- Refurbishing of air handling unit AHU-4 can be done one section at a time without a complete shut-down of HVAC to the greenhouse. Refurbishing of air handling unit AHU-5 can be done one section at a time without a complete shut-down of HVAC to the greenhouse. New chilled water piping can connect to the chilled water coils in air handling unit AHU-4 and AHU-5 prior to demolition of the air-cooled chiller CH-2.

Exhaust Unit EF-1

- Replacement of laboratory exhaust fan EF-1 will require an extensive shut down of laboratory exhaust. Exhaust shut down will need to be coordinated with OSU facilities and building users.

Process Exhaust Fans

- Replacement of laboratory exhaust fans EF-2, EF-3, EF-5, EF-6, EF-11, EF-17, and EF-18 will require shut down for a short time to replace fan. Two lab hoods in the radioisotope and exhaust for the hazardous storage room will be affected.



Appendix A

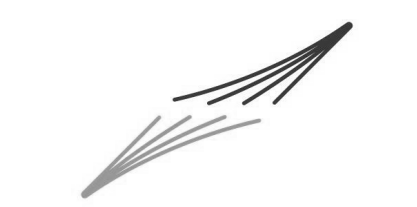

Not For Construction

Richardson Hall Chiller Controls Replacement

Enter address here

OWNER: ?

STEAM & CONDENSATE DIAGRAM

DESIGNED: _____
 DRAWN: PZL
 CHECKED: _____

DATE: 12.20.2021
 PROJECT: V015.24

M623

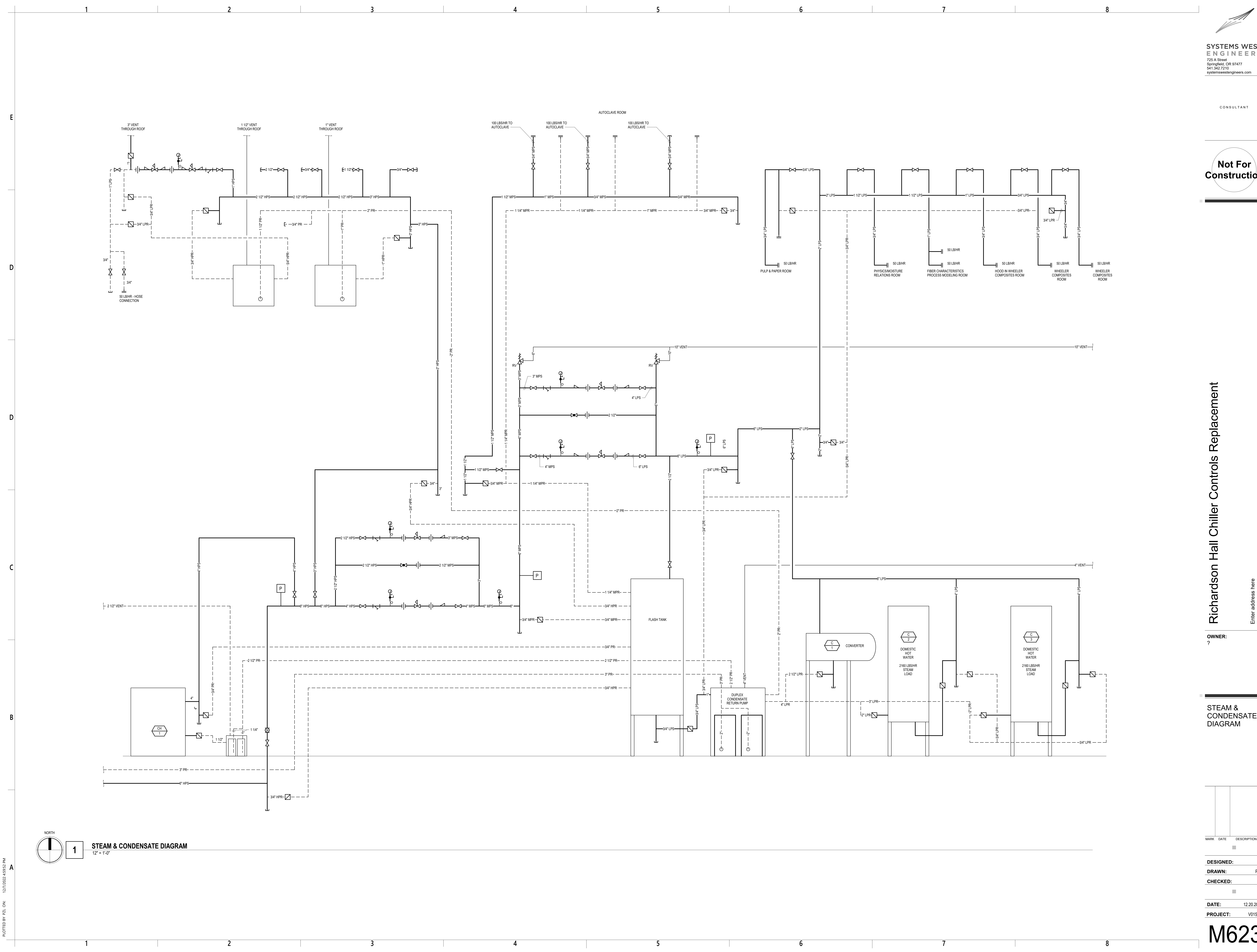

1 STEAM & CONDENSATE DIAGRAM
 12" = 1'-0"

PLOTTER BY PZL ON 12/20/21 4:59:53 PM



DECEMBER 14, 2022

OSU Richardson Hall Chiller Plant and HVAC Upgrades

Richardson Hall Chiller Replacement

V015.24

725 A Street Springfield, OR 97477
550 NW Franklin Blvd., Suite 448 Bend, OR 97703



SystemsWestEngineers.com
(541) 342-7210

TABLE OF CONTENTS

INTRODUCTION 1

OVERALL PROJECT DESCRIPTION..... 1

GENERAL PROJECT REQUIREMENTS 2

CHILLED WATER PLANT..... 2

WOOD TREATMENT LAB 197B.....12

CONTROLS REPLACEMENT AND UPGRADE.....22

INTRODUCTION

Richardson Hall is a 100,000 square-foot, three-story science building with basement that was constructed in 1999. Chilled water for building cooling is provided by a water-cooled chiller in the basement mechanical room and an air-cooled chiller on the roof. Chilled water is supplied to air handlers on the roof. The air handlers supply air to the spaces through variable air volume (VAV) terminal units with heating water coils. The following deficiencies have been noted regarding the existing HVAC system:

- The water-cooled chiller is oversized and not able to provide reliable cooling to the building during part load conditions.
- HVAC systems are not able to provide adequate cooling to the south wing of the building.
- The existing pneumatic control system is leaky and not reliable.
- The existing DDC control system is outdated and does not provide the Owner with the desired functionality.

Additionally, the University would like to perform upgrades to Room 197B for the purpose of adding a wood treatment lab to the space. Recommendations for modifications to fire sprinklers, HVAC, plumbing, and electrical were noted in the Oregon State University Richardson Hall Wood Treatment Plant Feasibility Study. Date June 25, 2021.

Following is a narrative description of HVAC and electrical system upgrades proposed for the Richardson Hall Chiller Replacement and Wood Treatment Lab project. The purpose of this narrative is to provide an understanding of existing building conditions, project requirements, proposed system upgrades, engineering concepts, and material and equipment standards to demonstrate compliance with Owner's Project Requirements.

OVERALL PROJECT DESCRIPTION

The overall project consists of the following items:

- Replace the existing chiller and chilled water plant serving Richardson Hall. Reconnect to the existing cooling towers at Peavy Hall. This replacement will include the following:
 - Provisions for connecting a temporary chiller to the chilled water distribution system.
 - Assess the potential to again combine the chiller systems for Peavy and Richardson, either in a redundancy basis or as a singular unit.
 - Determine the requirements for connecting to a new district utility plant.
- Develop recommendations to replace HVAC pneumatic controls with DDC controls.
- Develop recommendations to correct HVAC cooling deficiencies in the south wing.
- Upgrade the Wood Pressure Treatment Lab 197B HVAC, plumbing, fire protection, and electrical systems to meet the current building codes.

GENERAL PROJECT REQUIREMENTS

Local Building Codes

The following building codes are adopted by the State of Oregon, and are collectively referred to as the “Code”:

- Oregon Structural Specialty Code
- Oregon Elevator Specialty Code
- Oregon Plumbing Specialty Code
- Oregon Mechanical Specialty Code
- Oregon Boiler and Pressure Vessel Specialty Code
- Oregon Energy Efficiency Specialty Code
- Oregon Electrical Code
- Oregon Fire Code

National Codes and Standards

The design of building systems will conform to the most recent version of the following industry and institutional codes and standards:

- Oregon State University Design and Construction Standards

Seismic Design Criteria

Anchorage and support of plumbing, mechanical, and electrical systems will be provided in accordance with the Oregon Structural Specialty Code for the project site.

Sustainability and Energy Efficiency

Sustainable materials and construction practices will be implemented where appropriate, as determined by the Owner. The energy efficiency of mechanical and electrical systems will be given high priority. At a minimum, system performance and equipment efficiencies will conform to the Codes and Standards cited above. Additional energy conservation features will be implemented where cost effective or beneficial, as determined by the Owner. This project has no specific sustainability goals.

CHILLED WATER PLANT

Existing Conditions

Heating, Ventilating, and Air-Conditioning

The following is a description of the existing HVAC systems at Richardson Hall along with notable conditions observed during an on-site field survey.

A schematic of the chilled water system is shown in Figure 1 below. The Richardson Hall chilled water plant has the following major elements:

- Chillers
- Primary chiller pumps
- Secondary distribution pump
- Intertie pump
- Cooling towers
- Condenser water pumps.
- Emergency refrigerant exhaust system
- Building automation system

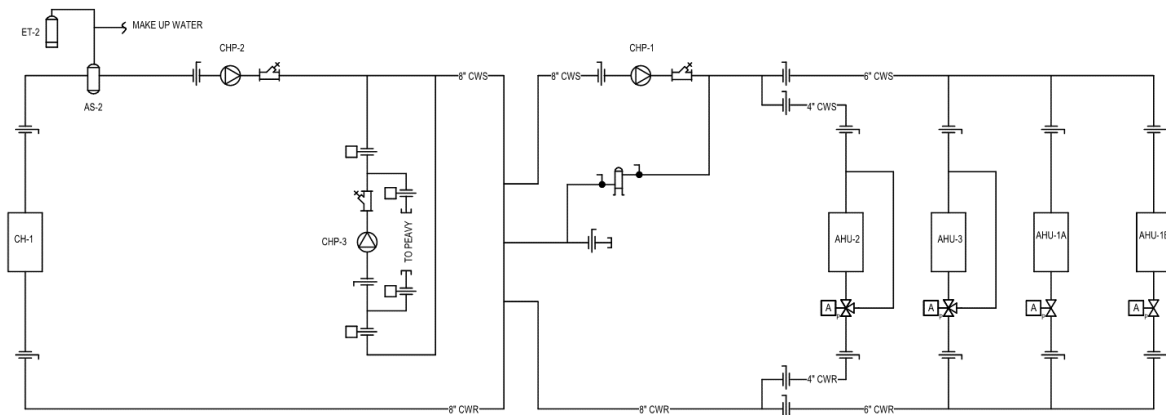

Figure 1 Richardson Hall Existing Chilled Water System Diagram

Chillers

Chilled water for building cooling is provided by a water-cooled chiller CH-1 in the basement chiller plant and an air-cooled chiller CH-2 on the roof. Chiller CH-1 serves air handler AHU-1, AHU-2, and AHU-3. Chiller CH-2 serves air handlers AHU-4 and AHU-5.

Chiller CH-1 is a 510-ton Carrier Model 19XRV centrifugal chiller designed to cool 1,175-gpm of water from 54F to 44F. The chilled water plant is a primary-secondary configuration. The primary chilled water pump supplies a constant volume of 1,175-gpm through the chiller, and the secondary pumps operate at a variable volume to maintain a differential pressure in the chilled water piping to the rooftop air handlers. The system includes a pump (CWP-3) to connect the chilled water from Richardson Hall to the former Peavy Hall Chilled water plant. Peavy hall was reconstructed in 2017 and this connection between buildings was removed.

The condenser water section of chiller CH-1 is cooled by condenser water from cooling towers on the roof of Peavy Hall. The chillers condenser is designed for 1385-gpm of 80F entering water temperature and 90F leaving water temperature. The condenser water system is described in the sections below.

Chiller CH-2 is a York Model WIL air cooled chiller designed to cool 32.5-gpm of water and glycol solution from 52F to 39F. The chiller is in a primary only configuration with primary pumps circulating a constant volume of water through the chiller to the rooftop air handlers. The chilled water in this system contains a glycol mixture to prevent freezing

Primary Chiller Pump

Primary pump CHP-2 operates at a constant flow circulating water through 8-inch diameter piping to chiller CH-1. The pump is a Taco model FE600 end suction pump with a 20 HP motor and is rated for 1175-gpm at 45 feet of head pressure.

Primary Pumps CHP-4 and CHP-5 operate in a lead lag arrangement to provide constant flow circulating water through 2-1/2-inch diameter piping between the chiller and air handler AHU-4 and AHU-5 cooling coils. Both pumps are in line type with a 0.75 HP motor and rated for 32.5-gpm at 28 feet of head pressure.

Secondary Distribution Pump

Secondary pump CHP-1 operates as a variable volume flow to maintain a pressure differential in the piping distribution system. The pump circulates water from the primary chilled water system to air handlers AHU-1, AHU-2, and AHU-3 on the roof. The pump is a Taco model FE600 end suction pump with a 15 HP motor and is rated for 660-gpm at 70 feet of head pressure.

Intertie Pump

An intertie pump CHP-3 was originally designed to connect the chilled water systems at Richardson Hall and Peavy Hall together. Automatic valves on the interconnecting piping allow chilled water from Peavy Hall to be pumped to the Richardson Hall primary loop, or chilled water from Richardson Hall to be pumped to the Peavy chilled water loop. The interconnection of chilled water plants was abandoned in 2017 when Peavy Hall was reconstructed. Pump CHP-3 has been turned off and remains in the Richardson chiller room. The pump is a Taco model FE600 end suction pump with a 10HP motor and is rated for 660-gpm at 36 feet of head pressure.

Cooling Towers

A schematic diagram of the condenser water system is shown in Figure 2 below. The condenser water system serves both Richardson Hall and Peavy Hall. Two Marley SPX crossflow cooling towers CT-R01 and CT-R02 on the roof of Peavy hall provide condenser water to a water-to-water heat exchanger HX-B02 in the Peavy Hall basement mechanical room, and to the chiller CH-1 in the Richardson Hall basement. A modulating bypass valve between the condenser water supply and condenser water return lines modulates to maintain a minimum condenser water temperature supply. Each cooling tower has the capacity to cool 785-gpm of water from 89F to 76F at an ambient wet bulb temperature of 73F.

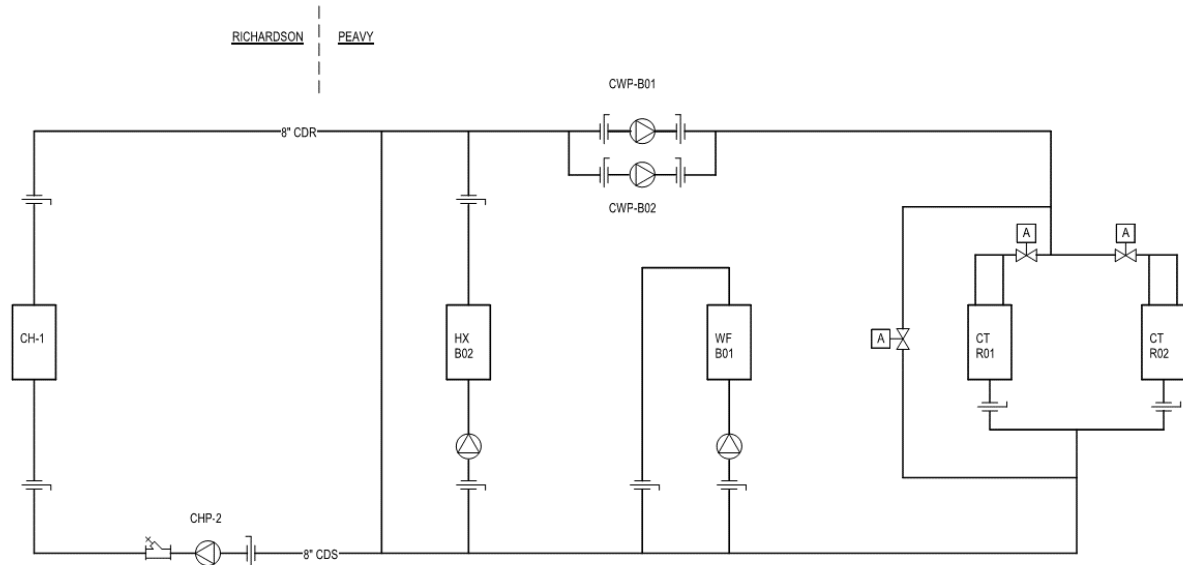

Figure 2 Richardson Hall Condenser Water System Diagram

Condenser Water Pumps

Condenser water pumps CWP-B01 and CWP-B02 operate as variable volume flow of condenser water between the Peavy basement and the cooling towers. The pumps are both Bell and Gossett model 1510 end suction pumps with 15 HP motors and are rated for 830 gpm at 50 feet of head pressure.

Condenser water pump CWP-B03 operates to supply constant volume condenser water to a water-to-water heat exchanger HX-B02 in the Peavy mechanical room. The heat exchanger is used to either recover waste heat from the condenser water system and supply the condenser side of the heat recovery chiller or to reject heat from the heat recovery chiller to the condenser water system. The pump is a Bell and Gossett model 1510 end suction pump with a 3 HP motor and rated for 475 gpm at 15 feet of head pressure.

Condenser water pump CWP-1 operates at constant volume to supply condenser water to Richardson Hall chiller CH-1. The pump circulates water between the Richardson Hall chiller CH-1 and the condenser water loop in the basement of Peavy Hall. The pump is a Taco end suction pump with a 30 HP motor and is rated for 1000-gpm at 50 feet of head pressure.

Emergency Refrigerant Exhaust System

An emergency refrigerant detection system has been provided for the Richardson Hall chilled water plant. The detection system includes a MSA Model Chillgard LE refrigerant monitor. The monitor will automatically stop the chillers, operate emergency ventilation exhaust fan EF-13, and open outside air dampers for makeup air when a refrigerant leak is detected.

Exhaust fan EF-13 is a Greenheck Model BSQ-140-5 inline fan designed for an emergency ventilation rate of 1,800 cfm at 0.5-inch static pressure.

Notable Conditions:

- Chiller CH-1 was installed in 2004 and is near its ASHRAE expected service life of 23 years.
- Chiller CH-1 tube bundles need regular maintenance to flush out sediment from corrosion. Isolation valves do not close completely so the chilled water system needs to be drained

to perform this task. Refilling the chilled water system adds to the corrosion issues in the chilled water piping.

- Chiller CH-1 is not able to operate reliably at partial cooling load conditions. This is being overcome by controlling the air handlers to heat the air before it enters the cooling coil.
- Chiller CH-1 relief vent piping discharges approximately 7' above grade in the landscaped area to the east of the building. The point of discharge is near doors and intake air louvers to the chiller room. OSMC 1105.7 requires pressure relief devices terminate outdoors not less than 15 feet above adjoining grade level and not less than 20 feet from opening or exit.
- Chiller CH-2 was installed in 1999 and is past its ASHRAE expected service life of 20 years.
- The primary pumps CHP-2, CHP-4, and CHP-5 were installed in 1999 and are past their ASHRAE expected service life expectancy of 20 years.
- The secondary pumps CHP-1 and intertie pump CHP-3 were installed in 1999 and are past their ASHRAE expected service life expectancy of 20 years.
- Chiller CH-2 is currently providing 44°F to air handlers AHU-4 and AHU-5 cooling coils.
- The intertie pump CHP-3 is no longer in use. Underground piping between the buildings appears to be abandoned in place.
- The cooling towers CT-R01 and CT-R02 were installed in 2018 and appear to be in good condition.
- Condenser water pumps CWP-B01, CWP-B02, and CWP-B03 were installed in 2018 and appear to be in good operating condition.
- Condenser water pump CWP-1 was installed in 1999 and is past its ASHRAE recommended service life of 20 years.
- An emergency exhaust fan discharges to the east of the chiller room approximately 7' above grade. OSMC 1105.6.1 requires 20' distance between exhaust and openings into the building.
- DDC looks at the CHW valve open command of the three AHUs it serves and OAT > 65°F (adj), enables the constant volume CWP, which signals the Peavy cooling tower to operate. After a time delay, the chiller is enabled. The chiller controls the constant volume primary pump and the secondary pump VFD modulates to maintain 25psi DP.
- The refrigerant monitor appears to be of recent vintage and is in good operating condition.

Electrical

The facility's existing service entrance main switchboard (MDH) is rated at 3,000-amps, 480/277 volts, 3-phase, 4-wire with a 3,000-amp main circuit breaker. The MDH is located in the basement main electrical room adjacent to the chiller room. The peak load on the MDH is unknown at this time but will be coordinated with the utility. Existing panel BHM is also in the main electrical room and is 400-amp, 480/277 volt, 3-phase, 4-wire and is fed from existing switchboard (MDH); however, the existing circuit breaker in MDH feeding panel BHM is only 300 amp, 3-pole. Existing panel EBH is also in the main electrical room and is 100-amp, 480/277 volt, 3-phase, 4-wire and is fed from existing emergency panel EDH via automatic transfer switch ATS-1.

- The existing chiller CH-1 is served by a 600-amp circuit breaker in existing switchboard MDH. Existing feeder conductors are to be removed as well as the flexible conduits extending to the existing chiller controller. Existing parallel 2-1/2-inch conduits will remain for re-use.
- Existing primary pump CHP-1 is fed from a 40-amp, 3-pole circuit breaker in existing panel BHM. Existing conduit, conductors, and circuit breaker will be removed.
- Existing secondary pump CHP-2 is fed from a 60-amp, 3-pole circuit breaker in existing panel BHM. Existing conduit, conductors, and circuit breaker will be removed.
- Existing intertie pump CHP-3 is fed from a 30-amp, 3-pole circuit breaker in existing panel BHM. Existing conduit and conductors to be removed. Existing circuit breaker will remain and be re-used for a different load.
- Existing condenser water pump CWP-1 is fed from an 80-amp, 3-pole circuit breaker in existing panel BHM. Existing conduit, conductors, and circuit breaker will be removed.
- Existing refrigerant exhaust fan EF-13 is fed from an existing 20-amp, 3-pole circuit breaker in existing panel EBH. EF-13 shares this circuit breaker with CP2. EF-13 will be removed from this circuit breaker. Existing conduit and conductors will be removed.

Systems Descriptions

Heating, Ventilating and Air Conditioning

The existing chilled water plant will be demolished and replaced with a new chiller capable of operating at reduced capacities to meet the building load. The chiller will connect to the existing condenser water system at Peavy Hall. The chilled water distribution system will be arranged in a primary only configuration.

Following is a description of proposed systems, equipment, and controls for the Richardson Hall Chiller Plant upgrades:

Chiller

One 400-ton chiller with magnetic bearing compressors will cool 740 gpm of water from 56°F to 42°F. Compressors will have variable speed drive motor controls to modulate the pump to meet building cooling loads. A new concrete pad will be provided for the chiller.

- Chiller: Daikin magnetic bearing chiller model WME092 400-ton capacity

Primary Distribution System

The primary-secondary chiller system will be replaced with a variable volume primary only cooling system. Three-way control valves on air handlers AHU-2 and AHU-3 will maintain the minimum flow through the chillers. See Figure 3 below.

Two base-mounted chilled water pumps will be provided for redundancy. Each pump is rated at the design chilled water flow rate through the chiller. Pumps will be installed in the basement chiller room. Variable speed drives on the pumps will modulate the pumps to maintain a constant piping system differential pressure.

- Primary Pumps: Taco FI Series Model 4013D end suction pump with a 40HP motor and rated for 730 gpm at 130 feet of head pressure.

Chilled water supply and return piping will be replaced in the basement chiller room. Piping, valves, and trim will be replaced. A bladder type expansion tank and coalescing type air

separator will be provided. Existing makeup water piping will be reconnected to the chilled water piping. New 6-inch chilled supply and return piping will connect to the existing 6-inch chilled water supply and return riser and 4-inch chilled water supply and return branch piping in the chiller room.

New 6-inch diameter chilled water supply and return piping will be provided for connecting to a temporary air-cooled chiller.

- Chilled water piping will be Schedule 40 ASTM A53 steel with mechanical couplings.

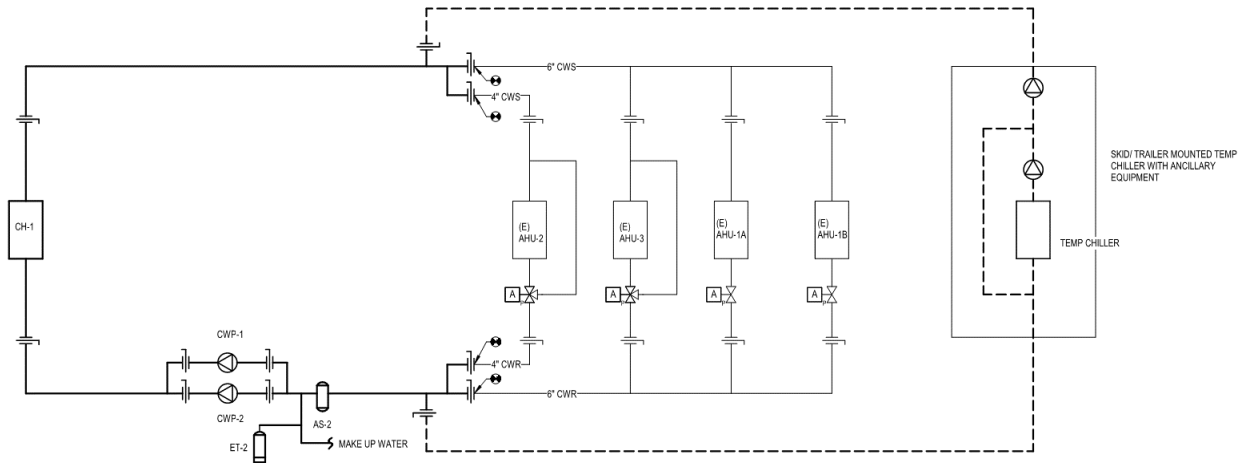

Figure 3 Richardson Hall Chilled Water Diagram

Cooling towers

The existing cooling towers on the roof of the adjacent Peavy Hall will remain.

Condenser Water Distribution

The condenser water piping system will be replaced within the Richardson Hall chiller room. Condenser water piping connecting to the Peavy Hall condenser water system will remain. See Figure 4 below.

Two base-mounted condenser water pumps will be provided for redundancy. Each pump is rated at the design flow rate through the chiller. Condenser water will operate at a constant flow through the chiller.

- Condenser Water Pumps: Taco TC Series Model 080510 double suction pump with a 25 HP motor and rated for 1,130 gpm at 50 feet of head pressure.

The 8-inch diameter condenser water supply and return piping will be replaced throughout the Richardson Hall chiller room. New 8-inch condenser water supply and return piping will connect to the existing piping at the north wall of the chiller room.

- Piping will be Schedule 40 ASTM A53 steel with mechanical joints.

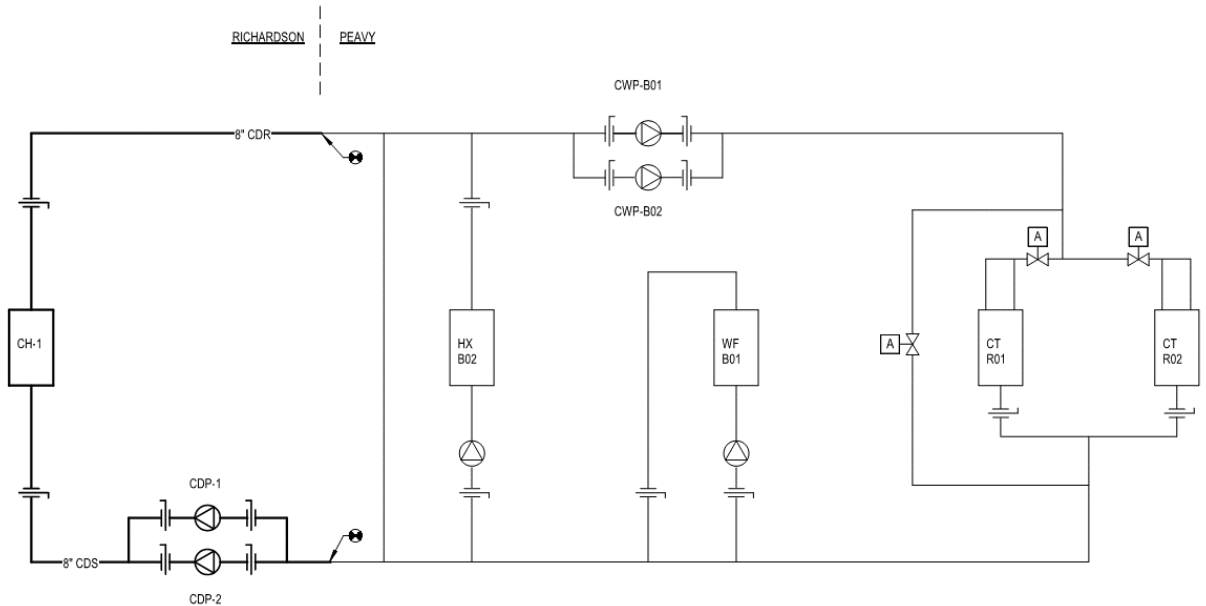

Figure 4 Richardson/Peavy Hall Condenser Water System

Refrigerant Exhaust System

The existing refrigerant monitoring system will remain. The system is capable of detecting R134A refrigerant and is connected to the building automation system for providing alarm, chiller plant shutdown, room exhaust and open makeup air louvers.

The installation of the chiller will require 3,500 cfm of emergency exhaust airflow. Inline exhaust fan EF-13 can be replaced with a new utility exhaust fan located outdoors in the equipment yard. The exhaust fan discharge will be located 20' away from the building openings and more than 7' above grade per Oregon Specialty Mechanical Code (OSMC)

- Emergency Refrigerant Exhaust Fan EF-13: Greenheck USF-16 upblast fan with 3,500 cfm airflow capacity at 1.5-inch external static pressure.

Controls

The chilled water system will be connected to the new Siemens building automation system. Automatic control system will include the following elements:

- Chiller operation is controlled by a self-contained packaged control system. The primary chilled water pumps and condenser water pumps will be interlocked with the chiller control panel.
- Primary chilled water pump speed is controlled to maintain pressure differential in the chilled water piping.
- Revise sequence of operations to turn on the chiller plant whenever the chilled water valve is more than 30% open for more than 10 minutes or outside air temperature is greater than 55°F.

Chiller Plant Scope of Work

- Demolish chiller CH-1.
- Demolish chilled water pumps CWP-1, CWP-2, and CWP-3.
- Demolish chiller concrete footing.

- Demolish refrigerant relief piping.
- Flush chilled water piping. Reconnect sand filtration system.
- Provide chilled water supply and return piping branch connections with isolation valves for connection to a temporary chiller.
- Provide a 6-inch-thick concrete equipment pad sized to accommodate the new chiller.
- Provide a new 400-ton magnetic bearing chiller.
- Provide two end suction primary chilled water pumps.
- Provide two double suction condenser water pumps.
- Provide new 6-inch chilled water supply and return piping in chiller room. Connect to existing 6-inch and 4-inch branches.
- Provide new 8-inch condenser water supply and return piping in chiller room. Connect to existing 8-inch piping.
- Provide manual butterfly valves on chilled water supply, chilled water return, condenser water supply and condenser water return connections to the chiller, and pumps.
- Provide temperature gauge, pressure gauge, and PT port on each chilled water and condenser water piping connection to the chiller.
- Provide refrigerant relief piping from the chiller to discharge outdoors 20 feet away from openings and 15 feet above grade.
- Connect chiller control panel to building automation system.
- Provide new controls and sequence of operations for the chiller plant.
- Demolish and replace existing EF-13 with a new utility fan outdoors. Revise exhaust ductwork and provide exhaust inlet near the floor.
- Replace automatic damper on the exterior wall to allow for emergency makeup air.

Electrical

The existing chilled water plant will be demolished and replaced with a new chiller capable of operating at reduced capacities to meet the building load. The existing electrical connections for this chiller plant and auxiliary pumps will be removed and new electrical installed for the new chiller and pump loads.

Following is a description of electrical work for the Richardson Hall Chiller Plant upgrades:

- New chiller CH-1 will re-use the existing 600-amp, 3-pole circuit breaker in existing switchboard MDH. New parallel sets of 350kcmil conductors will be installed in existing 2-1/2-inch conduits. New flexible conduits will be extended to new chiller controller location. Existing low voltage instrumentation conductors will be reinstalled in the new chiller controller.
- New primary chilled water pump CH-1 will require a new 15-amp, 3-pole circuit breaker in circuits 19,21,23 in existing panel BHM. Provide new conductors and conduit to new VFD location and connect complete. Provide new conductors and conduit from VFD to CH-1 pump location and connect complete.
- New secondary chilled water pump CH-2 will require a new 20-amp, 3-pole circuit breaker in circuits 13,15,17 in existing panel BHM. Provide new conductors and conduit to new

starter location and connect complete. Provide new conductors and conduit from starter to CH-2 pump location and connect complete.

- New chilled water pump CH-3 will be connected to existing 30-amp, 3-pole circuit breaker in circuits 26,28,30 in existing panel BHM. Provide new conductors and conduit to new VFD location and connect complete. Provide new conductors and conduit from VFD to CH-3 pump location and connect complete
- New condenser water pump CWP-1 will require a new 10-amp, 3-pole circuit breaker in circuits 7,9,11 in existing panel BHM. Provide new conductors and conduit to new VFD location and connect complete. Provide new conductors and conduit from VFD to CWP-1 pump location and connect complete
- New refrigerant exhaust fan EF-13 will require a new 15-amp, 3-pole circuit breaker in circuits 7,9,11 in existing panel EBH. Provide new conductors and conduit to new EF-13 location and connect complete.
- New 120-volt, 1-phase circuit will be fed to the new CH-1 controller. This circuit will be fed from an existing spare 20 amp, 1-pole circuit breaker in location 36 in existing panel BL located in the main electrical room adjacent to the chiller room.

Estimate of Probable Direct Construction Cost

Estimates of probable direct construction costs have been derived from trade cost estimating manuals and experience on past projects. No design work was performed in preparing the estimates. The estimates are intended to represent the direct construction cost that would be obtained from a public bid and, as such, do not include costs for professional services, permits, owner’s administration costs, and construction contingencies. Allocations for these costs should be added to the estimates of probable construction cost shown below. The estimates include the following additional estimating parameters:

- General contractor mark-up: 12%. It is assumed that a general contractor will be the prime contractor.
- Insurance, bonds, general conditions: 10%
- Escalation factor: 4% based on a one-year duration to a bid date.

| PROJECT COST SUMMARY | PROBABLE DIRECT CONSTRUCTION COST |
|--------------------------------|-----------------------------------|
| Architectural | \$10,000 |
| HVAC | \$475,000 |
| Electrical | \$40,000 |
| Subtotal | \$525,000 |
| Design Contingency (5%) | \$26,250 |
| Construction Contingency (10%) | \$52,500 |
| Construction Scope Subtotal | \$603,750 |
| General Conditions Noted Above | \$156,975 |
| Project Total | \$760,725 |

WOOD TREATMENT LAB 197B

Existing Conditions

Fire Sprinkler

A wet sprinkler system provides fire protection to Room 197B. The system is connected to the first-floor sprinkler zone control valve in Plumbing Room 164.

The wet sprinkler system is connected to a dry fire sprinkler riser in the adjacent Kiln Room. Dry fire sprinkler piping passes through Room 197B to serve the bicycle canopy area to the south.

Notable Conditions:

- The sprinklers appear to be spaced for an ordinary hazard classification.

Plumbing

A 3/4-inch domestic cold-water service enters the east side of the Kiln Room from Richardson Hall and extends to and through Room 197B. The cold water supplies an emergency eyewash near the sink at the southeast corner of the room and serves a hose bibb at the southwest corner of the room. The CW line drops down below the floor and connects to hose bibbs outdoors.

A 3/4-inch lab cold water and 3/4-inch lab hot water enters Room 197B from the east. Lab cold water and lab hot water serve a lab sink in the southeast corner of Room 197B.

A 2-inch vent from the lab sink is exposed and routed up the southeast corner of the room through the roof above.

A 3-inch waste line under the slab connects to the 2-inch drain from the lab sink and to a 3-inch floor drain.

There is a 3-inch floor drain in the southwest side of the room.

Notable Conditions:

- There is no existing emergency shower present Room 197B.

HVAC

One heating/ventilating unit serves the Kiln Room and Room 197B. An exposed duct with duct-mounted grilles provides airflow to each space. Both spaces are exhausted through an inline exhaust fan and louver located in Room 197B. A relief damper located in Room 197B provides relief for outside air.

Heating/Ventilating Unit: The heating/ventilating unit (HVVU-1) has a capacity of 8,700 cfm. The unit consists of outside air and return air mixing dampers, air filters, hot water heating coil, and supply fan. Air is supplied to each space through an exposed duct along the south wall with duct-mounted supply grilles. The air handling unit provides a minimum of 300 cfm of outside air.

Exhaust System: One 10,000 cfm in-line exhaust fan (EF-7) exhausts the Kiln Room and Room 197B. The fan is connected to duct-mounted grilles in Room 197B (2,000 cfm) and the Kiln Room (8,000 cfm). One exhaust louver is located on the south wall of Room 197B. Two

process exhaust blowers are ducted to the exhaust plenum. The exhaust louver has an isolation damper with a pneumatic actuator mounted exterior to the plenum.

Relief Louver: One relief louver provides general space pressure control. The relief louver is not ducted and is located on the west wall of the space, adjacent to the exhaust louver. The louver has an isolation damper with a pneumatic actuator mounted exterior to the damper. Relief air is transferred to the relief louver through the open doorway leading from the Kiln Room to Room 197B.

Notable Conditions:

- HVU-1 and EF-7 units operate on an occupied/unoccupied schedule.
- Outside Ventilation and Economizer Cooling: Outside air and return air dampers provide a mixture of return and outside air for ventilation and outside air cooling. The outside air intake and ducts are sized to provide 100% of the total supply airflow when operating in full economizer mode. The air handler heating coils are not sized for this amount of outside air flow.
- The heating coil is set to deliver a leaving air temperature of 80°F at a 65°F entering air temperature. This represents a minimum of 300 cfm of outside air at 22°F and 8,400 cfm of return air at 8,400 cfm.
- The heating/ventilating unit hot water coil is not capable of supplying sufficient heat at greater than 300 cfm of outside air during design heating conditions.
- Ductwork within the room is galvanized steel.
- The exhaust fan is in generally good condition and is suitable for reuse; however, it is currently located in Room 197B.
- The equipment and components in Room 197B do not appear to be rated for a Class I, Division 2 environment.
- The exhaust and relief damper actuators are pneumatically operated and may not be suitable for a Class I, Division 2 environment.

Steam Piping

Existing low pressure steam piping is routed across the Kiln Room into Room 197B.

Notable Conditions:

- Low-pressure steam piping drops down the north wall of Room 197B and is capped.

Electrical

Existing electrical devices in Room 197B are fed from existing panel 1LJ2, located in Kiln Room, existing panel 1LJ3 located in Kiln Room, and existing panel BMH, located in the basement main electrical room. Existing panel 1LJJ2 is 225-amp, 208/120 volt, 3-phase, 4-wire, and is fed from a 200-amp, 3-pole circuit breaker in existing panel 1LJ1. Existing panel 1LJ3 is 225-amp, 208/120 volt, 3-phase, 4-wire and is fed from a 100-amp, 3-pole circuit breaker in existing panel 1LJ1. See above for existing information on existing panel BHM.

The south wall of Room 197B contains one existing duplex receptacle connected to existing panel 1LJ2 circuit 4, one low voltage outlet with two jacks, and one fire alarm pull station. All of these

are surface mounted adjacent to the exit door at approximately 40" above finished floor. All of these are fed with surface mounted EMT conduit through the concrete floor.

The east wall of Room 197B contains two duplex receptacles connected to existing panel 1LJ2 circuit 4. Both are surface mounted at approximately 18" above finished floor. They are fed with surface-mounted EMT conduit through the concrete floor.

The north wall of Room 197B contains two empty boxes, one possibly for power, the other assumably for low voltage. Both are surface mounted at approximately 18" above finished floor and are fed with surface mounted EMT conduit through the concrete floor.

The west wall contains the following equipment:

- Two 480-volt, 30-amp, 3-pole, L16-30R receptacles fed from circuits 25,27,29 in existing panel BHM. There is one Conex container to the south of this room in the exterior yard that has a long flexible cord that plugs into one of these receptacles. Both are surface mounted at approximately 40" above finished floor and are fed with surface-mounted conduit that is routed overhead through the east wall of this room and into the Kiln Room. It enters the concrete floor adjacent to existing panel 1LJ3.
- Three 208-volt, 20-amp, 3-pole, L15-20 receptacles fed from 20 amp, 3-pole circuit breakers in circuits 1,3,5 and 7,9,11 and 13,15,17 in existing panel 1LJ3. Both are surface mounted at approximately 40" above finished floor and are fed with surface-mounted conduit that is routed overhead through the east wall of this room and into the Kiln Room, terminating in existing panel 1J3.
- One double duplex receptacle fed from circuit 14 in existing panel 1LJ3. This receptacle is possibly switched since a switch is mounted adjacent to the receptacle. Both are surface mounted at approximately 40" above finished floor and are fed with surface-mounted conduit that is routed overhead through the east wall of this room and into the Kiln Room, terminating in existing panel 1J3.
- Existing switch controlled duplex receptacle fed from circuit 6 in existing panel 1LJ2. The duplex receptacle is surface mounted at approximately 96" above finished floor. The switch is surface mounted at approximately 40" above finished floor. These are fed with surface-mounted conduit that is routed overhead through the east wall of this room and into the Kiln Room, terminating in existing panel 1J2. It appears that two small exhaust fans are plugged into this receptacle.
- One existing duplex receptacle connected to existing panel 1LJ2 circuit 4 and one low voltage outlet with two jacks. Both are surface mounted at approximately 18" above finished floor and are fed with surface mounted EMT conduit through the concrete floor. One low voltage data jack has a POE extender connected to it that appears to have a cable that runs through the south wall to the exterior and connecting to an antenna on top of the wood storage area. Circuit 4 from panel 1LJ2 continues in EMT conduit through the west wall and terminates on a junction box for heat trace in the covered wood storage area.
- Existing circuit 12 from panel BH located in the basement main electrical room routes overhead into a surface mounted junction box at approximately 96" above finished floor. This circuit appears to go through this wall and connect to the bike cover lighting fixtures.
- Existing exhaust fan EF-7 disconnect switch fed from circuits 26,28,30 in existing panel 3HMA. This switch is surface mounted at approximately 40" above finished floor and are fed with surface mounted EMT conduit through the concrete floor. Surface mounted conduit is routed from disconnect switch to EF-7 location at roof level.

- Existing lighting is 4-foot strip fixtures with two T8 lamps per fixture.

Existing lighting in Room 197B consists of two 8-foot industrial strip fixtures chain suspended from the ceiling. Each fixture has four T8 fluorescent lamps.

Systems Descriptions

Fire Sprinkler System

Reconfigure the sprinkler system in Room 197B in accordance with NFPA 13 requirements for extra hazard occupancy. Sprinklers will be exposed upright heads.

Plumbing

Provide an emergency shower/eyewash fixture. Extend a 1-1/4-inch tepid water line and 3/4-inch recirc line from the existing tepid water system on the first-floor lab wing.

- Demolish unneeded fixtures and associated piping back to the last active service.

HVAC

The required exhaust for the room exceeds the makeup air capacity of the existing heating/ventilating unit and requires continuous ventilation. A 1,400-cfm makeup air fan coil unit will need to be provided to serve Room 197B. Hot water supply and return piping will be extended from the mechanical mezzanine to the fan coil unit. The fan coil unit will be located in the Kiln Room and will be ducted to an outside air intake on the roof. The supply duct will be routed through the existing supply duct opening in the room.

- Mechanical cooling will not be provided.

To allow dedicated ventilation, a 1,500-cfm roof-mounted exhaust fan with a discharge stack will be installed on the roof above Room 197B. The fan will be connected to a vertical aluminum duct located in a corner of the room with both high and low exhaust grilles.

The galvanized supply and exhaust ductwork within the room is not compatible with the chemicals in the space and should be replaced with aluminum.

The existing exhaust louver and relief louver may remain in place; however, the addition of doors to Room 197B will block the relief air path to the relief louver. An aluminum duct will need to be connected to the relief louver and extended to the Kiln Room through the east wall of Room 197B. A fire/smoke damper will be required at the duct penetration.

The fire/smoke damper must be installed in the supply duct and exhaust duct at the interior wall penetrations.

The process exhaust fans connecting to the exhaust plenum should be demolished.

The exhaust fan is not rated to be installed in a Class I, Division 2 environment and needs to be relocated to the adjacent room to the north.

Steam

The steam piping in Room 197B should be demolished back to the last active service in the Kiln Room.

Controls

The pneumatic damper actuators need to be replaced with Class I, Division 2-rated electronic actuators.

The exhaust fan and makeup air fan coil will operate continuously to provide ventilation to the space.

An emergency shutoff for the fan coil and exhaust fan will be provided.

The exhaust fan, makeup air fan coil, heating coil valve, relief damper, and exhaust damper will be connected to the existing Siemens DDC system. A Class I, Division 2 thermostat will be provided in Room 197B to maintain space temperature set point.

Electrical

Room 197B contains a wood treatment process that requires it to be treated as a hazardous Class I Division II space per the National Electrical Code. As stated in the existing conditions previously in this report, there are numerous items that need to be addressed to bring this room up to current Code.

In general, new conduit homeruns will be installed for all devices, luminaries, and equipment in Room 197B. All conduits shall be RGS. All receptacles, switches, disconnects, starters, and fire alarm devices shall be UL listed for Class 1 Division 2 locations. Conduit seal-offs will be provided as required by Code. Room 197B will be physically separated from Room 197. This will include sealing off the doors/openings between the two rooms, including all penetrations for utilities.

South Wall

- The existing duplex receptacle and existing branch circuit conductors will be removed, and existing conduit cut and capped at the existing concrete floor. Install a new duplex receptacle at 48" to bottom of device. Install new ¾-inch RGS conduit from receptacle, up the wall to 9' above finished floor, routed through the east wall and terminated in Panel 1LJ2. Install new conductors from existing circuit breaker 4 to receptacle. Provide sealant in the wall penetration to maintain existing wall rating.
- The existing low voltage outlet will be removed, and conduit cut and capped at the existing concrete floor. It appears that the two jacks in this outlet are not operational; therefore, a new outlet will not be provided.
- The existing fire alarm pull station will be removed and relocated adjacent to the exterior door at 48" to bottom of device. Existing surface mounted conduit will be removed and replaced with RGS conduit with seal off device. Existing fire alarm cable shall be removed, and new cable installed.

East Wall

- Existing two duplex receptacles and existing branch circuit conductors will be removed, and existing conduit cut and capped at the existing concrete floor. Install new duplex receptacles at 48" to bottom of devices. Install new RGS conduit from receptacles, up the wall to 9' above finished floor and terminate in a new conduit for the branch circuit conduit to duplex receptacle on the south wall. Install new conductors so both duplex receptacles are connected to circuit 4 in existing panel 1LJ2.

North Wall

- Two existing empty boxes and existing pull string will be removed, and existing conduits cut and capped at the existing concrete floor.

West Wall

- Existing two 480-volt, 30 amp, 3-pole, L16-30 receptacles will be removed, pull back existing branch circuit conductors from 30-amp, 3-pole circuit breaker 25,27,29 in existing panel BHM will be re-used. Remove existing conduit from Room 197B. Re-install one 480-volt, 30 amp, 3-pole, L16-30 receptacle adjacent to Panel 1LJ3 at 48" above finished floor and re-connect existing branch circuit conductors. Route flexible cord and plug through south wall of the Kiln Room above re-installed receptacle and connect the plug to the receptacle. Provide sealant in wall penetration to maintain existing wall rating and weatherproof.
- Existing three 208-volt, 20 amp, 3-pole, L15-20 receptacles fed from 20 amp, 3-pole circuit breakers in circuits 1,3,5 and 7,9,11 and 13,15,17 in existing panel 1LJ3 will be removed. Remove existing conductors back to panel 1LJ3 and remove all conduit associated with these branch circuits. Revise panel schedule for panel 1LJ3 to indicate spare for these circuit breakers.
- Existing double duplex receptacle, existing branch circuit conductors, and existing conduit will be removed. Install a new double duplex receptacle at 48" to bottom of device. Install new ¾-inch RGS conduit from receptacle, up wall to 9' above finished floor, routed through east wall, and terminated in Panel 1LJ23. Install new conductors from existing circuit breaker 14 to receptacle. Provide sealant in wall penetration to maintain existing wall rating. Relocate existing switch to same elevation as double duplex receptacle.
- Existing switch controlled duplex receptacle mounted at 96" above finished floor and switch to be removed, existing branch circuit conductors from Panel 1LJ2 circuit 6 to be removed and remove all conduit.
- Existing duplex receptacle and existing branch circuit conductors will be removed, and existing conduit cut and capped at the existing concrete floor. Install new duplex receptacle at 48" to bottom of devices. Install new RGS conduit from receptacle, up wall to 9' above finished floor, and terminate in duplex receptacle on the south wall. Install new conductors so duplex receptacle is connected to circuit 4 in existing panel 1LJ2. Remove existing conduit and conductors to heat trace junction box in the wood storage area. Provide new 20 amp, 1-pole circuit breaker in position 22 in existing panel 1LJ3 and install new conduit and conductors to heat trace junction box. Existing low voltage outlet will be removed, existing cables removed, and conduit cut and capped at the existing concrete floor. Install new low voltage outlet with two data jacks on the south wall of the Kiln Room adjacent to Panel 1LJ3. Install two new CAT5E cables from the first-floor data room to new jacks and connect. Install existing POE injector and cable from existing antennae to this outlet.
- Existing branch circuit conductors from existing panel BH circuit 12 will be removed. Intercept existing conduit outside of Room 197B and provide new conduit to the bike cover light fixtures. Provide new branch circuit conductors.
- Existing exhaust fan EF-7 disconnect switch and existing EF-7 will be removed. Remove existing branch circuit conductors. Remove existing conduits from room. Label circuit breaker in Panel 3HMA circuits 26,28,30 as spare. See below for new connection.

New equipment installed inside Room 197B will be connected to existing panels as described below.

- Hood is listed as 120-volt, 1-phase and will plug into an available duplex receptacle in the room.
- Vacuum pump is listed at 0.4HP, 120-volt, 1-phase and will plug into an available duplex receptacle in the room.
- Compressor is listed at 5HP, 208-volt, 3-phase. Provide new 20-amp, 3-pole circuit breaker in existing panel 1LJ3 in spaces 22,24,26.
- Boiler is listed at 34kW, 480-volt, 3-phase. Provide new 50-amp circuit breaker in existing panel 3HMA.

New equipment installed outside of Room 197B will be connected to existing panels as described below.

- Fan coil is listed at (2) 0.5HP, 208-volt, 1-phase. Provide new 15-amp, 2-pole circuit breaker in existing panel 1LJ3 in spaces 23,25.
- Exhaust Fan EF-7 is listed at 3HP, 480-volt, 3-phase. This will be connected to emergency power, existing panel E3HM. Provide new 20-amp, 3-pole circuit breaker.
- Two fire smoke dampers are listed at 120V, 1-phase. Connect to existing circuit previously used for the existing fire smoke dampers.
- Exhaust Fan EF-19 is listed at 1HP, 277-volt, 1-phase. Connect to new 20-amp, 1-pole circuit breaker in existing panel E3HM.

Existing light fixtures, existing branch circuit conductors, and existing conduit will be removed from Room 197B. Provide three 8-foot, LED light fixtures rated for Class I Division II applications. Chain hang lights at 10' above finished floor. Install new RGS conduit from existing conduit location in the Kiln Room to new light fixtures. Install new branch circuit conductors. Install a new light fixture switch in the Kiln Room adjacent to access door to Room 197B.

Architectural

Treatment Process Considerations

The extent of renovation required by building code to Room 197B in Richardson Hall to accommodate the relocation of the wood treatment equipment from the Oak Creek Building will be driven primarily by the use and quantities of the treatment chemicals. Building Code dictates maximum allowable quantities (MAQ) of hazardous materials used or stored within buildings and spaces. Hazards can include toxicity, flammability, etc. and many of the chemicals that will be used in the wood treatment process will be restricted to some degree by these code requirements. The following is a summary of the proposed chemical use and storage:

Treatment Chemical Use/Storage

- Treatment in the space will occur with one treatment solution at a time.
- Each treatment solution that is used in the equipment will be in 55-gallon drums. The equipment uses approximately two drums, but there may be a third drum on hand for any given treatment process. This means there will be 165 gallons of treatment solution in the room.

- The treatment solution is pumped from the drums into the treatment equipment (70-gallon storage vessel) in a closed loop. It is then pumped back into the storage drums at the end of the process in a closed loop.
- In the treatment process, a treatment cylinder is opened, the wood is inserted into the cylinder, and the cylinder is sealed. Then the equipment pumps the chemical from the 70-gallon storage tank into the cylinder under pressure to treat the wood. The chemical is then pumped back to the storage tank and the cylinder is opened for wood removal.
- Just after treatment the open cylinder is devoid of most chemical but there still is some coating the sides of the cylinder and the chemical is not yet dried onto the surface of the wood. The wood is allowed to drip dry within the room. Some lower molecular weight components of the solutions are volatile during this “drying” process.
- Some of the proposed chemicals are ready-to-use solutions. Other treatment chemicals will be brought into the room as concentrates and must be added within the room to a solvent prior to use in the equipment. The proposed use of the following chemicals is in the basis for the architectural scope assumptions (MSDS attached):
- Treatment Solutions: (2-3) 55-gallon drums
 - CCA Treating Solution (Chromated Copper Arsenate)
 - Chemonite Treating Solution 1-15% (Ammoniacal Copper Zinc Arsenate)
 - Creosote P1/P13 (could be diluted 50:50 with hydrocarbon solvent)
- Concentrates: (1-2) 5-gallon containers
 - UP-23 Work Solution with Biodiesel (DCOI:4,5-Dichloro-2-n-octyl-4-isothiazolin-3-one)
 - Tenino Copper Napthenate (in solvent Mineral/Oil Spirits)
 - Dura-Treat 40 Wood Preserver (Pentachlorophenol)
- Solvents: (2-3) 55-gallon drums
 - Diesel Fuel
 - Petroleum Distillate (Bunker Oil)
 - Hydrocarbon Solvent, Type A (heavy oil)
 - Hydrocarbon Solvent, Type C (light oil)

Code Classification

When chemicals are present in quantities that are above the listed MAQ limits for a given hazard class, the room must be designated as an H-occupancy space. Various construction and detailing requirements apply to H-occupancy Rooms depending on the H-occupancy classification which relates to the type and hazard of the chemicals present. A cursory assessment of the proposed chemicals list and the manner in which these chemicals are stored and used has informed the initial classifications indicated below. Note that this cursory assessment did not take into account any other rooms on the same floor that may be within the same chemical control area to which the MAQ applies. An in-depth chemical analysis is recommended during design of the renovation to confirm these assumptions.

H-4 Occupancy (Health Hazards)

At least two chemicals with potential health hazards (CCA and Chemonite) will be present in quantities above the listed MAQ for that hazard class. The room will need to meet the building code requirements for H-4 classification.

Although it is understood that these particular chemicals may be phasing out of the industry, they are an important representation of higher toxicity chemicals that may be tested over the life of the facility.

H-3 Occupancy (Physical Hazards)

Chemicals that could present explosion or fire hazards appear to be within MAQ limits. H-3 occupancy designation should not be required.

NEC Class1, Division 2

The type and use of the chemicals does not appear to produce significant amounts hazardous vapors.; however, there will be some off-gassing of low molecular weight components of the solutions and solvents as the chemicals are allowed to dry on the wood samples in the open atmosphere of the room. The presence of these minor vapors warrants NEC Class 1, Division 2 classification for electrical components. Refer to the electrical scope summary for more information.

Architectural

The H-4 building code requirements are less restrictive than H-3. No explosion control, etc., but several of the other typical H-occupancy provisions will be required:

- Spill containment: This will apply to the wood treatment equipment area as well as a designated area within the room where the 55-gallon drums will be placed. An area defined by a concrete curb will likely suffice. However, for the drum storage area ramps will be required for material transfer over the curb.
- Rated separation (1-hour): 1-hour rated construction will be required between this Room and the surrounding building. The existing 8-inch masonry wall is likely to meet a calculated 1-hour rating. Additional information regarding the masonry units and detailing will be required to confirm this during design. A one-sided gypsum wall assembly can also be easily added to the interior of the room if determined necessary to provide a 1-hour rating independently from the existing wall. Currently openings and penetrations (ducts and piping) through the room perimeter are not detailed in a manner to achieve a 1-hour rating. These penetrations and openings will have to be revised accordingly.
- Emergency power for ventilation, etc., may be required if not currently available in the building. See electrical summary.
- Higher density sprinkler heads will likely be required. This will also include assessment of the main distribution and the water flow to verify compatibility with the higher demand. See mechanical summary.

Beyond curbs for spill containment and wall and door improvements to create a 1-hour separation at the perimeter of the room, the architectural scope is limited. The following additional assumptions are included in the preliminary budgeting:

- Interior door replacement
- Addition of chemical safety shower and eyewash
- Minor revisions to Room signage (match to existing building)

- Interior paint (if gypsum wall assembly is installed)
- No flooring (existing exposed concrete slab)
- No ceilings (existing open to structure)
- Minor hardware modifications to exterior door (see Electrical for Access Control)
- Minor roof modifications for HVAC outdoor unit/fan supports and/or penetrations
- No exterior improvements

Estimate of Probable Direct Construction Cost

Estimates of probable direct construction costs have been derived from trade cost estimating manuals and experience on past projects. No design work was performed in preparing the estimates. The estimates are intended to represent the direct construction cost that would be obtained from a public bid and, as such, do not include costs for professional services, permits, owner’s administration costs, and construction contingencies. Allocations for these costs should be added to the estimates of probable construction cost shown below. The estimates include the following additional estimating parameters:

- General contractor mark-up: 12%. It is assumed that a general contractor will be the prime contractor.
- Insurance, bonds, general conditions: 10%
- Escalation factor: 4% based on a one-year duration to a bid date.

| PROJECT COST SUMMARY | PROBABLE DIRECT CONSTRUCTION COST |
|--------------------------------|-----------------------------------|
| Architectural | \$36,000 |
| Mechanical | \$124,000 |
| Fire Protection | \$20,000 |
| Electrical | \$55,000 |
| Subtotal | \$235,000 |
| Design Contingency (5%) | \$11,750 |
| Construction Contingency (10%) | \$23,500 |
| Construction Scope Subtotal | \$270,250 |
| General Conditions Noted Above | \$70,265 |
| Project Total | \$340,515 |

CONTROLS REPLACEMENT AND UPGRADE

Existing Conditions

The following is a description of the existing HVAC control systems at Richardson Hall along with notable conditions observed during an on-site field survey.

The building automation controls consist of a Phoenix pneumatic system for lab airflow controls and a Siemens MBC DDC system for the heating, cooling, ventilation, and plumbing controls.

Siemens DDC System

The Siemens DDC system consists of seven MBC controllers and many TECs for terminal units, reheat coils, fan coil units, etc. There are several pneumatic valve and damper actuators that are controlled by the Siemens system including:

- Lab Exhaust System (EF-1A, EF-1B, EF-1C, EF-1D, EF-1E)
 - Exhaust fan damper actuators
 - Lab exhaust heat recovery coil bypass damper actuator
- Lab Supply System (SF-1 and SF-2)
 - Outside air damper actuators
 - Smoke/isolation damper actuators
 - Heating and cooling coil control valve actuators
- Office Air Handling System (AHU-2 and AHU-3)
 - Outside air, exhaust, return, and supply air damper actuators
 - Heating and cooling coil control valve actuators
- AHU-4 and AHU-5
 - Outside air, supply, and exhaust damper actuators
 - Heating and cooling coil control valve actuators
- HVU-1 and HVU-2
 - Outside air, return, and relief damper actuators
 - Heating coil control valve actuator
- Steam service control valve actuators to the steam to hot water converter (C-1)

Phoenix Lab Control System

The Phoenix Lab control system provides air pressure control for all lab spaces through pneumatically operated air valves.

The existing fume hoods are constant volume bypass type with airflow alarms and proximity sensors. The system was designed for variable volume control and the hoods were provided with a blank-off panel behind the bypass grille to allow for variable volume control.

Systems and devices still utilizing pneumatic controls include:

- Laboratory system controllers used to control all Phoenix air valves in labs (153 qty).

Notable Conditions:

- The pneumatic poly tubing is cracking and failing in multiple places.
- The current lab control system is 20+ years old and lacks reliability.
- The Siemens DDC system is 10+ years old and the TECs are unable to accommodate more points desired by the Owner, such as discharge air temperature on the terminal units and updated digital lab controls.
- Original fume hood proximity sensors are not in use. There is potential for energy savings by incorporating back in proximity sensors or sash height sensors.
- DDC control valves have been observed by the Owner to not close completely and some have been replaced.

Systems Descriptions

DDC System Upgrades

The outdated Siemens DDC controls system will be upgraded to current standards that will provide more reliability and versatility for controlling the building's systems. The updated PXCM controllers can be installed in the existing MBC controls enclosures.

Scope of the controls upgrade will include replacement of:

- Seven MBC controllers and expansions with PXCM controllers.
- Transition from MBC controllers to PXCM utilizing Siemen's Fast Forward ability to transfer programming.
- TECs with DXR BACNet IP Building Level Network
- Pneumatic actuators on control dampers and control valves with electronic actuators.
- Reheat control valves and actuators on 61 laboratory reheat coils and 63 terminal unit reheat coils
- Wiring between PXCM and DXR controllers
- Wiring from DXR to space temperature sensors utilizing existing pathways
- Space temperature sensors

Discharge air temperature sensors will be added downstream of all reheat coils and input to the DDC system.

Air handling unit devices and sensors will remain where functionality can be verified. Non-functional devices and sensors will be replaced.

Lab Airflow Control Upgrades

The replacement of the laboratory air valves and controls will require incorporating the new Phoenix Lab control points for airflow into the Siemens DDC system. This will require BACNet IP from Phoenix to Siemens, software configuration, and graphic development. Lab airflow control upgrades will include:

- Replacement of 153 Phoenix medium pressure laboratory air valves and their associated pneumatic controls.
- Replacement of fume hood airflow monitoring.
- Addition of fume hood sash position sensors.
- Verification of all fume hoods for variable flow operation.
- Removal of proximity sensors.
- Incorporation of occupied/unoccupied airflow rates with variable volume air valves for reduced energy consumption.
- Verification of pressure relationships for each space and rebalancing.

Estimate of Probable Direct Construction Cost

Estimates of probable direct construction costs have been derived from trade cost estimating manuals and experience on past projects. No design work was performed in preparing the estimates. The estimates are intended to represent the direct construction cost that would be obtained from a public bid and, as such, do not include costs for professional services, permits, owner’s administration costs, and construction contingencies. Allocations for these costs should be added to the estimates of probable construction cost shown below. The estimates include the following additional estimating parameters:

- General contractor mark-up: 12%. It is assumed that a general contractor will be the prime contractor.
- Insurance, bonds, general conditions: 10%
- Escalation factor: 4% based on a one-year duration to a bid date.

| PROJECT COST SUMMARY | PROBABLE DIRECT CONSTRUCTION COST |
|--------------------------------|-----------------------------------|
| Architectural | \$10,000 |
| DDC Controls | \$880,000 |
| Lab Airflow Controls | \$320,000 |
| HVAC | \$353,750 |
| Subtotal | \$1,563,750 |
| Design Contingency (5%) | \$78,200 |
| Construction Contingency (10%) | \$156,400 |
| Construction Scope Subtotal | \$1,798,350 |
| General Conditions Noted Above | \$467,600 |
| Project Total | \$2,265,950 |