



Oregon State University

INVITATION TO BID #198689

DIXON CHILLER REPLACEMENT – RE-BID

ISSUE DATE: March 20, 2019

ITB CLOSING (DUE) DATE: April 10, 2019 at 2:00 PM Pacific Time

MANDATORY PRE-BID CONFERENCE: March 29, 2019 at 2:00 PM Pacific Time in the Main Lobby of
Dixon Recreation Center at 425 SW 26th Street, Corvallis, OR 97331.

QUESTION DEADLINE: April 3, 2019 at 5:00 PM Pacific Time

PROJECT NUMBER: 2132-19

CONTRACT ADMINISTRATOR:

Matt Hausman, Construction Contract Officer

Construction Contract Administration

Oregon State University

644 SW 13th Ave.

Corvallis, OR 97333

Phone: (541) 737-3401

FAX: (541) 737-5546

Email: matt.hausman@oregonstate.edu

AWARD DECISION APPEALS:

Hanna Emerson, Construction Contracts Manager

Construction Contract Administration

Oregon State University

644 SW 13th Ave.

Corvallis, OR 97333

Phone: (541) 737-7342

FAX: (541) 737-5546

Email: hanna.emerson@oregonstate.edu

PROJECT MANUAL
TABLE OF CONTENTS

Notice of Opportunity
Instructions to Bidders
Bid Form
Sample OSU Retainer Contract Supplement
Performance Bond
Payment Bond
Oregon State University General Conditions for Retainer Contracts
MWESB Form Instructions
MWESB Form
BOLI Prevailing Wage Rate Notification

GENERAL REQUIREMENTS

Division 01 prepared by Oregon State University dated March 2019

Summary of Work	Section 01 11 00
Application for Payment	Section 01 24 76
Sample Contract Payment Request Form	
Continuation Sheet	
Product Substitution Procedures	Section 01 25 00
Sample Substitution Request Form	
Project Meetings	Section 01 31 19
Shop Drawings, Product Data, Samples	Section 01 33 23
Abbreviations and Symbols	Section 01 42 13
Definitions	Section 01 42 16
Reference Standards	Section 01 42 19
Quality Control	Section 01 45 00
Construction Facilities & Temporary Controls	Section 01 51 00
Construction and Maintenance Safety Requirements	
Construction and Maintenance Safety Form	
Construction and Maintenance Isolation Requirements	
Model Site Safety Plan	
Tree and Plant Protection	Section 01 56 39
Product Requirements	Section 01 60 00
Cutting and Patching	Section 01 73 29
Cleaning	Section 01 74 00
Contract Closeout	Section 01 77 00

TECHNICAL SPECIFICATIONS

Divisions 23 & 26 prepared by PAE dated March 14, 2019

Common Work Results for HVAC	Section 23 05 00
Variable Frequency Drives for HVAC Equipment	Section 23 05 14
HVAC Expansion Compensation	Section 23 05 18
Meters and Gauges for HVAC	Section 23 05 19
General Duty Valves and Specialties for HVAC	Section 23 05 23
Hangers and Supports for HVAC	Section 23 05 29
Vibration and Seismic Controls for HVAC Piping and Equipment	Section 23 05 48
Identification for HVAC Piping and Equipment	Section 23 05 53
Pressure Testing for HVAC Systems	Section 23 05 90
Testing, Adjusting and Balancing for HVAC	Section 23 05 93
Insulation for HVAC	Section 23 07 00
Commissioning	Section 23 08 00
Instrumentation and Controls for HVAC	Section 23 09 00
Pipe and Pipe Fittings HVAC	Section 23 21 13
Pumps for HVAC Systems	Section 23 21 23
HVAC Water Treatment	Section 23 25 00
Packaged Water Chillers	Section 23 64 00
Convection Heating and Cooling	Section 23 82 00
Common Work Results for Electrical	Section 26 05 00
Low Voltage Electrical Power Conductors and Cables	Section 26 05 19
Grounding and Bonding for Electrical Systems	Section 26 05 26
Hangers and Supports for Electrical Systems	Section 26 05 29
Raceways and Boxes for Electrical Systems	Section 26 05 33
Seismic Restraints for Electrical Raceways and Equipment	Section 26 05 45
Identification for Electrical Systems	Section 26 05 53
Overcurrent Protective Device Coordination Study	Section 26 05 73
Electrical Testing	Section 26 05 80

EXHIBIT 1

225 Ton Carrier Air-Cooled Screw Submittal

DRAWINGS

prepared by PAE dated March 15, 2019 – Available at the following:

<https://drive.google.com/drive/folders/1Q5e6mioW78xkwqsUBvhEri1gr-LL7wCm?usp=sharing>

END OF TABLE OF CONTENTS

OREGON STATE UNIVERSITY

NOTICE OF OPPORTUNITY – RETAINER INVITATION TO BID

DIXON CHILLER REPLACEMENT – RE-BID

Oregon State University (“Owner”) is accepting sealed bids from Contractors on the OSU Retainer list for a public improvement project at Construction Contracts Administration, Oregon State University, 644 SW 13th Ave., Corvallis, Oregon, until 2:00 PM local time, April 10, 2019 for the Dixon Chiller Replacement – Re-Bid project located on the campus of Oregon State University, Corvallis, Oregon.

A **MANDATORY PRE-BID CONFERENCE** and examination of the site and conditions will take place on March 29, 2019 at 2:00 PM Pacific Time in the Main Lobby of Dixon Recreation Center (425 SW 26th Street Corvallis, OR 97331). Attendance will be documented through a sign-in sheet prepared by the Owner’s Representative. Prime bidders who arrive more than 5 minutes after start time of the meeting or after the discussion portion of the meeting (whichever comes first) shall not be permitted to sign in and will not be permitted to submit a bid on the project.

Plans and specifications for this bid along with the Request for Qualifications for the 2018-2020 Construction Related Services Retainer are available at the following website: <https://bid.oregonstate.edu/>

All bidders must comply with requirements of the prevailing wage law in ORS 279C.800 through ORS 279C.870. All bidders must be registered with the Construction Contractor's Board at the time of bid submission. No bid will be considered unless fully completed in the manner provided in the "Instructions to Bidders" upon the Bid Form provided. OSU encourages bids from Minority, Women, and Emerging Small Businesses.

OREGON STATE UNIVERSITY

By:

BY: Matt Hausman

Construction Contracts Officer
Oregon State University

DATE OF POSTING:

Wednesday March 20, 2019

OREGON STATE UNIVERSITY

INSTRUCTIONS TO BIDDERS

Table of Contents

<u>Article</u>	<u>Title</u>
1.	Definitions
2.	Scope of Work
3.	Examination of Site and Conditions
4.	Substitute Materials Approval Process
5.	Interpretation of Project Manual
6.	Execution of the Bid Form
7.	Prohibition of Alterations to Bid
8.	Submission of Bid
9.	Bid Closing and Opening of Bids
10.	Acceptance or Rejection of Bids by Owner
11.	Withdrawal of Bid
12.	Execution of Contract, Agreement, Performance Bond and Payment Bond
13.	Recyclable Products

INSTRUCTIONS TO BIDDERS

OSU Standard Chapter 580, Divisions 61 and 63 govern this OSU procurement process.

Article 1. Definitions

1.1. Capitalized words used herein but not defined shall have the meaning set forth in the OSU General Conditions and OSU Standard 580-061-0010. The following terms used herein shall have the meaning set forth below:

“Bid Form”- refers to OSU form provided by Owner to be completed by Bidder.

“Project Manual”- The Project Manual includes, but is not necessarily limited to, the following: the Advertisement for Bids or Notice of Contracting Opportunity, these Instructions to Bidders, Supplemental Instructions to Bidders, Bid Form, Bid Bond, OSU General Conditions, Supplemental General Conditions (if any), Sample Supplement or Agreement, Performance Bond, Payment Bond, and the Plans and Specifications.

Article 2. Scope of Work

2.1 The Work contemplated in this document shall be for the Owner in connection with the Project described in the Project Manual.

Article 3. Examination of Site and Conditions

3.1 Before making a Bid, the Bidder shall examine the Work site to ascertain its physical condition. The Bidder shall be responsible for being fully informed as to the quality, quantity and sources of supply of the materials listed on the Project Manual. Failure to comply with this Section will not release Contractor from entering into the Contract nor excuse Contractor from performing the Work in strict accordance with the terms of the Contract Documents.

3.2 The Owner will not be responsible for any loss or unanticipated costs which may arise as a result of Contractor's failure to be fully informed in advance with regard to all conditions pertaining to the Work and the character of the Work required.

3.3. No statement made by any officer, agent, or employee of the Owner in relation to the physical conditions pertaining to the Work site or quality, quantity, and supply of materials will be binding on the Owner, unless included in writing in the Project Manual or an Addendum.

Article 4. Substitute Materials Approval Process

4.1 Prior to submitting a Bid including a Substitution, the Bidder must first seek approval of the Substitution from the Architect (or Engineer, as appropriate hereafter) by submitting a written request for approval at least 10 calendar days prior to the Closing Date and Time. The Bidder submitting the request shall be responsible for its timely delivery.

4.2 Substitution approval requests shall be accompanied by samples, records of performance, certified copies of tests by impartial and recognized laboratories, and such other information as the Architect may request.

4.3 Within a reasonable time after receiving such a request the Owner (or Architect if so designated) will consider whether the Substitution sought by Bidder is of equal value, utility, as the designated product in the Project Manual. If the requested Substitution is approved an Addendum to the Project Manual shall be issued. A copy of each Addendum shall become a part of the Project Manual.

4.4 When the Architect approves a Substitution by Addendum, it is with the understanding that the Contractor guarantees the substituted article or material to be equal or better than the one specified.

Article 5. Interpretation of Project Manual

5.1 A Bidder in doubt as to the meaning of any part of the Project Manual may submit a written request for an interpretation to the Architect at any time prior to 10 calendar days prior to the Closing Date and Time.

5.2 Any interpretation of the Project Manual will be made only by a duly issued Addendum. The Owner will not be responsible for any other explanation or interpretation of the Project Manual nor for any other approval of a particular manufacturer's process or item.

5.3 To establish a basis of quality, certain processes, types of machinery and equipment or kinds of materials may be specified in the Project Manual either by description of process or by designating a manufacturer by name and referring to a brand or product designation or by specifying a kind of material. Whenever a process is designated or a manufacturer named, brand or item designation given, or whenever a process or material covered by patent is designated or described, it shall be understood that the words "or approved equal" follow such name, designation or description, whether they do so or not.

Article 6. Execution of the Bid Form

6.1 The Bid Form relates to Bids on a specific Project Manual. Only the amounts and information asked for on the Bid Form furnished by the Owner will be considered as the Bid. Each Bidder shall Bid upon the Work exactly as set forth in the Bid Form. The Bidder shall include in the Bid a sum to cover the cost of all items contemplated by the Project Manual. Bids that fail to address alternates set forth on the Bid Form may be considered non-responsive.

6.2 Each Bid Form must: 1) Be completed in accordance with these instructions; 2) Include the appropriate signatures as noted on the Bid Form; 3) Include numbers pertaining to base Bids stated both in writing and in figures; and 4) Include the Bidder's typed or clearly printed address.

6.3 When Bidding on an alternate for which there is no charge, the Bidder shall write the words "No Charge" in the space provided on the Bid Form. If one or more alternates is shown on the Bid Form, the Bidder shall indicate whether each is "add" or "deduct."

Article 7. Prohibition of Alterations to Bid

7.1 Bids which are incomplete, or contain ambiguities or conditions not provided for in the Bid Form, may be rejected.

Article 8. Submission of Bid

8.1 Each Bid shall be sealed in an envelope, properly addressed to the appropriate project representative of the Owner, showing on the outside of the envelope the name of the Bidder and the name of the project. Bids will be received at the time and place stated in the Advertisement for Bids.

Article 9. Bid Closing and Opening of Bids

9.1 All Bids must be received by the Owner before the Closing Date and Time. Any Bids received after the Closing Date and Time will be rejected and returned to the Bidder unopened.

9.2 At the time of opening and reading of Bids, each Bid received, irrespective of any irregularities or informalities, will be publicly opened and read aloud.

Article 10. Acceptance or Rejection of Bids by Owner

10.1 Unless all Bids are rejected, the Owner will award the Contract based on the lowest responsive Bid from a responsible Bidder. If that Bidder does not execute the Contract, the Contract will be awarded to the next lowest responsible Bidder or Bidders in succession.

10.2 The procedures for Contract awards shall be in compliance with the provisions of OSU Standards adopted by the Owner.

10.3 The Owner reserves the right to reject all Bids and to waive minor informalities.

10.4 The Owner reserves the right to hold the Bid and any required Bid security, of the three lowest Bidders for a period of 30 calendar days from the time of Bid opening pending award of the Contract. Following award of the Contract, any Bid security furnished by the three lowest Bidders may be held 20 calendar days pending execution of the Contract. All other Bids will be rejected and Bid security returned.

10.5 In determining the lowest Bidder, the Owner reserves the right to take into consideration any or all authorized base Bids as well as alternates or combinations indicated in the Bid Form.

10.6 If Owner has not accepted a Bid within 30 calendar days after the opening of the Bids, each of the three lowest Bidders may withdraw the Bid submitted and request the return of any Bid security then held.

Article 11. Withdrawal of Bid

11.1 At any time prior to the Closing Date and Time a Bidder may withdraw its Bid. This will not preclude the submission of another Bid by such Bidder prior to the Closing Date and Time.

11.2 After the Closing Date and Time, no Bidder will be permitted to withdraw its Bid within the time period specified in Article 10 for award and execution, except as provided for in that Article.

Article 12. Execution of Contract, Agreement, Performance Bond and Payment Bond

12.1 The Owner will provide the successful Bidder with Contract Documents within 10 calendar days after the award of the Contract. The Bidder shall be required to execute the Contract as provided, including a Performance Bond and a Payment Bond from a surety company licensed to do surety business in the State of Oregon, within 20 calendar days after the award of the Contract. The Contract Documents shall be delivered to the Owner in the manner stated in the Notice of Award.

Article 13. Recyclable Products

13.1 Contractors must use recyclable products to the maximum extent economically feasible in the performance of the Contract.

OREGON STATE UNIVERSITY

BID FORM

PROJECT: DIXON CHILLER REPLACEMENT – RE-BID

BID DUE DATE/TIME: APRIL 10, 2019 AT 2:00 PM PACIFIC TIME

FROM: _____
Name of Contractor

TO: Oregon State University (“Owner”)
Construction Contract Administration
644 SW 13th Ave..
Corvallis, Oregon 97333

1. The Undersigned (check one of the following and insert information requested):

- a. An individual doing business under an assumed name registered under the laws of the State of _____; or
b. A partnership registered under the laws of the State of _____; or
c. A corporation organized under the laws of the State of _____; or
d. A limited liability corporation/company organized under the laws of the State of _____;

hereby proposes to furnish all material and labor and perform all work hereinafter indicated for the above project in strict accordance with the Contract Documents for the Basic Bid as follows:

_____ Dollars (\$_____)

and the Undersigned agrees to be bound by the following documents:

- Notice of Opportunity
• Supplemental Instructions to Bidders
• Performance Bond and Payment Bond
• Supplemental OSU General Conditions
• Prevailing Wage Rates
• Plans and Specifications
• ADDENDA numbered _____ through _____, inclusive (fill in blanks)
• Instructions to Bidders
• Sample Contract
• OSU General Conditions
• Payroll and Certified Statement Form
• Drawings and Details

2. The work shall be completed within the time stipulated and specified in Division 1, Section 01 11 00, of the Specifications.

3. The Undersigned certifies that: (1) This Bid has been arrived at independently and is being submitted without collusion with and without any agreement, understanding, or planned common course of action with any other vendor of materials, supplies, equipment or services described in the invitation to bid designed to limit independent bidding or competition; and (2) The contents of the Bid have not been

communicated by the Undersigned or its employees or agents to any person not an employee or agent of the Undersigned or its surety on any Bond furnished with the Bid and will not be communicated to such person prior to the official opening of the Bid.

4. The undersigned **HAS, HAS NOT** (*circle applicable status*) paid unemployment or income taxes in Oregon within the past 12 months and **HAS, HAS NOT** (*circle applicable status*) a business address in Oregon..

5. The Undersigned agrees, if awarded a contract, to comply with the provisions of ORS 279C.800 through 279C.870 pertaining to the payment of the prevailing rates of wage.

6. Contractor's CCB registration number is _____. As a condition to submitting a bid, a Contractor must be registered with the Oregon Construction Contractors Board in accordance with ORS 701.035 to 701.055, and disclose the registration number. Failure to register and disclose the number will render the bid unresponsive and it will be rejected, unless contrary to federal law.

7. The successful Bidder hereby certifies that all subcontractors who will perform construction work as described in ORS 701.005(2) were registered with the Construction Contractors Board in accordance with ORS 701.035 to 701.055 at the time the subcontractor(s) made a bid to work under the Contract.

8. The successful Bidder hereby certifies that, in compliance with the Worker's Compensation Law of the State of Oregon, its Worker's Compensation Insurance provider is _____, Policy No. _____, and that Contractor shall submit Certificates of Insurance as required.

9. Contractor's Project Manager for this project is: _____,
Office Phone: _____ Cell Phone: _____.

10. The Undersigned certifies that it has not discriminated against minority, women, or emerging small businesses in obtaining any subcontracts for this project.

11. The Undersigned agrees, if awarded the Contract, to execute and deliver to Owner, within twenty (20) calendar days after receiving the Contract Documents, an Agreement Form and a satisfactory Performance Bond and Payment Bond, each in an amount equal to one hundred (100) percent of the Contract sum, using forms provided by the Owner. The surety requested to issue the Performance Bond and Payment Bond will be: _____.
(name of surety company - not insurance agency)

The Undersigned hereby authorizes said surety company to disclose any information to the Owner concerning the Undersigned's ability to supply a Performance Bond and Payment Bond each in the amount of the Contract.

By signature below, Contractor agrees to be bound by this Bid.

NAME OF FIRM _____

ADDRESS _____

FEDERAL TAX ID _____

TELEPHONE NO _____

FAX NO _____

SIGNATURE 1) _____

Sole Individual - Signature

Sole Individual - Printed Name

or 2) _____

Partner

or 3) _____

Authorized Officer of Corporation - Signature

Authorized Officer of Corporation Printed Name

(SEAL)

Attested: Secretary of Corporation

*Payment information will be reported to the IRS under the name and taxpayer ID # provided above.
Information not matching IRS records could subject Contractor to 31 percent backup withholding.*

******* END OF BID *******

**OSU RETAINER CONTRACT SUPPLEMENT
OSU RETAINER CONTRACT FOR CONSTRUCTION
RELATED SERVICES
SUPPLEMENT NO.: OSU-xxx-C-16-xx
PROJECT NAME**

This OSU Retainer Contract Supplement dated XXXX (the "Supplement") is entered into between:

"Contractor":

and "Owner":

Oregon State University
Construction Contract Administration
644 SW 13th Ave
Corvallis, OR 97333

(collectively the "Parties") pursuant to the OSU Retainer Contract for Construction Related Services between the Parties (the "Retainer Contract"). Capitalized terms have the meaning defined in the Retainer General Conditions unless otherwise defined in the Retainer Contract or herein.

- 1. DESCRIPTION OF THE PROJECT.** The project to which this Supplement pertains is described as follows: (the "Project").
- 2. WORK TO BE PERFORMED.** Contractor shall perform the following work on the Project: (the "Work"). Contractor will perform the Work according to the terms and conditions of this Supplement and the Contract Documents, which are incorporated herein by this reference.
- 3. SCHEDULE.** Contractor shall perform the Work according to the following schedule: (the "Schedule").
- 4. COMPENSATION.** Owner shall compensate Contractor for Work in the firm, fixed-price amount of \$XXX.XX in accordance with the requirements of the OSU Retainer General Conditions.

The cost of the Work under this Supplement, even if this Supplement is later amended to include additional work, must not exceed the greater of \$1,000,000 or the maximum allowable under OSU standards and policies.

Contractor hereby agrees that the Work set forth in this Supplement may continue beyond the Term of the Retainer Contract and will be performed through final completion of Contractor's Work, including completion of all warranty work. The Parties expressly agree that they may execute a Supplement Amendment and extend the date which Contractor's Work may be completed, which may include a date beyond the Term of the Retainer Contract.

Termination or suspension does not extinguish or prejudice Owner's right to enforce the Supplement with respect to any breach by the Contractor that has not been cured.

5. TERM. This Supplement is effective on the date it has been signed by every Party hereto (the "Supplement Effective Date"). No Work shall be performed or payment made prior to the Supplement Effective Date. Contractor shall perform its obligations in accordance with the Contract Documents, unless this Supplement is earlier terminated or suspended.

6. PERFORMANCE AND PAYMENT BONDS. The performance and payment bond requirements for this Project are as follows (check one of the following):

As a condition precedent to the effectiveness of this Supplement and to Owner's obligation to make payment for the Work, Contractor shall provide the Owner with a performance bond and a separate payment bond in a sum equal to the Contract Price stated in Section 4 of this Supplement.

This Project has a Contract price of \$100,000 or less, and Owner has determined that performance and payment bonds will not be required for this Project.

7. PREVAILING WAGE RATES.

Prevailing Wage Rates requirements apply to this Project. Contractor and all subcontractors shall comply with the provisions of ORS 279C.800 through 279C.870, relative to Prevailing Wage Rates and the required public works bond, as outlined in Sections C.1, C.2 and G.2.3 of the Retainer General Conditions. The Bureau of Labor and Industries (BOLI) wage rates and requirements set forth in the following BOLI booklet (and any listed amendments to that booklet), which are incorporated herein by reference, apply to the Work authorized under this Supplement:

PREVAILING WAGE RATES for Public Works Contracts in Oregon, XXXX, as amended XXXX, which can be downloaded at the following web address:

[http://www.boli.state.or.us/BOLI/WHD/PWR/pwr_book.shtml]

The Work will take place in XXX County, Oregon.

8. INSURANCE REQUIREMENTS.

Contractor shall comply with and obtain the insurance coverage amounts stated in the Retainer General Conditions.

The Owner has determined that the Contractor shall obtain insurance in the amount described in the Retainer Supplemental General Conditions, attached hereto.

9. OTHER TERMS. Except as specifically modified by this Supplement, all terms of the Retainer Contract remain unchanged.

10. EXECUTION AND COUNTERPARTS. This Supplement may be executed in several counterparts, each of which shall be an original, all of which shall constitute but one and the same instrument.

Contractor hereby confirms and certifies that the representations, warranties, and certifications contained in the Retainer Contract remain true and correct as of the Effective Date of this Supplement.

IN WITNESS HEREOF, the Parties have duly executed this Supplement as of the dates indicated below.

, Contractor

Oregon State University, Owner

Print Name: _____

Print Name: Anita Nina Azarenko

Signature: _____

Signature: _____

Title: _____

Title: Associate Vice President for
University Facilities, Infrastructure and
Operations

Date: _____

Date: _____

OREGON STATE UNIVERSITY

PERFORMANCE BOND

Bond No. _____
Solicitation _____
Project Name _____

_____ (Surety #1) Bond Amount No. 1: \$ _____
_____ (Surety #2)* Bond Amount No. 2: * \$ _____
* *If using multiple sureties* Total Penal Sum of Bond: \$ _____

We, _____ as Principal, and the above identified Surety(ies), authorized to transact surety business in Oregon, as Surety, hereby jointly and severally bind ourselves, our respective heirs, executors, administrators, successors and assigns firmly by these presents to pay unto Oregon State University (OSU), the sum of (Total Penal Sum of Bond)

_____ (Provided, that we the Sureties bind ourselves in such sum “jointly and severally” as well as “severally” only for the purpose of allowing a joint action or actions against any or all of us, and for all other purposes each Surety binds itself, jointly and severally with the Principal, for the payment of such sum only as is set forth opposite the name of such Surety), and

WHEREAS, the Principal has entered into contract No. _____ with the OSU, the plans, specifications, terms and conditions of which are contained within the Contract resulting from the above-referenced Solicitation;

WHEREAS, the terms and conditions of the Contract, together with applicable plans, standard specifications, special provisions, schedule of performance, and schedule of Contract prices, are made a part of this Performance Bond by reference, whether or not attached to the contract (all hereafter called “Contract”); and

WHEREAS, the Principal has agreed to perform the Contract in accordance with the terms, conditions, requirements, plans and specifications, and all authorized modifications of the Contract which increase the amount of the work, the amount of the Contract, or constitute an authorized extension of the time for performance, notice of any such modifications hereby being waived by the Surety:

NOW, THEREFORE, THE CONDITION OF THIS BOND IS SUCH that if the Principal herein shall (1) faithfully and truly observe and comply with the terms, conditions and provisions of the Contract, in all respects, (2) shall well and truly and fully do and perform all matters and things undertaken by Contractor to be performed under the Contract, upon the terms set forth therein, and within the time prescribed therein, or as extended as provided in the Contract, with or without notice to the Sureties, (3) shall save, defend, indemnify and hold harmless OSU and its officers, board members, employees, agents and other representatives, against any direct or indirect damages or claim of every kind and description that shall be suffered or claimed to be suffered in connection with or arising out of the performance of the Contract by

the Principal or its subcontractors, and (4) shall in all respects perform said contract according to law, then this obligation is to be void; otherwise, it shall remain in full force and effect.

Nonpayment of the bond premium will not invalidate this bond, nor shall OSU be obligated for the payment of any premiums.

This bond is given and received under authority of ORS Chapters 279C and 352, the provisions of which hereby are incorporated into this bond and made a part hereof.

IN WITNESS WHEREOF, WE HAVE CAUSED THIS INSTRUMENT TO BE EXECUTED AND SEALED BY OUR DULY AUTHORIZED LEGAL REPRESENTATIVES.

Dated this _____ day of _____, 20__.

PRINCIPAL: _____

By _____

Signature

Official Capacity

Attest: _____

Corporation Secretary

SURETY: _____

[Add signatures for each surety if using multiple bonds]

BY ATTORNEY-IN-FACT:

[Power-of-Attorney must accompany each surety bond]

Name

Signature

Address

City State Zip

Phone Fax

OREGON STATE UNIVERSITY

PAYMENT BOND

Bond No. _____
Solicitation _____
Project Name _____

_____ (Surety #1)	Bond Amount No. 1:	\$ _____
_____ (Surety #2)*	Bond Amount No. 2:*	\$ _____
<i>* If using multiple sureties</i>	Total Penal Sum of Bond:	\$ _____

We, _____, as Principal, and the above identified Surety(ies), authorized to transact surety business in Oregon, as Surety, hereby jointly and severally bind ourselves, our respective heirs, executors, administrators, successors and assigns firmly by these presents to pay unto Oregon State University (OSU) the sum of (Total Penal Sum of Bond) _____ (Provided, that we the Sureties bind ourselves in such sum “jointly and severally” as well as “severally” only for the purpose of allowing a joint action or actions against any or all of us, and for all other purposes each Surety binds itself, jointly and severally with the Principal, for the payment of such sum only as is set forth opposite the name of such Surety), and

WHEREAS, the Principal has entered into contract No. _____ with OSU, the plans, specifications, terms and conditions of which are contained within the Contract resulting from the above-referenced Solicitation;

WHEREAS, the terms and conditions of the contract, together with applicable plans, standard specifications, special provisions, schedule of performance, and schedule of contract prices, are made a part of this Payment Bond by reference, whether or not attached to the contract (all hereafter called “Contract”); and

WHEREAS, the Principal has agreed to perform the Contract in accordance with the terms, conditions, requirements, plans and specifications, and schedule of contract prices which are set forth in the Contract and any attachments, and all authorized modifications of the Contract which increase the amount of the work, or the cost of the Contract, or constitute authorized extensions of time for performance of the Contract, notice of any such modifications hereby being waived by the Surety:

NOW, THEREFORE, THE CONDITION OF THIS BOND IS SUCH that if the Principal shall (1) faithfully and truly observe and comply with the terms, conditions and provisions of the Contract, in all respects, (2) shall well and truly and fully do and perform all matters and things by it undertaken to be performed under said Contract and any duly authorized modifications that are made, upon the terms set forth therein, and within the time prescribed therein, or as extended therein as provided in the Contract, with or without notice to the Sureties, (3) shall save, defend, indemnify and hold harmless OSU, and its officers, board members, employees, agents and other representatives, against any claim for direct or indirect damages of every kind and description that shall be suffered or claimed to be suffered in connection with or arising out of the performance of the Contract by the Contractor or its subcontractors, (4) shall promptly pay all persons supplying labor, materials or both to the Principal or its subcontractors for prosecution of the work provided in the Contract; (5) shall promptly pay all contributions due the State Industrial Accident Fund and the State Unemployment Compensation Fund from the Principal or its

subcontractors in connection with the performance of the Contract; (6) shall pay over to the Oregon Department of Revenue all sums required to be deducted and retained from the wages of employees of the Principal and its subcontractors pursuant to ORS 316.167;(7) shall permit no lien nor claim to be filed or prosecuted against the State or OSU on account of any labor or materials furnished; and (8) shall do all things required of the Principal by the laws of this State, then this obligation shall be void; otherwise, it shall remain in full force and effect.

Nonpayment of the bond premium will not invalidate this bond, nor shall OSU be obligated for the payment of any premiums.

This bond is given and received under authority of ORS Chapters 279C and 352, the provisions of which hereby are incorporated into this bond and made a part hereof.

IN WITNESS WHEREOF, WE HAVE CAUSED THIS INSTRUMENT TO BE EXECUTED AND SEALED BY OUR DULY AUTHORIZED LEGAL REPRESENTATIVES:

Dated this _____ day of _____, 20__.

PRINCIPAL: _____

By _____
Signature

Official Capacity

Attest: _____
Corporation Secretary

SURETY: _____

[Add signatures for each if using multiple bonds]

BY ATTORNEY-IN-FACT:

[Power-of-Attorney must accompany each bond]

Name

Signature

Address

City State Zip

Phone Fax

OREGON STATE UNIVERSITY GENERAL CONDITIONS FOR RETAINER CONTRACTS

November 1, 2018

INSTRUCTIONS: The attached **Oregon State University General Conditions for Retainer Contracts** ("Retainer General Conditions") apply to all designated retainer contracts. Changes to the Retainer General Conditions (including any additions, deletions or substitutions) should only be made by attaching Retainer Supplemental General Conditions. The text of these Retainer General Conditions should not otherwise be altered.

TABLE OF SECTIONS

SECTION A **GENERAL PROVISIONS**

- A.1 DEFINITION OF TERMS
- A.2 SCOPE OF WORK
- A.3 INTERPRETATION OF CONTRACT DOCUMENTS
- A.4 EXAMINATION OF PLANS, SPECIFICATIONS, AND SITE
- A.5 INDEPENDENT CONTRACTOR STATUS
- A.6 RETIREMENT SYSTEM STATUS AND TAXES
- A.7 GOVERNMENT EMPLOYMENT STATUS

SECTION B **ADMINISTRATION OF THE CONTRACT**

- B.1 OWNER'S ADMINISTRATION OF THE CONTRACT
- B.2 CONTRACTOR'S MEANS AND METHODS
- B.3 MATERIALS AND WORKMANSHIP
- B.4 PERMITS
- B.5 COMPLIANCE WITH GOVERNMENT REGULATIONS
- B.6 SUPERINTENDENCE
- B.7 INSPECTION
- B.8 SEVERABILITY
- B.9 ACCESS TO RECORDS
- B.10 WAIVER
- B.11 SUBCONTRACTS AND ASSIGNMENT
- B.12 SUCCESSORS IN INTEREST
- B.13 OWNER'S RIGHT TO DO WORK
- B.14 OTHER CONTRACTS
- B.15 GOVERNING LAW
- B.16 LITIGATION
- B.17 ALLOWANCES
- B.18 SUBMITTALS, SHOP DRAWINGS, PRODUCT DATA, AND SAMPLES
- B.19 SUBSTITUTIONS
- B.20 USE OF PLANS AND SPECIFICATIONS
- B.21 FUNDS AVAILABLE AND AUTHORIZED
- B.22 NO THIRD PARTY BENEFICIARIES

SECTION C **WAGES AND LABOR**

- C.1 MINIMUM WAGES RATES ON PUBLIC WORKS
- C.2 PAYROLL CERTIFICATION AND FEE REQUIREMENTS
- C.3 PROMPT PAYMENT AND CONTRACT CONDITIONS
- C.4 PAYMENT FOR MEDICAL CARE
- C.5 HOURS OF LABOR

SECTION D **CHANGES IN THE WORK**

- D.1 CHANGES IN THE WORK
- D.2 DELAYS
- D.3 CLAIMS REVIEW PROCESS

SECTION E
PAYMENTS

- E.1 SCHEDULE OF VALUES
- E.2 APPLICATIONS FOR PAYMENT
- E.3 PAYROLL CERTIFICATION REQUIREMENT
- E.4 DUAL PAYMENT SOURCES
- E.5 RETAINAGE
- E.6 FINAL PAYMENT

SECTION F
JOB SITE CONDITIONS

- F.1 USE OF PREMISES
- F.2 PROTECTION OF WORKERS, PROPERTY, AND THE PUBLIC
- F.3 CUTTING AND PATCHING
- F.4 CLEANING UP
- F.5 ENVIRONMENTAL CONTAMINATION
- F.6 ENVIRONMENTAL CLEAN-UP
- F.7 FORCE MAJEURE

SECTION G
INDEMNITY, BONDING AND INSURANCE

- G.1 RESPONSIBILITY FOR DAMAGES/INDEMNITY
- G.2 PERFORMANCE AND PAYMENT SECURITY, PUBLIC WORKS BOND
- G.3 INSURANCE

SECTION H
SCHEDULE OF WORK

- H.1 CONTRACT PERIOD
- H.2 SCHEDULE
- H.3 PARTIAL OCCUPANCY OR USE

SECTION I
CORRECTION OF WORK

- I.1 CORRECTIONS OF WORK BEFORE FINAL PAYMENT
- I.2 WARRANTY WORK

SECTION J
SUSPENSION AND/OR TERMINATION OF THE WORK

- J.1 OWNER'S RIGHT TO SUSPEND THE WORK
- J.2 CONTRACTOR'S RESPONSIBILITIES
- J.3 COMPENSATION FOR SUSPENSION
- J.4 OWNER'S RIGHT TO TERMINATE CONTRACT
- J.5 TERMINATION FOR CONVENIENCE
- J.6 ACTION UPON TERMINATION

SECTION K
CONTRACT CLOSE-OUT

- K.1 RECORD DOCUMENTS
- K.2 OPERATION AND MAINTENANCE MANUALS
- K.3 COMPLETION NOTICES
- K.4 TRAINING
- K.5 EXTRA MATERIALS
- K.6 ENVIRONMENTAL CLEAN-UP
- K.7 CERTIFICATE OF OCCUPANCY
- K.8 OTHER CONTRACTOR RESPONSIBILITIES
- K.9 SURVIVAL

**OREGON STATE UNIVERSITY
GENERAL CONDITIONS FOR RETAINER CONTRACTS
("Retainer General Conditions")**

**SECTION A
GENERAL PROVISIONS**

A.1 DEFINITION OF TERMS

In the Contract Documents, the following terms shall be as defined below:

AMENDMENT, means a writing which, when fully executed by the Parties to this Contract, constitutes a change to a Contract Document. Amendments to Supplements (hereinafter a "Supplement Amendment") shall be issued in accordance with the changes provisions of Section D and, if applicable, establish a Contract Price or Contract Time adjustment.

APPLICABLE LAWS, means federal, state and local laws, codes, rules, regulations and ordinances applicable to the Work and to the Contract.

ARCHITECT/ENGINEER, means the Person appointed by the Owner to make drawings and specifications and, to provide contract administration of the Work contemplated by the Contract to the extent provided herein or by supplemental instruction of Owner (under which Owner may delegate responsibilities to the Architect/Engineer), in accordance with ORS Chapter 671 (Architects) or ORS Chapter 672 (Engineers) and administrative rules adopted thereunder.

CHANGE ORDER, means a written order issued by the Owner to be later included as an Amendment. A Change Order shall not be effective until codified as an Amendment.

CLAIM, means a demand by Contractor pursuant to Section D.3 for review of the denial of Contractor's initial request for an adjustment of Contract terms, payment of money, extension of Contract Time or other relief, submitted in accordance with the requirements and within the time limits established for review of Claims in these Retainer General Conditions.

CONSTRUCTION CHANGE DIRECTIVE, means a written order by the Owner to the Contractor requiring a change in the Work within the general scope of the Contract Documents, issued under the changes provisions of Section D.

CONSTRUCTION SCHEDULE, means the schedule prepared by the Contractor in CPM format and approved by the Owner, and all adjustments thereto approved by the Owner, that describes sequence and timing of the Work.

CONTRACT, means the written agreement between the Owner and the Contractor comprised of the Contract Documents which describe the Work to be done and the obligations between the parties.

CONTRACT DOCUMENTS, means the Retainer Contract, Retainer General Conditions, Supplemental General Conditions if any, Supplements, the accepted Offer, Plans, Specifications, Change Orders, Amendments, Construction Change Directives, Solicitation Document and addenda thereto, Instructions to Offerors, and Supplemental Instructions to Offerors, the Construction Schedule prepared and approved in accordance with the Construction Documents, and all other required Submittals.

CONTRACT PERIOD, as set forth in the Contract Documents, means the total period of time beginning with the full execution of a Supplement and, if applicable, the issuance of a Notice to Proceed and concluding upon Final Completion.

CONTRACT PRICE, means the total of the awarded Offer amount, as increased or decreased by the price of approved alternates, as indicated in the Contract Documents.

CONTRACT TIME, means any incremental period of time allowed under the Contract to complete any portion of the Work as reflected in the project schedule.

CONTRACTOR, means the Person awarded the Contract for the Work contemplated.

CPM, means a critical path method format to be used for the Construction Schedule.

DAYS, are calendar days, including weekdays, weekends and holidays, unless otherwise specified.

DIRECT COSTS, means, unless otherwise provided in the Contract Documents, the cost of materials, including sales tax, cost of delivery; cost of labor, including social security, Medicare and unemployment insurance, and fringe benefits required by agreement or custom; worker's compensation insurance; project specific insurance (including, without limitation, Builder's Risk Insurance and Builder's Risk Installation Floater); bond premiums, rental cost of equipment, and machinery required for execution of the Work; and the additional costs of field personnel directly attributable to the Work.

FINAL COMPLETION, means the final completion of all requirements under the Contract, including Contract Closeout as described in Section K but excluding Warranty Work as described in Section I.2, and the final payment and release of all retainage, if any, released.

FINAL PAYMENT, means the last payment to the Contractor, including retainage, in connection with the Work.

FORCE MAJEURE, means an act, event or occurrence caused by fire, riot, war, acts of God, nature, sovereign, or public enemy, strikes, freight embargoes or any other act, event or occurrence that is beyond the control of the party to this Contract who is asserting Force Majeure.

MWESB REPORT, means an accurate report by the Contractor to the Owner identifying all Minority, Women and Emerging Small Business (MWESB) enterprises, as those terms are defined in ORS 200.005, receiving contracts throughout the course of the Work. An initial MWESB report is required (see Section E.2.9) and MWESB Reports are required annually (see Section E.2.9) and as a condition of final payment (see Section K.1). The initial report shall include the total number of contracts and subcontracts awarded to MWESB enterprises and the dollar value of their respective contracts and subcontracts. The annual reports shall include the total number of contracts and subcontracts awarded to MWESB enterprises, the dollar value of each, and the expenditure toward each contract and subcontract during the previous twelve (12) months. The final report shall include the total number of contracts and subcontracts awarded to MWESB enterprises and the dollar value of their respective contracts and subcontracts including all Supplements and Amendments incorporated during the course of the project. The reports shall only include enterprises certified with the State of Oregon as MWESB enterprises and shall include individual identification of each enterprise as a Minority business enterprise, a Women business enterprise, and/or an Emerging Small Business Enterprise, as applicable.

NOTICE TO PROCEED, means the official written notice from the Owner stating that the Contractor is to proceed with the Work defined in the Contract Documents. Notwithstanding the Notice to Proceed, Contractor shall not be authorized to proceed with the Work until all initial Contract requirements, including the Contract, performance bond and payment bond, and certificates of insurance, have been fully executed and submitted to Owner in a suitable form.

OFFER, means a bid in connection with Instructions to Bidders or a proposal in connection with a Request for Proposals.

OFFEROR, means a bidder in connection with Instructions to Bidders or a proposer in connection with a Request for Proposals.

OVERHEAD, means those items which may be included in the Contractor's markup (general and administrative expense and profit) and that shall not be charged as Direct Cost of the Work, including without limitation such Overhead expenses as wages or salary of personnel above the level of foreman (i.e., superintendents and project managers), expenses of Contractor's offices and supplies at the job site (e.g. job trailer) and at Contractor's principal place of business and including expenses of personnel staffing the job site office and Contractor's principal place of business, and Commercial General Liability Insurance and Automobile Liability Insurance.

OWNER, means Oregon State University (OSU). Owner may elect, by written notice to Contractor, to delegate certain duties to more than one party, including without limitation, to an Architect/Engineer. However, nothing in these Retainer General Conditions is intended to abrogate the separate design professional responsibilities of Architects under ORS Chapter 671 or of Engineers under ORS Chapter 672.

PERSON, means a natural person or entity doing business as a sole proprietorship, a partnership, a joint venture, a corporation, a limited liability company or partnership, or any other entity possessing the legal capacity to contract.

PLANS, means the drawings which show the location, type, dimensions, and details of the Work to be done under the Contract.

PROJECT, means the total design, development and construction of which the Work performed under the Construction Documents may be the whole or a part.

PUNCH LIST, means the list of Work yet to be completed or deficiencies which need to be corrected in order to achieve Final Completion of the Contract.

RECORD DOCUMENT, means the as-built Plans, Specifications, testing and inspection records, product data, samples, manufacturer and distributor/supplier warranties evidencing transfer of ownership to Owner, operational and maintenance manuals, shop drawings, Construction Change Directives, MWESB Reports, correspondence, certificate(s) of occupancy, and other documents listed in Subsection B.9.1 of these Retainer General Conditions, recording all Services performed.

RETAINER SUPPLEMENTAL GENERAL CONDITIONS, means those conditions that remove from, add to, or modify these Retainer General Conditions. Retainer Supplemental General Conditions may be included in the Solicitation Document or may be a separate attachment to the Contract.

SOLICITATION DOCUMENT, means Instructions to Bidders or Offerors or a Request for Proposal or a Request for Quotes.

SPECIFICATION, means any description of the physical or functional characteristics of the Work, or of the nature of a supply, service or construction item. Specifications may include a description of any requirement for inspecting, testing or preparing a supply, service or construction item for delivery and the quantities or qualities of materials to be furnished under the Contract. Specifications generally

will state the results or products to be obtained and may, on occasion, describe the method and manner of doing the Work to be performed. Specifications may be incorporated by reference and/or may be attached to the Contract.

SUBCONTRACT, means a contract between the Contractor and a subcontractor for the performance of a portion of the Work.

SUBCONTRACTOR, means a Person having a direct contract with the Contractor, or another Subcontractor, to perform one or more items of the Work.

SUBSTANTIAL COMPLETION, means the date when the Owner accepts in writing the construction, alteration or repair of the improvement to real property constituting the Work or any designated portion thereof as having reached that state of completion when it may be used or occupied for its intended purpose. Substantial Completion of facilities with operating systems occurs only after thirty (30) continuous Days of successful, trouble-free operation of the operating systems as provided in Section K.3.2.

SUBSTITUTIONS, means items that in function, performance, reliability, quality, and general configuration are the same or better than the product(s) specified. Approval of any substitute item shall be solely determined by the Owner. The decision of the Owner is final.

SUPPLEMENT, means a writing which, when fully executed by the Parties thereto, constitutes written agreement between the Owner and the Contractor comprised of the Contract Documents which describe the Work to be done and the obligations between the parties.

WORK, means the furnishing of all materials, equipment, labor, transportation, services and incidentals necessary to successfully complete any individual item or the entire Contract and the carrying out of duties and obligations imposed by the Contract Documents.

A.2 SCOPE OF WORK

The Work contemplated under this Contract includes all labor, materials, transportation, equipment and services for, and incidental to, the completion of all construction work in connection with the project described in the Contract Documents. The Contractor shall perform all Work necessary so that the project can be legally occupied and fully used for the intended use as set forth in the Contract Documents. Execution of the Contract by the Contractor is an express representation (1) that the Contractor understands the intent stated herein with respect to the Preconstruction Phase Services, and (2) the Contractor's execution of an Amendment, including the GMP Amendment, shall be an express and unqualified representation that the Contractor understands the intent stated herein and therein.

A.3 INTERPRETATION OF CONTRACT DOCUMENTS

A.3.1 Unless otherwise specifically defined in the Contract Documents, words which have well-known technical meanings or construction industry meanings are used in the Contract Documents in accordance with such recognized meanings. Contract Documents are intended to be complementary. Whatever is called for in one is interpreted to be called for in all. However, in the event of conflicts or discrepancies among the Contract Documents, interpretations will be based on the following descending order of precedence:

- (a) Contract Supplements, Amendments and Construction Change Directives, with those of later date having precedence over those of an earlier date;
- (b) The Retainer Supplemental General Conditions;
- (c) Retainer General Conditions;
- (d) The Retainer Contract Supplements;

- (e) Construction Change Directive;
- (f) Division One (General Requirements) of the Specifications;
- (g) Detailed Schedules of finishes, equipment and other items included in the Specifications;
- (h) Plans and Specifications (other than Division One and the Detailed Schedules to the Specifications);
- (i) Large-scale drawings on Plans;
- (j) Small-scale drawings on Plans;
- (k) Dimension numbers written on Plans which shall prevail and take precedence over dimensions scaled from Plans;
- (l) The Solicitation Document, and any addenda thereto;
- (m) The Retainer Contract.

A.3.2 In the case of an inconsistency between Plans and Specifications or within either document not clarified by addendum, the better quality or greater quantity of Work shall be provided in accordance with the Owner's interpretation in writing.

A.3.3 If the Contractor finds discrepancies in, or omissions from the Contract Documents, or if the Contractor is in doubt as to their meaning, the Contractor shall at once notify the Owner. Matters concerning and interpretation of requirements of the Contract Documents will be decided by the Owner, who may delegate that duty in some instances to the Architect/Engineer. Responses to Contractor's requests for interpretation of Contract Documents will be made in writing by Owner (or the Architect/Engineer) within any time limits agreed upon or otherwise with reasonable promptness. Interpretations and decisions of the Owner (or Architect/Engineer) will be consistent with the intent of and reasonably inferable from the Contract Documents. Contractor shall not proceed without direction in writing from the Owner (or Architect/Engineer).

A.3.4 References to standard specifications, manuals, codes of any technical society, organization or association, to the laws or regulations of any governmental authority, whether such reference be specific or by implication, shall mean the latest standard specification, manual, code, laws or regulations in effect in the jurisdiction where the project is occurring on the first published date of the Solicitation Document, except as may be otherwise specifically stated.

A.4 EXAMINATION OF PLANS, SPECIFICATIONS, AND SITE

A.4.1 It is understood that the Contractor, before submitting an Offer, has made a careful examination of the Contract Documents; has become fully informed as to the quality and quantity of materials and the character of the Work required; and has made a careful examination of the location and conditions of the Work and the sources of supply for materials. The Owner will in no case be responsible for any loss or for any unanticipated costs that may be suffered by the Contractor as a result of the Contractor's failure to acquire full information in advance in regard to all conditions pertaining to the Work. No oral agreement or conversation with any officer, agent, or personnel of the Owner, or with the Architect/Engineer either before or after the execution of this Contract, shall affect or modify any of the terms or obligations herein contained.

A.4.2 Should the Plans or Specifications fail to particularly describe the materials, kind of goods, or details of construction of any aspect of the Work, Contractor shall have the duty to make

inquiry of the Owner and Architect/Engineer as to what is required prior to performance of the Work. Absent Specifications to the contrary, the materials or processes that would normally be used to produce first quality finished Work shall be considered a part of the Contract requirements.

A.4.3 Any design errors or omissions noted by the Contractor shall be reported promptly to the Owner, and confirmed in writing including without limitation, any nonconformity with Applicable Laws.

A.4.4 If the Contractor believes that adjustments to cost or Contract Time is involved because of clarifications or instructions issued by the Owner (or Architect/Engineer) in response to the Contractor's notices or requests for information, the Contractor must submit a written request to the Owner, setting forth the nature and specific extent of the request, including all time and cost impacts against the Contract as soon as possible, but no later than thirty (30) Days after receipt by Contractor of the clarifications or instructions issued. If the Owner denies Contractor's request for additional compensation, additional Contract Time, or other relief that Contractor believes results from the clarifications or instructions, the Contractor may proceed to file a Claim under Section D.3, Claims Review Process. If the Contractor fails to perform the obligations of Sections A.4.1 to A.4.3, the Contractor shall pay such costs and damages to the Owner as would have been avoided if the Contractor had performed such obligations.

A.5 INDEPENDENT CONTRACTOR STATUS

The service or services to be performed under this Contract are those of an independent contractor as defined in ORS 670.600. Contractor represents and warrants that it is not an officer, employee or agent of the Owner as those terms are used in ORS 30.265.

A.6 RETIREMENT SYSTEM STATUS AND TAXES

Contractor represents and warrants that it is not a contributing member of the Public Employees' Retirement System and will be responsible for any federal or state taxes applicable to payment received under this Contract. Contractor will not be eligible for any benefits from these Contract payments of federal Social Security, employment insurance, workers' compensation or the Public Employees' Retirement System, except as a self-employed individual. Unless the Contractor is subject to backup withholding, Owner will not withhold from such payments any amount(s) to cover Contractor's federal or state tax obligations.

A.7 GOVERNMENT EMPLOYMENT STATUS

A.7.1 If this payment is to be charged against federal funds, Contractor represents and warrants that it is not currently employed by the Federal Government. This does not preclude the Contractor from holding another contract with the Federal Government.

A.7.2 Contractor represents and warrants that Contractor is not an employee of the State of Oregon for purposes of performing Work under this Contract

**SECTION B
ADMINISTRATION OF THE CONTRACT**

B.1 OWNER'S ADMINISTRATION OF THE CONTRACT

B.1.1 The Owner shall administer the Contract as described in the Contract Documents (1) during construction (2) until Final Payment is due and (3) during the one-year period for correction of Work. The Owner will act as provided in the Contract Documents, unless modified in writing in accordance with other provisions of the Contract. In performing these tasks, the Owner

may rely on the Architect/Engineer or other consultants to perform some or all of these tasks.

- B.1.2 The Owner will visit the site at intervals appropriate to the stage of the Contractor's operations (1) to become generally familiar with and to keep the Owner informed about the progress and quality of the portion of the Work completed, (2) to endeavor to guard the Owner against defects and deficiencies in the Work, and (3) to determine in general if Work is being performed in a manner indicating that the Work, when fully completed, will be in accordance with the Contract Documents. The Owner will not make exhaustive or continuous on-site inspections to check the quality or quantity of the Work. The Owner will neither have control over or charge of, nor be responsible for the construction means, methods, techniques, sequences or procedures, or for the safety precautions and programs in connection with the Work. Inspection of the progress, quantity, or quality of the Work done by the Owner, any Owner representative, and public agency, the Architect/Engineer, or any inspector, shall not relieve the Contractor of any responsibility for the compliance of all Work with the Contract Documents.
- B.1.3 Except as otherwise provided in the Contract Documents or when direct communications have been specifically authorized, the Owner and Contractor shall communicate with each other about matters arising out of or relating to the Contract. Communications by and with the Architect/Engineer's consultants shall be through the Architect/Engineer. Communications by and with Subcontractors and material suppliers shall be through the Contractor. Communications by and with separate contractors shall be through the Owner.
- B.1.4 Based upon the Architect/Engineer's evaluations of the Contractor's Application for Payment, or unless otherwise stipulated by the Owner, the Architect/Engineer will review and certify the amounts due the Contractor and will issue Certificates for Payment in such amounts.

B.2 CONTRACTOR'S MEANS AND METHODS; MITIGATION OF IMPACTS

- B.2.1 The Contractor shall supervise and direct the Work, using the Contractor's best skill and attention. The Contractor shall be solely responsible for and have control over construction means, methods, techniques, sequences and procedures and for coordinating all portions of the Work under the Contract, unless the Contract Documents give other specific instructions concerning these matters. If the Contract Documents give specific instructions concerning construction means, methods, techniques, sequences or procedures, the Contractor shall evaluate the jobsite safety thereof and, except as stated below, shall be fully and solely responsible for the jobsite safety of such means, methods, techniques, sequences or procedures.
- B.2.2 The Contractor is responsible to protect and maintain the Work during the course of construction and to mitigate any adverse impacts to the project, including those caused by authorized changes, which may affect cost, schedule, or quality.
- B.2.3 The Contractor is responsible for the actions of all its personnel, laborers, suppliers, and Subcontractors on the project. The Contractor shall enforce strict discipline and good order among Contractor's employees and other persons carrying out the Work. The Contractor shall not permit employment of persons who are unfit or unskilled for the tasks assigned to them.

B.3 MATERIALS AND WORKMANSHIP

- B.3.1 The intent of the Contract Documents is to provide for the construction and completion in every detail of the Work described. All Work shall be performed in a professional manner and unless the means or methods of performing a task

are specified elsewhere in the Contract Documents, Contractor shall employ methods that are generally accepted and used by the industry, in accordance with industry standards.

- B.3.2 The Contractor is responsible to perform the Work as required by the Contract Documents. Defective Work shall be corrected at the Contractor's expense.
- B.3.3 Work done and materials furnished shall be subject to inspection and/or observation and testing by the Owner to determine if they conform to the Contract Documents. Inspection of the Work by the Owner does not relieve the Contractor of responsibility for the Work in accordance with the Contract Documents.
- B.3.4 Contractor shall furnish adequate facilities, as required, for the Owner to have safe access to the Work including without limitation walkways, railings, ladders, tunnels, and platforms. Producers, suppliers, and fabricators shall also provide proper facilities and access to their facilities.
- B.3.5 The Contractor shall furnish Samples of materials for testing by the Owner and include the cost of the Samples in the Contract Price.

B.4 PERMITS

Contractor shall obtain and pay for all necessary permits and licenses, except for those specifically excluded in the Supplemental General Conditions, for the construction of the Work, for temporary obstructions, enclosures, opening of streets for pipes, walls, utilities, environmental Work, etc., as required for the Project. Owner shall obtain and pay for the general building permit and pay for any specialty permits required for the Work. Contractor shall be responsible for all violations of the law, in connection with the construction or caused by obstructing streets, sidewalks or otherwise. Contractor shall give all requisite notices to public authorities. The Contractor shall pay all royalties and license fees. The Contractor shall defend all suits or claims for infringement of any patent or other proprietary rights and save harmless and blameless from loss, on account thereof, Oregon State University, and its departments, divisions, members and employees.

B.5 COMPLIANCE WITH GOVERNMENT REGULATIONS

- B.5.1 Contractor shall comply with Applicable Laws pertaining to the Work and the Contract. Failure to comply with such requirements shall constitute a breach of Contract and shall be grounds for Contract termination. Without limiting the generality of the foregoing, Contractor expressly agrees to comply with the following, as applicable:
- (i) Title VI and VII of Civil Rights Act of 1964, as amended;
 - (ii) Section 503 and 504 of the Rehabilitation Act of 1973, as amended;
 - (iii) the Health Insurance Portability and Accountability Act of 1996;
 - (iv) the Americans with Disabilities Act of 1990, as amended;
 - (v) ORS Chapters 659 and 659A; as amended;
 - (vi) all regulations and administrative rules established pursuant to the foregoing laws; and
 - (vii) all other applicable requirements of federal and state civil rights and rehabilitation statutes, rules and regulations.
- B.5.2 Contractor shall comply with all applicable requirements of federal and state civil rights and rehabilitation statutes, rules and regulations, and
- (a) Contractor shall not discriminate against Disadvantaged, Minority, Women or Emerging Small Business enterprises, as those terms are defined in ORS 200.005, or a business enterprise that is owned or controlled by or that employs a disabled veteran, as that term is defined in ORS 408.225, in the awarding of subcontracts.

(b) Contractor shall maintain, in current and valid form, all licenses and certificates required by Applicable Laws or this Contract when performing the Work.

- B.5.3 Unless contrary to federal law, Contractor shall certify that it shall not accept a bid from Subcontractors to perform Work as described in ORS 701.005 under this Contract unless such Subcontractors are registered with the Construction Contractors Board in accordance with ORS 701.021 to 701.068 at the time they submit their bids to the Contractor.
- B.5.4 Unless contrary to federal law, Contractor shall certify that each landscape contractor, as defined in ORS 671.520(2), performing Work under this Contract holds a valid landscape contractor's license issued pursuant to ORS 671.560.
- B.5.5 The following notice is applicable to Contractors who perform excavation Work. ATTENTION: Oregon law requires you to follow rules adopted by the Oregon Utility Notification Center. Those rules are set forth in OAR 952-001-0010 through OAR 952-001-0100. You may obtain copies of the rules by calling the center at (503)232-1987.
- B.5.6 Failure to comply with any or all of the requirements of B.5.1 through B.5.5 shall be a breach of Contract and constitute grounds for Contract termination. Damages or costs resulting from such noncompliance shall be the responsibility of Contractor.

B.6 SUPERINTENDENCE

Contractor shall keep on the site, during the progress of the Work, a competent superintendent and any necessary assistants who shall be satisfactory to the Owner and who shall represent the Contractor on the site. Directions given to the superintendent by the Owner shall be confirmed in writing to the Contractor.

B.7 INSPECTION

- B.7.1 Owner shall have access to the Work at all times.
- B.7.2 Inspection of the Work will be made by the Owner at its discretion. The Owner will have authority to reject Work that does not conform to the Contract Documents. Any Work found to be not in conformance with the Contract Documents, in the discretion of the Owner, shall be removed and replaced at the Contractor's expense.
- B.7.3 Contractor shall make or obtain at the appropriate time all tests, inspections and approvals of portions of the Work required by the Contract Documents or by Applicable Laws or orders of public authorities having jurisdiction. Unless otherwise provided, the Contractor shall make arrangements for such tests, inspections and approvals with an independent testing laboratory or entity acceptable to the Owner, or with the appropriate public authority, and shall bear all related costs of tests, inspections and approvals. Tests or inspections conducted pursuant to the Contract Documents shall be made promptly to avoid unreasonable delay in the Work. The Contractor shall give the Owner timely notice of when and where tests and inspections are to be made so that the Owner may be present for such procedures. Required certificates of testing, inspection or approval shall, unless otherwise required by the Contract Documents, be secured by the Contractor and promptly delivered to the Owner.
- B.7.4 As required by the Contract Documents, Work done or material used without required inspection or testing and/or without providing timely notice to the Owner may be ordered removed at the Contractor's expense.

- B.7.5 If directed to do so any time before the Work is accepted, the Contractor shall uncover portions of the completed Work for inspection. After inspection, the Contractor shall restore such portions of Work to the standard required by the Contract. If the Work uncovered is unacceptable or was done without required testing or inspection or sufficient notice to the Owner, the uncovering and restoration shall be done at the Contractor's expense. If the Work uncovered is acceptable and was done with sufficient notice to the Owner, the uncovering and restoration will be paid for pursuant to a Supplement Amendment.
- B.7.6 If any testing or inspection reveals failure of the portions of the Work to comply with requirements established by the Contract Documents, all costs made necessary by such failure, including those of repeated procedures and compensation for the Owner's and Architect/Engineer's services and expenses, shall be at the Contractor's expense.
- B.7.7 When the United States government participates in the cost of the Work, or the Owner has an agreement with other public or private organizations, or if any portion of the Work is being performed for a third party or in close proximity to third party facilities, representatives of these organizations shall have the right to inspect the Work affecting their interests or property. Their right to inspect shall not make them a party to the Contract and shall not interfere with the rights of the parties of the Contract. Instructions or orders of such parties shall be transmitted to the Contractor, through the Owner.

B.8 SEVERABILITY

If any provision of this Contract is declared by a court to be illegal or in conflict with any law, the validity of the remaining terms and provisions shall not be affected and the rights and obligations of the parties shall be construed and enforced as if the Contract did not contain the particular provision held to be invalid.

B.9 ACCESS TO RECORDS

- B.9.1 Contractor shall keep, at all times on the Work site, one record copy of the complete Contract Documents, including the Plans, Specifications, Construction Change Directives and addenda, in good order and marked currently to record field changes and selections made during construction, and one record copy of Shop Drawings, Product Data, Samples and similar submittals, and shall at all times give the Owner access thereto.
- B.9.2 Contractor shall retain and the Owner and its duly authorized representatives shall have access, for a period not less than ten (10) years, to all Record Documents, financial and accounting records, and other books, documents, papers and records of Contractor which are pertinent to the Contract, including records pertaining to Overhead and indirect costs, for the purpose of making audit, examination, excerpts and transcripts. If for any reason, any part of the Work or this Contract shall be subject to litigation, Contractor shall retain all such records until all litigation is resolved and Contractor shall continue to provide Owner and/or its agents with full access to such records until such time as all litigation is complete and all periods for appeal have expired and full and final satisfaction of any judgment, order or decree is recorded and Owner receives a record copy of documentation from Contractor.

B.10 WAIVER

Failure of the Owner to enforce any provision of this Contract shall not constitute a waiver or relinquishment by the Owner of the right to such performance in the future nor of the right to enforce any other provision of this Contract.

B.11 SUBCONTRACTS AND ASSIGNMENT

- B.11.1 Contractor shall require each Subcontractor, to the extent of the Work to be performed by the Subcontractor, to be bound by the terms and conditions of these Retainer General Conditions, and to assume toward the Contractor all of the obligations and responsibilities which the Contractor assumes toward the Owner thereunder, unless (1) the same are clearly inapplicable to the subcontract at issue because of legal requirements or industry practices, or (2) specific exceptions are requested by Contractor and approved in writing by Owner. Where appropriate, Contractor shall require each Subcontractor to enter into similar agreements with sub-subcontractors at any level.
- B.11.2 At Owner's request, Contractor shall submit to Owner prior to their execution either Contractor's form of subcontract, or the subcontract to be executed with any particular Subcontractor. If Owner disapproves such form, Contractor shall not execute the form until the matters disapproved are resolved to Owner's satisfaction. Owner's review, comment upon or approval of any such form shall not relieve Contractor of its obligations under this Agreement or be deemed a waiver of such obligations of Contractor.
- B.11.3 Contractor shall not assign, sell, or transfer its rights, or delegate its responsibilities under this Contract, in whole or in part, without the prior written approval of the Owner. No such written approval shall relieve Contractor of any obligations of this Contract, and any transferee shall be considered the agent of the Contractor and bound to perform in accordance with the Contract Documents. Contractor shall remain liable as between the original parties to the Contract as if no assignment had occurred.

B.12 SUCCESSORS IN INTEREST

The provisions of this Contract shall be binding upon and shall accrue to the benefit of the parties to the Contract and their respective permitted successors and assigns.

B.13 OWNER'S RIGHT TO DO WORK

Owner reserves the right to perform other or additional work at or near the project site with other forces than those of the Contractor. If such work takes place within or next to the project site, Contractor shall coordinate work with the other contractors or forces, cooperate with all other contractors or forces, carry out the Work in a way that will minimize interference and delay for all forces involved, place and dispose of materials being used so as not to interfere with the operations of another, and join the Work with the work of the others in an acceptable manner and perform it in proper sequence to that of the others. The Owner will resolve any disagreements that may arise between or among Contractor and the other contractors over the method or order of doing all work (including the Work). In case of unavoidable interference, the Owner will establish work priority (including the Work) which generally will be in the sequence that the contracts were awarded.

B.14 OTHER CONTRACTS

In all cases and at any time, the Owner has the right to execute other contracts related to or unrelated to the Work of this Contract. The Contractor of this Contract shall fully cooperate with any and all other contractors without additional cost to the Owner in the manner described in section B.13.

B.15 GOVERNING LAW

This Contract shall be governed by and construed in accordance with the laws of the State of Oregon without regard to principles of conflict of laws.

B.16 LITIGATION

Any Claim between Owner and Contractor that arises from or relates to this Contract and that is not resolved through the Claims Review Process in Section D.3 shall be brought and conducted solely and exclusively within the Circuit Court of Benton County for the State of Oregon; provided, however, if a Claim must be brought in a federal forum, then it shall be brought and conducted solely and exclusively within the United States District Court for the District of Oregon. In no event shall this section be construed as a waiver by the State of Oregon on any form of defense or immunity, whether sovereign immunity, governmental immunity, immunity based on the Eleventh Amendment to the Constitution of the United States or otherwise, from any claim or from the jurisdiction of any court. CONTRACTOR, BY EXECUTION OF THIS CONTRACT, HEREBY CONSENTS TO THE IN PERSONAM JURISDICTION OF THE COURTS REFERENCED IN THIS SECTION B.16.

B.17 ALLOWANCES

- B.17.1 The Contractor shall include in the Contract Price all allowances stated in the Contract Documents. Items covered by allowances shall be supplied for such amounts and by such persons or entities as the Owner may direct.
- B.17.2 Unless otherwise provided in the Contract Documents:
- (a) When finally reconciled, allowances shall cover the cost to the Contractor of materials and equipment delivered at the site and all required taxes, less applicable trade discounts;
 - (b) Contractor's costs for unloading and handling at the site, labor, installation costs, Overhead, profit and other expenses contemplated for stated allowance amounts shall be included in the Contract Price but not in the allowances;
 - (c) Whenever costs are more than or less than allowances, the Contract Price shall be adjusted accordingly by Amendment. The amount of the Amendment shall reflect (i) the difference between actual costs and the allowances under Section B.17.2(a) and (2) changes in Contractor's costs under Section B.17.2(b).
 - (d) Unless Owner requests otherwise, Contractor shall provide to Owner a proposed fixed price for any allowance work prior to its performance.

B.18 SUBMITTALS, SHOP DRAWINGS, PRODUCT DATA AND SAMPLES

- B.18.1 The Contractor shall prepare and keep current, for the Architect's/Engineer's approval (or for the approval of Owner if approval authority has not been delegated to the Architect/Engineer), a schedule and list of Submittals which is coordinated with the Contractor's construction schedule and allows the Architect/Engineer reasonable time to review Submittals. Owner reserves the right to finally approve the schedule and list of Submittals. Submittals include, without limitation, Shop Drawings, product data, and samples which are described below:
- (a) Shop Drawings are drawings, diagrams, schedules and other data specially prepared for the Work by the Contractor or a Subcontractor (including any sub-subcontractor), manufacturer, supplier or distributor to illustrate some portion of the Work.
 - (b) Product Data are illustrations, standard schedules, performance charts, instructions, brochures, diagrams and other information furnished by the Contractor to illustrate materials or equipment for some portion of the Work.

(c) Samples are physical examples which illustrate materials, equipment or workmanship and establish standards by which the Work will be judged.

Architect/Engineer, or in the event no Architect/Engineer is employed by Owner on the project, all obligations and duties assigned to the Architect/Engineer hereunder shall be performed by the Owner.

B.18.2 Shop Drawings, Product Data, Samples and similar Submittals are not Contract Documents. The purpose of their Submittal is to demonstrate for those portions of the Work for which Submittals are required by the Contract Documents the way by which the Contractor proposes to conform to the information given and the design concept expressed in the Contract Documents. Review of Submittals by the Architect/Engineer is not conducted for the purpose of determining the accuracy and completeness of other details such as dimensions and quantities, or for substantiating instructions for installation or performance of equipment or systems, or for approval of safety precautions or, unless otherwise specifically stated by the Architect/Engineer, of any construction means, methods, techniques, sequences or procedures, all of which remain the responsibility of the Contractor as required by the Contract Documents. The Architect/Engineer's review of the Contractor's Submittals shall not relieve the Contractor of its obligations under the Contract Documents. The Architect/Engineer's approval of a specific item shall not indicate approval of an assembly of which the item is a component. Informational Submittals upon which the Architect/Engineer is not expected to take responsive action may be so identified in the Contract Documents. Submittals which are not required by the Contract Documents may be returned by the Architect/Engineer without action.

B.18.3 The Contractor shall review for compliance with the Contract Documents, approve and submit to the Architect/Engineer Shop Drawings, Product Data, Samples and similar Submittals required by the Contract Documents with reasonable promptness and in such sequence as to cause no delay in the Work or in the activities of the Owner or of separate contractors. Submittals which are not marked as reviewed for compliance with the Contract Documents and approved by the Contractor may be returned by the Architect/Engineer without action.

B.18.4 Approving and submitting shop drawings, product data, samples and similar Submittals, the Contractor represents that the Contractor has determined and verified materials, field measurements and field construction criteria related thereto, or will do so, and has checked and coordinated the information contained within such Submittals with the requirements of the Work and of the Contract Documents.

B.18.5 The Contractor shall perform no portion of the Work for which the Contract Documents require submittal and review of Shop Drawings, Product Data, Samples or similar Submittals until the respective Submittal has been approved by the Architect/Engineer.

B.18.6 The Work shall be in accordance with approved Submittals except that the Contractor shall not be relieved of responsibility for deviations from requirements of the Contract Documents by the Architect/Engineer's review or approval of Shop Drawings, Product Data, Samples or similar Submittals unless the Contractor has specifically informed the Architect/Engineer in writing of such deviation at the time of submittal and (i) the Architect/Engineer has given written approval to the specific deviation as a minor change in the Work, or (ii) a Supplement Amendment or Construction Change Directive has been executed by Owner authorizing the deviation. The Contractor shall not be relieved of responsibility for errors or omissions in Shop Drawings, Product Data, Samples or similar Submittals by the Architect/Engineer's review or approval thereof.

B.18.7 In the event that Owner elects not to have the obligations and duties described under this Section B.18 performed by the

B.19 SUBSTITUTIONS

The Contractor may make Substitutions only with the written consent of the Owner, after evaluation by the Owner and only in accordance with a Supplement Amendment or Construction Change Directive. Substitutions shall be subject to the requirements of the bid documents. By making requests for Substitutions, the Contractor: represents that the Contractor has personally investigated the proposed substitute product; represents that the Contractor will provide the same warranty for the Substitution that the Contractor would for the product originally specified unless approved otherwise; certifies that the cost data presented is complete and includes all related costs under this Contract including redesign costs, and waives all claims for additional costs related to the Substitution which subsequently become apparent; and will coordinate the installation of the accepted Substitution, making such changes as may be required for the Work to be completed in all respects.

B.20 USE OF PLANS AND SPECIFICATIONS

Plans, Specifications and related Contract Documents furnished to Contractor by Owner or Owner's Architect/Engineer shall be used solely for the performance of the Work under this Contract. Contractor and its Subcontractors and suppliers are authorized to use and reproduce applicable portions of such documents appropriate to the execution of the Work, but shall not claim any ownership or other interest in them beyond the scope of this Contract, and no such interest shall attach. Unless otherwise indicated, all common law, statutory and other reserved rights, in addition to copyrights, are retained by Owner.

B.21 FUNDS AVAILABLE AND AUTHORIZED

If Owner fails to receive funding, appropriations, allocations or other expenditure authority as contemplated by Owner's budget and Owner determines, in its assessment and ranking of the policy objectives explicit or implicit in Owner's budget, Owner may determine it is necessary to and may terminate the Retainer Contract, Supplements.

B.22 NO THIRD PARTY BENEFICIARIES

Owner and Contractor are the only parties to this Contract and are the only parties entitled to enforce its terms. Nothing in this Contract gives, is intended to give, or shall be construed to give or provide any benefit or right, whether directly, indirectly, or otherwise, to third persons unless such third persons are individually identified by name herein and expressly described as intended beneficiaries of the terms of this Contract.

SECTION C WAGES AND LABOR

C.1 MINIMUM WAGE RATES ON PUBLIC WORKS

Contractor shall comply fully with the provisions of ORS 279C.800 through 279C.870. Documents establishing those conditions, as determined by the Commissioner of the Bureau of Labor and Industries (BOLI), are included as attachments to or are incorporated by reference in the Contract Documents. Pursuant to ORS 279C.830(1)(c), Contractor shall pay workers at not less than the specified minimum hourly rate of wage, and shall include that requirement in all subcontracts. If the Work is subject to both the state prevailing wage rate law and the federal Davis-Bacon Act, Contractor shall pay the higher of the applicable state or federal prevailing rate of wage. Contractor shall provide written notice to all workers of the number of hours per day and days per week such workers may be

required to work.

C.2 PAYROLL CERTIFICATION AND FEE REQUIREMENTS

C.2.1 In accordance with ORS 279C.845, the Contractor and every Subcontractor shall submit written certified statements to the Owner, on the form prescribed by the Commissioner of the Bureau of Labor and Industries, certifying the hourly rate of wage paid each worker which the Contractor or the Subcontractor has employed on the project and further certifying that no worker employed on the project has been paid less than the prevailing rate of wage or less than the minimum hourly rate of wage specified in the Contract, which certificate and statement shall be verified by the oath of the Contractor or the Subcontractor that the Contractor or Subcontractor has read the certified statement, that the Contractor or Subcontractor knows the contents of the certified statement, and, that to the Contractor's or Subcontractor's best knowledge and belief, the certified statement is true. The certified statements shall set out accurately and completely the payroll records for the prior week, including the name and address of each worker, the worker's correct classification, rate of pay, daily and weekly number of hours worked, deductions made, and actual wages paid. Certified statements for each week during which the Contractor or Subcontractor has employed a worker on the project shall be submitted once a month, by the fifth business day of the following month. The Contractor and Subcontractors shall preserve the certified statements for a period of ten (10) years from the date of completion of the Contract.

C.2.2 Pursuant to ORS 279C.845(7), the Owner shall retain 25 percent of any amount earned by the Contractor on this public works project until the Contractor has filed the certified statements required by section C.2.1. The Owner shall pay to the Contractor the amount retained under this subsection within 14 days after the Contractor files the required certified statements, regardless of whether a Subcontractor has failed to file certified statements.

C.2.3 Pursuant to ORS 279C.845(8), the Contractor shall retain 25 percent of any amount earned by a first-tier Subcontractor on this public works project until the first-tier Subcontractor has filed with the Owner the certified statements required by C.2.1. Before paying any amount retained under this subsection, the Contractor shall verify that the first-tier Subcontractor has filed the certified statement. Within 14 days after the first-tier Subcontractor files the required certified statement the Contractor shall pay the first-tier Subcontractor any amount retained under this subsection.

C.2.4 In accordance with statutory requirements and administrative rules promulgated by the Commissioner of the Bureau of Labor and Industries, the fee required by ORS 279C.825(1) will be paid by Owner to the Commissioner.

C.3 PROMPT PAYMENT AND CONTRACT CONDITIONS

C.3.1 As a condition to Owner's performance hereunder, the Contractor shall:

C.3.1.1 Make payment promptly, as due, to all persons supplying to Contractor labor or materials for the prosecution of the Work provided for in this Contract.

C.3.1.2 Pay all contributions or amounts due the State Industrial Accident Fund from such Contractor or Subcontractor incurred in the performance of the Contract.

C.3.1.3 not permit any lien or claim to be filed or prosecuted against the Owner on account of any labor or material furnished. Contractor will not assign any claims that Contractor has

against Owner, or assign any sums due by Owner, to Subcontractors, suppliers, or manufacturers, and will not make any agreement or act in any way to give Subcontractors a claim or standing to make a claim against the Owner.

C.3.1.4 Pay to the Department of Revenue all sums withheld from employees pursuant to ORS 316.167.

C.3.2 As a condition to Owner's performance hereunder, if Contractor fails, neglects or refuses to make prompt payment of any claim for labor or services furnished to the Contractor of a Subcontractor by any person in connection with the project as such claim becomes due, the proper officer(s) representing the Owner may pay the claim and charge the amount of the payment against funds due or to become due Contractor under this Contract. Payment of claims in this manner shall not relieve the Contractor or the Contractor's surety from obligation with respect to any unpaid claims.

C.3.3 Contractor shall include in each subcontract for property or services entered into by the Contractor and a first-tier subcontractor, including a material supplier, for the purpose of performing a construction contract, a payment clause that obligates the Contractor to pay the first-tier Subcontractor for satisfactory performance under its subcontract within ten (10) Days out of such amounts as are paid to the Contractor by the public contracting agency under such contract.

C.3.4 All employers, including Contractor, that employ subject workers who work under this contract in the State of Oregon shall comply with ORS 656.017 and provide the required Workers' Compensation coverage, unless such employers are exempt under ORS 656.126. Contractor shall ensure that each of its Subcontractors complies with these requirements.

C.4 PAYMENT FOR MEDICAL CARE

As a condition to Owner's performance hereunder, Contractor shall promptly, as due, make payment to any person, partnership, association or corporation furnishing medical, surgical, and hospital care or other needed care and attention, incident to sickness or injury, to the employees of such Contractor, all sums of which the Contractor agrees to pay for such services and all moneys and sums which the Contractor has collected or deducted from the wages of personnel pursuant to any law, contract or agreement for the purpose of providing or paying for such services.

C.5 HOURS OF LABOR

As a condition to Owner's performance hereunder, no person shall be employed to perform Work under this Contract for more than ten (10) hours in any one day or forty (40) hours in any one week, except in cases of necessity, emergency or where public policy absolutely requires it. In such instances, Contractor shall pay the employee at least time and a half pay:

(a) For all overtime in excess of eight (8) hours a day or forty (40) hours in any one week when the work week is five consecutive Days, Monday through Friday; or

(b) For all overtime in excess of ten (10) hours a day or forty (40) hours in any one week when the work week is four consecutive Days, Monday through Friday; and

(c) For all Work performed on Saturday and on any legal holiday specified in ORS 279C.540.

This section C.5 will not apply to Contractor's Work under this Contract to the extent Contractor is currently a party to a collective bargaining agreement with any labor organization.

This Section C.5 shall not excuse Contractor from completion of the Work within the time required under this Contract.

exceeded. Cost and price data relating to adjustments to or deletions from the Work shall be supplied by Contractor to Owner upon request, but Owner shall be under no obligation to make such requests.

**SECTION D
CHANGES IN THE WORK**

D.1 CHANGES IN WORK

D.1.1 The terms of this Contract shall not be waived, altered, modified, supplemented or amended in any manner whatsoever, without prior written agreement and then only after any necessary approvals have been obtained. A Supplement or Amendment is required, which shall not be effective until its execution by the parties to this Contract and all approvals required by public contracting laws have been obtained.

D.1.2 It is mutually agreed that changes in Plans, quantities, or details of construction are inherent in the nature of construction and may be necessary or desirable during the course of construction. Within the general scope of this Contract, the Owner may at any time, without notice to the sureties and without impairing the Contract, require changes consistent with this Section D.1. All changes to the Work shall be documented and Amendments shall be executed under the conditions of the Contract Documents. Such changes may include, but are not limited to:

- (a) Modification of specifications and design.
- (b) Increases or decreases in quantities.
- (c) Increases or decreases to the amount of Work.
- (d) Addition or elimination of any Work item.
- (e) Change in the duration of the project.
- (f) Acceleration or delay in performance of Work.
- (g) Deductive changes,
- (h) Changed conditions.

Deductive changes are those that reduce the scope of the Work, and shall be made by mutual agreement whenever feasible. In cases of suspension or partial termination under Section J, Owner reserves the right to unilaterally impose a deductive change and to self-perform such Work, for which the provisions of B.13 (Owner's Right to Do Work) shall then apply. Adjustments in compensation shall be made under the provisions of D.1.3, in which costs for deductive changes shall be based upon a Direct Costs adjustment together with the related percentage markup specified for profit, Overhead and other indirect costs, unless otherwise agreed to by Owner.

D.1.3 The Owner and Contractor agree that adjustments to or deletions from the Work shall be administered and compensated according to the following:

- (a) Unit pricing may be utilized at the Owner's option when unit prices or solicitation alternates were provided that established the cost for adjustments to Work, and a binding obligation exists under the Contract on the parties covering the terms and conditions of the adjustment to Work.
- (b) If the Owner elects not to utilize unit pricing, or in the event that unit pricing is not available or appropriate, fixed pricing may be used for adjustments to or deletions from the Work. In fixed pricing, the basis of payments or total price shall be agreed upon in writing between the parties to the Contract, and shall be established before the Work is done whenever feasible. Notwithstanding the foregoing, the mark-ups set forth in D.1.3(c) shall be utilized in establishing fixed pricing, and such mark-ups shall not be

(c) In the event that unit pricing and fixed pricing are not utilized, then adjustments to or deletions from the Work shall be performed on a cost reimbursement basis for Direct Costs. Such Work shall be compensated on the basis of the actual, reasonable and allowable cost of labor, equipment, and material furnished on the Work performed. In addition, the following markups shall be added to the Contractor's or Subcontractor's Direct Costs as full compensation for profit, Overhead and other indirect costs for Work directly performed with the Contractor's or Subcontractor's own forces:

On Labor.....	15%
On Equipment.....	10%
On Materials.....	10%

(d) When adjustments to or deletions from the Work under D.1.3(c) are invoiced by an authorized Subcontractor at any level, each ascending tier Subcontractor or Contractor will be allowed a supplemental mark-up on each piece of subcontract Work covered by an Amendment as follows:

\$0.00 - \$5,000.00	10%, and then
Over \$5,000.00	5%

Notwithstanding the foregoing, the maximum aggregate markup to be billed shall not exceed 10% regardless of the number of subcontract tiers

Payments made to the Contractor shall be complete compensation for Overhead, profit, and all costs that were incurred by the Contractor or by other forces furnished by the Contractor, including Subcontractors, for adjustments to or deletions from the Work pursuant to a Supplement Amendment. Owner may establish a maximum cost for additional Work under this Section D.1.3, which shall not be exceeded for reimbursement without additional written authorization from Owner in the form of a Supplement Amendment. Contractor shall not be required to complete such additional Work without additional authorization.

Any necessary adjustment of Contract Time that may be required as a result of adjustments to or deletions from the Work must be agreed upon by the parties before the start of the revised Work unless Owner authorizes Contractor to start the revised Work before agreement on Contract Time adjustment. Contractor shall submit any request for additional compensation (and additional Contract Time if Contractor was authorized to start Work before an adjustment of Contract Time was approved) as soon as possible but no later than thirty (30) Days after receipt of Owner's request for additional Work. Contractor agrees that this thirty (30) Day notice period is adequate time for it to request and document the amount of additional compensation or adjustment of Contract Time. If Contractor's request for additional compensation or adjustment of Contract Time is not made within the thirty (30) Day time limit, Contractor agrees its requests pertaining to that additional Work shall be barred. The thirty (30) Day time limit for making requests shall not be extended for any reason, including without limitation Contractor's claimed inability to determine the amount of additional compensation or adjustment of Contract Time, unless an extension is granted in writing by Owner. If the Owner denies Contractor's timely request for additional compensation or adjustment of Contract Time, Contractor may proceed to file a Claim under Section D.3, Claims Review Process. No other reimbursement, compensation, or payment

will be made, except as provided in Section D.1.5 for impact claims.

D.1.4 If any adjustment to Work under Section D.1.3 causes an increase or decrease in the Contractor's cost of, or the Contract Time required for the performance of any other part of the Work under this Contract, Contractor shall submit a written request to the Owner, setting forth the nature and specific extent of the request, including all time and cost impacts against the Contract as soon as possible, but no later than thirty (30) Days after receipt of Owner's request for adjustments to or deletions from the Work by Contractor.

The thirty (30) Day time limit applies to claims of Subcontractors, suppliers, or manufacturers who may be affected by Owner's request for adjustments to or deletions from the Work and who request additional compensation or an extension of Contract Time to perform; Contractor has responsibility for contacting its Subcontractors, suppliers, or manufacturers within the thirty (30) Day time limit, and including their requests with Contractor's requests. If the request involves Work to be completed by Subcontractors, or materials to be furnished by suppliers or manufacturers, such requests shall be submitted to the Contractor in writing with full analysis and justification for the adjustments to compensation and Contract Time requested. The Contractor shall analyze and evaluate the merits of the requests submitted by Subcontractors, suppliers, and manufacturers to Contractor prior to including those requests and Contractor's analysis and evaluation of those requests with Contractor's requests for adjustments to compensation or Contract Time that Contractor submits to the Owner. Failure of Subcontractors, suppliers, manufacturers or others to submit their requests to Contractor for inclusion with Contractor's requests submitted to Owner within the time period and by the means described in this section shall constitute a waiver of these Subcontractor claims. The Owner will not consider direct requests or claims from Subcontractors, suppliers, manufacturers or others not a party to this Contract. The consideration of such requests and claims under this section does not give any Person, not a party to the Contract the right to bring a claim against Owner, whether in this claims process, in litigation, or in any dispute resolution process.

If the Owner denies the Contractor's request for adjustment to compensation or Contract Time, and the request is timely as set forth herein, the Contractor may proceed to file a Claim under Section D.3, Claims Review Process.

D.1.5 Contractor agrees that no request or Claim for additional costs or an adjustment of Contract Time shall be allowed if made after receipt of Final Payment application under this Contract. Final Payment application must be made by Contractor within the time required under Section E.6.4.

D.1.6 It is understood that changes in the Work are inherent in construction of this type. The number of changes, the scope of those changes, and the effect they have on the progress of the original Work cannot be defined at this time. The Contractor is notified that numerous changes may be required and that there will be no compensation made, unless and only to the extent otherwise provided in the Contract Documents, to the Contractor directly related to the number of changes. Each change will be evaluated for extension of Contract Time and increase or decrease in compensation based on its own merit.

D.2 DELAYS

D.2.1 Delays in construction include "Avoidable Delays", which are defined in Section D.2.1.1, and "Unavoidable Delays", which are defined in Section D.2.1.2. The effect of Avoidable Delays is described in Section D.2.2 and the effect of Unavoidable Delays is described in Section D.2.3.

D.2.1.1 Avoidable Delays include any delays other than Unavoidable Delays, and include delays that otherwise would be considered Unavoidable Delays but that:

- (a) Could have been avoided by the exercise of care, prudence, foresight, and diligence on the part of the Contractor or its Subcontractors.
- (b) Affect only a portion of the Work and do not necessarily prevent or delay the prosecution of other parts of the Work or the completion of the whole Work within the Contract Time.
- (c) Do not impact activities on the accepted CPM Construction Schedule.
- (d) Are associated with the reasonable interference of other contractors employed by the Owner that do not necessarily prevent the completion of the whole Work within the Contract Time.

D.2.1.2 Unavoidable Delays include delays other than Avoidable Delays that are:

- (a) To the extent caused by any actions of the Owner, or any other employee or agent of the Owner, or by separate contractor employed by the Owner.
- (b) To the extent caused by any site conditions that differ materially from what was represented in the Contract Documents or from conditions that would normally be expected to exist and be inherent to the construction activities defined in the Contract Documents. The Contractor agrees to notify the Owner immediately of differing site conditions before the area has been disturbed. The Owner will investigate the area and make a determination as to whether the conditions differ materially from either the conditions stated in the Contract Documents or those that could reasonably be expected in execution of this particular Contract. If Contractor and Owner agree that a differing site condition exists, any adjustment to compensation or Contract Time will be determined based on the process set forth in Section D.1.5 for adjustments to or deletions from Work. If the Owner disagrees that a differing site condition exists and denies Contractor's request for additional compensation or Contract Time, Contractor may proceed to file a Claim under Section D.3, Claims Review Process.
- (c) To the extent caused by Force Majeure acts, events or occurrences that could not have been avoided by the exercise of care, prudence, foresight, and diligence on the part of the Contractor or its Subcontractors.
- (d) To the extent caused by adverse weather conditions. Any adverse weather conditions must be substantiated by documentary evidence that weather conditions were abnormal for the specific time period claimed, could not have been anticipated by the Contractor, and adversely impacted the Project in a manner that could not be avoided by rescheduling the Work or by implementing measures to protect against the weather so that the Work could proceed. A rain, windstorm, high water, or other natural phenomenon for the specific locality of the Work, which might reasonably have been anticipated from the previous 10-year historical records of the general locality of the Work, shall not be construed as abnormal. The parties agree that rainfall greater than the following levels cannot be reasonably anticipated:

- (i) Daily rainfall equal to, or greater than, 0.50 inch during a month when the monthly rainfall exceeds the normal monthly average by twenty-five percent (25 %) or more.
- (ii) daily rainfall equal to, or greater than, 0.75 inch at any time.

The Office of the Environmental Data Service of the National Oceanic and Atmospheric Administration of the U.S. Department of Commerce nearest the Project site shall be considered the official agency of record for weather information.

D.2.2 Contractor agrees it is not be entitled to additional compensation or additional Contract Time for Avoidable Delays.

D.2.3 In the event of Unavoidable Delays, based on principles of equitable adjustment, Contractor may be entitled to the following:

- (a) Contractor may be entitled to additional compensation or additional Contract Time, or both, for Unavoidable Delays described in Section D.2.1.2 (a) and (b).
- (b) Contractor may be entitled to additional Contract Time for Unavoidable Delays described in Section D.2.1.2(c) and (d).

In the event of any requests for additional compensation or additional Contract Time, or both, as applicable, arising under this Section D.2.3 for Unavoidable Delays, other than requests for additional compensation or additional Contract Time for differing site conditions for which a review process is established under Section D.2.1.2 (b), Contractor must submit a written notification of the delay to the Owner within two (2) Days of the occurrence of the cause of the delay. This written notification shall state the cause of the potential delay, the project components impacted by the delay, and the anticipated additional Contract Time extension or the additional compensation, or both, as applicable, resulting from the delay. Within seven (7) Days after the cause of the delay has been mitigated, or in no case more than thirty (30) Days after the initial written notification, the Contractor agrees to submit to the Owner, a complete and detailed request for additional compensation or additional Contract Time, or both, as applicable, resulting from the delay. If the Owner denies Contractor's request for additional compensation or adjustment of Contract Time, the Contractor may proceed to file a Claim under Section D.3, Claims Review Process, provided Contractor has complied with the requirement in this Section D.2.3. Contractor agrees any Claim it may have is barred if Contractor does not comply with the requirements herein.

If Contractor does not timely submit the notices required under this Section D.2, then unless otherwise prohibited by law, Contractor's Claim shall be barred.

D.3 CLAIMS REVIEW PROCESS

D.3.1 All Contractor Claims shall be referred to the Owner for review. Contractor's Claims, including Claims for adjustments to compensation or Contract Time, shall be submitted in writing by Contractor to the Owner within five (5) Days after a denial of Contractor's initial request for an adjustment of Contract terms, payment of money, extension of Contract Time or other relief, provided that such initial request has been submitted in accordance with the requirements and within the time limits established in these Retainer General Conditions. Within thirty (30) Days after the initial Claim, Contractor shall submit to the Owner a complete and detailed description of the Claim (the "Detailed Notice") that includes all information required by Section D.3.2. Contractor agrees that, unless the Claim is made

in accordance with these time requirements, Contractor voluntarily waived all rights to prosecute its Claim.

D.3.2 The Detailed Notice of the Claim shall be submitted in writing by Contractor and shall include a detailed, factual statement of the basis of the Claim, pertinent dates, Contract provisions which support or allow the Claim, reference to or copies of any documents which support the Claim, the dollar value of the Claim, and the Contract Time adjustment requested for the Claim. If the Claim involves Work to be completed by Subcontractors, the Contractor will analyze and evaluate the merits of the Subcontractor claim prior to forwarding it and that analysis and evaluation to the Owner. The Owner will not consider direct claims from Subcontractors, suppliers, manufacturers, or others not a party to this Contract. Contractor agrees that it will make no agreement, covenant, or assignment, nor will it commit any other act that will permit or assist any Subcontractor, supplier, manufacturer, or other to directly or indirectly make a claim against Owner.

D.3.3 The Owner will review all Claims and take one or more of the following preliminary actions within ten (10) Days of receipt of the Detailed Notice of a Claim: (1) request additional supporting information from the Contractor; (2) inform the Contractor and Owner in writing of the time required for adequate review and response; (3) reject the Claim in whole or in part and identify the reasons for rejection; (4) based on principles of equitable adjustment, recommend approval of all or part of the Claim; or (5) propose an alternate resolution.

D.3.4 The Owner's decision shall be final and binding on the Contractor unless appealed by written notice to the Owner within fifteen (15) Days of receipt of the decision. The Contractor must present written documentation supporting the Claim within fifteen (15) Days of the notice of appeal. After receiving the appeal documentation, the Owner shall review the materials and render a decision within thirty (30) Days after receiving the appeal documents.

D.3.5 The decision of the Owner shall be final and binding unless the Contractor delivers to the Owner its request for mediation, which shall be a non-binding process, within fifteen (15) Days of the date of the Owner's decision. The mediation process will be considered to have commenced as of the date the Contractor delivers the request. Both parties acknowledge and agree that participation in mediation is a prerequisite to commencement of litigation of any disputes relating to the Contract. Both parties further agree to exercise their best efforts in good faith to resolve all disputes within sixty (60) Days of the commencement of the mediation through the mediation process set forth herein.

In the event that a lawsuit must be filed within this sixty (60) Day period in order to preserve a cause of action, the parties agree that, notwithstanding the filing, they shall proceed diligently with the mediation to its conclusion prior to actively prosecuting the lawsuit, and shall seek from the Court in which the lawsuit is pending such stays or extensions, including the filing of an answer, as may be necessary to facilitate the mediation process. Further, in the event settlements are reached on any issues through mediation, the plaintiff shall promptly cause to be entered by the Court a stipulated general judgment of dismissal with prejudice, or other appropriate order limiting the scope of litigation as provided in the settlement.

D.3.6 Should the parties arrive at an impasse regarding any Claims or disputed Claims, it is agreed that the parties shall participate in mediation as specified in Section D.3.5. The mediation process will be considered to have been commenced as of the date one party delivers to the other its request in writing to mediate. The mediator shall be an individual mutually acceptable to both parties, but in the absence of agreement each party shall select a

temporary mediator and the temporary mediators shall jointly select the permanent mediator. Each party shall pay its own costs for the time and effort involved in mediation. The cost of the mediator shall be split equally between the two parties. Both parties agree to exercise their best effort in good faith to resolve all disputes in mediation. Participation in mediation is a mandatory requirement of both the Owner and the Contractor. The schedule, time and place for mediation will be mutually acceptable, or, failing mutual agreement, shall be as established by the mediator. The parties agree to comply with Owner's administrative rules governing the confidentiality of mediation, if any, and shall execute all necessary documents to give effect to such confidentiality rules. In any event, the parties shall not subpoena the mediator or otherwise require the mediator to produce records, notes or work product, or to testify in any future proceedings as to information disclosed or representations made in the course of mediation, except to the extent disclosure is required by law.

D.3.7 Unless otherwise directed by Owner, Contractor shall proceed with the Work while any Claim, or mediation or litigation arising from a Claim, is pending. Regardless of the review period or the final decision of the Owner, the Contractor shall continue to diligently pursue the Work as identified in the Contract Documents. In no case is the Contractor justified or allowed to cease or Delay Work, in whole or in part, without a written stop work order from the Owner.

SECTION E PAYMENTS

E.1 SCHEDULE OF VALUES

The Contractor shall submit, at least ten (10) Days prior to submission of its first application for progress payment, a schedule of values ("Schedule of Values") for the contracted Work. This schedule shall provide a breakdown of values for the contracted Work and will be the basis for progress payments. The breakdown shall demonstrate reasonable, identifiable, and measurable components of the Work. Unless objected to by the Owner, this schedule shall be used as the basis for reviewing Contractor's applications for payment. If objected to by Owner, Contractor shall revise the schedule of values and resubmit the same for approval of Owner.

E.2 APPLICATIONS FOR PAYMENT

E.2.1 Owner shall make progress payments on the Contract monthly as Work progresses, in accordance with the requirements of this Section E.2. Applications for payment shall be based upon estimates of Work completed and the Schedule of Values. As a condition precedent to Owner's obligation to pay, all applications for payment shall be approved by the Owner. A progress payment shall not be considered acceptance or approval of any Work or waiver of any defects therein. Owner shall pay to Contractor interest for overdue invoices at the rate of two-thirds of one percent per month on the progress payment, not including retainage, due the Contractor. Overdue invoices will be those that have not been paid within forty five (45) days from the latest of:

- (a) The date of the receipt of the accurate invoice;
- (b) The date Owner receives the correct application for payment if no invoice is received;
- (c) The date all goods and services have been received; or
- (d) The date a Claim is made certain by agreement of the parties or by operation of law.

Notwithstanding the foregoing, in instances when an application for payment is filled out incorrectly, or when there is any defect

or impropriety in any submitted application or when there is a good faith dispute, Owner shall so notify the Contractor within fifteen (15) Days stating the reason or reasons the application for payment is defective or improper or the reasons for the dispute. A defective or improper application for payment, if corrected by the Contractor within seven (7) Days of being notified by the Owner, shall not cause a payment to be made later than specified in this section unless interest is also paid. Payment of interest will be postponed when payment on the principal is delayed because of disagreement between the Owner and the Contractor.

Owner reserves the right, instead of requiring the Contractor to correct or resubmit a defective or improper application for payment, to reject the defective or improper portion of the application for payment and pay the remainder of the application for such amounts which are correct and proper.

Owner, upon written notice to the Contractor, may elect to make payments to the Contractor only by means of Electronic Funds Transfers (EFT) through Automated Clearing House (ACH) payments. If Owner makes this election, the Contractor shall arrange for receipt of the EFT/ACH payments.

E.2.2 Contractor shall submit to the Owner an application for each payment and, if required, receipts or other vouchers showing payments for materials and labor including payments to Subcontractors. Contractor shall include in its application for payment a schedule of the percentages of the various parts of the Work completed, based on the Schedule of Values which shall aggregate to the payment application total, and shall include, on the face of each copy thereof, a certificate in substantially the following form:

"I, the undersigned, hereby certify that the above bill is true and correct, and the payment therefore, has not been received.

Signed: _____
Dated: _____"

E.2.3 Generally, applications for payment will be accepted only for materials that have been installed. Under special conditions, applications for payment for stored materials will be accepted at Owner's sole discretion. Such a payment, if made, will be subject to the following conditions:

- (a) The request for stored material shall be submitted at least thirty (30) Days in advance of the application for payment on which it appears. Applications for payment shall be entertained for major equipment, components or expenditures only.
- (b) The Contractor shall submit applications for payment showing the quantity and cost of the material stored.
- (c) The material shall be stored in a bonded warehouse and Owner shall be granted the right to access the material for the purpose of removal or inspection at any time during the Contract Period.
- (d) The Contractor shall name the Owner as co-insured on the insurance policy covering the full value of the property while in the care and custody of the Contractor until it is installed. A certificate noting this coverage shall be issued to the Owner.
- (e) Payments shall be made for materials and equipment only. The submitted amount in the application for payment shall be reduced by the cost of transportation from the storage site to the project site and for the cost of an inspector to verify delivery and condition of the goods at the storage site. The cost of storage and inspection shall be borne solely by the Contractor.

(f) Within sixty (60) Days of the application for payment, the Contractor shall submit evidence of payment covering the material and/or equipment stored and of payment for the storage site.

(g) Payment for stored materials and/or equipment shall in no way indicate acceptance of the materials and/or equipment or waive any rights under this Contract for the rejection of the Work or materials and/or equipment not in conformance with the Contract Documents.

(h) All required documentation shall be submitted with the respective application for payment.

E.2.4 The Owner reserves the right to withhold all or part of a payment, or may nullify in whole or part any payment previously made, to such extent as may be necessary in the Owner's opinion to protect the Owner from loss because of:

- (a) Work that is defective and not remedied, or that has been demonstrated or identified as failing to conform with Applicable Laws or the Contract Documents,
- (b) Third party claims filed or evidence reasonably indicating that such claims will likely be filed unless security acceptable to the Owner is provided by the Contractor;
- (c) Failure of the Contractor to make payments properly to Subcontractors or for labor, materials or equipment (in which case Owner may issue checks made payable jointly to Contractor and such unpaid persons under this provision, or directly to Subcontractors and suppliers at any level under Section C.3.2.);
- (d) Reasonable evidence that the Work cannot be completed for the unpaid balance of the Contract Price;
- (e) Damage to the Work, Owner or another contractor;
- (f) Reasonable evidence that the Work will not be completed within the Contract Time required by the Contract, and that the unpaid balance would not be adequate to cover actual or liquidated damages for the anticipated delay;
- (g) Failure to carry out the Work in accordance with the Contract Documents; or
- (h) Assessment of liquidated damages, when withholding is made for offset purposes.

E.2.5 Subject to the provisions of the Contract Documents, the amount of each progress payment shall be computed as follows:

- (a) Take that portion of the Contract Price properly allocable to completed Work as determined by multiplying the percentage completion of each portion of the Work by the share of the total Contract Price allocated to that portion of the Work in the Schedule of Values, less retainage as provided in Section E.5. Pending final determination of cost to the Owner of changes in the Work, no amounts for changes in the Work can be included in applications for payment until the Contract Price has been adjusted by a Supplement Amendment;
- (b) Add that portion of the Contract Price properly allocable to materials and equipment delivered and suitably stored at the site for subsequent incorporation in the completed construction (or, if approved in advance by the Owner pursuant to Section E.2.3, suitably stored off the site at a location agreed upon in writing), less retainage as provided in Section E.5;

(c) Subtract the aggregate of previous payments made by the Owner; and

(d) Subtract any amounts for which the Owner has withheld or nullified payment as provided in the Contract Documents.

E.2.6 Contractor's applications for payment shall not include requests for payment for portions of the Work for which the Contractor does not intend to pay to a Subcontractor or material supplier.

E.2.7 The Contractor warrants to Owner that title to all Work covered by an application for payment will pass to the Owner no later than the time of payment. The Contractor further warrants that upon submittal of an application for payment all Work for which payments are received from the Owner shall be free and clear of liens, claims, security interests or encumbrances in favor of the Contractor, Subcontractors, material suppliers, or other persons or entities making a claim by reason of having provided financing, labor, materials and equipment relating to the Work.

E.2.8 If Contractor disputes any determination by Owner with regard to any application for payment, Contractor nevertheless shall continue to expeditiously perform the Work. No payment made hereunder shall be or be construed to be final acceptance or approval of that portion of the Work to which such partial payment relates or shall relieve Contractor of any of its obligations hereunder.

E.2.9 Contractor shall submit its initial MWESB Report within ten (10) Days of Contractor's execution of the Contract, or if there will be a Guaranteed Maximum Price (GMP) Amendment, then within ten (10) Days of Contractor's execution of the GMP Amendment. Contractor shall submit annual MWESB Reports on June 30 of each year the Contract is active. Contracts (or GMP Amendments) first executed by Contractor within ninety (90) Days before June 30 of the year of execution by Contractor may at the discretion of Owner be exempt from submitting the annual MWESB Report otherwise due on that June 30. The final MWESB Report shall be filed with the application for final payment. Timely receipt of MWESB Reports by Owner shall be a condition precedent to Owner's obligation to pay any progress payments or final payment otherwise due.

E.3 PAYROLL CERTIFICATION REQUIREMENT

Owner's receipt of payroll certification pursuant to Section C.2 of this Contract shall be a condition precedent to Owner's obligation to pay any progress payments or final payment otherwise due.

E.4 DUAL PAYMENT SOURCES

Contractor shall not be compensated for Work performed under this Contract from any state agency other than the agency that is a party to this Contract.

E.5 RETAINAGE

E.5.1 Retainage shall be withheld and released in accordance with the requirements set forth in OSU standards and policies.

E.5.1.1 Owner may reserve as retainage from any progress payment an amount not to exceed five percent of the payment. As Work progresses, Owner may reduce the amount of retainage on or may eliminate retainage on any remaining monthly Contract payments after 50 percent of the Work under the Contract is completed if, in the Owner's discretion, such Work is progressing satisfactorily. Elimination or reduction of retainage shall be allowed only at Owner's sole discretion and only upon written application by the Contractor, which application shall include written approval of Contractor's surety; except that when the Work is 97-1/2 percent completed the Owner may, at its discretion and without application by the Contractor, reduce the

retained amount to 100 percent of the value of the Work remaining to be done. Upon receipt of written application by the Contractor, Owner shall respond in writing within a reasonable time.

E.5.1.2 Contractor may request in writing:

- (a) To be paid amounts which would otherwise have been retained from progress payments where Contractor has deposited acceptable bonds and securities of equal value with Owner or in a custodial account or other mutually-agreed account satisfactory to Owner, with an approved bank or trust company to be held in lieu of the cash retainage for the benefit of Owner;
- (b) For construction projects over \$1,000,000, that retainage be deposited in an interest bearing account, established through the State Treasurer for state agencies, in a bank, savings bank, trust company or savings association for the benefit of Owner, with earnings from such account accruing to the Contractor; or
- (c) That the Owner allow Contractor to deposit a surety bond for the benefit of Owner, in a form acceptable to Owner, in lieu of all or a portion of funds retained, or to be retained. Such bond and any proceeds therefrom shall be made subject to all claims in the manner and priority as set forth for retainage.

When the Owner has accepted the Contractor's election of option (a) or (b), Owner may recover from Contractor any additional costs incurred through such election by reducing Contractor's final payment. Where the Owner has agreed to Contractor's request for option (c), Contractor shall accept like bonds from Subcontractors and suppliers on the project from which Contractor has required retainages.

E. 5.1.3 The retainage held by Owner shall be included in and paid to the Contractor as part of the Final Payment of the Contract Price. The Owner shall pay to Contractor interest at the rate of two-thirds of one percent per month on the final payment due Contractor, interest to commence forty five (45) Days after the date which Owner receives Contractor's final approved application for payment and Work under the Contract has been completed and accepted and to run until the date when final payment is tendered to Contractor. The Contractor shall notify Owner in writing when the Contractor considers the Work complete and deliver to Owner its final application for payment and Owner shall, within fifteen (15) Days after receiving the written notice and the application for payment, either accept the Work or notify the Contractor of Work yet to be performed on the Contract. If Owner does not within the time allowed notify the Contractor of Work yet to be performed to fulfill contractual obligations, the interest provided by this subsection shall commence to run forty five (45) Days after the end of the 15-Day period.

E.5.1.4 Owner will reduce the amount of the retainage if the Contractor notifies the controller of the Owner that the Contractor has deposited in an escrow account with a bank or trust company, in a manner authorized by the Owner, bonds and securities of equal value of a kind approved by the Owner and such bonds and securities have in fact been deposited.

E.5.1.5 Contractor agrees that if Contractor elects to reserve a retainage from any progress payment due to any Subcontractor or supplier, such retainage shall not exceed five percent of the payment, and such retainage withheld from Subcontractors and suppliers shall be subject to the same terms and conditions stated in Subsection E.5 as apply to Owner's retainage from any progress payment due to Contractor.

E.6 FINAL PAYMENT

E.6.1 Upon completion of all the Work under this Contract, the Contractor shall notify the Owner, in writing, that Contractor has completed Contractor's obligations under the Contract and shall prepare its application requesting final payment. Upon receipt of such notice and application for payment, the Owner will inspect the Work, and, if acceptable, submit to the Owner a recommendation as to acceptance of the completed Work and the final estimate of the amount due the Contractor. If the Work is not acceptable, Owner will notify Contractor within fifteen (15) Days of Contractor's request for Final Payment. Upon approval of this final application for payment by the Owner and compliance by the Contractor with provisions in Section K, and Contractor's satisfaction of other provisions of the Contract Documents as may be applicable, the Owner shall pay to the Contractor all monies due under the provisions of these Contract Documents.

E.6.2 Neither Final Payment nor any remaining retained percentage shall become due until the Contractor submits to the Owner (1) a certificate evidencing that insurance required by the Contract Documents to remain in force after Final Payment is currently in effect and will not be canceled or allowed to expire until at least thirty (30) Days' prior written notice has been given to the Owner, (2) a written statement that the Contractor knows of no substantial reason that the insurance will not be renewable to cover the period required by the Contract Documents, (3) consent of surety, if any, to Final Payment and (4), if required by the Owner, other data establishing payment or satisfaction of obligations, such as receipts, releases and waivers of liens, claims, security interests or encumbrances arising out of the Contract, to the extent and in such form as may be designated by the Owner. If a Subcontractor refuses to furnish a release or waiver required by the Owner, the Contractor may furnish a bond satisfactory to the Owner to indemnify the Owner against such lien. If such lien remains unsatisfied after payments are made, the Contractor shall refund to the Owner all money that the Owner may be compelled to pay in discharging such lien, including all costs and reasonable attorneys' fees.

E.6.3 Acceptance of Final Payment by the Contractor, a Subcontractor or material supplier shall constitute a waiver of claims by that payee except those previously made in writing and identified by that payee as unsettled at the time of final application for payment.

E.6.4 Contractor agrees to submit its final payment application within ninety (90) Days after Substantial Completion, unless written extension is granted by Owner. Contractor shall not delay Final Payment application for any reason, including without limitation nonpayment of Subcontractors, suppliers, manufacturers or others not a party to this Contract, or lack of resolution of a dispute with Owner or any other person of matters arising out of or relating to the Contract. If Contractor fails to submit its Final Payment application within ninety (90) Days after Substantial Completion, and Contractor has not obtained written extension by Owner, all requests or Claims for additional costs or an extension of Contract Time shall be waived.

SECTION F JOB SITE CONDITIONS

F.1 USE OF PREMISES

Contractor shall confine equipment, storage of materials and operation of Work to the limits indicated by Contract Documents, Applicable Laws, permits or directions of the Owner. Contractor shall follow the Owner's instructions regarding use of premises, if any.

F.2 PROTECTION OF WORKERS, PROPERTY AND THE PUBLIC

F.2.1 Contractor shall maintain continuous and adequate protection of all of the Work from damage and shall protect the Owner, workers and property from injury or loss arising in connection with this Contract. Contractor shall remedy acceptably to the Owner any damage, injury, or loss, except such as may be directly due to errors in the Contract Documents or caused by authorized representatives or personnel of the Owner. Contractor shall adequately protect adjacent property as provided by law and the Contract Documents.

F.2.2 Contractor shall take all necessary precautions for the safety of all personnel on the job site or otherwise engaged in the undertaking of the Work and shall comply with the Contract Documents, best practices and all applicable provisions of federal, state and municipal safety laws and building codes to prevent accidents or injury to persons on, about or adjacent to the premises where the Work is being performed. Contractor shall erect and properly maintain at all times, as required by the conditions and progress of the Work, all necessary safeguards for protection of workers and the public against any hazards created by construction. Contractor shall designate a responsible employee or associate on the Work site, whose duty shall be the prevention of accidents. The name and position of the person designated shall be reported to the Owner. The Owner has no responsibility for Work site safety. Work site safety shall be the responsibility of the Contractor.

F.2.3 Contractor shall not enter upon private property without first obtaining permission from the property owner or its duly authorized representative. Contractor shall be responsible for the preservation of all public and private property along and adjacent to the Work contemplated under the Contract and shall use every precaution necessary to prevent damage thereto. In the event the Contractor damages any property, the Contractor shall at once notify the property owner and make, or arrange to make, full restitution. Contractor shall, immediately and in writing, report to the Owner, all pertinent facts relating to such property damage and the ultimate disposition of the claim for damage.

F.2.4 Contractor shall be responsible for protection of adjacent work areas including impacts brought about by activities, equipment, labor, utilities, vehicles and materials on the site.

Contractor shall verify that all mechanical or electrical equipment in the construction areas that may be affected by the Work is in working order and shall notify the Owner, in writing, of any equipment not in working order prior to the start of the Work. Start of Work will be considered as acknowledgement that all equipment is in good working order. Contractor shall be required to restore equipment to its original, or better, condition upon completion of the project.

F.2.5 Contractor shall at all times direct its activities in such a manner as to minimize adverse effects on the environment. Handling of all materials shall be conducted so no release will occur that may pollute or become hazardous.

F.2.6 In an emergency affecting the safety of life or limb or of the Work or of adjoining property, the Contractor, without special instruction or authorization from the Owner, shall act reasonably to prevent threatened loss or injury, and shall so act, without appeal, if instructed by the Owner. Any compensation claimed by the Contractor on account of emergency work shall be determined in accordance with section D.

F.3 CUTTING AND PATCHING

F.3.1 Contractor shall be responsible for coordinating all cutting, fitting, or patching of the Work to make its several parts come together properly and fit to receive or be received by work of

other contractors or Subcontractors shown upon, or reasonably implied by, the Contract Documents.

F.3.2 Contractor shall be responsible for restoring all cut, fitted, or patched surfaces to an original condition; provided, however, that if a different condition is specified in the Contract Documents, then Contractor shall be responsible for restoring such surfaces to the condition specified in the Contract Documents.

F.4 CLEANING UP

From time to time as may be prudent or ordered by the Owner and, in any event, immediately after completion of the Work, the Contractor shall, at its own expense, clean up and remove all refuse and unused materials of any kind resulting from the Work. If Contractor fails to do so within twenty-four hours after notification by the Owner the work may be done by others and the cost charged to the Contractor and deducted from payment due the Contractor.

F.5 ENVIRONMENTAL CONTAMINATION

F.5.1 Contractor shall be held responsible for and shall indemnify, defend (with counsel of Owner's choice), and hold harmless Owner from and against any costs, expenses, damages, claims, and causes of action, (including attorney fees), or any of them, resulting from all spills, releases, discharges, leaks and disposal of environmental pollution, including storage, transportation, and handling during the performance of the Work or Contractor's obligations under the Contract which occur as a result of, or are contributed by, the negligence or actions of Contractor or its personnel, agents, or Subcontractors or any failure to perform in accordance with the Contract Documents (except to the extent otherwise void under ORS 30.140). Nothing in this section F.5.1 shall limit Contractor's responsibility for obtaining insurance coverages required under Section G.3 of this Contract, and Contractor shall take no action that would void or impair such coverages.

F.5.1.1 Contractor agrees to promptly dispose of such spills, releases, discharge or leaks to the satisfaction of Owner and regulatory agencies having jurisdiction in a manner that complies with Applicable Laws. Cleanup shall be at no cost to the Owner and shall be performed by properly qualified and, if applicable, licensed personnel.

F.5.1.2 Contractor shall obtain the Owner's written consent prior to bringing onto the Work site any (i) environmental pollutants or (ii) hazardous substances or materials, as the same or reasonably similar terms are used in any Applicable Laws. Notwithstanding such written consent from the Owner, the Contractor, at all times, shall:

- (a) Properly handle, use and dispose of all environmental pollutants and hazardous substances or materials brought onto the Work site, in accordance with all Applicable Laws;
- (b) Be responsible for any and all spills, releases, discharges, or leaks of (or from) environmental pollutants or hazardous substances or materials which Contractor has brought onto the Work site; and
- (c) Promptly clean up and remediate, without cost to the Owner, such spills, releases, discharges, or leaks to the Owner's satisfaction and in compliance with all Applicable Laws.

F.5.2 Contractor shall report all reportable quantity releases, as such releases are defined in Applicable Laws, including but not limited to 40 CFR Part 302, Table 302.4 and in OAR 340-142-0050, to applicable federal, state, and local regulatory and

emergency response agencies. Upon discovery, regardless of quantity, Contractor must telephonically report all releases to the Owner. A written follow-up report shall be submitted to Owner within 48 hours of the telephonic report. Such written report shall contain, as a minimum:

- (a) Description of items released (identity, quantity, manifest numbers, and any and all other documentation required by law.)
- (b) Whether amount of items released is EPA/DEQ reportable, and, if so, when reported.
- (c) Exact time and location of release, including a description of the area involved.
- (d) Containment procedures initiated.
- (e) Summary of communications about the release between Contractor and members of the press or State, local or federal officials other than Owner.
- (f) Description of cleanup procedures employed or to be employed at the site, including disposal location of spill residue.
- (g) Personal injuries, if any, resulting from, or aggravated by, the release.

F.6 ENVIRONMENTAL CLEAN-UP

F.6.1 Unless disposition of environmental pollution is specifically a part of this Contract, or was caused by the Contractor (reference F.5 Environmental Contamination), Contractor shall immediately notify Owner of any hazardous substance(s) which Contractor discovers or encounters during performance of the Work required by this Contract. "Hazardous substance(s)" means any hazardous, toxic and radioactive materials and those substances defined as "hazardous substances," "hazardous materials," "hazardous wastes," "toxic substances," or other similar designations in any federal, state, or local law, regulation, or ordinance, including without limitation asbestos, polychlorinated biphenyl (PCB), or petroleum, and any substances, materials or wastes regulated by 40 CFR, Part 261 and defined as hazardous in 40 CFR S 261.3. In addition to notifying Owner of any hazardous substance(s) discovered or encountered, Contractor shall immediately cease working in any particular area of the project where a hazardous substance(s) has been discovered or encountered if continued work in such area would present a risk or danger to the health or well-being of Contractor's or any Subcontractor's work force, property or the environment.

F.6.2 Upon being notified by Contractor of the presence of hazardous substance(s) on the project site, Owner shall arrange for the proper disposition of such hazardous substance(s).

F.7 FORCE MAJEURE

A party to this Contract shall not be held responsible for delay or default due to Force Majeure acts, events or occurrences unless they could have been avoided by the exercise of reasonable care, prudence, foresight, and diligence by that party. The Owner may terminate this Contract upon written notice after determining that delay or default caused by Force Majeure acts, events or occurrences will reasonably prevent successful performance of the Contract.

SECTION G INDEMNITY, BONDING, AND INSURANCE

G.1 RESPONSIBILITY FOR DAMAGES / INDEMNITY

G.1.1 Contractor shall be responsible for all damage to property, injury to persons, and loss, expense, inconvenience, and delay that may be caused by, or result from, the carrying out of the Work to be done under this Contract, or from any act, omission or neglect of the Contractor, its Subcontractors, sub-subcontractors of any tier, suppliers, employees, guests, visitors, invitees and agents.

G.1.2 To the fullest extent permitted by law, Contractor shall indemnify, defend (with counsel approved by Owner) and hold harmless the Owner, Architect/Engineer, Architect/Engineer's consultants, and their respective officers, directors, agents, employees, partners, members, stockholders and affiliated companies (collectively "Indemnitees") from and against all liabilities, damages, losses, claims, expenses (including reasonable attorney fees), demands and actions of any nature whatsoever which arise out of, result from or are related to, (a) any damage, injury, loss, expense, inconvenience or delay described in this Section G.1., (b) any accident or occurrence which happens or is alleged to have happened in or about the project site or any place where the Work is being performed, or in the vicinity of either, at any time prior to the time the Work is fully completed in all respects, (c) any failure of the Contractor or its Subcontractors, sub-subcontractors of any tier, suppliers, employees or consultants to observe or perform any duty or obligation under the Contract Documents which is to be observed or performed by the Contractor, or any breach of any agreement, representation or warranty of the Contractor contained in the Contract Documents or in any subcontract, (d) the negligent acts or omissions of the Contractor, a Subcontractor, sub-subcontractor of any tier suppliers, a consultant or anyone directly or indirectly employed by them or any one of them or anyone for whose acts they may be liable, regardless of whether or not such claim, damage, loss or expense is caused in part by a party indemnified hereunder (except to the extent otherwise void under ORS 30.140), and (e) any lien filed upon the project or bond claim in connection with the Work. Such obligation shall not be construed to negate, abridge, or reduce other rights or obligations of indemnity which would otherwise exist as to a party or person described in this Section G.1.2.

G.1.3 In claims against any person or entity indemnified under Section G.1.2 by an employee of the Contractor, a Subcontractor, anyone directly or indirectly employed by them or anyone for whose acts they may be liable, the indemnification obligation under Section G.1.2 shall not be limited by a limitation on amount or type of damages, compensation or benefits payable by or for the Contractor or a Subcontractor under workers' compensation acts, disability benefit acts or other employee benefit acts.

G.2 PERFORMANCE AND PAYMENT SECURITY; PUBLIC WORKS BOND

G.2.1 When the Contract Price is \$100,000 or more (or \$50,000 or more in the case of Contracts for highways, bridges and other transportation projects), the Contractor shall furnish and maintain in effect at all times during the Contract Period a performance bond in a sum equal to the Contract Price and a separate payment bond also in a sum equal to the Contract Price. Contractor shall furnish such bonds even if the Contract Price is less than the above thresholds if otherwise required by the Contract Documents.

G.2.2 Bond forms furnished by the Owner and notarized by awarded Contractor's surety company authorized to do business in Oregon are the only acceptable forms of performance and payment security, unless otherwise specified in the Contract Documents.

G.2.3 Before execution of the Contract the Contractor shall file with the Construction Contractors Board, and maintain in full force

and effect, the separate public works bond required by Oregon Laws 2015, Chapter 279C, and OAR 839-025-0015, unless otherwise exempt under those provisions. The Contractor shall also include in every subcontract a provision requiring the Subcontractor to have a public works bond filed with the Construction Contractors Board before starting Work, unless otherwise exempt, and shall verify that the Subcontractor has filed a public works bond before permitting any Subcontractor to start Work.

G.3 INSURANCE

G.3.1 General Requirements. The required insurance amounts set forth below do not in any way limit the amount or scope of liability of Contractor under this Contract. The amounts listed indicate only the minimum amounts of insurance coverage Owner is willing to accept to help insure full performance of all terms and conditions of this Contract.

G.3.1.1 Primary Coverage and Non-Contributory Coverage. Insurance carried by Contractor under this Contract shall be primary and non-contributory coverage. The coverages indicated are minimums unless otherwise specified in the Contract Documents.

G.3.1.2 Company Ratings. All policies of insurance must be written by companies having an A.M. Best rating of no less than "A-VII", or equivalent. Owner may, upon thirty (30) days written notice to Contractor, require Contractor to change any carrier whose rating drops below an "A-VII" rating. Eligible insurers include admitted insurers that have been issued a certificate of authority from the Oregon Department of Consumer and Business Services authorizing them to conduct an insurance business and issue policies of insurance in the state of Oregon, and certain non-admitted surplus lines insurers that satisfy the requirements of applicable Oregon law and which are subject to approval the Owner.

G.3.1.3 Additional Insured. Each liability policy, except Workers' Compensation and Professional Liability, shall be endorsed to include Owner, its officers, trustees, employees and agents as additional insured but only with respect to the Contractor's activities to be performed under this Contract

If Contractor cannot obtain an insurer to name the Owner as additional insured, Contractor shall obtain at Contractor's expense, and keep in effect during the term of this Contract, Owners and Contractors Protective Liability Insurance, naming the Owner as additional insured with minimum limits of \$2,000,000 per occurrence and \$2,000,000 aggregate. This policy must be kept in effect for 36 months following Final Completion. As evidence of coverage, Contractor shall furnish the actual policy to Owner prior to execution of the Contract.

G.3.1.4 Notice of Cancellation or Change. If the Contractor receives a non-renewal or cancellation notice from an insurance carrier affording coverage required herein, or receives notice that coverage no longer complies with the insurance requirements herein, Contractor agrees to notify Owner by fax within five (5) business days with a copy of the non-renewal or cancellation notice, or written specifics as to which coverage is no longer in compliance. When notified by Owner, the Contractor agrees to stop Work pursuant to this Contract, unless all required insurance remain in effect. Any failure to comply with the reporting provisions of this insurance, except for the potential exhaustion of aggregate limits, shall not affect the coverages provided to the Owner.

Owner shall have the right, but not the obligation, of prohibiting Contractor from entering the Work site until a new certificate(s) of insurance is provided to Owner evidencing the replacement coverage. The Contractor agrees Owner reserves

the right to withhold payment to Contractor until evidence of reinstated or replacement coverage is provided to Owner.

G.3.1.5 Deductibles and Self-insured Retentions. Any deductible, self-insured retention and/or self-insurance in excess of \$50,000 may be subject to approval by the Owner in writing.

G.3.2 Workers' Compensation. All employees, including Contractor, that employs subject workers who work under this Contract in the State of Oregon shall comply with ORS 656.017 and provide the required Worker's Compensation coverage, unless such employers are exempt under ORS 656.126. This shall include Employer's Liability Insurance with minimum limits of \$1,000,000 each accident; \$1,000,000 disease-each employee; and \$1,000,000 disease-policy limit. Contractors who perform the Work without the assistance or labor of any employee need not obtain such coverage if the Contractor certifies so in writing. Contractor shall ensure that each of its Subcontractors complies with these requirements. The Contractor shall require proof of such Workers' Compensation coverage by receiving and keeping on file a certificate of insurance from each Subcontractor or anyone else directly employed by either the Contractor or its Subcontractors.

G.3.3 Commercial General Liability. Contractor shall obtain, and keep in effect at Contractor's expense for the term of the Contract, Commercial General Liability Insurance covering bodily injury and property damage in the amount of \$2,000,000 per occurrence and \$4,000,000 aggregate. This insurance shall include personal injury liability, products and completed operations, and contractual liability coverage for the indemnities provided under this Contract (to the extent contractual liability coverage for the indemnity is available in the marketplace).

G.3.4 Automobile Liability. Contractor shall obtain, at Contractor's expense, and keep in effect during the term of this Contract, Automobile Liability Insurance with "symbol 1" coverage (owned, hired and non-owned vehicles). The coverage may be written in combination with the Commercial General Liability Insurance. Contractor shall provide proof of insurance showing minimum limits of \$2,000,000 combined single limit. Contractor and its Subcontractors shall be responsible for ensuring that all non-owned vehicles maintain adequate Automobile Liability insurance while on site.

G.3.5 Umbrella Liability. Contractor shall obtain, at Contractor's expense, and keep in effect during the term of this Contract, Umbrella liability Insurance over and above the Commercial General Liability, Automobile Liability and Employers' Liability insurance coverage with minimum limits of \$5,000,000 per occurrence and \$5,000,000 aggregate.

G.3.6 Owner may adjust the insurance amounts required in Section G.3.4, G.3.4, and G.3.5 through the issuance of Supplemental General Conditions and a Contract.

G.3.7 Professional Liability. (if required by issuance of Supplemental General Conditions) Contractor shall obtain, at Contractor's expense, Professional Liability/Errors & Omissions insurance covering damages caused by any negligent error, omission, or professional misconduct of the Contractor. The policy may be either a practice based policy or a policy pertaining to the specific Project. Professional Liability insurance shall have minimum limits of \$3,000,000 each claim and \$3,000,000 aggregate. Contractor shall require that each of its Major Consultants and subcontractors (including structural, civil, mechanical, plumbing, electrical engineering, survey, geotechnical and materials testing) secures and maintains Professional Liability/Errors & Omissions with limits not less than \$2,000,000 each claim and

\$2,000,000 aggregate. All other Consultants and subcontractors not listed above shall have limits not less than \$1,000,000 each claim and \$1,000,000 aggregate.

- G.3.7.1 Tail Coverage. If the Professional Liability is arranged on a "claims made" basis, tail coverage will be required at the completion of this Contract for a duration of 36 months or the maximum time period available in the marketplace if less than 36 months. Contractor shall furnish certificates of insurance showing tail coverage as described or continuous "claims made" liability coverage for 36 months following Final Completion. Continuous "claims made" coverage will be acceptable in lieu of tail coverage, provided its retroactive date is on or before the effective date of this Contract. Owner's receipt of the certificate of insurance and/or endorsement evidencing such coverage shall be a condition precedent to Owner's obligation to make final payment and to Owner's final acceptance of Work or services and related warranty (if any).
- G.3.8 Pollution Liability (if required by Owner through issuance of Supplemental General Conditions) Contractor shall obtain, at Contractor's expense, and keep in effect during the term of this Contract, Pollution liability Insurance in minimum amounts of \$3,000,000 per occurrence and \$3,000,000 aggregate, naming Owner as additional insured, as noted in the Additional Insured section.
- G.3.9 Builders' Risk Insurance – Completed Value Basis. Unless otherwise provided, the Contractor shall purchase and maintain, in a company or companies lawfully authorized to do business in the jurisdiction in which the Project is located, Builders' Risk Insurance in the amount of the initial Contract Sum, plus value of subsequent modifications, change orders, and cost of material supplied or installed by others, comprising total value of the entire Project at the site on a replacement cost basis without optional deductibles. The earthquake and flood insurance sublimits will be equal to the maximum probable loss.
- G.3.9.1 Policy must provide coverage from the time any covered property becomes the responsibility of the Contractor, and continue without interruption during construction, renovation, or installation, including any time during which the covered property is being transported to the construction installation site, or awaiting installation, whether on or off site.
- G.3.9.2 The Builders' Risk Insurance shall include the Owner, the Contractor, subcontractors and sub-tier contractors in the Project as named insureds on the policy, and shall include a waiver of subrogation provision in favor of all parties.
- G.3.9.3 The Builders' Risk Coverage shall be written on a Special Covered Cause of Loss form and shall include theft, vandalism, malicious mischief, collapse, false-work, temporary buildings, transit, debris removal including demolition, increased cost of construction, architect's fees and expenses, flood (including water damage), earthquake, and if applicable, all below and above ground structures, piping, foundations including underground water and sewer mains, piling including the ground on which the structure rests and excavation, backfilling, filling, and grading.
- G.3.9.4 The Builders' Risk shall include a Beneficial Occupancy Clause. The policy shall specifically permit occupancy of the building during construction. Contractor shall take reasonable steps to obtain consent of the insurance company and delete any provisions with regard to restrictions within any Occupancy Clauses within the Builder's Risk Policy.
- G.3.9.5 Equipment Breakdown Coverage (a.k.a. Boiler & Machinery) shall be included as required by the Contract Documents or by law, which shall specifically covers insured equipment during

installation and testing (including cold and hot testing).

- G.3.9.6 The Builders' Risk shall include loss of use due to delays in project completion caused by covered peril losses to the Project, including loss of income and rents and soft costs.
- G.3.9.7 The deductible shall not exceed \$50,000 for physical damage and shall be the responsibility of the Contractor. The deductible shall be paid by the Contractor if the Contractor is negligent. The earthquake and flood deductible shall not exceed 2 percent of each loss or \$50,000, whichever is greater.
- G.3.9.8 OSU shall be provided with a certificate of insurance, as well as a copy of the policy.
- G.3.9.19 The Contractor shall be responsible for the payment of premium, giving or receiving notice of cancellation; and requesting amendments to this policy and accepting amendments to this policy made by the company.
- G.3.9.10 OSU reserves the right to purchase the Builder's Risk insurance policy.
- G.3.10 Builder's Risk Installation Floater. For Work other than new construction, Contractor shall obtain and keep in effect during the term of this Contract, a Builder's Risk Installation Floater for coverage of the Contractor's labor, materials and equipment to be used for completion of the work performed under this Contract. The minimum amount of coverage to be carried shall be equal to the full amount of the Contract. The policy will include as loss payees Owner, the Contractor and its Subcontractors as their interests may appear. Owner may waive this requirement at their sole and absolute discretion.
- G.3.11 Certificate(s) of Insurance. As evidence of the insurance coverage required by this Contract, the Contractor shall furnish certificate(s) of insurance to the Owner prior to the execution of the Contract. The certificates(s) will specify all of the parties who are additional insured or loss payees for this Contract, and the applicable endorsements will be attached. Additional insured endorsements must include completed operations without restriction to contractual requirements.
- G.3.12 Subcontractors. Subject to and following the written approval of the Owner as outlined in B.11.3 as related to Subcontracts and Assignment, the Contractor shall require Subcontractors to have insurance as outlined in section G.3.1 through G.3.4; however, the policy limits may be reduced, but no case shall the policy limits be less than \$1,000,000.
- G.3.13 Retainer Contract Program: For the Retainer Contract Program the term "Contract" as used in this Section G in the phrases "keep in effect during the term of this Contract" and "prior to execution of the Contract" shall mean each Retainer Contract Supplement issued under the Retainer Contract.

SECTION H SCHEDULE OF WORK

H.1 CONTRACT PERIOD

- H.1.1 Time is of the essence. The Contractor shall at all times carry on the Work diligently, without delay and punctually fulfill all requirements herein. If required by the Contract Documents, Contractor shall commence Work on the site within fifteen (15) Days of Notice to Proceed, unless directed otherwise.
- H.1.2 Unless specifically extended by Supplement Amendment, all Work shall be complete by the date contained in the Contract Documents. The Owner shall have the right to accelerate the completion date of the Work, which may require the use of overtime. Such accelerated Work schedule shall be an

acceleration in performance of Work under Section D.1.2 (f) and shall be subject to the provisions of Section D.1.

- H.1.3 The Owner shall not waive any rights under the Contract by permitting the Contractor to continue or complete in whole or in part the Work after the date described in Section H.1.2 above.

H.2 SCHEDULE

- H.2.1 Contractor shall provide, by or before the pre-construction conference, a detailed Construction Schedule for review and acceptance by the Owner. The submitted Construction Schedule must illustrate Work by significant project components, significant labor trades, long lead items, broken down by building and/or floor where applicable. Each Construction Schedule item shall account for no greater than 5% of the monetary value of the project or 5% of the available time. Construction Schedules with activities of less than one day or valued at less than 1% of the Contract shall be considered too detailed and shall not be accepted. Construction Schedules lacking adequate detail, or unreasonably detailed, shall be rejected. Included within the Construction Schedule are the following: Notice to Proceed, Substantial Completion, and Final Completion. Contractor shall provide an updated, full Project Construction Schedule with each payment request. In addition, twice monthly, the Contractor shall provide an updated three-week forward-looking schedule. Acceptance of the Construction Schedule by the Owner does not constitute agreement by the Owner as to the Contractor's sequencing, means, methods, or durations. Any positive difference between the Contractor's scheduled completion and the contract completion date is float owned by the Project. Use of the float shall be negotiated. In no case shall the Contractor make a claim for delays if the Work is completed within the Contract time but after Contractor's scheduled completion.

H.3 PARTIAL OCCUPANCY OR USE

- H.3.1 The Owner may occupy or use any completed or partially completed portion of the Work at any stage, provided such occupancy or use is consented to by public authorities having jurisdiction over the Work. Such partial occupancy or use may commence whether or not the portion is substantially complete, provided the Owner and Contractor have reasonably accepted in writing the responsibilities assigned to each of them for payments, retainage, if any, security, insurance or self-insurance, maintenance, heat, utilities, and damage to the Work, and have agreed in writing concerning the period for correction of the Work and commencement of warranties required by the Contract Documents with respect to such portion of the Work. Approval by the Contractor to partial occupancy or use shall not be unreasonably withheld. Immediately prior to such partial occupancy or use, the Owner and Contractor shall jointly inspect the area to be occupied or portion of the Work to be used in order to determine and record the condition of the Work. Partial occupancy or use of a portion or portions of the Work shall not constitute acceptance of Work not complying with the requirements of the Contract Documents.

SECTION I CORRECTION OF WORK

I.1 CORRECTION OF WORK BEFORE FINAL PAYMENT

The Contractor warrants to the Owner that materials and equipment furnished under the Contract will be of good quality and new unless otherwise required or permitted by the Contract Documents, that the Work will be free from defects, and that the Work will conform to the requirements of the Contract Documents. Work failing to conform to these requirements shall be deemed defective. Contractor shall promptly remove from the premises and replace all defective

materials and equipment as determined by the Owner, whether incorporated in the Work or not. Removal and replacement shall be without loss or expense to the Owner, and Contractor shall bear the cost of repairing all Work destroyed or damaged by such removal or replacement. Contractor shall be allowed a period of no longer than thirty (30) Days after Substantial Completion for completion of defective (Punch List) work. At the end of the thirty-day period, or earlier if requested by the Contractor, Owner shall arrange for inspection of the Work by the Architect/Engineer. Should the work not be complete, and all corrections made, the costs for all subsequent re-inspections shall be borne by the Contractor. If Contractor fails to complete the Punch List work within the thirty (30) Day period, Owner may perform such work and Contractor shall reimburse Owner all costs of the same within ten (10) Days after demand without affecting Contractor's obligations.

I.2 WARRANTY WORK

- I.2.1 Neither the final certificate of payment nor any provision of the Contract Documents shall relieve the Contractor from responsibility for defective Work and, unless a longer period is specified, Contractor shall correct all defects that appear in the Work within a period of one year from the date of issuance of the written notice of Substantial Completion by the Owner except for latent defects which will be remedied by the Contractor at any time they become apparent. The Owner shall give Contractor notice of defects with reasonable promptness. The Contractor shall perform the warranty Work by correcting defects within twenty-four (24) hours of notification by Owner, unless otherwise specified in the Contract Documents. Should the Contractor fail to respond within the specified response time, the Owner may, at its option, complete the necessary repairs using another contractor or its own forces. If Owner completes the repairs using Owner's own forces, Contractor shall pay Owner at the rate of one and one-half (1½) times the standard hourly rate of Owner's forces, plus related overhead and any direct non-salary costs. If Owner completes the repairs using another contractor, Contractor shall pay Owner the amount of Owner's direct costs billed by the other contractor for the work, plus the direct salary costs and related overhead and direct non-salary expenses of Owner's forces who are required to monitor that contractor's work. Work performed by Owner using Owner's own forces or those of another contractor shall not affect the Contractor's contractual duties under these provisions, including warranty provisions. In the event of warranty work consisting of emergency repairs, Owner may perform such work and Contractor shall reimburse Owner all costs of the same within ten (10) Days after demand, without affecting Contractor's obligations.
- I.2.2 Nothing in this Section I.2 provision shall negate guarantees or warranties for periods longer than one year including without limitation such guarantees or warranties required by other sections of the Contract Documents for specific installations, materials, processes, equipment or fixtures.
- I.2.3 In addition to Contractor's warranty, manufacturer's warranties shall pass to the Owner and shall not take effect until such portion of the Work covered by the applicable warranty has been accepted in writing by the Owner.
- I.2.4 The one-year period for correction of Work shall be extended with respect to portions of Work performed after Substantial Completion by the period of time between Substantial Completion and the actual performance of the Work, and shall be extended by corrective Work performed by the Contractor pursuant to this Section, as to the Work corrected. The Contractor shall remove from the site portions of the Work which are not in accordance with the requirements of the Contract Documents and are neither corrected by the Contractor nor accepted by the Owner.

- I.2.5 Nothing contained in this Section I.2 shall be construed to establish a period of limitation with respect to other obligations which the Contractor might have under the Contract Documents. Establishment of the period for correction of Work as described in this Section I.2 relates only to the specific obligation of the Contractor to correct the Work, and has no relationship to the time within which the obligation to comply with the Contract Documents may be sought to be enforced, nor to the time within which proceedings may be commenced to establish the Contractor's liability with respect to the Contractor's obligations other than specifically to correct the Work.
- I.2.6 If the Owner prefers to accept Work which is not in accordance with the requirements of the Contract Documents, the Owner may do so instead of requiring its removal and correction, in which case the Contract Price will be reduced as appropriate and equitable. Such adjustment shall be effected whether or not final payment has been made.

**SECTION J
SUSPENSION AND/OR TERMINATION OF THE WORK**

J.1 OWNER'S RIGHT TO SUSPEND THE WORK

- J.1.1 The Owner has the authority to suspend portions or all of the Work due to the following causes:
- (a) Failure of the Contractor to correct unsafe conditions;
 - (b) Failure of the Contractor to carry out any provision of the Contract;
 - (c) Failure of the Contractor to carry out orders;
 - (d) Conditions, in the opinion of the Owner, which are unsuitable for performing the Work;
 - (e) Time required to investigate differing site conditions;
 - (f) Any reason considered to be in the public interest.
- J.1.2 The Owner shall notify Contractor and the Contractor's Surety in writing of the effective date and time of the suspension, and Owner shall notify Contractor and Contractor's surety in writing to resume Work.

J.2 CONTRACTOR'S RESPONSIBILITIES

- J.2.1 During the period of the suspension, Contractor is responsible to continue maintenance at the project just as if the Work were in progress. This includes, but is not limited to, protection of completed Work, maintenance of access, protection of stored materials, temporary facilities, and clean-up.
- J.2.2 When the Work is recommenced after the suspension, the Contractor shall replace or renew any Work damaged during the suspension, remove any materials or facilities used as part of temporary maintenance, and complete the project in every respect as though its prosecution had been continuous and without suspension.

J.3 COMPENSATION FOR SUSPENSION

- J.3.1 Depending on the reason for suspension of the Work, the Contractor or the Owner may be due compensation by the other party. If the suspension was required due to acts or omissions of Contractor, the Owner may assess the Contractor actual costs of the suspension in terms of administration, remedial work by the Owner's forces or another contractor to correct the problem associated with the suspension, rent of temporary facilities, and other actual costs related to the suspension. If the suspension was caused by acts or omissions of the Owner, the Contractor

may be due compensation which shall be defined using Section D, Changes in Work. If the suspension was required through no fault of the Contractor or the Owner, neither party shall owe the other for the impact.

J.4 OWNER'S RIGHT TO TERMINATE CONTRACT

- J.4.1 The Owner may, without prejudice to any other right or remedy, and after giving Contractor seven (7) Days' written notice and an opportunity to cure, terminate the Contract in whole or in part under the following conditions:
- (a) If Contractor should, voluntarily or involuntarily, seek protection under the United States Bankruptcy Code and Contractor as debtor-in-possession or the Trustee for the estate fails to assume the Contract within a reasonable time;
 - (b) If Contractor should make a general assignment for the benefit of Contractor's creditors;
 - (c) If a receiver should be appointed on account of Contractor's insolvency;
 - (d) If Contractor should repeatedly refuse or fail to supply an adequate number of skilled workers or proper materials to carry on the Work as required by the Contract Documents, or otherwise fail to perform the Work in a timely manner;
 - (e) If Contractor should repeatedly fail to make prompt payment to Subcontractors or for material or labor, or should disregard laws, ordinances or the instructions of the Owner; or
 - (f) If Contractor is otherwise in breach of any part of the Contract.
 - (g) If Contractor is in violation of Applicable Laws, either in the conduct of its business or in its performance of the Work.

- J.4.2 At any time that any of the above occurs, Owner may exercise all rights and remedies available to Owner at law or in equity, and, in addition, Owner may take possession of the premises and of all materials and appliances and finish the Work by whatever method it may deem expedient. In such case, the Contractor shall not be entitled to receive further payment until the Work is completed. If the Owner's cost of finishing the Work exceeds the unpaid balance of the Contract Price, Contractor shall pay the difference to the Owner.

J.5 TERMINATION FOR CONVENIENCE

- J.5.1 Owner may terminate the Contract in whole or in part whenever Owner determines that termination of the Contract is in the best interest of Owner or the public.
- J.5.2 The Owner shall provide the Contractor with seven (7) Days prior written notice of a termination for Owner's or for public convenience. After such notice, the Contractor shall provide the Owner with immediate and peaceful possession of the premises and materials located on and off the premises for which the Contractor received progress payment under Section E. Compensation for Work terminated by the Owner under this provision will be according to Section E. In no circumstance shall Contractor be entitled to lost profits for Work not performed due to termination.

J.6 ACTION UPON TERMINATION

- J.6.1 Upon receiving a notice of termination, and except as directed otherwise by the Owner, Contractor shall immediately cease

placing further subcontracts or orders for materials, services, or facilities. In addition, Contractor shall terminate all subcontracts or orders to the extent they relate to the Work terminated and, with the prior written approval of the Owner, settle all outstanding liabilities and termination settlement proposals arising from the termination of subcontracts and orders.

J.6.2 As directed by the Owner, Contractor shall, upon termination, transfer title and deliver to the Owner all Record Documents, information, and other property that, if the Contract had been completed, would have been required to be furnished to the Owner.

J.6.3 Upon Owner's notice of termination pursuant to either Section J.4 or J.5, if Owner shall so elect, Contractor shall assign the Owner such subcontracts and orders as Owner shall specify. In the event Owner elects to take assignment of any such subcontract or order, Contractor shall take such action and shall execute such documents as Owner shall reasonably require for the effectiveness of such assignment and Contractor shall ensure that no contractual arrangement between it and its subcontractors or suppliers of any tier or sub-tier shall prevent such assignment.

SECTION K CONTRACT CLOSE OUT

K.1 RECORD DOCUMENTS

As a condition of final payment (refer also to section E.6), Contractor shall comply with the following: Contractor shall provide Record Documents for the entire project to Owner. Record Documents shall depict the project as constructed and shall reflect each and every change, modification, and deletion made during the construction. Record Documents are part of the Work and shall be provided prior to the Owner's issuance of final payment. Record Documents include all modifications to the Contract Documents unless otherwise directed, and accurate MWESB Reports.

K.2 OPERATION AND MAINTENANCE MANUALS

As part of the Work, Contractor shall submit two completed operation and maintenance manuals ("O & M Manuals") for review by the Owner prior to submission of any pay request for more than 75% of the Work. Owner's receipt of the O & M Manuals shall be a condition precedent to any payment thereafter due. The O & M Manuals shall contain a complete set of all Submittals, all product data as required by the specifications, training information, telephone list and contact information for all consultants, manufacturers, installer and suppliers, manufacturer's printed data, record and shop drawings, schematic diagrams of systems, appropriate equipment indices, warranties and bonds. The Owner shall review and return one O & M Manual for any modifications or adjustments required. Prior to submission of its final pay request, Contractor shall deliver two (2) complete and approved sets of O & M Manuals in paper form and one (1) complete and approved set in electronic form to the Owner and Owner's receipt of the O & M Manuals shall be a condition precedent to Owner's obligation to make final payment.

K.3 COMPLETION NOTICES

K.3.1 Contractor shall provide Owner written notice of both Substantial and Final Completion. The certificate of Substantial Completion shall state the date of Substantial Completion, the responsibilities of the Owner and Contractor for security, maintenance, heat, utilities, damage to the Work and insurance, and the time within which the Contractor shall finish all items on the Punch List accompanying the Certificate. Both completion notices must be signed by the Contractor and the Owner to be valid. The Owner shall provide the final signature on the notices. The notices shall take effect on the date they are signed by the Owner.

K.3.2 Substantial Completion of a facility with operating systems (e.g., mechanical, electrical, HVAC) shall be that degree of completion that has provided a minimum of thirty (30) continuous Days of successful, trouble-free operation, which period shall begin after all performance and acceptance testing has been successfully demonstrated to the Owner. All equipment contained in the Work, plus all other components necessary to enable the Owner to operate the facility in the manner that was intended, shall be complete on the Substantial Completion date. The Contractor may request that a Punch List be prepared by the Owner with submission of the request for the Substantial Completion notice.

K.4 TRAINING

As part of the Work, and prior to submission of the final application for payment, the Contractor shall schedule with the Owner training sessions for all equipment and systems as required by the Contract Documents. Contractor shall schedule training sessions at least two weeks in advance of the date of training to allow Owner to provide its personnel with adequate notice. The O & M Manual shall be used as a basis for training. In addition to any off-site training required by the Contract Documents, training shall include a formal session conducted at the Work site after the equipment and/or system is completely installed and operational in its normal operating environment.

K.5 EXTRA MATERIALS

As part of the Work, Contractor shall provide spare parts, extra maintenance materials, and other materials or products in the quantities specified in the Contract Documents prior to final payment. Delivery point for extra materials shall be designated by the Owner.

K.6 ENVIRONMENTAL CLEAN-UP

As part of the Final Completion notice, or as a separate written notice submitted with or before the notice of Final Completion, the Contractor shall notify the Owner that all environmental and pollution clean-up, remediation and closure have been completed in accordance with all Applicable Laws and pursuant to the authority of all agencies having jurisdiction, and Contractor shall provide Owner with any and all documentation related to the same, including but not limited to directives, orders, letters, certificates and permits related to or arising from such environmental pollution. The notice shall reaffirm the indemnification given under Section F.5.1 above. Contractor's completion of its obligations under this Section K.6 and Owner's receipt of documents evidencing such completion shall be a condition precedent to Owner's obligation to make final payment.

K.7 CERTIFICATE OF OCCUPANCY

Owner's receipt of an unconditioned certificate of occupancy from the appropriate state and/or local building officials shall be a condition precedent to Owner's obligation to make final payment, except to the extent failure to obtain an unconditional certificate of occupancy is due to the sole fault or neglect of Owner.

K.8 OTHER CONTRACTOR RESPONSIBILITIES

The Contractor shall be responsible for returning to the Owner all property of Owner issued to Contractor during construction such as keys, security passes, site admittance badges, and all other pertinent items. Upon notice from Owner, Contractor shall be responsible for notifying the appropriate utility companies to transfer utility charges from the Contractor to the Owner. The utility transfer date shall not be before Substantial Completion and may not be until Final Completion, if the Owner does not take beneficial use of the facility and the Contractor's forces continue with the Work.

K.9 SURVIVAL

All warranty and indemnification provisions of this Contract, and all of Contractor's other obligations under this Contract that are not fully performed by the time of Final Completion or termination, shall survive Final Completion or any termination of the Contract.

As indicated in the General Conditions of your contract(s) Section E.2.9, OSU requires that we gather MWESB (Minority, Women's Emerging Small Business) Contractor/Subcontractor information. This is an Oregon State University requirement and the information will be gathered annually and at time of final payment.

- **You must do this step first or the report will not let you add any information:** In Row 1 Column B there is a drop down menu. You must select yearend (if the job has not been completed) or final (if the job is completed and you have submitted for retention). Once you choose yearend or final in the drop down menu there will be areas highlighted in light green and red. Those are the areas that you are required to fill out. If you did not use or planning to use any MWESB then the left side of the report (Light Green area) still needs to be filled out and the red area needs to remain blank.
- If your agency is an MWESB or if you are using/used an MWESB subcontractor then you need to fill out the information in the report that is highlighted in light green and red (see instructions in the next bullet). If you are not an MWESB or used a Subcontractor that is an MWESB then you need to fill out the left side of the form (Light Green areas) and leave the red area blank.
- In row 2 Column B there is another drop down menu, click the drop down menu and choose Fiscal Year 2015.
- In Row 4 Column B there is another drop down menu, click there and choose OSU.

In compliance with Oregon Prevailing Wage Law, the following is incorporated into this Invitation to Bid:

The Contractor and all subcontractors shall comply with the provisions of ORS 279C.800 through 279C.870, relative to Prevailing Wage Rates as outlined in Sections C.1 and C.2 of the General Conditions. This Purchase Order is subject to the following BOLI wage rate requirements, which are incorporated herein by reference:

- January 1, 2019 PWR Apprenticeship Rates
- January 1, 2019 Prevailing Wage Rates for Public Works Contracts in Oregon
- July 1, 2018 Definitions of Covered Occupations for Public Works Contracts in Oregon

These BOLI wage rates are available on line at:
http://www.boli.state.or.us/BOLI/WHD/PWR/pwr_state.shtml

SECTION 01 11 00

SUMMARY OF WORK

PART 1 GENERAL

1.01 SUMMARY OF WORK

- A. The Work consists of the following:

Contractor to install One (1) owner-furnished contractor-installed (OFCI) air-cooled chiller and associated piping and appurtenances at the Dixon Recreation Center as shown in the Contract Drawings. Scope includes removal of existing roof-mounted chiller. Work includes provision of chilled water pumps, buffer tanks, and associated piping, as well as some demolition work and controls modifications to provide a functioning HVAC system for the building.

Significant coordination will be required for placement and set up of the new OFCI chiller unit, and the switch over from the current temporary chiller located in the loading dock. OFCI chiller unit will be located at OSU Facilities Services shop yard off of SW Benton Place. Contractor will be responsible for moving OFCI chiller unit from this location to the project site.

Coordination will also be required for work inside the facility during hours of operation, to minimize disruption to occupants.

- B. Work shall be started within ten (10) calendar days after signing of Contract on behalf of Oregon State University. The Contract may not be signed prior to approval of the Contractor's Certificate of Insurance by Construction Contract Administration (CCA), Oregon State University. Work shall be completed within Seventy-Five (75) calendar days.

1.02 CONTRACTORS USE OF PREMISES

- A. Contractor shall limit use of the Premises for work and storage to allow for:
1. Owner occupancy, day and night.
 2. Public use, day and night.
 3. Security.
 4. Safe entry and exit for vehicles and pedestrians.
 5. Fire egress.
- B. Coordinate all operations with the Owner's Authorized Representative during the construction period. A 96 hour notification is required prior to scheduled utility shutdowns or street closures, but more lead time is often required to schedule around other critical activities.
- C. Limit Contractor's employee parking to locations designated at the Pre-construction Conference.

1.03 OWNER OCCUPANCY

- A. The Owner will occupy the Premises during the entire period of construction for the conduct of normal operations. Cooperate with Owner's Authorized Representative in construction operations to minimize conflict and to facilitate the Owner's usage especially in the following areas:
 - 1. Restricted access and parking.
 - 2. Use of stairs.
 - 3. Storage space availability.
- B. Conduct operations in such a way to ensure the least inconvenience to the general public, including:
 - 1. Limitations and easements.
 - 2. Emergency vehicle access.
 - 3. Building access to the public, day and night.

1.04 ASBESTOS AND OTHER HAZARDOUS MATERIAL

- A. The Owner has made a reasonable attempt to locate and identify asbestos or other hazardous material that may be encountered during the course of the Work.
- B. If the Contractor observes or suspects the existence of asbestos, polychlorinated biphenyl (PCB) or other hazardous materials in the structure or components of the building, the Contractor shall immediately stop work and notify the Owner's Authorized Representative.
- C. The Owner will arrange for the removal of asbestos, polychlorinated biphenyl (PCB) or other hazardous materials as required by Facilities Services personnel or by separate contract.
- D. Schedule ten (10) days of slack or "down" time for the removal of hazardous materials without penalty to Owner for the delay of the Contract.

1.05 LEAD BASED PAINT

- A. The Owner may have tested existing paint in the project area and if levels are found the following conditions apply.
- B. Contractor shall remove paint as specified for surface preparation and capture removed material for disposal.
- C. Contractor shall follow OSHA guidelines involving exposure to workers.
- D. Owner will provide containers for Contractor's use at project site.
- E. Contractor shall comply with the requirements of DEQ and EPA and shall submit a lead abatement plan.
- F. Contractor shall separate lead contaminated material from effluent and water.
- G. Owner will dispose of lead paint and effluent resulting from stripping operation.

H. Soil contaminated by stripping operations shall be replaced with topsoil.

END OF SECTION

SECTION 01 24 76

APPLICATIONS FOR PAYMENT

PART 1 GENERAL

1.01 SECTION INCLUDES

- A. Work of this Section includes forms and procedures for progress payments.
- B. Related work specified elsewhere.
 - 1. For the primary discussion of payments, refer to OSU General Conditions, Section E, as supplemented.
 - 2. In compliance with OSU General Conditions, Section K, no payments beyond 75% will be made by the Owner before two complete copies of the draft Operation and Maintenance Manuals have been received for review by the Owner.

1.02 APPLICATION FORMS

- A. For applications for payment, use sample contract payment request on company letterhead, or AIA Document G702, supported by AIA Document G703, Continuation Sheet, or similar document.
- B. Prepare the Schedule of Values in such a manner that each major item of Work and each subcontracted item of Work is shown as a line item broken down in terms of material and labor costs on AIA Document G703, Application Certification of Payment, Continuation Sheet or similar format. The sample continuation sheet shall be the minimum Schedule of Values breakdown.
- C. The Schedule of Values shall be submitted for review by the Owner prior to the first application for payment; and may be used when, and only when, accepted in writing by the Owner.
- D. Payment request is to include the Contractor's Federal Tax Identification number and return address.

1.03 PAYMENTS

- A. The Owner will make progress payments on account of the Contract once monthly for the scheduled duration of the project (i.e. three (3) payments on a three-month project), based on the value of work accomplished or materials on the job site, as stated in the Schedule of Values on the Application and Certificate Payment.
- B. Notwithstanding the foregoing, as this project is scheduled to take three (3) month to complete, Owner will only make three (3) payments, plus a final retainage payment, as applicable.
- C. Complete and forward Application to the Owner on or about the 15th day of each month for work performed the previous month and include certified payroll

statements as specified in the OSU General Conditions.

- D. Submit one (1) copy of forms requesting payment to the Owner.
- E. Payments will be made on protected materials on hand at the job site properly stored, protected, and insured.
- F. Estimated quantities shall be subject to the Owner's review and judgment.

1.04 EARLY PURCHASE AND PAYMENT OF MATERIALS AND EQUIPMENT

- A. Order materials and equipment requiring a long lead or waiting time early so as not to delay progress of the Work.
- B. The Contractor will be reimbursed for early order materials or equipment upon receipt and verification of quality and quantity against submittals and shipping documents by the Owner's Authorized Representative.
- C. Receipt shall be to the job site or stored at Owner's other premises in an orderly and safe manner, secured from normal weather damage.
- D. Security remains the responsibility of the Contractor.

END OF SECTION

CONTRACT PAYMENT REQUEST

DATE: _____

TO: Administrative Services Accounting
Oregon State University
3015 SW Western Blvd
Corvallis, OR 97333

Payment Request No. _____ Contract No. _____ Period from _____ to _____

Project: _____

Original Contract Amount..... \$ _____

Change Orders (Net Amount) \$ _____

Contract Total to Date \$ _____

=====

Total Completed and Stored to Date \$ _____

Less Retainage (5%), if applicable..... \$ _____

Total Earned, Less Retainage (if applicable)..... \$ _____

Less Previous Payments \$ _____

Net Amount Due this Request \$ _____

The undersigned Contractor certifies that, to the best of his/her knowledge, information, and belief, the Work covered by this request has been completed in accordance with the Contract Documents, that all amounts have been paid for Work for which previous applications for Payment were issued and payments received from the Owner, and that the amount shown herein is now due.

Contractor: _____

By: _____ Date: _____

Federal Tax ID Number: _____

Address: _____

CONTINUATION SHEET

NOTES:

Amounts are stated to the nearest penny.
Use Column I on Contracts where variable retainage for line items may apply,
or if retainage is required.

Change Orders are usually listed as the last items of the basic schedule.

Project Name: _____

Application No.: _____

Date: _____

Period To: _____

WRN No.: _____

A	B	C	D	E	F	G		H	I
Item No.	Description of work	Scheduled Value	Work Completed		Materials Presently Stored (Not in D or E)	TOTAL Completed & Stored (D+E+F)	% Completed (G/C)	Balance to Finish (C-G)	Retainage
			From Previous Applications	This Period					
TOTALS									

SECTION 01 25 00

PRODUCT SUBSTITUTION PROCEDURES

PART 1 GENERAL

1.01 SECTION INCLUDES

- A. General requirements for the Work in relation to substitutions and product options.
- B. Submit to the Owner's property insurance carrier shop drawings, samples, and product data (such as manufacturer's standard schematic drawings and other literature) when required by individual Specifications sections.
- C. Related Work Specified Elsewhere
 - 1. Instructions to Bidders.
 - 2. OSU General Conditions.

1.02 REQUESTS FOR SUBSTITUTIONS

- A. Requests for substitution of products in place of those specified shall be in accordance with Instructions to Bidders, and as specified herein.

1.03 CONTRACTOR'S RESPONSIBILITIES

- A. Investigate proposed products and determine that they are equal or superior in all respects to products specified.
- B. Provide same guarantee for accepted substitutions as for products specified.
- C. Coordinate installation of accepted substitutions into the Work, making such changes as may be required for the Work to be complete in all respects.

1.04 SUBSTITUTIONS DURING BIDDING

- A. Submit two (2) copies of the following information with each request to the Owner:
 - 1. CSI substitution request form.
 - 2. Comparison of proposed substitution with product, material or system specified.
 - 3. Complete data, substantiating compliance of proposed substitution with the Contract Documents.
 - 4. Test numbers and supporting reports, indicating compliance with referenced standards.
 - 5. Evidence that warranty requirements are acceptable.
 - 6. Details indicating specific deviations proposed for the substitution.
 - 7. Reference and applicable Specification sections.
 - 8. Applicable product samples.
- B. All substitution requests shall be received in the Owner's office no less than ten (10) calendar days before bid opening. Requests received after this date will

not be considered.

1.05 SUBSTITUTIONS DURING CONSTRUCTION

- A. Substitutions will normally not be considered after date of Contract except when required due to unforeseen circumstances.
- B. Within a period of thirty (30) days after date of Contract, the Owner may, at its option, consider formal written requests for substitution of products in place of those specified, when submitted in accordance with the requirements stipulated herein.
- C. One or more of the following conditions must be documented in any such request:
 - 1. Required for compliance with final interpretation of code or insurance requirements.
 - 2. Required due to unavailability of a specified product.
 - 3. Required because of the inability of the specified product to perform properly or to fit in the designated space.
 - 4. Substitution would be substantially in the best interest of the Owner in terms of cost, time, or other considerations.

1.06 SUBSTITUTIONS NOT PERMITTED

- A. If implied on submittals without first requesting approval thereof.
- B. If acceptance will require substantial revision of the Contract Documents.

END OF SECTION

SUBSTITUTION REQUEST FORM

TO: _____

PROJECT: _____

SPECIFIED ITEM:

Section	Page	Paragraph	Description
---------	------	-----------	-------------

The undersigned requests consideration of the following:

PROPOSED SUBSTITUTION: _____

Attached data includes product description, specifications, drawings, photographs, performance and test data adequate for evaluation of the request; applicable portions of the data are clearly identified.

Attached data also includes description of changes to Contract Documents which proposed substitution will require for its proper installation.

The undersigned states that the following paragraphs, unless modified on attachments, are correct:

1. The proposed substitution does not affect dimensions shown on Drawings.
2. The undersigned will pay for changes to the building design, including engineering design, detailing and construction costs caused by the requested substitution.
3. The proposed substitution will have no adverse effect on other trades, the construction schedule, or specified warranty requirements.
4. Maintenance and service parts will be locally available for the proposed substitution.

The undersigned further states that the function, appearance and quality of the Proposed Substitution are equivalent or superior to the Specified Item.

Submitted by:

Signature _____

Firm _____

Address _____

Date _____

Telephone _____

Attachments:

For use by Design Consultant:

Accepted Accepted as noted

Not Accepted Received too late

By _____

Date _____

Remarks _____

SECTION 01 31 19

PROJECT MEETINGS

PART 1 GENERAL

1.01 PRE-CONSTRUCTION MEETING

- A. Architect/Engineer/Designer, Contractor and Owner will meet prior to start of the Work (within seven (7) days after notice to proceed) to discuss at least the following topics and any others of mutual interest.
1. Schedule of Values
 2. Permit Status/tree protection/erosion control
 3. List of sub-contractors
 4. Job inspections.
 5. Early purchase of, and/or lead time requirements for material and equipment/repurchase of equipment
 6. Monthly payment date/SOP for pay requests
 7. Portion of site to be occupied by construction.
 8. Parking/Staging areas
 9. Non-smoking campus requirements
 10. Maintenance of access and safety.
 11. Processing of field decisions and change orders
 12. Labor provisions/labor rates for subs
 13. Material submittals/deferred submittals
 14. Owner access during construction.
 15. Review of Contract Documents/review ADA requirements/cross-slopes
 16. Coordination procedures and separate contracts.
 17. Progress schedules.
 18. Critical Work sequencing.
 19. Safety and emergency procedures/24 hour contact numbers
 20. Security procedures.
 21. Hazardous materials.
 22. Progress meetings.
 23. Contract close-out.
- B. Location of Meeting: Project site

1.02 PROGRESS MEETINGS

- A. The Contractor will schedule and administer progress meetings and will:
1. Prepare agendas.
 2. Schedule progress meetings, frequency, time and day to be determined during pre-construction meeting.
 3. Make physical arrangements for and preside at meetings.
 4. Record minutes and include decisions.
 5. Distribute copies of minutes to participants within four (4) days after meetings.

- B. Location of Meetings: Project site.
- C. Attendance:
 - 1. The Owner or Owner's Authorized Representative.
 - 2. Contractor.
 - 3. Subcontractors affected by agenda.
 - 4. Project Architect/Engineer/as necessary.
 - 5. Owner will attend meeting to ascertain Work is expedited consistent with progress schedule and with Contract Documents.
- D. Minimum Agenda:
 - 1. Review and approve minutes from previous meeting.
 - 2. Review Work progress since previous meeting.
 - 3. Discuss field observations, and problems.
 - 4. Review delivery schedules, construction schedule, and identify problems which impede planned progress.
 - 5. Review proposed changes.
 - 6. Material submittals.
 - 7. Note all new subcontractors performing Work at the job site.

END OF SECTION

SECTION 01 33 23

SHOP DRAWINGS, PRODUCT DATA, SAMPLES

PART 1 GENERAL

1.01 SECTION INCLUDES

- A. Submit to the Owner shop drawings, samples, and product data (such as manufacturer's standard schematic drawings and other literature) when required by individual Specifications sections.
- B. Related Work Specified Elsewhere
 - 1. Instructions to Bidders.
 - 2. OSU General Conditions.

1.02 SUBMITTAL SCHEDULING

- A. For items requiring review by the Owner only, submittals shall be sent to the Owner at least 15 calendar days before the date each is required for fabrication or installation.
- B. Submittals to be reviewed by Owner's consultants shall be sent to the Owner at least 20 calendar days before the date each is required for fabrication or installation.
- C. Submittals to be reviewed by Owner's property insurance carrier shall be sent to Owner as directed in individual specification sections.
- D. Submittals involving Substitution requests or other modifications requiring review by the Owner and/or the Owner's consultants shall be sent to the Owner at least 20 calendar days before the date each is required for fabrication or installation.

1.03 SUBMITTAL CONTENT AND FORMAT

- A. General Requirements:
 - 1. Shop Drawings: Submit in electronic format and, if requested by Owner's Authorized Representative, submit one reproducible transparency and 1 print of each drawing.
 - 2. Product Data: Submit electronically, and if requested by Owner's Authorized Representative, up to 6 hard copies.
 - 3. Samples: Submit the number and type stated in each Specification Section. Submit a minimum of three sets of color samples where color selection is required.
 - 4. Submittals shall include:
 - a. Date and revision dates return date requested.
 - b. Project title and number.
 - c. The names of the Contractor, subcontractor, supplier, and manufacturer.
 - d. Identification of product or material, with Specification Section number.

- e. Relation to adjacent critical features of work or materials.
 - f. Field dimensions, clearly identified as such.
 - g. Applicable standards, such as ASTM number or Federal Specification.
 - h. Identification of deviations from Contract Documents, and for products accompanied by Substitution request as required by Section 01 25 00.
 - i. Contractor's stamp legibly signed, essentially as follows:
 - 1) The undersigned, acting on behalf of the Contractor, certifies that this submittal has been reviewed and is approved; products have been verified as being as specified, field measurements and field construction criteria have been or will be coordinated, and the submittal is in compliance with Contract Documents.
5. Re-submission Requirements:
- a. Revise initial drawings as required and resubmit as specified for initial submittal.
 - b. Indicate on drawings any changes which have been made other than those requested by the Owner or the owner's consultants.
6. The Owner may return without review any submittal not meeting the requirements listed above.
- B. Shop Drawings:
1. Present data in a clear and thorough manner.
 2. Details shall be identified by reference to sheet and detail, schedule or room numbers shown on Contract Documents.
 3. Structural items shall be identified by location in the completed structure. Identify details by reference to contract sheet and detail numbers.
 4. Minimum sheet Size: 8 ½ x 11".
- C. Product Data:
1. Manufacturer's catalog sheets, brochures, diagrams, schedules, performance charts, illustrations and other standard descriptive data:
 - a. Clearly mark each copy to identify pertinent product or models.
 - b. Show dimensions, weights, and clearances required.
 - c. Show performance data consisting of capabilities, ROM, KW, pressure drops, design characteristics and consumption; conforming as closely as possible to the test methods referenced in the Plans and Specifications.
 - d. Show wiring or piping diagrams and controls.
 2. Manufacturer's standard schematic drawings and diagrams:
 - a. Modify to delete information which is not applicable.
 - b. Supplement standard information to provide information specifically applicable to the Work.
- D. Samples:
1. Insure that samples are of sufficient size to indicate the general visual effect or color.
 2. Where samples must show a range of color, texture, finish, graining, or

- other property, submit sets of pairs illustrating the full scope of this range.
3. One (1) sample or one (1) set of approved samples will be retained by the Owner; final work will be measured against approved samples.

1.04 QUALITY ASSURANCE

- A. Process submittals in ample time for review, as applicable, so as to not delay the Work. All submittals shall be received by the Owner within ten (10) days after pre-construction.

1.05 DEFINITIONS

- A. The Owner will mark reviewed materials as follows:
 1. "No Exception Taken," which means fabrication, manufacture and/or installation may proceed.
 2. "Make Revisions Noted," which means fabrication, manufacture and/or installation may proceed with revisions as noted.
 3. "Revise and Resubmit," which means that fabrication, manufacture and/or installation may not proceed.
 4. "Rejected," which means do not proceed; make arrangements for the review of the proposed Work with the Owner as soon as possible.

1.06 PROCESSING

- A. Review submittals, make necessary corrections, and become familiar with the content of the submittals.
- B. Mark each item with Contractor's stamp.
- C. Accompany submittals with a transmittal letter bearing the project name, Contractor's name, number of items, and other pertinent data.
- D. Keep one copy of each reviewed submittal on the job site at all times.
- E. Be responsible for obtaining and distributing prints of shop drawings to the various suppliers, and the Owner once review process has been completed. Make prints of reviewed shop drawings only from transparencies which carry the appropriate stamp and endorsement.

END OF SECTION

SECTION 01 42 13**ABBREVIATIONS AND SYMBOLS****PART 1 GENERAL****1.01 REQUIREMENTS INCLUDED**

- A. Words which may be found elsewhere in the Project Manual and Drawings are abbreviated in accordance with the standards set forth in the following table:

A/C	air conditioning	CEM	cement
AB	anchor bolt	CF	cubic foot
AC	asphaltic concrete	CFOI	contractor furnished owner installed
ACT	acoustical tile	CG	corner guard
AD	area drain	CH	ceiling height
ADD	addendum	CI	cast iron
ADD'L	additional	CJ	control joint
ADH	adhesive	CKBD	chalkboard
AFF	above finish floor	CL	centerline
AGG	aggregate	CLG	ceiling
AL	aluminum	CLR	clear(ance)
ALLOW	allowable	CM	construction manager
ALT	alternate	CMT	ceramic mosaic (tile)
ANOD	anodized	CMU	concrete masonry unit
AP	access panel	COL	column
APPRX	approximate	COM	communications
ARCH	architect(ural)	CONC	concrete
ASPH	asphalt	CONN	connect(ion)
AUTO	automatic	CONST	construction
AVE	avenue	CONT	continuous or continue
		CONTR	contract(or)
BD	board	CPT	carpet
BIT	bituminous	CRS	course(s)
BLDG	building	CS	countersink
BLKG	blocking	CSMT	casement
BM	bench mark, beam(s)	CT	ceramic tile
BOT	bottom	CTR	center
BRZ	bronze	CVG	clear vertical grain
BS	both side	CW	cold water
		CWT	ceramic wall tile
CB	catch basin	CY	cubic yard

D	depth	FA	fire alarm
DEMO	demolish, demolition	FAF	fluid applied flooring
DEP	depressed	FARF	fluid applied resilient floor
DF	drinking fountain	FAS	fasten, fastener
DIA	diameter	FBD	fiberboard
DIAG	diagonal	FBT	finished blowing temperature
DIM	dimension	FD	floor drain, fire damper
DISP	dispenser	FE	fire extinguisher
DIV	division	FEC	fire extinguisher cabinet
DL	dead load	FF	factory finish
DMT	demountable	FGL	fiberglass
DN	down	FHMS	flathead machine screw
DP	dampproofing	FHWS	flathead wood screw
DR	door	FIN	finish(ed)
DS	downspout	FLCO	floor cleanout
DT	drain tile	FLR	floor(ing)
DTL	detail	FLUR	fluorescent
DW	dumbwaiter	FND	foundation
DWG	drawing(s)	FOC	face of concrete
DWR	drawer	FOIC	furnished by owner/installed by contractor
EA	each	FOIO	furnished by owner/installed by owner
EB	expansion bolt	FOM	face of masonry
EF	each face	FP	fireproofing, flash point
EJ	expansion joint	FPHB	freeze-proof hose bib
EL	elevation	FR	fire resistive, fire rated
ELEC	electric(al)	FRM	frame(d), (ing)
EMBED	embedment	FS	full size
EMER	emergency	FSS	finished structural slab
ENCL	enclose(ure)	FT	foot
EP	electrical panel board	FTG	footing
EQ	equal	FTS	finished topping slab
EQUIP	equipment	GA	gage, gauge
EST	estimate	GALV	galvanized
EVT	equiviscious temperature	GB	grab bar or gypsum board
EW	each way	GC	general contractor
EWC	electric water cooler	GI	galvanized iron
EX.EXIT	existing	GL	glass, glazing
EXH	exhaust	GLS	glass resin wall surfacing
EXP	exposed	GP	gypsum
EXT	exterior		

HB	hose bib	LW	lightweight
HBD	hardboard	MAX	maximum
HC	hollow core	MB	machine bolt
HD	heavy duty	M. MECH	mechanic(al)
HDR	header	MFR	manufacture(r)
HDW	hardware	MH	manhole
HM	hollow metal	Min	minimum, minute
HOR	horizontal	MISC	miscellaneous
HP	high point	MO	masonry opening
HR	hour	MO#	model number
HT	height	MOD	modular
HTG	heating	MPH	miles per hour
HVAC	heating, ventilating, air conditioning	MS	machine screw
HWD	hardwood	MTL	metal
HWH	hot water heater	MULL	mullion
ID	inside diameter, identification	MWP	membrane waterproofing
IN	inch	NAT	natural, natural finish
INCIN	incinerator	NIC	not in contract
INCL	include(d), ion)	NO	number
INT	interior	NOM	nominal
INV	invert	NTS	not to scale
JB	junction box	OA	overall
JC	janitor's closet	OBS	obscure
JT	joint	OC	on center(s)
KD	kiln dried	OD	outside diameter
KCP	Keene's cement plaster	OF	overflow
KO	knockout	OFCI	owner furnished contractor installed
KP	kick plate	OFOI	owner furnished owner installed
LAB	laboratory	OHMS	ovalhead machine screw
LAM	lamine(d)	OHWS	ovalhead wood screw
LAV	lavatory	OPG	opening
LBS	pounds	OPP	opposite
LH	left hand	OZ	ounce(s)
LL	live load	P	paint(ed)
LONGIT	longitudinal	PB	push button
LP	low point	PCF	pounds per cubic foot
		PCP	putting coat plaster

PERF	perforate(d)	SQ	square
PL	plate, property line	SS	storm sewer
PLAM	plastic laminate	S4S	finished 4 sides
PLAS	plaster	SD	storm drain
PNL	panel	ST	steel, street
PP	push plate	ST ST	stainless steel
PR	pair	STD	standard
PREP	prepare	STR	structural
PSF	pounds per square foot	SUPP	supplement
PSI	pounds per square inch	SUPT	support
PT	point, pressure treated	SUSP	suspended
PTN	partition	SV	sheet vinyl
PVC	polyvinyl chloride		
PWD	plywood	T	tread
		TBM	top bench mark
QT	quarry tile	T&G	tongue and groove
		TB	towel bar
R	rise	TC	top of curb
RA	return air	TEL	telephone
RAD	radius	TEMP	tempered
RCP	reflected ceiling plan	THK	thickness
RD	roof drain	TKBD	tackboard
REF	reference	TO	top of
REFR	refrigerator	TP	top of paving
REINF	reinforce(ing)	TRANS	transverse
REQ	required	TS	top of slab
RET'G	retaining	TV	television
REV	revision(s), revised	TW	top of wall
RH	right had	TYP	typical
RM	room		
RO	rough opening	UNO	unless noted otherwise
RSF	resilient sheet flooring		
		VAT	vinyl asbestos tile
SC	solid core	VB	vapor barrier
SCHED	schedule	VCT	Vinyl Composition Tile
SEC	section	VERT	vertical
SF	square feet (foot)	VG	vertical grain
SHT	sheet	VIF	verify in field
SHTHG	sheathing	VWC	vinyl wall covering
SIM	similar		
SL	sleeve	W	width, wide, water
SOG	slab on grade	W/	with
SPEC	specification(s)	W/O	without

ABBREVIATIONS AND SYMBOLS
01 42 13 - 5

WC water closet
WD wood, wood finish
WP waterproof(ing)
WNS wainscot
WR water resistant

WS waterstop
WW window wall
WWC wood wall covering
WWF woven wire fabric

B. Words which may be found elsewhere in the Project Manual and Drawings are abbreviated in accordance with the standards set forth in the following table:

&	and
λ	angle
@	at
\varnothing	diameter, round
"	inches
:	is, shall b
'	feet
ζ	perpendicular
/	per
%	percent
#	pound, number
X	by (as in 2 by 4)

END OF SECTION

SECTION 01 42 16

DEFINITIONS

PART 1 GENERAL

1.01 SECTION INCLUDES

- A. Words which may be found elsewhere in the Contract Documents are defined in accordance with the standards set forth in the following table:

Approve:

Where used in conjunction with Architect's response to submittals, requests, applications, inquiries, reports and claims by Contractor, the meaning of term "approved" will be limited to the Architect's responsibilities and duties as specified in General and Supplementary Conditions. In no case will "approval" by Architect be interpreted as a release of Contract requirements.

As Detailed, As Shown:

Where "as detailed", "as shown" or words of similar importance are used, it shall be understood that reference to the Drawings accompanying the Specifications is made unless otherwise stated.

As Directed, As Required, As Authorized, As Reviewed, As Accepted:

Where "as directed", "as required", "as authorized", "as reviewed", "as accepted" or words of similar importance are used, it shall be understood that the direction, requirement, permission, authorization, review, or acceptance of the Architect is intended, unless otherwise stated.

As Indicated:

Where "as indicated" is used it shall be understood that reference to Drawings and/or Specifications is made unless otherwise stated.

Directed, Requested, etc.:

Terms such as "directed," "requested," "authorized," "selected," will be understood as "directed by Architect," "requested by Architect," and similar phrases shall not be interpreted to extend Architect's responsibility into Contractor's responsibility for construction supervision.

Furnish:

Except as otherwise defined in greater detail the term "furnish" is used to mean supply and deliver to project site, ready for unloading, unpacking, assembly, installation, etc., as applicable in each instance.

Indicated:

The term "indicated" is a cross-reference to graphic representations, notes or

schedules on drawings, to other paragraphs or schedules in the specifications and to similar means of recording requirements in Contract Documents. Where terms such as "shown," "noted," "scheduled," and "specified" are used in lieu of "indicated," it is for purpose of helping reader locate cross-reference and no limitation of location is intended except as specifically noted.

Install:

Except as otherwise defined in greater detail, the term "install" is used to describe operations at project site including unloading, unpacking, assembly, erection, placing, anchoring, applying, working to dimension, finishing, curing, protecting, cleaning and similar operations, as applicable in each instance.

Installer:

The term "installer" is defined as the entity (person or firm) engaged by Contractor, or its subcontractor or sub-subcontractor for performance of a particular unit of Work at project site, including installation, erection, application and similar required operations. It is a general requirement that such entities (Installers) be expert in operations they are engaged to perform.

Provide:

Except as otherwise defined in greater detail, term "provide" means furnish and install, complete and ready for intended use, as applicable in each instance.

END OF SECTION

SECTION 01 42 19

REFERENCE STANDARDS

PART 1 GENERAL

1.01 SECTION INCLUDES

- A. Quality Assurance.
- B. Location of References.
- C. Schedule of References.

1.02 QUALITY ASSURANCE

- A. For products or quality of work specified by association, trade, or federal standards, comply with requirements of the standard, except when more rigid requirements are specified or are required by applicable codes.
- B. Conform to reference standard by date of issue current on date of Contract Documents.
- C. General Applicability of Standards: Except where Contract Documents include more stringent requirements, applicable standards of the construction industry have the same force and effect as if bound or copied directly into Contract Documents.
- D. Such standards are made a part of the Contract Documents by reference.
- E. Individual sections indicate which codes and standards the Contractor must keep at the project site, available for reference.
- F. Referenced industry standards take precedence over standards which are not referenced but recognized in industry as applicable.
- G. Non-referenced standards are not directly applicable to the Work, except as a general requirement of whether the Work complies with standards recognized in the construction industry.

1.03 LOCATION OF REFERENCES

- A. Valley Library, Oregon State University.

1.04 SCHEDULE OF REFERENCED ASSOCIATIONS

AIA	American Institute of Architects
	WWW.AIA.ORG

AISC	American Institute of Steel Construction WWW.AISC.ORG
AISI	American Iron and Steel Institute WWW.STEEL.ORG
ANSI	American National Standards Institute WWW.ANSI.ORG
APA	American Plywood Association WWW.APAWOOD.ORG
ASHRAE	American Society of Heating, Refrigerating, and Air Conditioning Engineers WWW.ASHRAE.ORG
ASTM	American Society for Testing and Materials WWW.ASTM.ORG
AWPA	American Wood Protection Association WWW.AWPA.COM
AWS	American Welding Society WWW.AWS.ORG
BIA	Masonry Institute of America WWW.MASONRYINSTITUTE.ORG
BOLI	Oregon Bureau of Labor and Industries WWW.BOLI.STATE.OR.US
CCB	Construction Contractors Board WWW.OREGON.GOV.CCB/
CDA	Copper Development Association WWW.COPPER.ORG
CISPI	Cast Iron Soil Pipe Institute WWW.CISPI.ORG
CSI	Construction Specification Institute WWW.CSINET.ORG
DEQ	Department of Environmental Quality (Oregon) WWW.OREGON.GOV/DEQ/
DHI	Door and Hardware Institute

	WWW.DHI.ORG
DOT	Department of Transportation WWW.DOT.GOV
EPA	U.S. Environmental Protection Agency WWW.EPA.GOV
FM	Factory Mutual System WWW.FMGLOBAL.COM
FS	Federal Specification General Services Administration Specifications and Consumer Information Distribution Section (WFSIS) WWW.GSA.GOV/PORTAL/CONTENT/103856
IBC	International Building Code WWW.ICCSAFE.ORG
ICBO	International Conference of Building Officials PUBLICECODES.CITATION.COM/ICOD/IBG/INDEX.HTM
IRS	Internal Revenue Service WWW.IRS.GOV
ISA	Instrumentation Systems and Automation Society WWW.ISA.ORG
NAAMM	National Association of Architectural Metal Manufacturers WWW.NAAMM.ORG
NBFU	National Board of Fire Underwriters WWW.NFPA.ORG
NEC	National Electric Code WWW.NECPLUS.ORG
NEMA	National Electrical Manufacturers' Association WWW.NEMA.ORG
NESC	National Electrical Safety Code WWW.IEEE.ORG
NFPA	National Fire Protection Association WWW.NFPA.ORG
NRCA	National Roofing Contractors' Association WWW.NRCA.NET

OAR	Oregon Administrative Rules ARCWEB.SOS.STATE.OR.US/404.HTML
OESP	State of Oregon Electrical Specialty Code http://www.bcd.oregon.gov/programs/online_codes.html
ORS	Oregon Revised Statutes LANDRU.LEG.STATE.OR.US/ORS/
OSHA	Occupational Safety and Health Administration WWW.OSHA.GOV
OSSC	Oregon Structural Specialty Code http://www.bcd.oregon.gov/programs/online_codes.html
PS	Product Standard STANDARDS.GOV/STANDARDS.CFM
SDI	Steel Door Institute WWW.STEELDOOR.ORG
SMACNA	Sheet Metal and Air Conditioning Contractors' National Association WWW.SMACNA.ORG
SPRI	Single Ply Roofing Institute WWW.SPRI.ORG
SSPC	Steel Structures Painting Council WWW.SSPC.ORG
SWRI	Sealing, Waterproofing and Restoration Institute WWW.SWIRONLNE.ORG
UBC	Uniform Building Code (See ICBO)
UFC	Uniform Fire Code WWW.NFPA.ORG
UL	Underwriters' Laboratories, Inc. WWW.UL.COM
UMC	Uniform Mechanical Code WWW.UBC.COM
UPC	Uniform Plumbing Code WWW.UBC.COM
WHL	Warnock Hersey Laboratories

WWW.INTEK.COM/MARKS/WH/

WCLIB West Coast Lumber Inspection Bureau
WWW.WCLIB.ORG

WWPA Western Wood Products Association
WWW.WWPA.ORG

END OF SECTION

SECTION 01 45 00

QUALITY CONTROL

PART 1 GENERAL

1.01 SECTION INCLUDES

- A. Codes, regulations and permits.
- B. Procedures for quality control.

1.02 OWNER RESPONSIBILITIES

- A. Owner will employ and pay for services of an independent testing laboratory to perform inspection, sampling and testing as required by local building authority.
- B. Owner's Authorized Representative will provide on-site observation during construction.

1.03 CODES, REGULATIONS AND PERMITS

- A. All Work shall conform with the Oregon Structural Specialty Code (OSSC) based on the International Building Code (IBC), as amended by the State of Oregon Building Codes Division and the edition designated by the governing authority.
- B. Contractor shall comply with all applicable state and local construction codes.
- C. References to codes, Specifications and standards referred to in the Contract Documents shall mean, and are intended to be, the latest edition, amendment or revision of such reference standard in effect as of the date of these Contract Documents.
- D. The Owner shall be responsible for all permits and City of Corvallis plan review fees; the Contractor shall be responsible for all licenses and associated fees required for the Project.
- E. Contractor shall arrange and attend all required permit inspections and furnish evidence of approved City inspection reports per Section 01 77 00.

1.04 QUALITY OF WORK

- A. It is the true and specific intent of these Specifications that quality of Work on all phases of the construction and embracing all the trade sections shall be of high quality performed by workers skilled in their trade and performing their Work only according to the standard of best practice of the trade.
- B. All manufactured articles, materials, and equipment shall be applied, installed, connected, erected, used, cleaned and conditioned in accordance with manufacturer's directions unless otherwise specified.
- C. If Work is required in a manner to make it impossible to produce first quality Work, or should discrepancies appear among Contract Documents, request

interpretation from Architect before proceeding with Work.

- D. Failure to secure interpretation may cause rejection by Architect or owner of installation.

1.05 LAYOUT

- A. Be responsible for properly laying out the Work and for lines and measurements for the Work.
- B. Verify the figures shown on the drawings before laying out the Work and report errors or inaccuracies to the Architect before commencing Work.
- C. Strict compliance with maximum slopes is required. Accessible parking spaces and adjacent access aisles with slope exceeding 2% in any direction, as determined by OSU, shall be removed and replaced by the contractor at their expense.
- D. Strict compliance with maximum slopes is required. New sidewalks exceeding 1:20 slope or with cross slope exceeding 2%, as determined by OSU, shall be removed and replaced by the contractor at their expense. Ramps exceeding 1:16 slope or with cross slope exceeding 2%, as determined by OSU, shall be removed and replaced by the contractor at their expense.

1.06 SUPERVISION

- A. The Contractor shall maintain effective supervision on the project at all times Work is being performed.
- B. The superintendent shall be the same person throughout the project and shall attend the preconstruction conference.

1.07 INSPECTIONS AND TESTING

- A. Contractor shall notify the Owner at least twenty-four (24) hours in advance of any required progress inspection or final inspection including final punch list inspection.
- B. Cooperate with laboratory personnel, provide access to Work and furnish incidental equipment material and labor required for field testing and sample taking.

1.08 EVALUATION OF TESTS AND INSPECTIONS

- A. Results of laboratory and/or field control tests and inspections shall be the principal basis upon which satisfactory completion of Work shall be judged.
- B. If results of tests and inspections indicate Work is below requirements of Contract Documents, that portion of Work is subject to rejection.

1.09 ADJUSTMENTS

- A. Remove and replace Work so rejected at Contractor's expense including costs of subsequent tests and inspections until Work meets requirements of Contract

Documents.

- B. The Owner reserves the right to perform any testing as may be required to determine compliance with the Contract Documents.
- C. Costs for such testing will be the Owner's responsibility unless testing indicates noncompliance. Cost for such testing indicating noncompliance shall be borne by the Contractor.
- D. Noncomplying Work shall be corrected and testing will be repeated until the Work complies with the Contract Documents.
- E. Contractor will pay costs for retesting noncomplying Work.

END OF SECTION

SECTION 01 51 00

CONSTRUCTION FACILITIES AND TEMPORARY CONTROLS

PART 1 GENERAL

1.01 SECTION INCLUDES

- A. This Section specifies requirements for temporary services and facilities, including utilities, construction and support facilities, security and protection.

1.02 REQUIREMENTS OF REGULATORY AGENCIES

- A. Regulations: Comply with industry standards and applicable laws and regulations of authorities having jurisdiction.
- B. Standards: Comply with NFPA Code 241, "Building Construction and Demolition Operations", ANSI-A10 Series standards for "Safety Requirements for Construction and Demolition".
- C. Electrical Service: Comply with NEMA, NEC and UL standards and regulations for temporary electric service; install service in compliance with National Electric Code (NFPA 70).
- D. Inspections: Arrange for authorities having jurisdiction to inspect and test each temporary utility before use; obtain required certifications and permits if required.

1.03 PROTECTION

- A. Protect sidewalks, asphalt paving, concrete, trees, shrubs, and lawn areas at all times from damage resulting from construction activities.
- B. Prevent materials from clogging catch basins and yard drains; leave drains clean and in proper working condition.
- C. Protect Existing Irrigation Systems:
 - 1. In the event damage occurs to an underground irrigation system as a direct result of a Contractor's activities, the Contractor shall repair/replace or be assessed a charge at the discretion of the Owner.
 - 2. If repairs are to be made by the Contractor, the repairs will be inspected by the Owner's Authorized Representative prior to backfilling.
 - 3. Any galvanized pipe that requires repair shall be repaired at a threaded coupling, not by use of a compression coupling.
- D. Protect Existing Air Handling Systems:
 - 1. Contractor shall be responsible for protection of the cleanliness of the existing air handling system at all times. This protection shall include:
 - a. During site work or building demolition, prefilters shall be provided and maintained on all building outside air intakes at all times throughout the construction duration.
 - b. During any interior work that may create dust in the interior space and

adjacent corridor/hallways, air filters shall be provided and maintained on all affected air return and exhaust grilles. Where air flow in or out of the space is not required, all air duct openings shall be temporarily blanked off with plywood or sheet metal.

- c. Prior to starting any work, the Contractor shall record and submit to the Owner's Authorized Representative, pressure readings across all existing air handler air filter banks before installation of new prefilters.
 - d. Upon completion of all Work affecting existing air handling systems, the Contractor shall remove all temporary filters, covers and associated parts and restore the system to its original operating condition unless otherwise stated elsewhere in the Contract Documents
- E. Clean, repair, resurface, or restore existing surfaces to their original, or better, condition, or completely replace such surfaces to match existing, where damaged by construction operations.
- F. Security is the responsibility of the Contractor.
- G. Construction Debris:
- 1. Debris shall not be allowed to remain around the buildings during performance of Work, but shall be disposed of as rapidly as it accumulates.
 - 2. On completion of Work, the buildings and grounds shall be left in a condition that is equal to or better than original condition.
 - 3. In case of failure to do so, the Owner may remove rubbish and charge the cost to the Contractor.
- H. The Contractor shall manage a safe job environment for both the safety of all the people around the Work site as well as the safety of the Owner's and general public's property.
- I. The Contractor shall provide and maintain suitable barricades, shelters, lights, and danger signals during the progress of the Work; they shall meet the requirements of the local building code and OSHA.

1.04 DRAINAGE

- A. Verify that all rain drains in the construction areas are in working order and notify the Owner's Authorized Representative in writing of any rain drains that are plugged, prior to the start of the Work.
- B. Start of Work will be considered as acknowledgment that all drains are clear and in good working order.
- C. All drains shall be left in a clean and proper working condition.

1.05 CONSTRUCTION PROJECT SAFETY FORM

- A. Contractor shall submit to the Owner, prior to signing the Contract, the completed "Construction Project Safety Form", which is provided with instructions at the end of this Section.

1.06 TEMPORARY UTILITIES

- A. Temporary Utilities:
 - 1. Prepare a schedule indicating dates for implementation and termination of each temporary utility.
 - 2. At the earliest feasible time, when acceptable to the Owner, change over from use of temporary service to use of the permanent service.
- B. Conditions of Use:
 - 1. Keep temporary services and facilities clean and neat in appearance.
 - 2. Operate in a safe and efficient manner.
 - 3. Take necessary fire prevention measures.
 - 4. Do not overload facilities or permit them to interfere with progress.
 - 5. Do not allow hazardous, dangerous or unsanitary conditions, or public nuisances to develop or persist on the site.
- C. Electrical Service:
 - 1. Service limited to 20 amp 120V circuits will be paid for by the Owner.
 - 2. Connection to the service shall be the responsibility of the Contractor, with the Owner's approval.
 - 3. Coordinate with the Owner's Authorized Representative.
- D. Water Service:
 - 1. Service in reasonable quantities for the Project will be paid for by the Owner.
 - 2. Connection to the service shall be the responsibility of the Contractor, with the Owner's approval.
 - 3. Coordinate with the Owner's Authorized Representative.

1.07 TEMPORARY SUPPORT FACILITIES

- A. Temporary Sanitary Facilities:
 - 1. Provide and maintain an adequate number of facilities for the use of all persons employed on the Work during construction.
 - 2. Provide enclosed, weatherproof facilities with heat as required.
 - 3. Use of new or existing Owner's facilities will not be permitted.
- B. Temporary Heat and Ventilation:
 - 1. As necessary, provide temporary heat and ventilation required by construction activities, for curing or drying of completed installations or protection of installed construction from adverse effects of low temperatures or high humidity. Select safe equipment that will not have a harmful effect on completed installations or elements being installed. Coordinate ventilation requirements to produce the ambient condition required and minimize consumption of energy.
- C. Telephone Equipment: Provide telephone communications at project site.
- D. Existing Services:
 - 1. Do not interrupt any existing service.

2. Prior request and approval of the Owner's Representative will enable the Owner to shut down any utility required by the Work.
3. Contractor shall not shut down utilities.

1.08 TEMPORARY BARRIERS AND ENCLOSURES

- A. Provide barriers and fencing to prevent unauthorized entry to construction areas and to protect existing facilities and adjacent properties from damage.
- B. Provide Commercial grade chain link fence construction.
- C. Provide 6 foot high fence around construction site as directed by Owner's Authorized Representative; equip with vehicular and pedestrian gates with lock.
- D. Exterior Closures: Provide temporary secured, weather-tight closures at exterior openings, to permit acceptable working conditions and protection of the Work.
- E. Interior Closures:
 1. Provide temporary floor to ceiling partitions (not plastic sheeting) and ceilings as required to separate work areas from Owner occupied areas, to prevent penetration of dust and moisture into Owner occupied areas, to reduce construction noise, and to prevent damage to existing materials and equipment.
 2. Paint surfaces exposed to view from Owner occupied areas.

1.09 ODORS

- A. Work that causes excessive odors shall be performed only after coordination with the Owner's Authorized Representative. Filtering of air intakes to units may be required to prevent odors and vapors from entering the buildings.
- B. Contractor shall provide 7 days advance notice to the Owner's Authorized Representative in order for advance notice to be forwarded to building occupants. Work stoppage may occur if advance notification has not been coordinated or odors and vapors from the work are found to generate complaints from building occupants.

1.10 FIRE SAFETY

- A. Ensure that required exit routes remain unobstructed while building is occupied.
- B. Abide by all fire safety requirements for buildings under construction, alteration or demolition as required by Article 87, of the Uniform Fire Code as adopted by the State of Oregon.
- C. An emergency telephone shall be provided on site. Cellular telephone equipment is acceptable.
- D. Fire Suppression Equipment:
 1. Install and maintain temporary fire protection facilities of the types needed to protect against reasonably predictable and controllable fire losses. Comply with NFPA 10 "Standard for Portable Fire Extinguishers", and NFPA 241 "Standard for Safeguarding Construction, Alterations and

Demolition Operations".

2. Maintain equipment in working condition with current inspection certificate attached to each.
3. Locate fire extinguishers where convenient and effective for their intended purpose, but not less than one extinguisher on each floor at or near each usable stairwell.
4. Store combustible materials in containers in fire-safe locations.
5. Maintain unobstructed access to fire extinguishers, fire hydrants, temporary fire protection facilities, stairways, and other access routes for fighting fires.
6. Provide continual supervision of welding operations, combustion type temporary heating units, and similar sources of fire ignition.
7. When possible, relocate hot work to a designated hot work area.
8. If the materials or equipment cannot be relocated to a designated hot work area, use the least hazardous form of hot work that will get the job done and prepare the area properly.
9. Manage mobile hot work using the formal hot work permit system. (mentioned in the next bullet point and also a directive in the OSU Hot Work Safety Program)
10. Make sure both fire protection and hot work equipment work properly.
11. Train all personnel involved in hot work operations and activities so that they have the understanding, knowledge, and skills necessary to safely perform their jobs.

1.11 CONSTRUCTION AIDS

- A. Scaffolding: comply with applicable OSHA requirements.
- B. Material Handling Equipment:
 1. Provide necessary cranes, hoists, towers, or other lifting devices.
 2. Use only experienced operators.
 3. Remove equipment as soon as possible after task is ended.
 4. Coordinate placement of such equipment with Owner's Authorized Representative.
 5. Obtain required permits and meet requirement of governing authorities regarding applicable regulations.
- C. Materials or debris shall not be allowed to free fall from building.
- D. The use of chutes or conveyors must be approved by Owner.

1.12 TEMPORARY CONTROLS

- A. Water Control:
 1. Maintain excavations free of water.
 2. Provide, operate, and maintain necessary pumping equipment.
- B. Protection:
 1. Protect installed Work and provide special protection where specified in individual specification sections.
 2. Prohibit traffic or storage upon waterproofed or roofed surfaces.

- C. Security:
 - 1. Provide security and facilities to protect Work and existing facilities and Owner's operations from unauthorized entry, vandalism, or theft.
 - 2. Coordinate operations with Owner's Authorized Representative.

- D. Temporary Traffic Control /Pedestrian Accessibility
 - 1. A continuous route for all pedestrians, including persons with disabilities and bicyclists, shall be maintained at all times. When existing pedestrian facilities are disrupted, closed, or relocated in a construction zone, temporary pedestrian facilities shall be provided.
 - 2. Temporary pedestrian facilities should be safe and accessible. There should be no curbs or abrupt changes in grade that could cause tripping or be a barrier to wheelchair use.
 - 3. Signage shall be provided directing people to the temporary accessible route. The signage shall include the International Symbol of Accessibility.
 - 4. Contractors shall not block temporary walkways with vehicles, equipment, construction materials, signs, trash, or other objects that might prohibit pedestrian passage.
 - 5. Construction equipment and equipment operation must be separated from any open walkways. At construction zones, pedestrian fences or other protective barriers shall be provided to prevent access into the construction zone.

1.13 PROJECT SIGNAGE

- A. Contractor is permitted to post only one project identification sign based on the following example:

OSU TYPICAL JOB SIGN

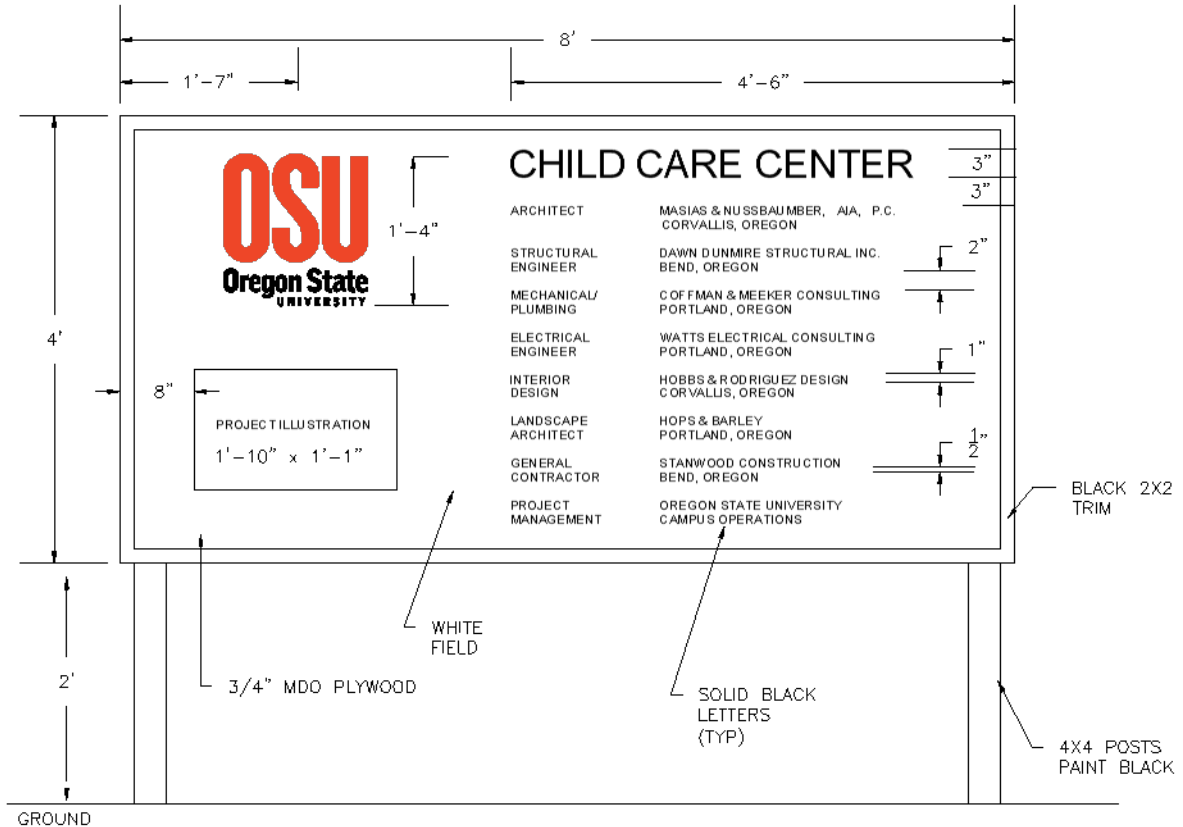

1.14 PREPARATION

- A. Consult with Owner to review jobsite areas required for field offices, material storage and stockpiles, equipment storage, access to different locations, etc.

1.15 PERFORMANCE

- A. Confine equipment, apparatus, and storage of material to work limits. The Owner will not be responsible for protection of materials and equipment from damage, pilfering, etc.
- B. Install temporary facilities in such a manner that the installed work will not be damaged.
- C. Do not use facilities of existing building unless authorized in writing by the Owner.
- D. Effective September 1, 2012, OSU became a non-smoking campus and smoking is prohibited on all Campus property.
- E. Keep facilities well maintained.
- F. Relocate temporary facilities as required during job progress.

- G. At Substantial Completion, clean and renovate permanent facilities that have been used during the construction period, including but not limited to:
1. Replace air filters and clean inside of ductwork and housings.
 2. Replace significantly worn parts and parts that have been subject to unusual operating conditions.
 3. Replace lamps that are burned out or noticeably dimmed by substantial hours of use.

END OF SECTION

Oregon State University Construction and Maintenance Safety Requirements

EH&S, 130 Oak Creek Building, Corvallis, OR 97331-7405, (541) 737-2505,
FAX (541) 737-9090

Complete OSU Construction and Maintenance Safety Form - Send completed documents (including Site Safety Plan and all separate answer pages) to Construction Contract Administration along with the signed contract and bonds.

Project Isolation - All construction and remodeling activities regardless of size and/or scope must be fenced, barricaded, or otherwise protected to restrict entrance and to ensure the safety of those in the general area. See isolation requirements.

Site Safety Plan - A site safety plan will be required and will address:

- General Information
- Emergency Information
- Key Organization Personnel
- Hazard Evaluation/Facility Impact
- Emergency Procedures
- Work Zones
- Security Measures
- Fire Protection

A model plan is attached. This form can be used if another plan has not already been prepared. Contact OSU Environmental Health & Safety for more information 737-2505.

Isolation Requirements

General: All construction, maintenance, and remodeling activities, regardless of size or scope, must be fenced, barricaded, or otherwise isolated to restrict entrance and to ensure the safety of those in the general area.

Outdoor Activities: Outdoor projects require the following perimeter isolation:

- A six foot chain-link fence, with controlled access points, extending in all directions around the excavation or building site such that no area of the construction is accessible to pedestrians or unauthorized personnel or vehicles.
- Isolation area will include vehicle loading and unloading areas.
- At the University's option, other barricading plans may be accepted. These may apply to projects such as road resurfacing, parking lot striping, exterior building water proofing, deliveries, etc. Contact EH&S regarding other barricading plans.

Overnight: Any excavation across or adjacent to sidewalks or pathways which must be left open overnight, must be identified with working, blinking construction lights in addition to solid barricades

Indoor Activities: Indoor construction or maintenance projects which will create dust, potentially hazardous fumes or vapors, or offensive odors are subject to the following isolation:

- Areas where existing doors can provide isolation will be labeled "Construction Area-- Authorized Personnel Only".

- All other areas will be isolated by a solid barrier. The minimum barrier allowed is 4 mil poly sheeting sealed to prevent migration of dust.
- Mechanical ventilation may be required.
- A solid wall is required if building envelope is opened to the outside.

Contractor Responsibilities

- The contractor will provide all barricading, isolation, and fencing material. OSU will not provide any materials.
- The contractor will also provide all appropriate warning and detour signs when sidewalks, exits, or roads are closed.
- Contractor will provide all other construction area signs.

OSU Construction and Maintenance Safety Form

Send completed safety documents to Construction Contract Administration with contract and bonds.

Date: _____ Project: _____

Start Date: _____ Completion date: _____

Contractor: _____ Contact: _____

Work # _____ 24 hr #: _____

OSU Project Mgr: _____ Work / 24hr #'s: _____

Dept Contact: _____ OSU EH&S Contact: _____

Preconstruction meeting? **Y N** Date/Time/Location: _____

For the following items, prepare answers on a separate sheet for all items marked "Yes". Precede each answer with the appropriate item number. All boxes need to be checked

Y	N	For This Project	If YES, then:
		1 Will any confined spaces be accessed?	Describe location of entry Specify location of permit Notify EH&S prior to entry See SAF 209
		2 Will hot work be performed (welding, cutting, brazing, etc.)?	Provide min. 5# 2A10BC extinguisher within 10 ft If indoors - provide and describe ventilation See SAF 214
		3 Any products brought to campus?	Provide MSDS on site prior to first use; Make available to OSU on request
		4 Will lead paint be impacted?	Describe plan to limit contamination
		5 Will asbestos-containing-material be impacted?	Coordinate with OSU asbestos manager
		6 Will <u>any</u> materials (construction debris, soil, water, etc) be removed from campus?	Describe in detail identity and disposition of material (how, where)
		7 Any open trenches or holes?	Describe isolation procedures (see Page 1)
		8 Will a crane be used?	Describe crane safety plan (include plan to prevent loads above occupied areas)
		9 Is this project building a new facility, a major remodel?	Provide Site Safety plan Describe isolation procedures (see Page 1)
		10 Is this a minor remodeling project?	Provide, or fill out model Site Safety Plan form (see Page 3) Describe isolation procedures (see Page 1)
		11 Will air contamination be produced (e.g. dust, CO, solvent vapors, VOCs, odors)?	Describe project ventilation and isolation Indicate position of building air intake(s)
		12 Will there be noise > 85 dB?	Describe noise minimization plan
		13 Will this project use a scaffold or an external chute?	Describe isolation, dust control, installation
		14 Will this project involve a working surface >6' above a lower level	Describe fall protection
		15 Will any "blind" saw-cuts or penetrations be made in existing foundations, floors, ceilings and/or walls?	Describe plan for detecting and protecting power lines or other building utility lines.

EH&S Review: _____ Date: _____

Model Site Safety Plan

1. General Information

Contractor name _____
 Address _____
 City, State, Zip _____
 Site Safety Officer _____ Project Dates _____
 Project Name _____

2. Emergency Information

Emergency Response	911	OSU EH&S and OSU Facilities Services must be notified in the event of an emergency
Hazardous Materials Spill		
MSDS on-site location		
OSU EH&S	(541) 737-2505	
Facilities Services	(541) 737-2969	

3. Contractor Key Personnel

	Name	Phone	Emergency Contact
Company Owner			
Project Manager			
Job Supervisor			
Site Safety Officer			
Other Responsible Individual			
24 Hour Notification			

List of employees on site _____

4. Hazard Evaluation/ Facility Impact	
Physical	Yes / No
Heavy Equipment	
Noise	
Heat	
Elevation	
Radiation Materials	
Excavations	
Underground Utilities	
Confined Spaces	
Fire Prevention	
Electrical	

5. Emergencies
Services
Evacuation Route
First Aid Location
Hazardous Materials Spill Procedure

6. Work Zones

Material Storage _____
 Parking locations _____
 Individuals with OSU keys _____
 Access issues _____

7. Security measures

8. Fire protection

SECTION 01 56 39

TREE AND PLANTING PROTECTION

PART 1 GENERAL

1.01 SECTION INCLUDES

- A. Section includes temporary fencing, barricades, and guards to protect trees, plants and groundcovers not indicated to be removed, as necessary and required to prevent damage above and below grade.

1.02 DEFINITIONS

- A. Dripline: Outer perimeter of branches of any tree or plant.
- B. Groundcover: Includes but not limited to plants and grass.

1.03 PERFORMANCE REQUIREMENTS

- A. The Contractor shall exercise utmost care to protect existing trees and plants designated to remain and shall comply with all protection requirements provided by Owner and City of Corvallis as conveyed through the Owner's Authorized Representative.
- B. The Contractor shall install tree protection fencing as detailed and shall prevent damage to shrubs, groundcover, trees, root systems, soil, bark, foliage, branches and limbs due to construction activities, including but not limited to:
 - 1. Soil contamination, erosion, and compaction.
 - 2. Excessive wetting, and ponding due to storm water, and construction run-off.
 - 3. Alteration of grade, stockpiling of soil, debris, and materials.
 - 4. Damage to soil, roots, bark, trunk, limbs, branches, and foliage.
 - 5. Prevent unauthorized cutting, breaking, skinning and bruising of roots, branches, and bark.

1.04 SUBMITTALS

- A. Procedural proposal for tree and plant protection, describe methods of protection, and stabilization, provide drawings and supporting documentation as directed.
- B. Contractor's Condition Inspection; include written report and color photographs.

1.05 PROJECT CONDITIONS

- A. Install protection during initial mobilization at the Work site, and maintain until substantial completion.
- B. If, in the opinion of the Owner's arborist, additional protection is required, the Contractor shall install additional fencing as directed and without cost to the Owner.

- C. The location and requirements for additional fencing shall be determined by the Owner's arborist prior to, and at any time during the course of the Work.
- D. Fencing:
 - 1. Fencing shall be installed at the tree and plant protection areas as detailed on Plans, or as directed by the Owner's Authorized Representative.
 - 2. Tree and plant protection fences shall remain in place until all Work is completed and shall not be removed or relocated without the approval of the Owner's Authorized Representative.
- E. Driving and Parking:
 - 1. Not permitted off paved surfaces without the approval of the Owner's Authorized Representative.
 - 2. When approved, the Contractor shall place plywood of sufficient thickness and width to support vehicles and prevent rutting on the area to be driven on.
 - 3. Care shall also be taken with respect to existing lawn sprinkler systems.
- F. Storage of materials and Debris: Not permitted off paved surfaces.

PART 2 PRODUCTS

2.01 MANUFACTURED COMPONENTS

- A. Chain Link Fencing: 11 gage galvanized chain link, six feet. tall, and 1.5 inch inside diameter galvanized steel line posts and 2.5 inch inside diameter corner posts, provide lockable gates as necessary.

PART 3 EXECUTION

3.01 EXAMINATION

- A. Verification of Conditions: Inspect trees, plants, and groundcovers, document existing conditions prior to installation of protection.

3.02 EXECUTION

- A. Pruning and Cutting of Roots, Branches and Foliage:
 - 1. Review conditions with Architect or Owner prior to need for work, and proceed as directed.
 - 2. All pruning to be done by Owner's landscape maintenance personnel or ISA Certified arborist under the direction of Owner's Landscape Management Department.
 - 3. Perform pruning and cutting with sharp instruments intended for the purpose; do not break or chop.
- B. Root Cuttings:

1. Carefully and cleanly cut roots and branches of trees indicated to be left standing where such roots and branches obstruct new construction.
 2. Protect exposed roots with wet burlap until they can be covered with soil.
- C. Excavation and Trenching Within Drip Lines:
1. Permitted where indicated, and at other specifically approved locations.
 2. Tunnel under or around roots by hand digging or boring.
 3. Do not cut main lateral roots and tap roots over one inch diameter; cut smaller roots which interfere with installation of new Work.
 4. Do not allow exposed roots to dry out before permanent backfill is placed; provide temporary earth cover, or pack with peat moss and wrap with burlap.
 5. Water and maintain roots in moist condition and temporarily support and protect from damage until permanently relocated and covered with backfill.
- D. Existing Grading: Maintain within drip line of trees and plants unless otherwise indicated on the drawing and approved by the Owner's Authorized Representative.
- E. Tree Protection:
1. Provide temporary fence complying with Section 01 51 00 for protection of trees to remain.
 2. Extend fencing ten feet beyond dripline, except where greater distance is required for protection of Elm trees.
 3. Prevent entry into protected areas except as authorized in writing by the Owner's Authorized Representative.

3.03 REPAIR AND REPLACEMENT OF TREES AND PLANTS

- A. Repair trees or shrubs damaged by construction operations as directed by the Owner.
- B. Make repairs promptly after damage occurs to prevent progressive deterioration of damaged trees.
- C. Damaged Trees, Shrubs and Groundcover:
1. Replace where Owner's Authorized Representative determines restoration to normal growth pattern is not possible; plant and maintain as directed.
 2. Replacement trees up to 13 inches caliper and shrubs up to 4 feet tall: Same size as damaged tree or shrub, species selected by the Owner's Authorized Representative.
 3. Trees over 13 inch caliper and shrubs greater than 4 feet tall: Compensate Owner as determined by an acceptable consulting arborist registered with the American Society of Consulting Arborists.
 4. Replacement groundcovers: Same size and quality as damaged species selected by Owner's Authorized Representative.

END OF SECTION

SECTION 01 60 00

PRODUCT REQUIREMENTS

PART 1 GENERAL

1.01 SECTION INCLUDES

- A. Summary:
 - 1. Product options.
 - 2. Owner-furnished products.
 - 3. Product delivery, storage and handling.

1.02 PRODUCTS

- A. Products:
 - 1. New material, machinery, components, equipment, fixtures, and systems forming the Work, but does not include machinery and equipment used for preparation, fabrication, conveying and erection of the Work.
 - 2. Products may also include existing materials or components specifically identified for reuse.
- B. Use interchangeable components of the same manufacture for similar components.
- C. Unless otherwise specified, all material and equipment shall be new; free from defects impairing strength, durability, and appearance; of current manufacture.
- D. Items specified shall be considered minimum as to quality, function, capacity, and suitability for application intended.
- E. Items incorporated into the Work shall conform to applicable specifications and standards designated, and shall be of size, make, type, and quality specified.
- F. Design, fabricate, and assemble in accordance with current best engineering, industry, and shop practices.
- G. Manufacture like parts of duplicate units to standard size and gauge to make them interchangeable.
- H. Two or more items of the same kind shall be identical and made by the same manufacturer.

1.03 PRODUCT OPTIONS

- A. Products Specified by Reference Standards or by Description Only: Any product meeting those standards or description.
- B. Products Specified by Naming One or More Manufacturers with a Provision for Substitutions: Submit a request for substitution for any manufacturer not named.
- C. Products Specified by Naming One [or More] Manufacturer[s]: Products of manufacturer[s] named and meeting specifications, no options or substitutions

allowed.

D. Substitution Procedure: Under Section 01 25 00.

1.04 REUSE OF EXISTING PRODUCTS

- A. Except as specifically indicated or specified, materials and equipment removed from existing construction shall not be used in the completed Work.
- B. For material and equipment specifically indicated or specified to be reused in the Work:
 - 1. Use care in removal, handling, storage, and reinstallation to assure proper function in the completed Work.
 - 2. Arrange for transportation, storage, and handling of products which require off-site storage, restoration, or renovation.
 - 3. Remove and reinstall mechanical units, vents, guys, antennae, and electrical and grounding wires or conduits.

1.05 OWNER FURNISHED PRODUCTS

- A. Designate delivery dates of Owner-furnished items in the construction schedule.
- B. Receive, unload, store and handle Owner-furnished items at the site; protect from damage.

1.06 DELIVERY, STORAGE AND HANDLING

- A. Transport, handle, store and protect products in accordance with manufacturer's instructions.
- B. Arrange deliveries in accordance with construction schedules; coordinate to avoid conflict with Work and site conditions.
- C. Deliver and store products in undamaged condition in manufacturer's original containers or packaging with identifying labels intact and legible.
- D. Inspect shipments to assure compliance with Contract Documents and reviewed submittals, and that products are undamaged.
- E. Prevent soiling or damage to products or packaging.
- F. Interior Storage: Maintain required temperature and humidity ranges. Verify that Owner furnished storage meets product manufacturer's requirements.
- G. Exterior Storage:
 - 1. Store materials above ground to prevent soiling and/or moisture infiltration.
 - 2. Cover materials with waterproof breathable sheet coverings; provide adequate ventilation.
 - 3. All storage locations to be approved in advance by the Owner.
- H. Arrange storage to provide access for inspection.
- I. Coordinate with Owner's Authorized Representative all on-site storage activities.

J. Provide for security of stored products.

END OF SECTION

SECTION 01 73 29

CUTTING AND PATCHING

PART 1 GENERAL

1.01 SECTION INCLUDES

- A. Requirements and limitations for cutting and patching of Work.

1.02 RELATED SECTIONS

- A. Section 01 25 00, Product Substitution Procedures.
- B. Section 01 33 23, Shop Drawings, Product Data, Samples

1.03 SUBMITTALS

- A. Submit written request in advance of cutting or alteration which affects:
 - 1. Structural integrity of any element of the Work.
 - 2. Efficiency, maintenance, or safety of any operational element.
 - 3. Visual qualities of sight exposed elements.
 - 4. Work of Owner or separate contractor.
- B. Include in request:
 - 1. Identification of project.
 - 2. Location and description of affected work.
 - 3. Necessity for cutting or alteration.
 - 4. Description of proposed work, and products to be used.
 - 5. Alternatives to cutting and patching.
 - 6. Effect on work of Owner or separate contractor.
 - 7. Written permission of affected separate contractor.
 - 8. Date and time work will be executed.

PART 2 PRODUCTS

2.01 MATERIALS

- A. Primary Products: Those required for original installation.
- B. Product Substitution: For any proposed change in materials, submit request for substitution under provisions of Section 01 25 00.

PART 3 EXECUTION

3.01 EXAMINATION

- A. Inspect existing conditions prior to commencing Work, including elements subject to damage or movement during cutting and patching.

- B. After uncovering existing work, inspect conditions affecting performance of Work.
- C. Beginning of cutting or patching means acceptance of existing conditions.

3.02 PREPARATION

- A. Provide temporary supports to ensure structural integrity of the Work.
- B. Provide devices and methods to protect other portions of the Work from damage.
- C. Provide protection from elements for areas which may be exposed by uncovering work.

3.03 CUTTING AND PATCHING

- A. Execute cutting, fitting and patching to complete work.
- B. Fit products together, to integrate with other work.
- C. Remove and replace defective or non-conforming work.
- D. Provide openings in the work for penetration of mechanical and electrical work.

3.04 PERFORMANCE

- A. Execute work by methods to avoid damage to other Work, and which will provide appropriate surfaces to receive patching and finishing.
- B. Cut rigid materials using masonry saw or core drill. Pneumatic tools are not allowed without prior approval from Owner's Authorized Representative.
- C. Restore work with new products in accordance with requirements of Contract Documents.
- D. At penetrations of fire rated walls, partitions, ceiling or floor construction, completely seal voids with approved fire rated material, to full thickness of the penetrated element.
- E. Refinishing:
 - 1. Refinish surfaces to match adjacent finish.
 - 2. For continuous surfaces, refinish to nearest intersection or natural break.
 - 3. For an assembly, refinish entire unit.

END OF SECTION

SECTION 01 74 00

CLEANING

PART 1 GENERAL

1.01 SECTION INCLUDES

- A. Related requirements specified elsewhere, cleaning for specific products or work: Specification section for that work.
- B. Maintain premises and public properties free from accumulations of waste, debris, and rubbish, caused by operations.
- C. At completion of Work remove waste materials, rubbish, tools, equipment, machinery and surplus materials, and clean all sight-exposed surfaces; leave project clean and ready for occupancy.

1.02 QUALITY ASSURANCE

- A. Standards: Maintain project in accord with applicable safety and insurance standards.
- B. Hazard Control:
 - 1. Store volatile wastes in covered metal containers.
 - 2. Provide adequate ventilation during use of volatile or noxious substances.

1.03 MATERIALS

- A. Use only cleaning materials recommended by manufacturer of surface to be cleaned.
- B. Use cleaning materials only on surfaces recommended by cleaning material manufacturer.

1.04 DURING CONSTRUCTION:

- A. Wet down dry materials and rubbish to lay dust and prevent blowing dust.
- B. At reasonable intervals during progress of Work clean site and public properties, and dispose of waste materials, debris and rubbish.
- C. Provide on-site containers for collection of waste materials, debris and rubbish.
- D. Remove waste materials, debris and rubbish from site and legally dispose of at public or private dumping areas off Owner's property.
- E. Vacuum clean interior building areas when ready to receive finish painting, and continue vacuum cleaning on an as-needed basis until project is ready for Substantial Completion or occupancy.
- F. Handle materials in a controlled manner with as few handlings as possible; do not drop or throw materials from heights.

1.05 FINAL CLEANING

- A. Employ experienced workers, or professional cleaners, for final cleaning.
- B. In preparation for Substantial Completion or occupancy, conduct final inspection of sight-exposed interior and exterior surfaces, and of concealed spaces.
- C. Remove grease, dust, dirt, stains, labels, and other foreign materials from exposed interior and exterior finished surfaces.
- D. Remove putty, paint, labels, lubricants, etc., from windows, mirrors, and sash, and then polish, taking care not to scratch glass.
- E. Vacuum carpeting (shampoo where required), removing debris and excess nap.
- F. Repair, patch and touch up marred surfaces to specified finish, to match adjacent surfaces.
- G. Replace air filters where units were operated during construction.
- H. Maintain cleaning until project, or portion thereof, is occupied by Owner.

END OF SECTION

SECTION 01 77 00

CONTRACT CLOSEOUT

PART 1 GENERAL

1.01 DESCRIPTION

- A. The requirements specified in this section relate to all Contractors individually performing under these Contract Documents:
 - 1. Project Record Documents.
 - 2. Final review and payment.
- B. Related work specified elsewhere:
 - 1. OSU General Conditions.
 - 2. Shop Drawings, Product Data and Samples, Section 01 33 23.

1.02 PROJECT RECORD DOCUMENTS

- A. The Project Record Documents shall be organized to include the following information:
 - 1. Table of Contents
 - 2. Project Team List
 - 3. Specifications (Including Addenda and Change Orders)
 - 4. Drawings
 - 5. Inspection Reports, as applicable
 - 6. Signed Warranty(ies)
 - 7. Maintenance Instructions
- B. Two sets of the Project Record Documents shall be submitted for review upon 75% completion of the Work.
- C. Project Record Documents shall be submitted electronically to the Owner. Hard copies will not be accepted.
- D. The project team list shall include the name, address, and phone number of the Owner, Contractor, Inspector, Subcontractors, and the materials manufacturers.
- E. Legibly mark each Specification section to indicate actual as-built condition indicating changes in the Work made by addenda or change order or actual materials used and actual manufacturer(s) used.
- F. Maintain current and accurate as-built mark-ups during construction and make available to Owner's Authorized Representative upon request.
- G. Legibly mark the drawings to indicate actual as-built conditions indicating changes in the Work made by addenda or change order or actual conditions which differ from the drawings.
- H. Redraw or provide new drawings as required for a complete as-built set of drawings. The Contractor shall maintain current and accurate as-built mark-ups

during construction and make available to Owner's Authorized Representative.

- I. Include inspection reports if applicable.
- J. Include, in a single section, all copies of the Project's labor and material warranties clearly marked to identify the Owner's responsibilities under the terms of each warranty and the section of Work that each warranty covers. One set must be clearly marked as containing original documents.
- K. In the case of an elevator installation, the Contractor's and manufacturer's warranty shall provide for the Owner's right to respond to emergency/car failure situations for the purpose of extricating individuals trapped in the elevator.
- L. Include maintenance instructions complete with technical information and name, address, and phone number of the Contractor(s) and manufacturer(s) of each material and product.

1.03 FINAL REVIEW AND PAYMENT

- A. Prior to completion, the Contractor shall inspect the Work and make a Punch-list noting all items that are incomplete and/or incorrect.
- B. The Contractor shall notify all Subcontractors in writing of incomplete and/or incorrect items. Notify far enough in advance of the completion date that the Work can be completed on schedule. Said Work shall be immediately corrected.
- C. Should conditions prevail which prohibit some elements of the Work from being accomplished, but the work-in-place will perform the primary function (i.e., painting cannot be completed due to high moisture content of masonry walls.) the Contractor shall record the reason with this Punch-list item requesting temporary delay in completion from the Owner in writing.
- D. Notify the Owner in writing that all items are completed and ready for final review or else that the Work product is fully usable, but some listed deficiencies remain to be completed. Submit all record documents at this time.
- E. The Owner will review all documents. When the documents include a Contractor's request for delay in completion, the Owner will review all Work which is certified as complete to the best knowledge of the Contractor. The Owner will also review the listed incomplete Work and assign a value to such uncompleted work.
- F. The Contractor shall make the required corrections to the Work expeditiously. A letter will be addressed to the Contractor informing the Contractor of the project status.
- G. When Contract closeout procedures are completed and all Punch-list deficiencies have been corrected, provide Owner with final corrected Project Record Documents based on Owner's preliminary review. Correct Project Record Documents shall be in electronic format.

- H. Final Completion by the Owner will be documented and the Contractor will receive written notice of acceptance of the Work and notification that final payment may be billed and released.
- I. All warranties shall commence and become effective beginning on the date of Substantial Completion.

END OF SECTION

SECTION 23 05 00
COMMON WORK RESULTS FOR HVAC

PART 1 GENERAL

1.1 SUMMARY

- A. The intent of Division 23, HVAC Specifications and the accompanying Drawings is to provide a complete and workable facility with complete systems as shown, specified and required by applicable codes. Include work specified in Division 23, HVAC and shown on the accompanying Drawings, including appurtenances, connections, etc., in the finished job.
- B. The Drawings that accompany the Division 23, HVAC Specifications are diagrammatic. They do not show every offset, bend, tee, or elbow which may be required to install work in the space provided and avoid conflicts. Offsets and transitions assumed at a minimum at each duct crossing, structural penetrations through shear walls or beams, structural grids where ceiling heights are restricted, and at piping mains. Follow the Drawing as closely as is practical to do so and install additional bends, offsets and elbows where required by local conditions from measurements taken at the Building, subject to approval, and without additional cost to the Owner. The right is reserved to make any reasonable changes in outlet location prior to roughing-in, without cost impact.
- C. The General and Supplemental Conditions apply to this Division, including but not limited to:
 - 1. Drawings and specifications.
 - 2. Public ordinances, permits.
 - 3. Include payments and fees required by governing authorities for work of this Division.
- D. Division 01, General Requirements, General Requirements, applies to this Division.

1.2 RELATED SECTIONS

- A. Division 01, General Requirements
- B. Division 23, Heating, Ventilating, and Air Conditioning (HVAC)

1.3 QUALITY ASSURANCE

- A. Regulatory Requirements:
 - 1. Products and equipment prohibited from containing pentabrominated, octabrominated, and decabrominated diphenyl ethers. Where products or equipment within this specification contain these banned substances, provide complying products and equipment from approved manufacturers with equal performance characteristics.
 - 2. General: Work and materials conforms to the local and State codes, and Federal, State and other applicable laws and regulations.
 - 3. Contractor responsible for obtaining and payment for permits, licenses, and inspection certificates required in accordance with provisions of Contract Documents.
- B. New materials and equipment. Work of good quality, free of faults and defects and in conformance with the Contract Documents.
- C. Apparatus built and installed to deliver its full rated capacity at the efficiency for which it was designed.
- D. The entire mechanical system and apparatus operates at full capacity without objectionable noise or vibration.
- E. Install equipment level and true. Housekeeping pads and curbs account for floor or roof slope.

- F. Materials and Equipment:
1. Each piece of equipment furnished meet detailed requirements of the Drawings and Specifications and suitable for the installation shown. Equipment not meeting requirements will not be acceptable, even though specified by name along with other manufacturers.
 2. Where two or more units of the same class of equipment are furnished, use products of the same manufacturer. Component parts of the entire system need not be products of same manufacturer.
 3. Furnish materials and equipment of size, make, type, and quality herein specified.
 4. Equipment scheduled by performance or model number considered the basis of the design. If other specified manufacturer's equipment is provided in lieu of the basis of design equipment the contractor is responsible for changes and costs which may be necessary to accommodate this equipment, including different sizes and locations for connections, different electrical characteristics, different dimensions, different access requirements, or any other differences which impact the project.
- G. Workmanship:
1. General: Install materials in a neat and professional manner.
 2. Manufacturer's Instructions:
 - a. Follow manufacturer's directions where they cover points not specifically indicated.
 - b. If conflict with the Drawings and Division 23, HVAC Specifications, obtain clarification before starting work.
- H. Cutting and Patching:
1. Cutting, patching, and repairing for the proper installation and completion of the work specified in this Division including plastering, masonry work, concrete work, carpentry work, and painting performed by skilled craftsmen of each respective trade in conformance with the appropriate Division of Work.
 2. Additional openings required in building construction made by drilling or cutting. Use of jackhammer is specifically prohibited.
 3. Fill holes which are cut oversize so that a tight fit is obtained around the sleeves passing through.
 4. Do not pierce beams or columns without permission of Owner and then only as directed.
 5. Restore new or existing work cut or damaged to its original condition. Where alterations disturb lawns, paving, walks, etc., surfaces repaired, refinished, and left in condition existing prior to commencement of work.

1.4 SUBMITTALS

- A. Shop Drawings:
1. The Contract Drawings indicate the general layout of the piping, ductwork, and various items of equipment. Coordination with other trades and with field conditions will be required. For this purpose, prepare Shop Drawings of piping, ductwork, and equipment installations. Shop Drawings new drawings prepared by Contractor and not reproductions or tracings of Engineer's Drawings. Overlay drawings with shop drawings of other trades and check for conflicts. Drawings the same size as Engineer's Drawings with title block similar to Contract Drawings and identifying Engineer's Drawing number or any reference drawings. Drawings fully dimensioned including both plan and elevation dimensions. Shop drawings cannot be used to make scope changes.
 2. Prepare in two-dimensional format.

3. Include but are not limited to:
 - a. Complete floor plans with sheet metal and HVAC piping to a minimum of 1/-inch equals 1-foot scale.
 - b. Sheet metal and HVAC piping of mechanical and fan rooms to a minimum of 1/4-inch equals 1-foot scale.
 - c. Sections of congested areas to a minimum of 1/2-inch equals 1-foot scale.
 - d. Controls and Instrumentation: Scale and drawing sizes to suit controls supplier.
 - e. Fabricated Equipment: Scale and drawing sizes to suit contractor except equipment not less than 1/4-inch equals 1-foot scale.
 - f. Superplot plans of above ground work with a colored overlay of trades including, but not limited to, HVAC piping, HVAC equipment, plumbing piping and equipment, sprinklers, lighting, lighting controls, cable tray, fire alarm devices, electrical power conduit, and ceiling system to a minimum of 1/4-inch equals 1-foot scale.
 - g. Slab penetration drawings of HVAC, plumbing, sprinklers, lighting and electrical to a minimum of 1/4-inch equals 1-foot scale.
 4. Submit shop drawings for review prior to beginning fabrication. Additional shop drawings may be requested when it appears that coordination issues are not being resolved in the field or when there is a question as to whether contract documents are being complied with or the design intent is being met.
- B. Product Data:
1. In general, submit product data for review on scheduled pieces of equipment, on equipment requiring electrical connections or connections by other trades, and as required by each specification section or by Drawing notes. Include manufacturer's detailed shop drawings, specifications, and data sheets. Data sheets include capacities, RPM, BHP, pressure drop, design and operating pressures, temperatures, and similar data. Manufacturer's abbreviations or codes are not acceptable.
 2. List the name of the motor manufacturer and service factor for each piece of equipment.
 3. Indicate equipment operating weights including bases and weight distribution at support points.
 4. In the case of equipment such as wiring devices, time switches, valves, etc., specified by specific catalog number, a statement of conformance will suffice.
- C. Submission Requirements:
1. Shop Drawings and Product Data:
 - a. Refer to Division 01, General Requirements for additional requirements related to submittals.
 - b. Submit copies of shop drawings and product data for Work of Division 23, HVAC in a 3-ring loose leaf binder with each item filed under a tab and labeled with its respective specification section number, Article and paragraph, and mark if applicable.
 - c. Submit electronic copies of shop drawings and product data for Work of Division 23, HVAC in PDF format with each item filed under a folder and labeled with its respective specification section number, Article and paragraph and mark if applicable.
 - d. Include a complete index in the original submittal. Indicate both original items submitted and note stragglers that will be submitted at a later date to avoid delay in submitting.

- e. The bulk of the shop drawings and product data, excepting Controls and Instrumentation, included with the original submittal. Controls and Instrumentation submittals may lag but complete when submitted. Partial submittals will not be accepted. Other stragglers submitted after return of the original binder includes a tab similar to that originally submitted. Upon receipt of the returned late submittal, insert them in the previously submitted binder.
- D. Contractor Responsibilities:
 - 1. Submit submittals one time and are in proper order.
 - 2. Ensure that equipment will fit in the space provided.
 - 3. Assure that deviations from Drawings and Specifications are specifically noted in the submittals. Failure to comply will void review automatically.

1.5 AS-BUILT DRAWINGS

- A. Provide record drawings at the end of the project on CD-ROM.
- B. Record Drawings: Provide hard copies and pdf format.
 - 1. Drawings include the following:
 - a. Project Specific Titleblock.
 - b. Notations reflecting the as built conditions of any additions to or variations from the construction documents provided as part of the BIM coordination, RFIs, ASIs, Owner Changes, and Field Coordination.

1.6 OPERATING AND MAINTENANCE MANUAL, PARTS LISTS, AND OWNER'S INSTRUCTIONS

- A. Refer to Division 01, General Requirements for additional requirements.
- B. Submit three bound copies of manufacturer's operation and maintenance instruction manuals and parts lists for each piece of equipment or item requiring servicing. Literature on 8-1/2-inch by 11-inch sheets or catalogs suitable for side binding. Submit data when the work is substantially complete, packaged separately, and clearly identified in durable 3-ring binder. Include name and contact information for location of source parts and service for each piece of equipment. Clearly mark and label in each submittal, the piece of equipment provided with the proper nameplate and model number identified. Provide wiring diagrams for electrically powered equipment.
- C. Instruct Owner thoroughly in proper operation of equipment and systems, in accordance with manufacturer's instruction manuals. Operating instructions cover phases of control.
- D. Furnish competent engineer knowledgeable in this building system for minimum of one 8-hour days to instruct Owner in operation and maintenance of systems and equipment. Keep a log of this instruction including dates, times, subjects, and those present and present such log when requested by Engineer.

1.7 PROJECT CONDITIONS

- A. Existing Conditions:
 - 1. Prior to bidding, verify and become familiar with existing conditions by visiting the site, and include factors which may affect the execution of this Work.
 - 2. Include related costs in the initial bid proposal.
- B. Coordinate exact requirements governed by actual job conditions. Check information and report discrepancies before fabricating work. Report changes in time to avoid unnecessary work.
- C. Coordinate shutdown and start-up of existing, temporary, and new systems and utilities. Notify Owner, the City, and Utility Company.

1.8 WARRANTY

- A. Provide a written guaranty covering the work of this Division (for a period of one calendar year from the date of acceptance by the Owner) as required by the General Conditions.

- B. Provide manufacturer's written warranties for material and equipment furnished under this Division insuring parts and labor for a period of one year from the date of Owner acceptance of Work of this Division.
- C. Correct warranty items promptly upon notification.

1.9 PROVISIONS FOR LARGE EQUIPMENT

- A. Coordinate pathway into building for large equipment.

1.10 TEST REPORTS AND CERTIFICATES

- A. Submit one copy of test reports and certificates specified herein to the Engineer.

1.11 SUBSTITUTIONS

- A. Submit requests for product substitutions in accordance with the Instructions to Bidders and the General and Supplemental Conditions.

PART 2 PRODUCTS

2.1 ACCESS PANELS

- A. Furnish under this Division as specified in another Division of work.

2.2 PIPE AND DUCT SLEEVES

- A. Interior Wall and Floor Sleeves: 18 gauge galvanized steel, or another pre-approved system.
- B. Interior Wall and Floor Sleeves (fire rated): Fire rated and water tight system approved by Authority Having Jurisdiction and Owners Insurance underwriter, with rating equal to floor or wall penetration, and designed specifically for the floor or wall construction, piping material, size and service.
- C. Exterior Wall Sleeves: Cast iron
- D. On Grade Floor Sleeves: Same as exterior wall sleeves.
- E. Water Tight Sleeves: Combination steel pipe sleeves with water stop and anchor plate; Link Seal Model WS, mated with synthetic rubber links interlocked with bolts and nuts; Link Seal Model LS.

2.3 FLOOR, WALL AND CEILING PLATES

- A. Furnish stamped split type plates as follows:
 - 1. Floor Plates: Cast brass, chromium plated.
 - 2. Wall and Ceiling Plates: Spun aluminum.

2.4 MACHINERY GUARDS

- A. Furnish guards for protection on rotating and moving parts of equipment. Provide guards for metal fan drives and motor pulleys, regardless of being enclosed in a metal cabinet.
- B. Design guards so as not to restrict air flow at fan inlets resulting in reduced capacity.
- C. Provide shaft holes in guards for easy use of tachometers at pulley centers. Guards easily removable for pulley adjustment or removal and changing of belts.
- D. Guards meet OSHA requirements including back plates.
- E. Provide inlet and outlet screens on fans in plenums or where exposed to personnel.

2.5 ELECTRICAL EQUIPMENT

- A. General: Equipment and installed work as specified under Division 26, Electrical.
- B. Coordinate with the electrical Drawings and electrical contractor for minimum electrical equipment bracing requirements based on the available fault current rating at the bus of the panelboard or switchboard serving the piece of equipment. Provide equipment with a Short Circuit Current Rating (SCCR) that meets the bracing requirement.

C. Motors – AC Induction:

1. Furnish as integral part of driven equipment.
2. Drip proof induction type with ball bearings unless noted otherwise.
3. Motors 1 hp and above premium energy efficient type, except for emergency equipment motors.
4. Built to NEMA Standards for the service intended.
5. Rated for voltage specified, suitable for operation within the range of 10 percent above to 10 percent below the specified voltage.
6. Energy Efficient Motors:
 - a. Baldor
 - b. Westinghouse
 - c. General Electric
 - d. Or approved equal.
7. Motors meet the efficiency standards identified in the table below as determined using the IEEE Method B test at full load.

MINIMUM MOTOR EFFICIENCIES					
		RPM			
		IEEE 112B Efficiency			
HP	KW	900	1200	1800	3600
1	0.75	--	82.5	85.5	80.0
1.5	1.15	--	86.5	86.5	85.5
2	1.53	--	87.5	86.5	86.5
3	2.3	84.0	89.5	89.5	88.5
5	3.8	85.5	89.5	89.5	89.5
7.5	5.6	87.5	91.7	91.7	91.0
10	7.5	88.5	91.7	91.7	91.7
15	7.5	88.5	91.7	92.4	91.7
20	15.9	90.2	92.4	93.0	92.4
25	18.8	91.0	93.0	93.6	93.0
30	22.5	91.0	93.6	94.1	93.0
40	30.0	91.7	94.1	94.5	93.6
50	37.5	92.4	94.1	94.5	94.1
60	45.0	93.0	94.5	95.0	94.1
75	56.3	93.0	95.0	95.4	94.5

8. Refer to Equipment Schedules on the Drawings for motor horsepower, voltage, and phase.
9. Refer to individual product sections for additional motor requirements.
10. Furnish motors on belt drive equipment of nominal nameplate horsepower not less than 120 percent of equipment brake horsepower required for performance specified.
11. Built-in thermal overload protection, or be protected externally with separate thermal overload devices with low voltage release or lockout. Hermetically sealed motors have quick trip devices.
12. Motors controlled by variable frequency drives inverter duty rated and have Class F insulation or better. Withstand repeated voltage peaks of 1600V with rise times of 0.1 microseconds and greater in accordance with NEMA Standard MG1 Part 31.
13. Motors served from variable frequency drives equipped with shaft grounding system which provide a path for current to flow between the shaft and motor frame. SGS or equal.

14. Motors located in environment air plenums not tied to air handling functions totally enclosed type motors.
 15. Motors installed on cooling towers totally enclosed type TEFC.
- D. Motors – Electronic Commutation (EC):
1. Furnished as integral part of driven equipment.
 2. Permanently lubricated with ball bearings unless noted otherwise.
 3. Internal motor circuitry converts AC power supplied to the motor to DC power to operate the motor.
 4. Speed controllable down to 20 percent of full speed.
 5. Motor efficiency at a minimum of 85 percent at all speeds.
 6. Refer to Equipment Schedules on the Drawings for motor horsepower, voltage, and phase.
 7. Refer to individual product sections for additional motor requirements.
 8. Built-in thermal overload protection, or be protected externally with separate thermal overload devices with low voltage release or lockout. Quick trip devices hermetically sealed motors.
 9. Motors located in environment air plenums not tied to air handling functions totally enclosed type motors.
- E. Starters: Provided under Division 26, Electrical, suitable for performing the control functions required, with the exception of self-contained equipment and where the starters are furnished as part of the control package.
- F. Equipment Wiring:
1. Interconnecting wiring within or on a piece of mechanical equipment provided with the equipment unless shown otherwise.
 2. This does not include the wiring of motors, starters and controllers provided under Division 26, Electrical.
- G. Control Wiring: Control wiring for mechanical equipment provided under Section 23 09 00, Instrumentation and Controls for HVAC.
- H. Codes: Electrical equipment and products bear the UL label as required by governing codes and ordinances.

PART 3 EXECUTION

3.1 ACCESS PANELS

- A. Install in accord with manufacturer's recommendations, coordinated with architectural features.
- B. Provide 2-hour fire rated doors where required bearing the UL label.
- C. Furnish 18-inch by 18-inch panels for ceilings and for access to equipment in soffits and shafts, and 12-inch by 12-inch for walls unless indicated otherwise.
- D. Furnish where indicated and where required to access valves, fire/smoke dampers, trap primers, shock arresters, and other appurtenances requiring operation, service or maintenance. Submit proposed locations for review prior to installation.

3.2 SLEEVES

- A. Interior Floor and Wall Sleeves:
1. Provide sleeves large enough to provide 3/4-inch clearances around pipe or ductwork.
 2. Where pipe or ductwork is insulated, insulation passes continuously through sleeve with 3/4-inch clearance between insulation and sleeve.

3. Penetrations through mechanical room and fan room floors watertight by packing with safining insulation and sealing with Tremco Dymeric Sealant or approved system.
- B. Sleeves through Rated Floors and Walls: Similar to interior sleeves except install fire rated system approved by Authority Having Jurisdiction and Owners insurance underwriter, with rating equal to floor or wall penetration, and designed specifically for the floor or wall construction, piping or duct material, size and service.
- C. Sleeves specified or indicated at fire damper penetrations take precedence over this article.
- D. Exterior Wall Sleeves Above Grade: Similar to interior wall sleeves except caulk outside with Tremco Dymeric Sealant.
- E. Floor sleeves maintain a water barrier by providing a water tight seal or they extend 1-inch above finished floor except through mechanical equipment room floors and shafts where sleeves extend 2-inches above finished floor level. Sleeves through roof extend 8-inches above roof. Wall sleeves flush with face of wall unless otherwise indicated.
- F. Do not support pipes by resting pipe clamps on floor sleeves. Supplementary members provided so pipes are floor supported.
- G. Special sleeves detailed on drawings take precedence over this section.

3.3 CLEANING

- A. General: Clean mechanical equipment, piping and ductwork of stampings and markings (except those required by codes), iron cuttings, and other refuse.
- B. Painted Surfaces: Clean scratched or marred painted surfaces of rust or other foreign matter and paint with matching color industrial enamel, except as otherwise noted.
- C. Additional requirements are specified under specific Sections of this Division.

3.4 EQUIPMENT PROTECTION

- A. Keep pipe, ductwork, and conduit openings closed by means of plugs or caps to prevent the entrance of foreign matter. Protect piping, conduit, ductwork, equipment, and apparatus against dirty water, chemical or mechanical damage both before and after installation. Restore damaged or contaminated fixtures, equipment, or apparatus to original conditions or replace at no cost to the Owner.
- B. Protect bright finished shafts, bearing housings, and similar items until in service. No rust will be permitted.
- C. Cover or otherwise suitably protect equipment and materials stored on the job site.

3.5 ACCESSIBILITY

- A. General: Locate valves, thermometers, cleanout fittings and other indicating equipment or specialties requiring frequent reading, adjustments, inspection, repairs, and removal or replacement conveniently and accessibly with reference to the finished building.
- B. Thermometers and Gauges: Install thermometers and gauges so as to be easily read from the floors, platforms, and walkways.

3.6 FLOOR, WALL, AND CEILING PLATES

- A. Install on piping and ductwork passing through finished walls, floors, ceilings, partitions, and plaster furrings. Plates completely cover opening around pipe and duct.
- B. Secure wall and ceiling plates to pipe, insulation, or structure.
- C. Plates not penetrate insulation vapor barriers.
- D. Plates not required in mechanical rooms or unfinished spaces.

3.7 ADJUSTING AND CLEANING

- A. Before operating any equipment or systems, make thorough check to determine that systems have been flushed and cleaned as required and equipment has been properly installed, lubricated, and serviced. Check factory instructions to see that installations have been made accordingly and that recommended lubricants have been used.

- B. Use particular care in lubricating bearings to avoid damage by over-lubrication and blowing out seals. Check equipment for damage that may have occurred during shipment, after delivery, or during installation. Repair damaged equipment as approved or replace with new equipment.

3.8 ELECTRICAL EQUIPMENT

- A. Ductwork or piping for mechanical systems not serving electrical space not installed in any switchgear room, transformer vault, telephone room, or electric closet except as indicated.
- B. Ductwork or piping for mechanical systems not to pass over switchboards or electrical panelboards. Where conflicts exist, bring to attention of Architect.

3.9 EQUIPMENT CONNECTIONS

- A. Make final connections to equipment specified in sections other than Division 23, HVAC of the specifications and Owner furnished equipment in accordance with manufacturer's instructions and shop drawings furnished and as indicated.
- B. Piping:
 - 1. Connections include chilled water supply and return.
 - 2. Provide valves and specialties as specified and as detailed on the Drawings. Provide increasers, reducers, and any other fittings required for complete installation.
 - 3. Independently support piping connections supported to prevent undue strain on equipment.

END OF SECTION

SECTION 23 05 14
VARIABLE FREQUENCY DRIVES FOR HVAC EQUIPMENT

PART 1 GENERAL

1.1 SUMMARY

- A. This Section includes:
 - 1. Variable Frequency Drives

1.2 RELATED SECTIONS

- A. Division 01, General Requirements
- B. Division 23, Heating, Ventilating, and Air Conditioning (HVAC)
- C. Section 23 09 00, Instrumentation and Controls for HVAC

1.3 SUBMITTALS

- A. Submit the following:
 - 1. Product data on variable frequency drives and related components.
 - 2. Startup log/check list showing successful operation.
 - 3. Operation and maintenance data.

1.4 WARRANTIES

- A. Provide 24-month warranty from date of shipment to include full replacement covering parts and labor.

PART 2 PRODUCTS

2.1 VARIABLE FREQUENCY DRIVES

- A. Manufacturers:
 - 1. ABB
 - 2. Other Manufacturers: Submit substitution request.
- B. General Description:
 - 1. Variable Frequency AC Motor Drive (VFD):
 - a. Pulse width modulated (PWM) inverter type.
 - b. Designed to convert 60 Hz input power to adjustable frequency output power to provide positive speed control to standard induction motors.
 - c. Dedicated variable torque design for specific use with centrifugal loads.
 - 2. Provide completely solid state variable frequency power and logic unit.
 - 3. Speed control to be stepless throughout the range under variable torque load on continuous basis. Speed controlled by remote building energy management system providing 4-20MA input signal to drive and remote start/stop signal. Coordinate with Section 23 09 00, Instrumentation.
 - 4. Provide adjustable frequency control with diode bridge/capacity input designed to provide high, constant power factor of 0.95 regardless of load or speed and eliminate SCR line noise.
 - 5. Equipment will be designed and manufactured in accordance with applicable current NEMA and IEEE recommendations and be designed for installation per NEC. Equipment will be UL listed and bear the UL label.
 - 6. Control suitable for operation in ambient temperatures of 32 degrees F to 104 degrees F.
 - 7. Factory tested with an AC induction motor 100 percent loaded and temperature cycled within an environmental chamber at 104 degrees F.

- C. Self-Protection and Reliability Features:
1. Adjustable current limit to 60 percent to 110 percent of drive rating.
 2. Adjustable instantaneous overcurrent trip.
 3. Under voltage trip.
 4. Over temperature trip.
 5. Short circuit protection phase to phase and phase to ground faults phase rotation insensitive.
 6. Momentary power loss, more than 17 milliseconds.
 7. Transient protection against normal transients and surges in incoming power line.
 8. Orderly shutdown in event of any of above conditions, drive designed to shut down safely without component failure.
 9. Provide visual indication and manual reset.
- D. Standard Features:
1. Drive Logic: Microprocessor based
 2. Control Logic: Isolated from power circuitry.
 3. Standalone operation to facilitate start up and troubleshooting procedures.
 4. UL 508C listed for drives serving a single motor or UL 508A listed for drives serving multiple motors, for use on distribution systems with 22,000 AIC.
 5. Output voltages equal to applied input voltage.
 6. Isolated signal inputs.
 7. Frequency Stability. Output frequency will be held to +0.1 percent of maximum frequency regardless of load, +10 percent input voltage change or temperature changes within ambient specification.
 8. Built-in digital display indicates output frequency, voltage, and current and provide indication of over current, over voltage, current limit, ground fault, over temperature, input power on, minimum or maximum speed adjustment, power on, fault condition. Display on panel face.
 9. Start/Stop Control - Controlled decelerated stop.
 10. Primary and secondary fused for a control circuit transformer.
 11. Minimum and maximum speed control.
 12. Adjustable Accel/Decel - independently adjustable 10-100 second.
 13. Hand-Off auto switches.
 14. Programmable Auto Restart - after power outage.
 15. Provide fused disconnect, including auxiliary contacts to isolate control circuit when disconnect is in "off" position, except fused disconnects not required where packaged equipment is provided with a single point connection with single point disconnect and internal overcurrent protection for VFD and motors.
 16. Remote contacts for fault, and on/off status.
 17. Adjustable motor output voltage.
 18. Analog output voltage of 0-10 VDC, -20 MA proportional to control output frequency.
 19. Provide a NEMA 1 enclosure for indoor applications and NEMA 3R enclosure for outdoor applications to isolate each motor starter and control section with its associated disconnect switch.
 20. Manual speed control for each motor.
 21. Provide RF, and EMI, noise suppression network to limit RF and EM interference.

22. Provide isolated analog output signals for volts, amps, and frequency, from each VFD for connection to the building energy management system.
 23. Provide line (input) reactors.
 24. Provide output filters for VFD's located more than 25 conductor feet from the motor they serve. Output reactors permit VFD's to be located up to 350-feet from the motors they serve.
 25. Design VFD to catch spinning load in forward and reverse direction.
 26. Harmonic Calculations: Perform on manufacturer supplied Harmonic Analysis program to provide conformance with IEEE 519-1992.
- E. Communications:
1. Provide factory installed communication chip for direct network connection to DDC Control System specified in Section 23 09 00, Instrumentation and Controls for HVAC. Interface allows for control and interface functions specified herein and in Section 23 09 00, Instrumentation and Controls for HVAC. Interface control functions and information includes, but not be limited to the following:
 - a. Start/Stop
 - b. Change Directions
 - c. Drive Fault
 - d. Drive Fault Codes
 - e. Reset Drive
 - f. Percent Output
 - g. Speed
 - h. Power
 - i. Drive Temp
 - j. KWH
 - k. Run Time
 2. Provide isolated analog output signals for volts, amps and frequency from each VFD for connection to the DDC Control System specified in Section 23 09 00, Instrumentation and Controls for HVAC.
 3. Provide RS485 communications port and programming software capability.

PART 3 EXECUTION

3.1 VARIABLE FREQUENCY DRIVE INSTALLATION

- A. Install VFD in accordance with manufacturer's written installation instructions.
- B. Install on strut support stand.
- C. Provide one drive for each motor as scheduled.

3.2 START UP

- A. General: Comply with manufacturer's instructions for startup.
- B. Provide under direct supervision of the manufacturer's representative with factory trained personnel.

3.3 FIELD QUALITY CONTROL

- A. Prior to installation, manufacturer's representative coordinate variable speed drive control interface with the controls contractor and verify that intended installation (controls, wiring, etc.) complies with the manufacturer's recommendations.

- B. Field Test: Except where initial variable speed drive operation clearly shows the performance meets or exceeds the requirements, test to show compliance. Tests performed by the manufacturer's representative in the presence of the Engineer.

END OF SECTION

SECTION 23 05 18
HVAC EXPANSION COMPENSATION

PART 1 GENERAL

1.1 RELATED DOCUMENTS

- A. Drawings and general provisions of the Contract, including General and Supplementary Conditions and Division 01, General Requirements Specification Sections, apply to this Section.
- B. The provisions of Division 23, Heating, Ventilation and Air Conditioning (HVAC) Section 23 05 00, Common Work Results for HVAC, apply to work specified in this Section.

1.2 SUMMARY

- A. This Section includes:
 - 1. Expansion Joints and Compensators
 - 2. Expansion Loops/Seismic Expansion Joints

1.3 RELATED SECTIONS

- A. Division 01, General Requirements
- B. Division 23, Heating, Ventilating, and Air Conditioning (HVAC)
- C. Section 23 05 29, Hangers, Supports and Anchors for HVAC
- D. Section 23 05 48, Vibration and Seismic Controls for HVAC Piping and Equipment
- E. Section 23 21 13, Pipe and Pipe Fittings HVAC

1.4 QUALITY ASSURANCE

- A. Design expansion joints, pipe guides, and related supports, braces, and anchorages to building structure to absorb thermal expansion and contraction of piping and terminal movement, as well as to resist the static and dynamic loads due to fluid flow at design conditions, hydraulic testing pressures, and seismic forces.
- B. Expansion Joints, Guides, and Related Supports, Braces, and Anchorage to Building Structure: Provide design and details bearing the seal of a professional engineer registered in the State having jurisdiction.
- C. Use expansion joints in straight lengths of rigid pipe anchored and guided in accordance with best practices recommendations of ASHRAE and ASME B31.9.
- D. Avoid use of expansion joints in conjunction with U-bends or other piping systems with inherent flexibility, such as piping with flexible mechanical couplings.
 - 1. If expansion joints are used in piping with bends, conduct thorough analysis of pipe stresses and deflections with extra care and attention paid to radial thrust capacity of pipe guides, braces, and anchors.
- E. Design to include:
 - 1. Pipe stress analysis indicating loads, deflections, and pipe stress at critical points throughout the piping systems under the following conditions:
 - a. At hydraulic design test pressure and ambient water temperature.
 - b. At design operating temperature, pressure, and flow.
 - c. At design occasional seismic loads where required by the building occupancy and risk category as defined in the state and local code or by the authority having jurisdiction.
 - d. Model number, size, location, and details of expansion joints, compensator guides, supports, braces, and anchorage to building structure, with substantiating calculations that the components and building can accept the calculated loads and deflections.

- e. Detailed shop drawings stamped and signed by a registered professional engineer.
- f. Structural details and calculations stamped and signed by a registered professional structural engineer.
- g. Expansion Joints to be designed and manufactured to the current Expansion Joint Manufacturers Association (EJMA) standards. Manufacturer of expansion joints to be certified by EJMA.

1.5 SUBMITTALS

- A. Submit the following:
 - 1. Product Data
 - 2. Shop Drawings showing details of construction, dimensions, arrangement of components, and isolation.
 - 3. Structural Details and Calculations: Submit structural details and calculations substantiating that building structure, anchorages, and fabricated steel braces can safely withstand maximum calculated loads.
 - 4. Specified testing requirements.
 - 5. Operating and Maintenance Data

PART 2 PRODUCTS

2.1 MANUFACTURERS

- A. Expansion Joints and Compensators:
 - 1. Flexonics
 - 2. Keflex
 - 3. Hyspan
 - 4. Metraflex
 - 5. Other Manufacturers: Submit substitution request.
- B. Expansion Loops/Seismic Expansion Joints:
 - 1. Metraflex Metraloop
 - 2. Other Manufacturers: Submit substitution request.

2.2 EXPANSION JOINTS AND COMPENSATORS

- A. Expansion compensators to be of the packless, externally pressurized type to allow for axial movement constructed of stainless steel bellows, stainless steel shroud, integral guide rings, internal liner, limit stops, with drain port and plug.
- B. All materials of construction and pressure ratings shall be appropriate for the application as specified for each piping material and service.

2.3 EXPANSION LOOPS/SEISMIC EXPANSION JOINTS

- A. Flexible stainless steel hose and braid connector.
- B. Connector shall accept differential support displacement without damaging pipe, equipment connections, or support connections.
- C. All materials of construction and pressure ratings shall be appropriate for the application as specified for each piping material and service.

PART 3 EXECUTION

3.1 EXPANSION JOINTS AND COMPENSATORS

- A. Install piping risers in wood structures to compensate for 1/2-inch of shrinkage per floor. Contractor is responsible to determine quantities and locations required.

- B. Install in piping to compensate for thermal expansion and contraction. Responsible to determine quantities and locations required.
- C. Install in other locations indicated on the drawings.
- D. Provide and install pipe alignment guides as recommended by the expansion joint manufacturer with the first guide no more than 4 pipe diameters away from the expansion joint or compensator and second guide no more than 14 pipe diameters from first guide.
- E. Install per manufacturer's installation instructions.

3.2 EXPANSION LOOP / SEISMIC EXPANSION JOINT

- A. Install at building seismic expansion joints.
- B. Install in piping to compensate for thermal expansion and contraction. Contractor is responsible to determine quantities and locations required.
- C. Install in other locations indicated on the drawings.
- D. Install per manufacturer's installation instructions.

END OF SECTION

SECTION 23 05 19
METERS AND GAUGES FOR HVAC

PART 1 GENERAL

1.1 SUMMARY

- A. This Section includes:
 - 1. Thermometers - Water
 - 2. Pressure Gauges - General
 - 3. Differential Pressure Gauges

1.2 RELATED SECTION

- A. Division 01, General Requirements
- B. Division 23, Heating, Ventilating, and Air Conditioning (HVAC)

1.3 SUBMITTALS

- A. Submit the following:
 - 1. Products listed in this Section.
 - 2. Operating and Maintenance Data

PART 2 PRODUCTS

2.1 MANUFACTURERS

- A. Thermometers - Water:
 - 1. Ashcroft
 - 2. Weiss
 - 3. Trerice
 - 4. Marsh
 - 5. Weksler
 - 6. Tel-Tru
 - 7. Other Manufacturers: Submit substitution request.
- B. Pressure Gauges - General:
 - 1. Marsh
 - 2. Ashcroft
 - 3. Weiss
 - 4. Trerice
 - 5. Weksler
 - 6. Tel-Tru
 - 7. Other Manufacturers: Submit substitution request.
- C. Differential Pressure Gauges:
 - 1. Between Rooms: Dwyer magnahelic Model 2000-00, 0-0.25 inches of water range.
 - 2. Across Filters: Dwyer magnahelic Model 2002-AF, 0-2.0 inches of water range with air filter gauge accessory package.

2.2 THERMOMETERS - WATER

- A. Direct mounted 4-1/2-inch dial type, stainless steel case, separable sockets, stem length to penetrate minimum of 1/2 pipe diameter, adjustable face, extension necks where required to clear insulation, accuracy of 1 percent of range.

B. Range:

HVAC Systems	Temperature	Graduations
Chilled Water	25-125 degrees F	1 degrees F

2.3 PRESSURE GAUGES - GENERAL

A. Description: 4-1/2-inch dial, molded black polypropylene turret case.

B. Range:

HVAC Systems	Pressure	Graduations
Chilled Water	0-100 psi	1 psi
Other ranges may be listed on Drawings in which case they take precedence.		

2.4 DIFFERENTIAL PRESSURE GAUGES

A. Description: Surface mounted diaphragm-actuated dial type with zero pointer adjustment. Provide 4-inch minimum dial diameter with black figures on a white background.

B. Tubing: Copper; polytube may be used if concealed inside walls.

PART 3 EXECUTION

3.1 INSTALLATION - GENERAL

- A. Provide gauges where shown on Drawings.
- B. Install gauges as required and as recommended by equipment manufacturer or their representative.
- C. Extend connections, wells, cocks, or gauges to a minimum of 1-inch beyond insulation thickness of the various systems.
- D. Locate gauges so that they may be conveniently read at eye level or easily viewed and read from the floor or from the most likely viewing area, i.e., platform, catwalk, etc.
- E. Install instruments over 6-feet-6-inches above floor, to be viewed from the floor, with face at 30 degrees to horizontal.

3.2 INSTALLATION - PRESSURE GAUGES

- A. Provide instrument gauge cock at inlets. Provide protective siphon on steam gauges.
- B. Locate pressure gauge taps for measuring pressure drop or increase across pumps, coils, condensers, etc., as close to the device as possible.

END OF SECTION

SECTION 23 05 23
GENERAL DUTY VALVES AND SPECIALTIES FOR HVAC

PART 1 GENERAL

1.1 SUMMARY

- A. This Section includes:
1. Gate Valves
 2. Globe Valves
 3. Check Valves
 4. Ball Valves
 5. Butterfly Valves
 6. Balancing Valve
 7. Specialty Valves
 8. System Specialties
 9. Integrated Coil Piping Connector
 10. Diaphragm Expansion Tank System
 11. Bladder Expansion Tank System
 12. Water Buffer Tank
 13. Air Separator – High Efficiency Coalescing
 14. N-Line Air Purger
 15. Pressure Reducing Valve (Closed Hydronic System Feed)
 16. Water Relief Valves
 17. Strainers
 18. Suction Diffusers
 19. Triple Duty Valve
 20. Water Filters
 21. Differential Pressure Regulator Valve

1.2 RELATED SECTIONS

- A. Division 01, General Requirements
- B. Division 23, Heating, Ventilating, and Air Conditioning (HVAC)

1.3 SUBMITTALS

- A. Submit product data.
- B. Submit balancing valve schedule with manufacturer, model, size, flow rate and pressure drop.
- C. Submit automatic flow control valve schedule with manufacturer, model, size, flow rate and pressure drop.

PART 2 PRODUCTS

2.1 MANUFACTURER

- A. General: Where only NIBCO figure numbers are listed, equivalent products by those specified below are acceptable.
- B. Gate Valves:
1. Apollo
 2. Victaulic

3. Crane
 4. Kennedy
 5. Stockham
 6. Milwaukee
 7. Walworth
 8. Hammond
- C. Globe Check:
1. Apollo
 2. Victaulic
 3. Crane
 4. Kennedy
 5. Stockham
 6. Milwaukee
 7. Walworth
 8. Hammond
- D. Check Valves:
1. Mueller
 2. Metraflex
 3. Victaulic
 4. Bell and Gossett
 5. Milwaukee
 6. Gruvlok.
- E. Ball Valves:
1. Gruvlok
 2. Apollo
 3. Crane
 4. Hammond
 5. Milwaukee
 6. Victaulic
- F. Butterfly Valves:
1. Apollo
 2. Victaulic
 3. Gruvlok
 4. Crane
 5. Walworth
 6. Milwaukee
 7. Metraflex
- G. Balancing Valve:
1. DeZurik
 2. Homestead
 3. Bell and Gossett
 4. Armstrong

5. Walworth
 6. Taco
 7. Wheatley
 8. Tour & Andersson
 9. Victaulic
 10. Gruvlok
 11. NIBCO
- H. Automatic Flow Control Valves
1. Griswold
 2. Flow Design
 3. Other Manufacturers: Submit substitution request.
- I. Specialty Valves
- J. System Specialties:
1. Manual Air Vents:
 - a. Coin type
 - b. Dole 9
 - c. Or approved equal.
 2. Automatic Air Vents:
 - a. Hoffman 78
 - b. Amtrol
 - c. Armstrong
 - d. Spirax-Sarco Engineering
 - e. Spirotherm Spirotop
 - f. Other Manufacturers: Submit substitution request.
 3. Pressure/Temperature Test Plug:
 - a. Peterson Engineering, Inc.
 - b. Universal Lancaster
 - c. Sisco
 - d. Tserice
 - e. Other Manufacturers: Submit substitution request.
- K. Bladder Expansion Tank System:
1. Amtrol, Bell & Gossett
 2. Armstrong
 3. Wheatley
 4. Taco
 5. Other Manufacturers: Submit substitution request.
- L. Water Buffer Tank:
1. Cemline
 2. Taco
 3. Bell & Gossett
 4. Amtrol
 5. Wessels Company

6. Bradford-White
 7. A.O. Smith
 8. Other Manufacturers: Submit substitution request.
- M. Air Separator – Centrifugal:
1. Bell & Gossett Rolairtrol
 2. Armstrong
 3. Taco
 4. Amtrol
 5. Wheatley
 6. Other Manufacturers: Submit substitution request.
- N. Pressure Reducing Valve (Closed Hydronic System Feed) :
1. Bell & Gossett
 2. Armstrong
 3. Taco
 4. Amtrol
 5. Cash Acme
 6. Other Manufacturers: Submit substitution request.
- O. Strainers:
1. General:
 - a. NIBCO
 - b. Armstrong
 - c. McAlear Mfg. Co.
 - d. Sarco, Inc.
 - e. Steamflo
 - f. Mueller
 - g. R.P. & C. Company
 - h. Titan Flow Control
 - i. Other Manufacturers: Submit substitution request.
 2. Grooved Coupling Systems:
 - a. Guvlok
 - b. Victaulic
- P. Suction Diffusers:
1. General:
 - a. Bell & Gossett
 - b. Armstrong
 - c. Taco
 - d. Amtrol
 - e. Wheatley
 - f. Paco
 - g. Mueller
 - h. Other Manufacturers: Submit substitution request.

2. Grooved Piping Systems:
 - a. Gruvlok
 - b. Victaulic
3. Grooved Piping Systems:
 - a. Gruvlok
 - b. Victaulic

- Q. Other Manufacturers: Submit substitution request.
- R. Use one manufacturer on valves.
- S. Threaded, flanged, soldered, or grooved valve ends, as applicable to piping system. Refer to Section 23 21 13, Pipe and Pipe Fittings HVAC for allowable fittings.

2.2 GATE VALVES

- A. Bronze Gate: Bronze body, bronze trim, bronze screwed bonnet; solid wedge, 150 psi steam rating (use bonnet on steam service), 300 psi WOG, NIBCO 134.
- B. Iron Gate, OS&Y: Iron body, bronze trim, OS&Y pattern, solid wedge, 150 psi rating; NIBCO 637.

2.3 GLOBE VALVES

- A. Bronze Globe and Angle Globe: Bronze body, bronze mounted, renewable composition disc, 150 psi rating; NIBCO 235 or 335.
- B. Iron Globe: Iron body, bronze mounted, OS&Y pattern, renewable composition disc, 125 psi rating; NIBCO 718-B.

2.4 CHECK VALVES

- A. Horizontal Bronze Swing Check: Bronze body, bronze mounted, regrinding bronze disc, 150 psi steam rating, 300 psi WOG; NIBCO 433-Y.
- B.
- C. Vertical and Silent Check Valves: 250-lb. WOG, iron body, stainless steel trim, wafer type; NIBCO W-960.
- D. Iron Swing Check with Lever and Spring: Iron body, bronze fitted, with adjustable lever and spring; NIBCO F-918-BL&S.

2.5 BALL VALVES

- A. Bronze Ball: Bronze cast body or forged brass, chrome-plated full port ball, with handle, Teflon seat, 300 psi WOG, 150 psi steam; NIBCO 585-70 or Victaulic Series 589.

2.6 BUTTERFLY VALVES

- A. Ductile iron body, electroless-nickel chrome plated disc and stainless steel shaft (shaft offset from the disc centerline to provide complete 360-degree circumferential seating), with lever handle and locking feature on valves 6-inches and less, gear operator on valves 8-inches and over; stem neck length to accommodate insulation where applicable, pressure responsive EPDM liner, 300 psi water; Victaulic MasterSeal, NIBCO 2000, NIBCO 4765.
- B. Copper Grooved Piping System Butterfly Valve: Nylon coated or Cast bronze body per Copper Development Agency-836, ductile iron disc encapsulated with EPDM coating, lever handle up to 6-inches, gear operator on valves 8-inches and greater, stem length to accommodate insulation, 300 psi water; Victaulic Series 608, per ASTM A-584.
 1. Grooved ends manufactured to copper-tubing sizes. Flaring tube or fitting ends to accommodate alternate sized couplings is not permitted.

2.7 BALANCING VALVE

- A. Calibrated:
 - 1. Y-pattern globe style design. Valve to perform the following functions: Precision flow measurement, precision flow balancing, memory stops, positive shut-off to a minimum of 250 psi, drain port suitable for hose bibb fitting. Threaded or solder ends for 1/2-inch through 2-inches. 1/2-inch valve capable of balance to 0.5 GPM. Grooved or flanged ends for 2-1/2-inches through 12-inches. Tour & Andersson, Armstrong CBV, Gruvlok GBV, NIBCO CBV 1710, 737.
 - 2. Size balancing valves based on the published performance curve characteristics for the scheduled flow rate for each location to ensure proper operation at design conditions.

2.8 AUTOMATIC FLOW CONTROL VALVES

- A. Furnish automatic pressure compensating flow control valves.
- B. Valves factory set and calibrated within 5 percent of indicated water flow rate. Provide taps for measuring of flows with quick disconnect valves.
- C. Field adjustable flow rate with adjustable flow control cartridge.
- D. Provide identification tags for each valve indicating type, flow characteristics, etc.
- E. Pressure range of 1-14 psig
- F. 150 psi operating pressure.
- G. Provide strainers and isolation valves separately from flow control valves, where required.
- H. Size flow control valves based on the published performance curve characteristics for the scheduled flow rate for each location to ensure proper operation at design conditions.

2.9 SPECIALTY VALVES

- A. Gauge Cocks: Brass, tee handle, male to female, 200 psi working pressure, 1/4 inch; Conbraco 41 series.
- B. Drain Valves: Bronze globe valve or full port ball valve, garden hose end, cap, and chain 3/4 inch size.

2.10 SYSTEM SPECIALTIES

- A. Automatic Air Vents: Water main type, cast brass body, built-in check valve, 1/8-inch I.P.S. top tapping for moisture discharge, 3/4-inch size, 150 psi operating pressure.
- B. Temperature and Pressure Test Plugs:
 - 1. General: 1/2-inch N.P.T. fitting to receive either a temperature or pressure probe 1/8-inch O.D., fitted with a color coded and marked cap with gasket.
 - 2. Material: Solid brass with valve core of NORDEL.
 - 3. Rating: Minimum 300 psig at 275 degrees F.
 - 4. Gauges and Thermometers: Supply Owner with two pressure gauge adapters with 1/8-inch O.D. probe and two five-inch stem pocket test thermometers 25 degrees - 125 degrees F for chilled water, 40 degrees -240 degrees F for heating water.

2.11 BLADDER EXPANSION TANK SYSTEM

- A. Expansion Tank:
 - 1. Bladder type of welded steel, constructed and stamped in accordance with ASME Code for 125 psi working pressure.
 - 2. Support with steel legs or bases for vertical installation or steel saddles for horizontal installation.
 - 3. Precharge with compressed air to minimum fill pressures as indicated.
 - 4. Replaceable bladder.

2.12 WATER BUFFER TANK

- A. Vertical tank constructed of heavy gauge carbon steel with internal baffle, welded support stand and drain and vent connections.
- B. Rated for 150 psig working pressure in accordance with ASME Boiler and Pressure Vessel Code Section VIII, Division 1.
- C. Flanged inlet and outlet pipe connections.
- D. Capacity and connection sizes per schedule on Drawings.

2.13 AIR SEPARATOR – CENTRIFUGAL

- A. Fabricated steel tank constructed in accordance with ASME Boiler and Pressure Vessel Code for Unfired Vessels.
- B. Stamped for 125 psi design pressure with tangential inlet and outlet connections.
- C. Internal perforated stainless steel air collector tube and blowdown connection.

2.14 PRESSURE REDUCING VALVE (CLOSED HYDRONIC SYSTEM FEED)

- A. Description: Self-filling type with low inlet pressure check valve, removable strainer, adjustable range, and set point as indicated on the Drawings.
- B. Construction:
 - 1. Iron body for steel piping installation, brass body for copper piping installation.
 - 2. Brass working parts.
- C. Size: 3/4-inch unless shown otherwise.

2.15 WATER RELIEF VALVES

- A. Bronze or steel body, stainless steel or bronze, pressure settings to 160 psi at 250 degrees F, conforming to Section IV of ASME Code, size per manufacturer's recommendations based on Code, setting as indicated; Kunkle Model 537.

2.16 STRAINERS

- A. Wye Pattern:
 - 1. Bronze: Bronze body, 250 psi, 1/16-inch perforated type 304 stainless screen.
 - 2. Ductile Iron: Ductile iron body, 300 psi, 1/16 or 1/8-inch 304 stainless steel screen.
 - 3. Cast Iron: Cast iron body, 125 psi, 1/16-inch perforated type 304 stainless screen.
 - 4. Cast Iron, High Pressure: Cast iron body, 250 psi, 1/16-inch perforated type 304 stainless screen.
- B. Basket Pattern: Semi-steel body, 125 psi WOG, flanged, 1/8-inch perforated type 304 stainless steel screen, closed bottom basket, clamped, or bolted cover.

2.17 SUCTION DIFFUSERS

- A. Description:
 - 1. Angle type body with inlet straightening vanes and combination orifice cylinder-diffuser-strainer with 3/16-inch diameter openings.
 - 2. Provide inlet vane length equal to 2-1/2 times pump connection diameter.
 - 3. Provide adjustable support foot to carry the weight of suction piping, drain plug, and pressure gauge tap.
- B. Construction:
 - 1. Cast iron body rated for 175 psig operating pressure at 300 degrees F.
 - 2. Provide steel inlet vanes on closed systems, stainless steel on open systems and domestic water systems.
 - 3. Provide steel orifice cylinders on closed systems, stainless steel on open systems and domestic water systems.

4. Provide bronze mesh start-up strainers on closed systems and domestic water systems, none on open systems.
- C. Selection:
1. Outlet Size: Match pump inlet size.
 2. Inlet Size:
 - a. Match pipe size upstream.
 - b. Maximum of 2 psi drop without start-up strainer.

PART 3 EXECUTION

3.1 INSTALLATION

- A. Provide valves at connections to equipment where shown or required for equipment isolation.
- B. Install valves and strainers in accessible locations and same size as connected piping (not the size of the equipment connection), except balancing valves sized by contractor to properly balance the flow.
- C. Provide separate support for valves where necessary.
- D. Provide drain valves in low points in the piping system, at coils and equipment, and as indicated.

3.2 APPLIED LOCATIONS HVAC VALVES

- A. Piping 2-inches and Smaller:

System	Valve Types				
	Gate	Globe	Swing Check	Ball	Butterfly
Chilled Water	Not Allowed	Bronze	Bronze	Bronze	Not Allowed
Chemical Treatment	Not Allowed	Bronze	Bronze	Bronze	Not Allowed
Pumped Condensate	Bronze	Bronze	Bronze	Bronze	Not Allowed

- B. Piping 2-1/2-inches and Larger:

System	Valve Types				
	Gate	Globe	Check	Ball	Butterfly
Chilled Water	Iron	Iron	Iron, Swing	Not Allowed	Ductile Iron
Chemical Treatment	Iron	Iron	Iron, Swing	Not Allowed	Ductile Iron
Pump Discharge for Chilled Water,	Iron	Iron	Iron, Silent Check: Globe or Water Style, Swing with Lever and Weight or Lever and Spring	Not Allowed	Ductile Iron

- C. Calibrated y-pattern globe balancing valves 1/2-inch through 12-inches, on water coils and in piping systems in accordance with manufacturer's recommendations.
- D. Automatic flow control valves on water coils and in piping systems in accordance with manufacturer's recommendations to automatically balance water flow in piping loops as indicated.
- E. Provide gauge cock for pressure gauges.

- F. Provide gate valves with pressure type packing glands for heating water boiler shutoff applications. Meet requirements of ASME Boiler and Pressure Vessel Code, Section IV, Article 7 for Stop Valves.

3.3 VALVE IDENTIFICATION

- A. General: Identify valves to indicate their function and system served.
- B. See Section 23 05 53, Identification for HVAC Piping and Equipment.

3.4 CHAIN OPERATORS

- A. Install valves in equipment rooms or fan rooms used for equipment or coil isolation and more than 8 feet above floor with stem horizontal and equipped with chain wheels and chains extending to 6-feet above floor.

3.5 INSTALLATION

- A. Manual Air Vents:
 - 1. Install at high points where automatic air vents are not used, where noted, and where required for proper venting of system.
 - 2. Install in accordance with manufacturer's recommendations.
- B. Automatic Air Vents:
 - 1. Install automatic air vents at high points where air can collect in water systems where indicated. Route drain lines from vent to nearest floor drain.
 - 2. Install 3/4-inch globe shut-off valve ahead of air vent. Install ball valve where bucket drainage is required.
- C. Grooved Mechanical Pipe Valve End Connections:
 - 1. Refer to Section 23 21 13, Pipe and Pipe Fittings HVAC for allowed service installations.
 - 2. Install in accordance with the manufacturer's published installation instructions.
 - 3. Mold and produce gaskets by the coupling manufacturer, and suitable for the intended service.
 - 4. The coupling manufacturer's factory trained representative:
 - a. Provide on-site training for the contractor's field personnel in the use of grooving tools and installation of grooved joint products.
 - b. Periodically visit the project site to ensure best practices in grooved installation are being followed.
 - c. A distributor's representative is not considered qualified to conduct the training or field visits.
- D. Test Plugs: Install where indicated and in accordance with the manufacturer's recommendations.
- E. Coil Connectors:
 - 1. Make connections in accordance with Section 23 21 13, Pipe and Pipe Fittings HVAC.
- F. Expansion Tanks:
 - 1. Support with steel rods and brackets from structure or from structural steel stand as required.
 - 2. Pipe valve drain to over floor drain.
- G. Water Buffer Tank:
 - 1. Install as shown on Drawings and in accordance with the manufacturer's recommendations.
 - 2. Insulate per Section 23 07 00, Insulation for HVAC.

3. Pipe valve drain to over floor drain.
- H. Air Separator:
1. Install as shown on Drawings and in accordance with the manufacturer's recommendations.
 2. Suspend from structure with steel rods or brackets or support from steel stand as required.
 3. Bleed system air at start-up according to manufacturer's recommendations.
- I. Water Relief Valves:
1. Install where indicated, and in accordance with manufacturer's instructions.
 2. Pipe discharge to nearest floor drain using Schedule 40 steel pipe.
- J. Strainer:
1. Provide valved blow off for each strainer of same size as plugs with maximum size of 1-1/2 inches.
 2. Pipe blow off full size and terminate over floor drains except finned tube, reheat coils, fan coils, terminal units, and unit heaters.
 3. Applied Locations HVAC:
 - a. Cast iron wye, chilled, heating, and heat recovery water, low pressure steam, low pressure condensate.
 - b. Bronze wye, in piping 2-inch and smaller, medium, and high pressure steam and condensate.
 - c. Cast iron, high pressure wye, in piping 2-1/2-inch and larger, medium, and high pressure steam and condensate.
 - d. Basket, in piping 2-1/2-inch and larger, condenser water inlet to pumps.
- K. Suction Diffusers:
1. Install on inlets of pumps where indicated in accordance with manufacturer's recommendations.
 2. Support suction diffuser and piping from same surface as pump base is supported unless shown otherwise. Adjust foot so that pump inlet does not carry piping weight.
 3. Pipe pressure gauges to gauge port, and blow down to drain with ball shut-off valve.
 4. After operating pumps for seven days, clean strainer and remove start-up strainer.

END OF SECTION

SECTION 23 05 29
HANGERS AND SUPPORTS FOR HVAC

PART 1 GENERAL

1.1 RELATED DOCUMENTS

- A. Drawings and general provisions of the Contract, including General and Supplementary Conditions and Division 01, General Requirements Specification Sections, apply to this Section.
- B. The provisions of Division 23, Heating, Ventilation and Air Conditioning (HVAC) Section 23 05 00, Common Work Results for HVAC, apply to work specified in this Section.

1.2 SUMMARY

- A. This Section includes Design-Build work.
- B. This Section includes:
 - 1. Supports
 - 2. Anchors
 - 3. Pipe Rollers
 - 4. Insulation Protection Shields
 - 5. Insulation Protection Saddles
 - 6. Building Attachments
 - 7. Roof Curbs

1.3 RELATED SECTIONS

- A. Division 01, General Requirements
- B. Division 23, Heating, Ventilating, and Air Conditioning (HVAC)
- C. Section 23 05 48, Vibration and Seismic Controls for HVAC Piping and Equipment
- D. Section 23 07 00, Insulation for HVAC
- E. Section 23 21 13, Pipe and Pipe Fittings HVAC

1.4 QUALITY ASSURANCE

- A. Provide pipe and equipment hangers and supports in accordance with the following:
 - 1. Design supports, anchorages, and seismic restraints for equipment, and supports and seismic restraints for conduit, piping, and ductwork when not shown on the Drawings.
 - 2. Hangers, supports and sway braces to be fabricated in accordance with ANSI B31.1 and MSS SP-58 and SP-89.
 - 3. Use components for intended design purpose only. Do not use for rigging or erection purposes.
 - 4. Seismic restraints and anchorages shall resist seismic forces as specified in the state and local code or by the authority having jurisdiction for the seismic zone in which the project is constructed.
 - 5. Connections to structural framing are not to introduce twisting, torsion, or lateral bending in the framing members. Provide supplementary steel as required.
 - 6. Seismic Restraints:
 - a. Shall not introduce stresses in the piping caused by thermal expansion or contraction.
 - b. Shall not exceed forces or design limits of the piping per ASME B31.9.
 - c. Provide in accordance with the latest edition of the SMACNA, "Seismic Restraint Manual Guidelines for Mechanical Systems" for the Seismic Hazard Level corresponding to the seismic zone in which the project is constructed.

- d. Provide in accordance with the local applicable codes.
- e. Follow provisions described in Section 23 05 48, Vibration and Seismic Controls for HVAC Piping and Equipment.
- 7. Piping Connections to Equipment:
 - a. Shall not introduce twisting, torsion, or lateral forces or moments on the equipment.
 - b. Shall be supported and isolated in a manner not to exceed the equipment's point of connection load limitations.
- B. Engineered Support Systems: Provide design services for the following support systems:
 - 1. Supports and seismic restraints for suspended piping, ductwork, and equipment.
 - 2. Support frames such as pipe racks or stanchions for piping, ductwork, and equipment which provide support from below.
 - 3. Equipment, ductwork, and piping support frame anchorage to supporting slab or structure.

1.5 SUBMITTALS

- A. Submit the following:
 - 1. Shop Drawings of contractor fabricated support structures.
 - 2. Structural Details and Calculations:
 - a. Submit structural details and calculations substantiating that building structure, anchorages, and fabricated steel braces can safely withstand maximum calculated loads.
 - b. Details and calculations to bear the seal of a professional engineer registered in the state having jurisdiction.
 - 3. No other submittals required under this section.

PART 2 PRODUCTS

2.1 MANUFACTURERS

- A. Supports:
 - 1. Unistrut
 - 2. Superstrut
 - 3. Powerstrut
 - 4. Kinline
 - 5. B-Line Systems
 - 6. AnvilStrut
- B. Pipe Hangers:
 - 1. Anvil
 - 2. Superstrut
 - 3. B-Line Systems
 - 4. Tolco
 - 5. ERICO
 - 6. Pipe Shields Inc.
 - 7. Rilco
- C. Pipe Rollers
 - 1. Anvil
 - 2. Super Strut

3. B-Line Systems
4. Tolco
5. ERICO
- D. Insulation Protection Shields
 1. Anvil
 2. Super Strut
 3. B-Line Systems
 4. Tolco
 5. ERICO
- E. Insulation Protection Saddles
 1. Anvil
 2. Super Strut
 3. B-Line Systems
 4. Tolco
 5. ERICO
- F. Pipe Guides
 1. Anvil
 2. B-Line Systems
 3. Pipe Shields Inc.
 4. Rilco
 5. Hyspan
- G. Pipe Anchors
 1. Anvil
 2. B-Line Systems
 3. Pipe Shields Inc.
 4. Rilco
- H. Building Attachments
 1. Anvil
 2. Elcen
 3. Superstrut
 4. B-Line Systems
 5. Tolco
 6. ERICO
- I. Roof Mounted Equipment Support
 1. Thybar
 2. Greenheck
 3. Twin City
- J. Roof Curbs
 1. Thybar
 2. Greenheck
 3. Twin City

2.2 SUPPORTS

- A. Fabricate support members from welded standard structural shapes, pipe, and plate to carry the necessary rollers, hangers, and accessories as required. Support piping less than 4-inch pipe size from or by prefabricated roll-formed channels with necessary accessories to adequately support piping system.
- B. Supports and Accessories: Preformed roll-formed channels and accessories with matching compatible accessories as shown, as specified, and as required.
- C. Dissimilar Metal Protection: Hydra-Zorb cushions or Cush-a-strip.
- D. Clamps: Super Strut Series 700 through 702 or AnvilStrut Series 1000 through 1200.

2.3 PIPE HANGERS

- A. Uninsulated Horizontal Copper Piping:
 - 1. 2-inch and Smaller: Anvil CT-65, CT-69.
 - 2. Larger than 2-inch:
 - a. Anvil 260 field or factory copper plated, plastic coated or other recognized industry methods.
 - b. Electricians' tape is unacceptable.
- B. Insulated Horizontal Copper Pipe with Hangers Outside of Insulation:
 - 1. 2-inch and Smaller: Anvil 65, 104 or 260.
 - 2. Larger than 2-inch: Anvil 260.
- C. Other Uninsulated Horizontal Pipe:
 - 1. 2-inch and Smaller: Anvil 65, 104 or 260.
 - 2. Larger than 2-inch: Anvil 260.
- D. Other Insulated Horizontal Pipe with Hangers Outside of Insulation:
 - 1. 2-inch and Smaller: Anvil 65, 104 or 260.
 - 2. Larger than 2-inch: Anvil 260.
- E. Riser Clamps Copper Pipe:
 - 1. 4-inch and Smaller: Anvil CT-121, CT-261.
 - 2. Larger than 4-inch: Anvil 261.
- F. Riser Clamps Other Piping: Anvil 261.

2.4 PIPE ROLLERS

- A. Cast Iron roll and sockets, steel roll rod.
 - 1. Anvil 171, 175, 177, 178, 181, or 274 as required.
 - 2. Size for pipe plus insulation for insulated pipe.

2.5 INSULATION PROTECTION SHIELDS

- A. Galvanized carbon steel.
 - 1. Anvil 167.

2.6 INSULATION PROTECTION SADDLES

- A. Carbon steel.
 - 1. Anvil 160 series.
 - 2. Saddles for copper pipe: Factory copper plated.

2.7 PIPE GUIDES

- A. Spider type alignment guide.
 - 1. Anvil 255, 256, 257 & 436

2. Steel Piping:
 - a. Carbon steel housing
 - b. Carbon steel spider clamp
3. Copper Piping:
 - a. Carbon steel housing
 - b. Factory copper plated steel spider clamp

2.8 PIPE ANCHORS

- A. Uninsulated Pipe
 1. Pipe Shields Inc. C1000
- B. Insulated Pipe
 1. Pipe Shields Inc. C3000 through C4300 series
- C. Pipe Stanchions
 1. Anvil 62

2.9 BUILDING ATTACHMENTS

- A. Beam Hangers:
 1. On piping 6-inch and smaller: Anvil 86 with retaining clip Fig. 89.
 2. On piping larger than 6-inch: Anvil 228, or 292.
- B. Inserts:
 1. Anvil 152 malleable iron or 281 steel inserts.
 2. Inserts sized for required rod to support load being carried.
- C. Expansion Plugs: Similar and equal to Phillips "red-head" self-drilling flush shell selected for safety factor of 4.
- D. Powder actuated fasteners with silencers as approved by Engineer.

2.10 ROOF CURBS

- A. Continuous welded aluminum or galvanized steel construction.
- B. Pressure treated wood nailer strip mechanically fastened with corrosion resistant fasteners.
- C. Engineered to support gravity and seismic loads of entire unit.
- D. Suitable for use on insulated or non-insulated roof decks.
- E. Account for roof slope and roof insulation thickness to provide level mounting service for equipment.
- F. Curb height no less than 24 inches from roof membrane.
- G. Provide minimum 1-1/2 inch thick 3 pounds per cubic foot density rigid fiberglass insulation with encapsulated top and bottom.

PART 3 EXECUTION

3.1 HANGERS AND SUPPORTS

- A. General:
 1. Install support systems as detailed and in accordance with manufacturer's recommendations. Provide pipe racks, pipe stands, trapeze hangers, etc., as required, and as detailed on the Drawings.
 2. Provide adjustable hangers for pipes complete with inserts, adjusters, bolts, nuts, swivels, all-thread rods, etc., except where specified otherwise.

3. Arrange for grouping of parallel runs of horizontal piping to be supported together on trapeze type hangers where possible. Where piping of various sizes is to be supported together by trapeze hangers, space hangers for smallest pipe size or install intermediate supports for smaller diameter pipe. Do not use wire or perforated metal to support piping and do not support piping from other piping.
 4. Except as otherwise indicated for exposed continuous pipe runs, install hangers, and supports of same type and style as installed for adjacent similar piping.
 5. Support piping within 2-feet of each change of direction on both sides of fitting.
- B. Insulated Piping Systems:
1. Refer to Section 23 07 00, Insulation for HVAC for insulation requirements.
 2. Insulated Piping Systems with Vapor Barrier Insulation:
 - a. Install hangers outside of insulation.
 - b. On piping 1-1/2-inch and larger, provide insulation protection shields at each support location.
- C. Vertical Piping:
1. Support Spacing: Provide support at minimum spacing in accordance with state and local codes.
 2. Support with U-clamps fastened to wall to hold piping away from wall unless otherwise approved.
 3. Provide mid-story vertical guide support where floor to floor distances exceed spacing as required by state and local codes. Riser clamps on steel pipe to be directly welded to pipe. Riser clamps on copper pipe to be installed directly under fitting.
 4. Risers that are not subject to thermal change to be supported at each floor of penetration.
 5. Risers that are subject to thermal change require engineered supports. Size supports to carry forces exerted by piping system when in operation. Riser supports follow the provisions described in Section 23 05 48, Vibration and Seismic Controls for HVAC Piping and Equipment.
- D. Horizontal Piping:
1. Trapeze Hangers:
 - a. Multiple pipe runs where indicated supported on channels with rust resistant finish.
 - b. Provide necessary rods and supporting steel.
 2. Support Spacing:
 - a. Provide support at maximum spacing in accordance with state and local codes and any applicable manufacturer requirements.
 - b. Support piping within 2-feet of each change in direction.
 - c. Provide piping with acoustical lagging wrap supported a maximum of 5-feet on center. Install hangers outside of acoustical lagging.
- E. Building Attachments:
1. Fastening or attaching to steel deck (without concrete fill) is prohibited. It will be necessary to support piping from structural members, beams, joists, or provide intermediate angle iron supporting members between joists. Supports may be attached to concrete filled steel deck with load limitations shown on the structural drawings or otherwise obtained from the structural engineer.

2. Provide horizontal bracing on horizontal runs 1-1/2-inch and larger and exceeding 50-feet in length at 75-foot intervals and as required to provide stabilized piping systems.
3. Provide additional structural steel angles, channels, or other members required to support piping where structures do not occur as required for proper support.
4. Arrange supports to prevent eccentric loading of joists and joist girders. Locate supports at joist panel points.

F. Roof Curbs:

1. Select appropriate model for insulated or uninsulated roof deck.
2. Install per manufacturer's instructions.
3. Account for roof slope to provide level mounting service for equipment.
4. Coordinate dimensions with chilled water piping.

END OF SECTION

SECTION 23 05 48

VIBRATION AND SEISMIC CONTROLS FOR HVAC PIPING AND EQUIPMENT

PART 1 GENERAL

1.1 RELATED DOCUMENTS

- A. Drawings and general provisions of the Contract, including General and Supplementary Conditions and Division 01, General Requirements Specification Sections, apply to this Section.
- B. The provisions of Division 23, Heating, Ventilation and Air Conditioning (HVAC) Section 23 05 00, Common Work Results for HVAC, apply to work specified in this Section.

1.2 SUMMARY

- A. This Section includes:
 - 1. Base with Springs
 - 2. Inertia Base
 - 3. Isolating Spring Hangers
 - 4. Isolating Sleeves
 - 5. Seismic Restraints
 - 6. Flexible Sphere Connector
- B. Isolation of mechanical equipment as indicated on the Drawings and specified herein.
- C. Seismic restraint of equipment, piping, and ductwork.

1.3 RELATED SECTIONS:

- A. Division 01, General Requirements
- B. Division 23, Heating, Ventilating, and Air Conditioning (HVAC)
- C. Section 23 05 18, HVAC Expansion Compensation
- D. Section 23 05 29, Hangers, Supports and Anchors for HVAC
- E. Section 23 31 01, HVAC Ducts and Casing-Low Pressure

1.4 QUALITY ASSURANCE

- A. Single manufacturer select and furnish isolation required, except packaged equipment with integral isolators meeting all the isolation and seismic requirements of this Specification.
- B. System of vibration isolators and seismic controls designed, detailed, and bear the seal of a professional engineer registered in the State having jurisdiction.
- C. Isolation performance requirements are indicated in the specifications. Deflections indicated are nominal static deflections for specific equipment supported.
- D. Isolator Stability and Rated Capacity:
 - 1. Spring diameters not less than 0.8 of the compressed height of the spring at rated load.
 - 2. Springs have a minimum additional travel to solid equal to 50 percent of the rated deflection.
- E. Seismic Restraints:
 - 1. Restraint of equipment, piping, and ductwork to be in accordance with the current state and local Building Code.
 - 2. Calculations in accordance with current state and local Building Code.

1.5 SUBMITTALS

- A. Submit the following:
 - 1. Submit Shop Drawings showing complete details of construction for steel and concrete bases including:
 - a. Equipment mounting holes.
 - b. Dimensions
 - c. Isolation selected for each support point.
 - d. Details of mounting brackets for isolator.
 - e. Weight distribution for each isolator.
 - f. Code number assigned to each isolator.
 - 2. Submit product data and calculation sheets for isolators, showing:
 - a. Size, type, load rating, and rated deflection of each required isolator.
 - b. Percent of vibration transmitted based on the lowest disturbing frequency of the equipment.
 - 3. Structural Details and Calculations substantiating that building structure, anchorages, and fabricated steel braces can safely withstand maximum calculated loads stamped and signed by a registered structural engineer.
 - 4. Installation report as specified in PART 3 of this Section.
 - 5. Operation and maintenance data.

1.6 EQUIPMENT VIBRATION ISOLATION

- A. Provide a balanced set of vibration isolators for each piece of equipment listed in the Equipment Schedules.
- B. Isolation work to include, but not necessarily be limited to, the following:
 - 1. Isolation support of motor-driven equipment.
 - 2. Inertia base frames in conjunction with isolation.
 - 3. Isolation support of air-handling housings.
 - 4. Isolation support of piping, piping risers, and ductwork.
 - 5. Penetration isolation of pipework, ductwork, and conduits through walls, floors, or ceilings.
 - 6. Flexible connections of ductwork and piping to equipment.
- C. Each piece of rotating equipment must meet a reasonable criterion for maximum vibration levels at each bearing, while in operation. The criteria for varying operating speeds are given as follows:
 - 1. Rotating equipment operating at peak vibration velocities must not exceed 0.08-inch/second.
 - 2. If it is discovered that the operating vibration velocities exceed this criteria, the equipment repaired or replaced at no expense to the owner until approval of the equipment is given by the Engineer.
- D. Provide components or materials not specially mentioned herein, but necessary to the proper vibration isolation of the equipment.

1.7 CONTRACTOR RESPONSIBILITY

- A. Vibration isolation devices, including auxiliary steel bases and pouring forms, design and furnish by a single manufacturer or supplier.

- B. Adequately restrain all equipment, piping, and ductwork to resist seismic forces. Design and select restraint devices to meet seismic requirements as defined in the latest issue of the International Building Code under Earthquake Loads and applicable state and local codes.
- C. Have the following responsibilities:
 - 1. Selection, installation, adjustment, and performance of vibration isolators which will meet the requirements given on the plans or in the Specifications.
 - 2. Provide Engineering drawings, details, supervision, and instruction to assure proper installation and performance.
 - 3. Provide whatever assistance necessary to ensure correct installation and adjustment of the isolators.

PART 2 PRODUCTS

2.1 MANUFACTURERS

- A. Type 5 – Base with Springs:
 - 1. Mason WFSL
 - 2. Kinetics Noise Control
 - 3. Vibrex
- B. Type 6 – Inertia Base:
 - 1. Mason BMK or KSL
 - 2. Kinetics Noise Control
 - 3. Vibrex
- C. Type 7 – Isolating Spring Hangers:
 - 1. Mason 30N, similar Amber-Booth
 - 2. Kinetics Noise Control
 - 3. Vibrex
- D. Isolating Sleeves:
 - 1. Potter-Roemer PR isolators
 - 2. Grinnell Semco Trisolators
- E. Flexible Sphere Connector:
 - 1. Mason Type SFU, SFDEJ, or SFEJ

2.2 TYPE 5 - BASE WITH SPRINGS

- A. Steel base with wide flange beams and springs.
- B. Provide minimum clearance of 1-inch.
- C. Depth of base equal to 10 percent of the span between supports, 6-inch minimum.
- D. Provide external height saving brackets.

2.3 TYPE 6 – INERTIA BASE

- A. Steel Inertia Base with 1/2-inch square bar reinforcing, for field grout.
- B. Provide minimum clearance of 1-inch.
- C. Bases must be sized to fit stanchions for pump elbows or suction diffusers.
- D. Depth of base equal to 8 percent of the span between supports, 6-inch minimum.
- E. Provide integral height saving brackets and steel templates with anchor bolts sleeves.

2.4 TYPE 7 - ISOLATING SPRING HANGERS

- A. Combination rubber-in shear and steel spring isolators installed on the hanger rods.

- B. Isolators shall have the proper deflection to allow the piping to deflect as a unit with the equipment isolators.
- C. Neoprene element and the cup shall have neoprene bushing bushings projecting through the steel box.
- D. Hangers designed for 30 degree angular movement.
- E. Minimum Deflection: 1-inch

2.5 ISOLATING SLEEVES

- A. Provide for piping through walls and floors of penthouses and chiller room. Size for piping as required.

2.6 SEISMIC RESTRAINTS

- A. General Requirements:
 - 1. Provided for equipment, piping and ductwork, both supported and suspended.
 - 2. Bracing of piping shall be in accordance with state and local code requirements and ASCE 7 Seismic Design Requirements for Nonstructural Components, whichever is most stringent.
 - 3. Bracing of ductwork shall be in accordance with the state and local code requirements, ASCE 7 Seismic Design Requirements for Nonstructural Components, and with the provisions set forth in the SMACNA seismic restraint manual.
 - 4. The structural requirements for the restraints, including their attachment to the building structure, shall be reviewed and approved by the Structural Engineer.
 - 5. Attachments to supported or suspended equipment must be coordinated with the equipment manufacturer.
- B. Supported Equipment:
 - 1. All-directional Seismic Rubbers: Interlocking steel members restrained by a one-piece molded neoprene bushing of bridge bearing neoprene.
 - 2. Replaceable bushing and minimum of 1/4-inch thick. Rated loadings not to exceed 1000 psi.
 - 3. An air gap of 1/4-inch shall be incorporated in the snubber design in all directions before contact is made between the rigid and resilient surfaces.
 - 4. Snubber End Caps:
 - a. Removable to allow inspection of internal clearances.
 - b. Rotated neoprene bushings be rotated to ensure no short circuits exist before systems are activated.
 - 5. Snubber: Mason Industries, Inc. Type Z-1225
- C. Bracing of Pipes:
 - 1. Provide seismic bracing of piping as detailed below to meet the building code requirements:
 - a. Exception: Piping suspended by individual hangers need not be braced where the following criteria are met.
 - 1) Distance between the top of the pipe to the bottom of the support structure is 12-inches or less.
 - 2) Seismic braces are not required on high deformability piping when the $I_p=1.0$ and provisions are made to avoid impact with larger pipe or mechanical components or to protect the pipe in the event of such impact and the nominal pipe size is 3-inch diameter or less.

- 3) Seismic braces are not required on high deformability piping when the $I_p=1.5$ and provisions are made to avoid impact with larger pipe or mechanical components or to protect the pipe in the event of such impact and the nominal pipe size is 1-inch diameter or less.
 2. Seismic braces for pipes on trapeze hangers may be used.
 3. Provide flexibility in joints where pipes pass through building seismic joints or expansion joints, or where pipes connect to equipment.
 4. Cast iron pipe of all types, glass pipe, and any other pipe joined with a shield and clamp assembly, where the top of the pipe is 12-inches or more from the supporting structure, shall be braced on each side of a change in direction of 90 degrees or more. Riser joints on unsupported sections of piping shall be braced or stabilized between floors.
 5. Vertical risers shall be laterally supported with a riser clamp at each floor. For buildings greater than six stories high or for piping subject to thermal change all risers shall be engineered individually.
- D. Suspended Equipment and Piping and Ductwork:
1. Seismic cable restraints shall consist of galvanized steel aircraft cables sized to resist seismic loads with a minimum safety factor of two and arranged to provide all-directional restraint.
 2. Cable must be pre-stretched to achieve a certified minimum modulus of elasticity. Cable end connections shall be steel assemblies that swivel to final installation angle and utilize two clamping bolts to provide proper cable engagement.
 3. Cable assemblies shall be type SCB at the ceiling and at the clevis bolt, SCBH between the hanger rod and the clevis or SCBV if clamped to a beam, all as manufactured by Mason Industries, Inc.
 4. Steel angles or strut, sized to prevent buckling, shall be clamped to pipe or equipment rods utilizing a minimum of three ductile iron clamps at each restraint location when required. Welding of a minimum of three ductile iron clamps at each restraint location when required. Welding of support rods is not acceptable. Rod clamp assemblies shall be type SRC or UCC as manufactured by Mason Industries, Inc.
 5. Pipe clevis cross-bolt braces are required in all restraint locations. They shall be special purpose preformed channels deep enough to be held in place by bolts passing over the cross bolt. Clevis cross brace shall be type CCB as manufactured by Mason Industries, Inc.

2.7 FLEXIBLE SPHERE CONNECTOR

- A. Flexible EPDM pipe connectors shall be manufactured of multiple plies of Kevlar tire cord fabric and EPDM; both molded and cured in hydraulic rubber presses. No steel wire or rings shall be used as pressure reinforcement.
- B. Connectors up to and including 2-inch diameter may have a single sphere and threaded ends. Connectors 2-1/2-inch and larger shall be manufactured with twin spheres up to 12-inches and a single sphere on larger sizes and floating steel flanges recessed to lock the connectors raised face EPDM flanges.
- C. Connectors shall be rated a minimum of 150 psi at 220 degrees F. Connections shall be pre-extended as recommended by the manufacturer to prevent additional elongation under pressure.
- D. Provide expansion joint control rods and install per the manufacturers installation recommendations.

PART 3 EXECUTION

3.1 GENERAL

- A. Do not install any equipment or pipe which makes rigid contact with the building.
- B. The installation or use of vibration isolators must not cause any change of position of equipment or piping which would result in stresses in piping connections or misalignment of shafts or bearings. In order to meet this objective, equipment and piping shall be maintained in a rigid position during installation. The load shall not be transferred to the isolator until the installation is complete and under full operational load.
- C. Correct, at no additional cost, all installations which are defective in workmanship or materials.

3.2 PREPARATION

- A. Treat all isolators, including springs, hardware, and housing, with a corrosion protective coating of epoxy powder or electro galvanizing.
- B. Coat steel frames exposed to weather with a rustproof metal primer.
- C. Provide hot dipped galvanizing on steel frames as indicated on the plans for corrosion protection in severe conditions.

3.3 INSTALLATION

- A. General:
 - 1. Install isolation where indicated on the Drawings by type and location and where indicated below.
 - 2. The assigned code number shall be marked on the isolators and bases to assure placement in the proper location.
 - 3. Anchor isolator seismic housing baseplate to floor.
 - 4. Rubber grommets and washers shall be provided to isolate the bolt from the building structure. Under no circumstances shall the isolation efficiency be destroyed when bolting the isolators to the building structure.
- B. Type 5 – Base with Springs:
 - 1. Service:
 - a. Chillers
 - b.
- C. Type 6 – Inertia Base with Springs:
 - 1. Service:
 - a. Centrifugal Pumps:
 - 1) Fill with concrete to provide base weight equal to 2 times supported weight, including equipment, piping, and fluid.
 - 2) Support heels of pump suction and discharge elbows from base.
 - 3) Secure pump and heel supports with inserts and grout.
- D. Type 7 – Isolating Spring Hangers:
 - 1. Service:
 - a. Fan Coil Units
- E. Flexible Connectors:
 - 1. Mechanical Couplings: Provide three or more flexible couplings as vibration isolation as indicated on the drawings and for the following services: Chilled Water

3.4 SEISMIC RESTRAINTS

A. General:

1. Install and adjust seismic restraints so that the equipment, piping, and ductwork support is not degraded by the restraints.
2. Restraints must not short circuit vibration isolation systems or transmit objectionable vibration or noise.

B. Supported Equipment:

1. Each vibration isolation frame for supported equipment shall have a minimum of four seismic snubbers mounted as close as possible to the vibration isolators and/or the frame extremities.
2. Care must be taken so that the 1/4-inch air gap in the seismic restraint snubber is preserved on all sides in order that the vibration isolation potential of the isolator is not compromised. This requires that the final snubber adjustment be completed after the vibration isolators are properly installed and the installation approved.

C. Bracing of Pipes:

1. Branch lines may not be used to brace main lines.
2. Transverse bracing shall be at 40-feet maximum, except where a lesser spacing is indicated in the SMACNA Seismic Restraint Manual for bracing of pipes.
3. Longitudinal bracing shall be at 80-feet maximum except where a lesser spacing is indicated in the tables. In pipes where thermal expansion is a consideration, an anchor point may be used as the specified longitudinal brace provided that it has a capacity to resist both the seismic load and the additional force induced by expansion and contraction.
4. Fuel oil, gas, cast iron pipe of all types, glass pipe and any other pipes joined with four band shield and clamp assembly shall be braced at 1/2 the spacings shown above.
5. A rigid piping system shall not be braced to dissimilar parts of the building or to two dissimilar building systems that may respond differently during an earthquake.
6. Transverse bracing for one pipe section may also act as longitudinal bracing for a pipe section of the same size connected perpendicular to it if the bracing is installed within 24-inches of the elbow or tee.
7. Branch lines may not be used to restrain main lines.
8. Where thermal expansion is a consideration, guides and anchors may be used as transverse and longitudinal restraints provided they have a capacity equal to or greater than the restraint loads in addition to the loads induced by expansion or contraction.
9. Subject to confirmation by field inspection, seismic bracing is not required on piping when the piping is supported by rod hangers and the hangers in the entire run are 12-inches or less in length from the top of the pipe to the supporting structure, hangers are detailed to avoid bending of the hangers and their attachments and provisions are made for piping to accommodate expected deflections.

D. Suspended Equipment, Piping, and Ductwork Cable Method:

1. The cables shall be adjusted to a degree of slackness approved by the Structural Engineer.
2. The uplift and downward restraint nuts and Mason type RW neoprene covered steel rebound washers for the Type 6 hangers adjusted so there is a maximum 1/4-inch clearance.
3. C-clamps for attachment to the bottom of I-beams must incorporate a restraining strap.

3.5 FIELD QUALITY CONTROL

- A. Installation Report: Isolation manufacturer's representative shall confirm that all isolation is installed correctly and submit report stating that isolators are installed as shown on Shop Drawings, isolators are free to work properly, and that installed deflections are as scheduled and as specified.

END OF SECTION

SECTION 23 05 53
IDENTIFICATION FOR HVAC PIPING AND EQUIPMENT

PART 1 GENERAL

1.1 SUMMARY

- A. This Section includes:
 - 1. Valve Identification
 - 2. Piping Markers
 - 3. Equipment Identification
 - 4. Concealed Equipment Identification

1.2 RELATED SECTIONS

- A. Division 01, General Requirements
- B. Division 23, Heating, Ventilating, and Air Conditioning (HVAC)

1.3 SUBMITTALS

- A. Submit the following:
 - 1. Valve Tag Directory: Submit for approval prior to fabrication of valve tags.
 - 2. Equipment Nameplate Directory: Submit for approval prior to fabrication.
 - 3. Operating and Maintenance Data: Include a copy of valve tag and equipment nameplate directories in each set of Operating and Maintenance manuals.

PART 2 PRODUCTS

2.1 MANUFACTURERS

- A. Piping Markers:
 - 1. W.H. Brady
 - 2. Seton
 - 3. Marking Systems, Inc. (MSI)
 - 4. Other Manufacturers: Submit substitution request.
- B. Concealed Equipment Identification:
 - 1. W.H. Brady
 - 2. Seton
 - 3. Other Manufacturers: Submit substitution request.

2.2 VALVE IDENTIFICATION

- A. Valve Tags:
 - 1. General: Identify valves with metal tags, legends to be stamped or embossed. Indicate the function of the valve and its normal operating position; i.e.,

56 HW	(NUMBER AND CONTENT OF PIPE)
ISOLATION	(VALVE FUNCTION)
NO	(NORMAL OPERATION POSITION)
 - 2. Size: Valve tags 2-inch diameter with 1/4-inch high letters.
 - 3. Material: Use 0.04-inch brass tags.
 - 4. Automatic Valves and Regulating Valves:
 - a. Use 1/16-inch thick laminated 3-ply plastic, center ply white, outer ply red, lamicaid, or equal.
 - b. Form letters by exposing center ply.

5. Buildings Systems: Contact the Owner for coordination with existing building tagging system and supplementary information required for any specific system before valve tagging begins.
- B. Valve Tag Directory:
1. Tag Number
 2. Location
 3. Exposed or Concealed
 4. Service
 5. Valve Size
 6. Valve Manufacturer
 7. Valve Model Number
 8. Normal Operating Position of Valve

2.3 PIPING MARKERS

- A. Label pipes with all-vinyl, self-sticking labels or letters.
- B. For pipe covering sizes up to and including 3/4-inch outside diameter, select labels with 1/2-inch letters.
- C. For sizes from 3/4 to 2-inch outside diameter, 3/4-inch letters, above 2-inches outside diameter, 2-inch letters.
- D. Identify pipe markers and color coded as follows with black directional arrows.

HVAC SERVICE	PIPE MARKER *	BACKGROUND COLOR
CHILLED WATER	CHILLED WATER SUPPLY	GREEN
	CHILLED WATER RETURN	GREEN
* Directional arrow applied adjacent to pipe marker indicating direction of flow.		

2.4 EQUIPMENT IDENTIFICATION

- A. Nameplates:
 1. Tag pumps, air handling supply units, fans, terminal units, converters, and miscellaneous items of mechanical equipment with engraved nameplates.
 2. 1/16-inch thick, 3-inch by 5-inch laminated 3-ply plastic, center ply white, outer ply black. Form letters by exposing center ply.
 3. Identify unit with equipment tag as shown on Drawings and area served.
- B. Equipment Nameplate Directory:
 1. List Pumps
 2. Terminal Units
 3. Other Equipment Nameplates
- C. Include Owner and Contractor furnished equipment.
- D. List the following on the nameplate:
 1. Designation
 2. Model Number
 3. Location of Equipment
 4. Area Served or Function
 5. Disconnect Location
 6. Normal Position of HOA Switch

PART 3 EXECUTION

3.1 VALVE IDENTIFICATION

- A. Valve Tags:
 - 1. Attach to valve with a brass chain.
 - 2. Valve tag numbers continuous throughout the building for each system.
 - 3. Obtain a list for each system involved from the Owner.
- B. Valve Tag Directory: Post final copy in Operation and Maintenance Manual.

3.2 PIPING MARKERS

- A. Unless recommendations of ANSI A13.1, 1981 are more stringent, apply labels or letters after completion of pipe cleaning, insulation, painting, or other similar work, as follows:
 - 1. Every 20-feet along continuous exposed lines.
 - 2. Every 10-feet along continuous concealed lines.
 - 3. Adjacent to each valve and stub out for future.
 - 4. Where pipe passes through a wall, into and out of concealed spaces.
 - 5. On each riser.
 - 6. On each leg of a T.
 - 7. Locate conspicuously where visible.
- B. Apply labels or letters to lower quarters of the pipe on horizontal runs where view is not obstructed or on the upper quarters when pipe is normally viewed from above.
- C. Apply arrow labels indicating direction of flow.
- D. Arrows the same color and sizes as identification labels.

3.3 EQUIPMENT IDENTIFICATION

- A. Nameplates: Attach to prominent area of equipment, either with sheet metal screws, brass chain, or contact cement as applicable.
- B. Nameplate Directory: Post final copy in Operation and Maintenance Manual.

END OF SECTION

SECTION 23 05 90
PRESSURE TESTING FOR HVAC SYSTEMS

PART 1 GENERAL

1.1 SUMMARY

- A. This Section includes:
 - 1. Pressure Testing of Piping Systems

1.2 RELATED SECTIONS

- A. Division 01, General Requirements
- B. Division 23, Heating, Ventilating, and Air Conditioning (HVAC)

1.3 QUALITY ASSURANCE

- A. Code Compliance: Perform required tests in the presence of the authority having jurisdiction.
- B. Owner Witness: Perform tests in the presence of the Owner's representative.
- C. Engineer Witness: The Engineer or Engineer's representative reserves the right to observe tests or selected tests to assure compliance with the specifications.
- D. Simultaneous Testing: Test observations by the authority having jurisdiction, the Owner's representative, and the Engineer's representative need not occur simultaneously.

1.4 SUBMITTALS

- A. Submit the following:
 - 1. Test Reports:
 - a. Submit certificate of completion, inspection and test by authority having jurisdiction on required piping systems.
 - b. Submit certificate of test approval by Owner's representative on all systems.
 - c. Test report shall contain description of the testing procedure and results, including recommendation for any remedial actions needed.
 - d. The Engineer's representative will record witnessed tests.

PART 2 PRODUCTS – NOT APPLICABLE

PART 3 EXECUTION

3.1 GENERAL

- A. Piping:
 - 1. Test prior to concealment, insulation being applied, and connection to equipment, fixtures, or specialties.
 - 2. Conduct tests with all valves but those used to isolate the test section 10 percent closed.
- B. Leaks: Repair all leaks and retest until stipulated results are achieved.
- C. Notification:
 - 1. Advise the Engineer 72 hours in advance of each test.
 - 2. Failure to so notify will require test to be rescheduled.
- D. Testing Equipment: Provide all necessary pumps, gauges, connections, and similar items required to perform the tests.

3.2 TESTING REQUIREMENTS

- A. Piping - General: Test all piping as noted below, with no leaks or loss in pressure for time indicated. Repair or replace defective piping until tests are completed successfully:

HVAC Systems	Test Pressure	Test Medium	Test Duration
Chilled Water	150 psig	Water	4 hours

END OF SECTION

SECTION 23 05 93

TESTING, ADJUSTING, AND BALANCING OF HVAC SYSTEMS

PART 1 GENERAL

1.01 SUMMARY

- A. Section describes testing, adjusting, and balancing of air and water systems specified in Division 23. Work shall generally consist of volume adjustments, speed adjustments, performing tests, recording equipment data and measurements, and preparing reports.
- B. Work Provided Under Separate Contract: Owner's Commissioning Administrator will provide testing, adjusting and balancing services. Work will be performed by a NEBB certified TAB Contractor. All work will be performed under the direct supervision of a NEBB certified Project Supervisor.
- C. Contractor shall provide the following related services:
 - 1. Incorporate balancing activities in Contractor's construction schedule.
 - 2. Attend pre-balancing coordination meeting.
 - 3. Provide access to the Work.
 - 4. Incidental labor, facilities, and equipment to assist TAB Contractor in conducting work.

1.02 RELATED SECTIONS

- A. 01 91 03 - GENERAL COMMISSIONING REQUIREMENTS
- B. 23 08 00 - COMMISSIONING OF HVAC

1.03 DEFINITIONS

- A. TAB: Testing, adjusting, and balancing
- B. BAS: Building Automation System. Automatic control system consisting of stand-alone or integrated digital controllers used to control HVAC equipment.
- C. NEBB: National Environmental Balancing Bureau
- D. Project Supervisor: Individual employed by TAB Contractor having administrative and technical responsibility for work performed under this Section

1.04 QUALITY ASSURANCE

- A. Contractor shall attend a pre-balancing coordination meeting with the Owner, Engineer, and Commissioning Administrator. Meeting agenda shall include: coordination of work between TAB Contractor and Control Contractor, balancing procedures, and sequencing and scheduling work.

1.05 SEQUENCING

- A. Pre-balancing meeting shall be conducted 30 days prior to start of balancing.
- B. Provide notification in the form of a Pre-TAB Checklist to Commissioning Administrator four weeks prior to each major mechanical system ready for balancing. Refer to SUBMITTALS below. Notification of changes in scheduled start date shall be made a minimum of 24 hours in advance. If required notification is not provided, Contractor shall compensate Owner for additional costs by Contract modification.
- C. Schedule adequate time in the construction schedule as determined by Commissioning Administrator for execution of TAB work. TAB work will be performed during normal business hours, and be completed prior to occupancy. The Owner will be compensated for additional TAB costs caused by the Contractor's failure to provide adequate time for TAB work by Contract modification.

1.06 SUBMITTALS

- A. Pre-TAB Checklist: A Pre-TAB Checklist is included in the Construction Checklists for the project. Contractor shall execute checklist and return to Owner's Authorized Representative once systems

are ready for testing adjusting and balancing. TAB Contractor will not begin balancing until a fully executed checklist is received.

PART 2 PRODUCTS

2.01 MATERIALS

- A. Provide all belts and sheaves for fans as required to meet scheduled fan RPM. Furnish additional belts and sheaves to balancer as required for balancer to obtain specified performance requirements.

PART 3 EXECUTION

3.01 BAS CALIBRATION AND TESTING

- A. TAB Contractor will perform tests as described below to determine the following BAS control setpoints and control parameters. BAS contractor shall provide all instruction, hardware and software necessary for the TAB contractor to perform work including but not limited to laptop computer, interconnecting cables, BAS application software, passwords, and on-site assistance of a qualified BAS technician.
 - 1. Outside air damper settings to achieve minimum ventilation rates under normal operating conditions
 - 2. Terminal unit cooling and heating, minimum and maximum airflow calibration values
 - 3. Pressure setpoints and/or reset schedules required for variable volume air system speed control to meet design load conditions
 - 4. Minimum pressure setpoints and/or reset schedules required for variable volume water system speed control to meet design load conditions

3.02 ACCESS TO WORK

- A. Contractor shall provide facilities and access for TAB Contractor to perform work including but not limited to:
 - 1. Keys, security passes, etc.
 - 2. Lifts where work is more than 12 feet above floor level
 - 3. Removal of ceiling tiles, partitions, panels, or other fixed construction necessary for completion of TAB work

END OF SECTION

SECTION 23 07 00
INSULATION FOR HVAC

PART 1 GENERAL

1.1 SUMMARY

- A. This Section includes:
 - 1. Pipe Insulation
 - 2. Ductwork Blanket Insulation
 - 3. Ductwork Board Insulation
 - 4. Accessories Piping
 - 5. Accessories Ductwork

1.2 RELATED SECTIONS

- A. Division 01, General Requirements
- B. Division 23, Heating, Ventilating, and Air Conditioning (HVAC)
- C. Section 23 05 29, Hangers, Supports and Anchors for HVAC
- D. Section 23 31 01, HVAC Ducts and Casing – Low Pressure

1.3 QUALITY ASSURANCE

- A. Regulatory Requirements:
 - 1. Prohibit insulating products from containing pentabrominated, octabrominated, and decabrominated diphenyl ethers. Where products within this specification contain these banned substances, provide complying products from approved manufacturers with equal performance characteristics.
 - 2. Flame and Smoke Ratings: Installed composite flame spread not to exceed 25 and smoke developed not to exceed 50 as tested by UL 723 or ASTM E84.
 - 3. Energy Codes: Local Building and Energy Codes govern where insulation performance requirements for thickness exceeds thickness specified.
- B. Protection:
 - 1. Protect against dirt, water, chemical, or mechanical damage before, during, and after installation.
 - 2. Repair or replace damaged insulation at no additional cost.
- C. Source Quality Control:
 - 1. Service: Use insulation specifically manufactured for service specified.
 - 2. Labeling: Insulation labeled or stamped with brand name and number.
 - 3. Insulation and accessories not to provide nutritional or bodily use to fungi, bacteria, insects, rats, mice, or other vermin, not to react corrosively with equipment, piping, or ductwork, and asbestos free.

1.4 SUBMITTALS

- A. Submit the following.
 - 1. Product Data: For each type including density, conductivity, thickness, jacket, vapor barrier, and flame spread and smoke developed indices.

PART 2 PRODUCTS

2.1 MANUFACTURERS

- A. Pipe Insulation:
 - 1. Fiberglass:
 - a. Johns Manville Microlok HP
 - 2. Elastomeric:
 - a. ArmacellAP Armaflex
 - b. Rubatex
 - c. K-Flex
- B. Ductwork Blanket Insulation:
 - 1. Fiberglass:
 - a. Johns Manville Microlite Type 100
 - 2. Semi-Rigid Fiberglass:
 - a. Johns Manville Micro-Flex
- C. Ductwork Board Insulation:
 - 1. Semi-Rigid Fiberglass:
 - a. Micro-Aire Duct Board Type LP
 - 2. Rigid Fiberglass:
 - a. Johns Manville Diffuser Board

2.2 PIPE INSULATION

- A. Fiberglass: Split sectional or Snap-On type with 0.23 per-inch maximum thermal conductivity (K-factor) at 75 degrees F mean temperature, 850 degrees F maximum service rating and white, vapor barrier jacket with pressure sensitive closure system.
- B. Elastomeric:
 - 1. Expanded closed cell, 0.27 per-inch maximum K-factor at 75 degrees F mean temperature, 220 degrees F maximum service rating with fitting covers and paintable surface.

2.3 DUCTWORK BLANKET INSULATION

- A. Fiberglass: 1.0 pcf nominal density, 0.25 per-inch maximum K-factor at 75 degrees F mean temperature, 250 degrees F minimum operating temperature limit.
 - 1. Exposed: FSK facing (foil scrim Kraft) or vinyl - white appearance.
 - 2. Concealed with Vapor Barrier: FSK reinforced foil and paper.
 - 3. Concealed without Vapor Barrier: Facing not required.
- B. Semi-Rigid Fiberglass: 2.5 pcf nominal density, 0.24 per-inch maximum K-factor, at 75 degrees F mean temperature, 250 degrees F minimum operating temperature limit.
 - 1. Exposed: FSK facing (foil scrim Kraft) or vinyl-white appearance.
 - 2. Concealed with Vapor Barrier: FSK reinforced foil and paper.
 - 3. Concealed without Vapor Barrier: Facing not required.
- C. Elastomeric: Expanded closed cell sheets, 0.27 per-inch maximum K-factor at 75 degrees F mean temperature and 220 degrees F minimum operating temperature limit.

2.4 DUCTWORK BOARD INSULATION

- A. Semi-Rigid Fiberglass: 0.23 per-inch maximum K-factor at 75 degrees F mean temperature, 250 degrees F minimum operating temperature limit and all-purpose vapor barrier facing with white Kraft paper finish.

- B. Rigid Fiberglass: Same as semi-rigid except with 4.0 pcf density and 0.23 per-inch maximum K-factor.

2.5 ACCESSORIES PIPING

- A. Adhesives:
 - 1. General: Maximum Flame Spread/Smoke Developed Rating of 25/50, SCAQMD Rule 1168 compliant.
 - 2. Fiberglass: Integral closure system.
 - 3. Calcium Silicate: Benjamin Foster 30-36.
- B. Cements:
 - 1. Insulating: Ryder.
 - 2. Heat Transfer: Chemax Tracit-300.
- C. Wire Mesh: 1-inch mesh with 20 gauge annealed steel wire.
- D. Pipe Fitting Covers: One piece PVC insulated pipe fitting covers. Zeston, Ceel-Co.
- E. Grooved Coupling Insulation: One piece PVC insulated fitting cover. Zeston, Ceel-Co.
- F. Metal Pipe Jacket: 0.016-inch thick aluminum jacket with formed fitting covers, aluminum snap straps and sealant.
- G. Cloth Facing: Presized fiberglass cloth.
- H. Tapes: Pressure sensitive, weather resistant, and for temperatures up to 150 degrees F. Zeston Z-tape.
- I. Paint: Ultraviolet resistant latex paint with special adherence capabilities to the PVC fitting covers, elastomeric, aluminum facing, Kraft paper, tapes, and adhesives.

2.6 ACCESSORIES DUCTWORK

- A. Adhesives:
 - 1. General: Maximum Flame Spread/Smoke Developed Rating of 25/50, SCAQMD Rule 1168 compliant.
 - 2. Fiberglass: Benjamin Foster 85-62, Design Polymerics 2501/2502
 - 3. Duct Insulation, Internal: Foster 85-62, Design Polymerics 2501/2502
- B. Weld Pins: Duro-Dyne with NC-1 nylon stop clips
- C. Cements:
 - 1. Insulating: Ryder.
 - 2. Heat Transfer: Chemax Tracit-300
- D. Wire Mesh: 1-inch mesh with 20 gauge annealed steel wire.
- E. Mastic: Chicago Mastic:
 - 1. Vapor Barrier: 17-475
 - 2. Outdoor Mastic: 16-110 white
- F. Cloth Facing: Presized fiberglass cloth
- G. Tapes: Pressure sensitive, weather resistant, and for temperatures up to 150 degrees F. Zeston Z-tape.
- H. Paint: Ultraviolet resistant latex paint with special adherence capabilities to the PVC fitting covers, elastomeric, aluminum facing, Kraft paper, tapes, and adhesives.

PART 3 EXECUTION

3.1 GENERAL

- A. Workmanship:
 - 1. Installation: Insulation installed in first class, neat professional manner.

2. Applicators: Employ by firm that specializes in insulation work.
- B. Preparation: Surfaces of piping, ductwork, and equipment clean, free of oil or dirt, and dry before insulation is applied.
- C. Stamps: ASME stamps, UL labels, and similar stamps and labels not covered.

3.2 HVAC PIPE AND EQUIPMENT INSULATION APPLIED LOCATIONS

A. Insulation Applied Locations – HVAC Piping:

System	Pipe Size	Insulation Type	Insulation Thickness	Notes
Chilled Water	1-1/4-inch and smaller	Fiberglass	1-inch	Note 1
Chilled Water	1-1/2-inch and above	Fiberglass	1-1/2-inch	Note 1
Condensate or other cold water drains	All	Elastomeric	1/2-inch	
Air Separators and Storage Tanks	All	Fiberglass	3-1/2-inch	
Note 1: Cover with metal pipe jacket where exposed to weather and over heat trace cable. Note 2: Refer to specification 23 20 14 for additional pre-insulated piping systems requirements. Note 3: Elastomeric insulation not allowed over heat trace cable. Note 4: Or per VRF manufacturer installation recommendations.				

- B. Include fittings, unions, flanges, mechanical couplings, valve bodies, valve bonnets, piping through sleeves, except valve bonnets, unions and flanges need not be insulated on the following systems:
 1. Condensate, pumped condensate, feed water, inside building.
- C. Piping insulation is not required between the control valve and coil on run-outs when the control valve is located within 4-feet of the coils and the pipe size is 1-inch or less.
- D. Valves, humidifier bodies, and irregular fittings insulated with section of pipe insulation and insulating cement, securely fastened, and finished with 6 ounces canvas and Foster 30-36 lagging adhesive.
- E. Option on flanges, valves, strainers, not requiring a vapor barrier to insulate with removable replaceable pads fabricated of 1-inch layer of Pittsburgh Corning Temp Mat sandwiched between inner and outer layer of 8 ounces glass cloth held together with stainless staples with sufficient stainless lacing hooks to hold pad firmly to flange or valve with minimum 3-inch overlap onto adjacent pipe insulation using 18 gauge SS lacing wire.
- F. Expansion Joints and Flexible Connectors: Pipe insulation or block of same material and thickness as adjacent piping.
- G. Chilled Water Pump Casings: 1-1/2-inch elastomeric.

3.3 PIPING INSTALLATION

A. General:

1. Joints: Coat both sides of complete joining area with applicable adhesive.
 - a. Longitudinal Joints: Make joints on top or back of pipe to minimize visibility. Except foam plastic, seal with closure system or 3-inch wide tape.
 - b. Butt Joints: Butt lightly together and, except for foam plastic, seal with 3-inch wide tape or butt straps.
 - c. Multiple Layered Insulation: Joints staggered.
2. Access: Strainer and other items requiring service or maintenance with easily removable and replaceable section of insulation to provide access.

3. Voids:
 - a. Fill voids, chipped corners and other openings with insulating cement or material compatible with insulating material.
 - b. In insulation with Heat Tracing: Where piping is shown or specified to be heat traced, bed heat tape into heat transfer cement with insulation over heat tape and cement.
4. Seal joints, seams, and fittings of metal watertight jackets at exterior locations.
- B. Fiberglass Insulation: Exterior insulation encased in metal jacket.
- C. Elastomeric Insulation:
 1. Slit full length and snap around pipe.
 2. Make cuts perpendicular to insulating surface leaving no cut section exposed.
 3. Do not stretch insulation to cover joints or fittings.
 4. Seal joints in elastomeric insulation with adhesive.
 5. Exterior insulation painted with two coats of specified paint in accordance with the manufacturer's instructions and encase in metal jacket.
 6. Sealing joints with tape will not be allowed.
- D. Fittings: Insulation specified with continuous vapor barrier, the vapor barrier must not be violated.
 1. On Elastomeric Insulation: Fittings covered with covers made up of mitered sections of insulation or with formed pipe fitting covers.
 2. In Other Insulation: Fittings covered with insulation to the same level of the adjoining insulation or fill with insulating cement. Finish with pipe fitting covers or cloth facing and tape.
- E. Unions, Mechanical Joints, Valves, etc.:
 1. General:
 - a. As specified for fittings.
 - b. Minimum thickness same as specified for piping.
 2. Unions: Build up insulation at least 1/2-inch beyond adjoining insulation.
 3. Flanges: With square corners. Where flanges are not insulated, terminate adjacent insulation so flange bolts can be removed.
 4. Flanged Valves: Insulation with square corners.
- F. Vapor Barrier Insulation:
 1. Refer to Section 23 05 29 Hangers, Supports, and Anchors for HVAC, for support requirements.
 2. Piping which requires vapor barrier protection has a continuous vapor barrier, which may not be pierced or broken. The following piping systems require vapor barrier protection:
 - a. Chilled water including radiant cooling water.
 - b. Brine water.
 - c. Refrigerant suction.
 - d. Other piping systems with a nominal operating temperature below 65 degrees F.
 3. Vapor Barrier Insulation.
 - a. Insulation for pipe requiring vapor barrier protection 1-1/4-inch or smaller, insulation continuous through pipe hangers and rollers.

- b. For pipe 1-1/2-inch and larger, 18-inch section of calcium silicate, same thickness as pipe insulation with continuous vapor barrier jacket at each hanger or roller. Provide pipe shield specified in Section 23 05 29, Hangers, Supports, and Anchors for HVAC.
- G. Non-Vapor Barrier Insulation:
- 1. Refer to Section 23 05 29, Hangers, Supports, and Anchors for HVAC for support requirements.
 - 2. Pipe 1-1/4-inch or Smaller: Isulation continuous through pipe hangers and rollers.
 - 3. Pipe 1-1/2-inch and Larger:
 - a. 18-inch section of calcium silicate, same thickness as pipe insulation.
 - b. Provide pipe shield specified in Section 23 05 29, Hangers, Supports, and Anchors for HVAC.

3.4 EQUIPMENT INSTALLATION

- A. General: Install true and smooth. Insulation over curved surfaces conform to curves of surface.
- 1. Access:
 - a. Insulated removable heads, water boxes, pump casings, access, etc., that require service, inspection or maintenance provided with covers or section that are easily removable and replaceable.
 - b. Reinforce openings in adjacent insulation with metal beading.
 - c. In vapor barriered insulation, coat joints with vapor barrier mastic.
 - 2. Voids, Depressions and Cavities: Voids, chipped corners and other openings filled with insulating cement or material compatible with insulating material.
 - 3. Vapor Barriered Insulation:
 - a. Where insulation is specified to have a vapor barrier.
 - b. No broken or pierced barrier.
 - 1) Coated with vapor barrier mastic and patched with insulation facing or tape.
 - 2) Staples brush coated with vapor barrier coating.
 - 3) Raw edges coated with vapor barrier mastic covered and cover sealed to equipment surface.
 - 4. Non-Vapor Barriered Insulation:
 - a. Patch with insulation facing or tape.
 - b. Cover raw edges and neatly bevel to the equipment surface.
 - 5. Multilayered Insulation: With staggered joints.
- B. Expansion Joints:
- 1. Covered with larger size pipe insulation to allow full movement and be removable, ends turned back to pipe, coat with vapor barrier mastic on joints in vapor barriered system, and finished with cloth facing cemented to insulation with adhesive.

3.5 DUCT INSULATION APPLIED LOCATIONS

- A. General:
- 1. Provide external insulation with continuous vapor barriers unless specifically noted otherwise.

B. Insulation Applied Location – HVAC Ductwork:

System	Location	Duct Type	Insulation Type	Thickness	Notes
Medium Pressure Supply*	Exposed or Visible (Including above a cloud ceiling)	Rectangular	Internally Lined	1-1/2-inch	
		Round/Oval	Internally Lined	1-1/2-inch	
	Concealed or in mechanical rooms	All	Fiberglass Blanket	1-1/2-inch	
Low Pressure Supply*	Exposed or Visible (Including above a cloud ceiling)	Rectangular	Internally Lined	1-1/2-inch	
		Round	Internally Lined	1-1/2-inch	Note 1
	Concealed or in mechanical rooms	All	Fiberglass Blanket	1-1/2-inch	
<p>* In addition to applied locations listed in this table, provide internally lined ductwork where indicated on drawings. Note 1: Where round or oval ductwork is indicated, provide double walled round/oval ductwork as specified in Section 23 31 02, HVAC Ducts and Casing-Medium Pressure, or provide internally lined rectangular ductwork with equivalent free area may be substituted.</p>					

3.6 DUCTWORK INSTALLATION

A. General:

1. Install in accordance with manufacturer's instruction.
2. Continuous vapor barrier. Coat with vapor barrier mastic and patch with facing or tape. Joints between insulation and access with vapor barrier mastic.
3. Insulation at access panels to be removable or attached to panel with edges of panel and opening reinforced with metal beading.

B. External Blanket Insulation:

1. Insulation secured to ductwork with 20-gauge snap wires 24-inches on center and at all joints.
2. Joints and seams lapped a minimum of 3-inches and sealed with jacket tape.

C. Board Insulation:

1. Rectangular ducts with weld pins spaced a maximum of 18-inches on center in both directions.
2. Corners made with joints, bending insulation around corners not allowed.
3. Joints and seams butted tight together.
4. Butt joints with 3-inch wide tape.
5. Corners finished with 3-inch wide tape.

D. Volume Dampers: Where volume dampers do not allow for continuous insulation, terminate insulation clear of handle sweep, and finish edges to maintain vapor barrier and to prevent damage to the insulation.

3.7 FIELD QUALITY CONTROL

A. Field Test: Test and approve systems prior to installation of insulation.

B. Existing Insulation:

1. Repair existing insulation damaged during construction.
2. Make neat connections where new and existing insulation meet.

3. Where existing piping, ductwork or equipment is removed, cover existing surfaces neatly to match existing.
4. Where existing insulation is damaged or missing, notify the architect prior to performing to work.

END OF SECTION

SECTION 23 08 00
COMMISSIONING OF HVAC

PART 1 GENERAL

1.01 SUMMARY

- A. Section includes Commissioning activities required for work of Division 23 Sections including but not limited to construction checks, equipment start-up, functional testing, and operator training.
 - 1. Comply with Section 01 91 13 – General Commissioning Requirements for Commissioning activities for Division 23 work.

1.02 SEQUENCING

- A. Provide written notification to Commissioning Administrator (CA) in advance of significant project dates as directed and as listed below.
 - 1. Two weeks prior to start-up of air handling units, air-conditioning units, exhaust fans, boilers and pumps
 - 2. Four weeks prior to installation of lay-in ceiling tiles or other partial concealment of equipment to be commissioned
 - 3. Four weeks prior to any system ready for balancing

1.03 SUBMITTALS

- A. Provide control system custom software, hardware, and technical manuals as necessary for development of Commissioning activities. Control system submittals include but are not limited to operating sequences, point database, workstation remote access, on-site custom programming/editing software, and programming and operations manual as necessary for development of Commissioning activities. Submit a minimum of 12 weeks prior to equipment start-up.
- B. Provide sample control verification report to Commissioning Administrator 12 weeks prior to substantial completion. Submittal shall show format and content of Final Verification Report.
- C. Provide submittals of systems being commissioned to Owner's Authorized Representative as required by Section 01 91 13.
- D. Provide electronic copies (or hard copies where appropriate) of control system final configuration parameters, programs, databases, files, and electrical data as necessary to reconfigure and/or replace control components upon device failure.

PART 2 PRODUCTS

2.01 MATERIALS

- A. Provide all necessary control hardware, software, and temporary licenses to enable Commissioning Administrator to conduct activities and to fully access any electronic control systems furnished for this project. Commissioning Authorities' laptop computer may be used for access if software and hardware systems provided are compatible with existing computer configuration, otherwise furnish laptop computer where required for duration of project.
- B. Provide minimum of two HVAC control operator interface sites for both on-site and remote access as described below:
 - 1. Commissioning Administrator Access Functions: Review and modification of control programming, monitoring of control system operations, review and modification of software database, setup and monitoring trend data in tabular and graphical formats.
 - 2. Remote Access: Remote access using Internet and shall include all functions described above.
 - 3. Provide credentials for Commissioning Administrator. Security access level shall be suitable to perform necessary commissioning functions.

4. Provide labor required to install hardware and software on personal computers at Commissioning Administrator's office. Software will be manufacturer's most recent version and will be compatible with the CA's personal computers. Provide Commissioning Administrator with two hours training after fully functional remote access is established.

PART 3 EXECUTION

3.01 FIELD QUALITY CONTROL

- A. Manufacturer's Field Services: Manufacturer's Representative to execute Construction Checklists and perform operational training as specified in Division 23 including the following systems:
 1. Chiller
 2. Variable frequency drives
 3. Building Automation System

3.02 CONSTRUCTION CHECKLISTS

- A. Contractor shall execute as required by Section 01 91 13 Construction Checklists for each system commissioned will be prepared by Commissioning Administrator during construction.

3.03 CONTROL VERIFICATION REPORTS

- A. Building Automation System: BAS control contractor shall perform verification of the function and performance of control hardware and software. Provide verification report demonstrating proper system installation and operation. Verification report shall include the following:
 1. Network Communication: Verify that all network devices properly communicate on network. Verify communication speed and reliability is acceptable.
 2. Input and Output Verification:
 - a. Verify that all input and output points are indicating properly. Verification tests shall be "end-to-end" meaning field measurement to workstation graphic display value.
 - b. Calibrate all analog inputs. Acceptance accuracy shall be as specified for product accuracy. Repair or replace all devices that do not conform to specified accuracy.
 - c. Operate all analog outputs from 0% to 100% of operating range. Verify that controlled device operates over the entire output range and that maximum and minimum operating conditions are achieved.
 - d. Valves and dampers shall close fully and provide tight shutoff. Leakage rates shall not exceed specified values.
 - e. Verify that all digital outputs operate controlled devices.
 3. Sequence of Operation Verification: Systematically verify automatic control sequence of operation functions in field after installation is complete. Verification shall include:
 - a. Time scheduling
 - b. Operating modes
 - c. Tune and adjust control loops and control sequences to optimize efficiency and performance. Control loops shall be stable and maintain desired setpoints.
 4. Trending: Confirm trending utilities storage of operating data as required to verify operation and performance of control modes, sequence, and loops. Meet with Owner and CA to review configuration, parameter interval, and duration prior to trend setup.
 5. Operator Interface: Review function of operator interface. Confirm that graphic operator interface accurately depicts as-constructed system configuration and that all required content is displayed and functions as intended.
 6. Alarms: Confirm alarm utilities are configured as required, alarm conditions are displaying in alarm logs, on graphic displays, and provide annunciation and reporting as required. Meet with Owner and CA to review configuration parameters prior to alarm utility setup.
 7. Coordination: Assist balancing contractor with development of control setpoints and parameters as specifically indicated or otherwise required to provide Sequence of Operation. Setpoints would include but would not be limited to actuator positions required to provide minimum ventilation rates, supply air pressure setpoints for variable air volume air distribution systems, and terminal unit calibration parameters.

8. Controls Verification Report: After system operation is completely verified, provide written certification to Owner that systems have been fully tested, are operating according to specifications and ready for functional testing. Include documentation to the Commissioning Administrator detailing verification results. Report shall include:
 - a. Updated control construction drawings and equipment data that incorporates all changes made during construction
 - b. Printed as-built control code
 - c. Printed point data base
 - d. Input/Output Verification Log: Submit point verification log including point identification, control system readout value, verification measurement, and required calibration offset where applied.
 - e. Sequence of Operation Verification: Submit verification test report listing complete text of control sequence and test results. Verify all specified control sequences.
 - f. Trend Logs: Submit printed trend reports for the following:
 - 1) Time schedules. Seven-day log demonstrating that equipment operates according to programmed time schedules.
 - 2) Automatic control sequences. Trends shall be set-up as follows:
 - a) Analog Control: Points that modulate over time shall be sampled at appropriate intervals and durations to demonstrate proper operating sequences. For example, a discharge temperature control loop would require trending during the morning warm-up mode and normal daytime operation mode. Each trend shall include all measured variables, control output signal, actual output signal, and controlled variable.
 - b) Digital Control: Dual-state control or monitoring points shall be recorded as COV (+) or change of value meaning that the changed parameter only needs to be recorded after the value changes from its previous state. A minimum of one week of samples shall be provided to properly demonstrate equipment cycles, modes, and schedules.
 - g. Include trend graphs as described below:
 - 1) Lines shall be labeled and shall be distinguishable from each other by using either different line types, or different line colors.
 - 2) Indicate engineering units of the y-axis values; e.g., degrees F., inches w.g., Btu/lb, percent wide open, etc.
 - 3) The y-axis scale shall be chosen so that all trended values are in a readable range. Do not mix trended values on one graph if their unit ranges are incompatible.
 - 4) All points trended for one HVAC subsystem; e.g., air handling unit, chilled water system, etc. shall be trended during the same trend period.
 - 5) Each graph shall be clearly labeled with HVAC subsystem title, date, and times.
 - h. List of incomplete work.
9. Demonstration: Demonstrate operation of control system to Engineer, Commissioning Administrator, and Owner including:
 - a. Menu functions
 - b. Point overrides
 - c. Control loop response after point modification
 - d. Alarm response time

3.04 FUNCTIONAL TESTING

- A. Contractor shall assist Commissioning Administrator with functional testing as required by Section 01 91 13. Functional Test Plans for each system being commissioned will be prepared by Commissioning Administrator during construction, and will generally include a rigorous verification of instrument calibration, equipment performance, packaged equipment control system operations, automatic control sequence of operations, fire and life safety sequences, and operator

interface functions. Commissioning Administrator will supervise and document functional testing. Contractor shall provide qualified technicians to assist Commissioning Administrator during on-site testing and perform the following functions.

1. Operate equipment and systems as necessary to conduct testing.
 2. Manipulate control parameters to simulate test conditions as detailed in Functional Test Plans.
 3. Access control programming and database as required to verify control configuration or to correct observed deficiencies.
 4. Create graphic displays and/or trend report as required to document test results.
 5. Provide proprietary hardware and software as needed to interface with manufacturer's packaged control systems.
- B. Labor required for retesting due to failure of equipment, or systems not performing in accordance with Contract Documents shall be provided at no additional cost to Owner.

3.05 OPERATIONS AND MAINTENANCE TRAINING

- A. Provide operation and maintenance instruction to Owner's personnel as required by Division 01 and 23.

3.06 SCHEDULE OF SYSTEMS BEING COMMISSIONED

- A. Commission systems and equipment listed below including associated equipment, piping, ductwork, and control systems.
- B. HVAC Systems: Chiller, associated chilled water piping, accessories and pumps, new terminal units, fan coil unit, FU-2.

END OF SECTION

SECTION 23 09 00
INSTRUMENTATION AND CONTROLS FOR HVAC

PART 1 GENERAL

1.1 SUMMARY

- A. This Section includes:
 - 1. Materials and Equipment
 - 2. Control Devices
 - 3. DDC Field Panels
 - 4. Connection to Existing Network
 - 5. BACnet Compatibility
 - 6. Operator Interface System
 - 7. Application Programs
 - 8. Input/Output Functions
 - 9. Uninterruptable Power Supply
 - 10. Energy Management System

1.2 RELATED SECTIONS

- A. Division 01, General Requirements
- B. Division 23, Heating, Ventilating, and Air Conditioning (HVAC)
- C. Section 23 05 93, Testing, Adjusting and Balancing
- D. Section 23 08 00, Commissioning for HVAC
- E. Section 23 21 13, Pipe and Pipe Fittings HVAC

1.3 QUALITY ASSURANCE

- A. Provide control work by single company with specialists in the type of work required, so that only one control manufacturer is responsible for control and automation work for project.
- B. Provide coordination with other contractors or subcontractors for work required by other trades for accomplishment of control work.
- C. Prior to substantial completion, controls contractor must demonstrate to Owner that system is operating per the Specifications and final adjustments have been made as approved.
- D. System, including components and appurtenances, configured and installed to yield a Mean Time Between Failure (MTBF) of at least 1,000 hours.

1.4 SUBMITTALS

- A. System Drawings: Prepare on AutoCAD format and include the following:
 - 1. Equipment installation, block diagrams, and wiring diagrams.
 - 2. DDC panel physical layout and schematics.
 - 3. Sensor and control wiring and installation drawings which identify each component and show interconnected or interlocked components.
 - 4. Material and equipment descriptive material such as catalog cuts, diagrams, performance curves, and other data to demonstrate conformance with specifications.
 - 5. Details of connections to power sources, including grounding.
 - 6. Details of surge protection device installations.
 - 7. Instrumentation and control diagrams.
 - 8. Complete a written description of control sequences.

9. List of connected data points, including DDC panels to which they are connected, and input device (sensor, etc.).
10. Valve and damper schedules indicating flows, pressure drops, CVs, and actuator type.
11. Graphics: System graphics for review prior to implementation of programming.
- B. Equipment Data: Submittals include complete data for materials, including field and system equipment.
- C. Software Data:
 1. Submittals consist of complete descriptions of system, command, and applications software as specified.
 2. Include description of control sequences which are software based using detailed logic flow diagrams.
 3. Diagrams indicate logic used to achieve control sequence of calculation specified, and show relationship between control sequence and application software packages specified.
- D. Testing Submittals:
 1. Provide test plan and test procedures for approval.
 2. Explain in detail, step-by-step actions and expected results to demonstrate compliance with the requirements of this specification and methods for simulating necessary conditions of operation to demonstrate performance of the system.
 3. Test plan and test procedures demonstrate capability of system to monitor and control equipment and to accomplish control and monitoring specified.
- E. Operation and Maintenance Manuals:
 1. Provide three complete sets of manuals bound in loose-leaf binders within 30 days after completing acceptance tests.
 2. Identify each manual's contents on cover.
 3. Manuals include names, addresses, and telephone numbers of each subcontractor installing equipment and systems and of nearest service representatives for each item of equipment and each system.
 4. Place tab sheets at beginning of each chapter or section and at beginning of each appendix.
 5. Final copies delivered after completion of the acceptance tests include modifications made during installation, checkout, and acceptance.
 6. Operation and Maintenance Manuals to include hardware manual, software manual, operations manual, and maintenance manual.
 7. Hardware Manual: Furnish a hardware manual describing equipment provided, including:
 - a. General description and specifications.
 - b. Installation and checkout procedures.
 - c. Equipment electrical schematics and layout drawings.
 - d. System schematics and I-O wiring lists.
 - e. Alignment and calibration procedures.
 8. Software Manual:
 - a. Describe furnished software.

- b. Oriented to programmers and describe calling requirements, data exchange requirements, data file requirements and other information necessary to enable proper integration, loading, testing, and program execution.
 - c. Provide one software manual per Operator's Terminal.
9. Operator's Manual: Provide procedures and instructions for operation of the system, including:
- a. DDC Panels and Peripherals
 - b. System start-up and shutdown procedures.
 - c. Use of system, command, and applications software.
 - d. Alarm Presentation
 - e. Recovery and Restart Procedures
 - f. Report Generation
 - g. System Schematic Graphics
 - h. Provide one Operator's Manual per Operator's Terminal
10. Maintenance Manual: Provide descriptions of maintenance for equipment including inspection, periodic preventive maintenance, fault diagnosis, and repair or replacement of defective components.
11. Acceptance Test Forms: Maintenance manual includes copies of signed-off acceptance test forms.

1.5 ACCEPTANCE TESTING AND TRAINING

- A. Site Testing:
- 1. General: Provide personnel, equipment, instrumentation, and supplies necessary to perform testing. Owner or Owner's representative will witness and sign off on acceptance testing.
 - 2. Acceptance Test: Demonstrate compliance of completed control system with contract documents. Using approved test plan, physical and functional requirements of project demonstrated.
- B. Training:
- 1. General:
 - a. Conduct training courses for designated personnel in operation and maintenance of system.
 - b. Oriented to specific system being installed under this contract.
 - c. Provide trainee with two additional copies provided for archival at project site.
 - d. Manuals include detailed description of the subject matter for each lesson.
 - e. Provide copies of audiovisuals to Owner.
 - f. Training day is defined as 8 hours of classroom instruction, including two, 15-minute breaks and excluding lunch time, Monday through Friday, during normal first shift in effect at training facility.
 - g. Notification of any planned training given to the Owner's representative at least 15 days prior to the training.
 - 2. Operator's Training:
 - a. Teach course at project site for a period of one training day after completion of Contractor's field testing.
 - b. Include instruction on specific hardware configuration of installed system and specific instructions for operating the installed system.

- c. Upon completion, each student able to start system, operate the system, recover the system after failure, and describe the specific hardware architecture and operation of system.

PART 2 PRODUCTS

2.1 MANUFACTURERS

- A. Johnson Controls by JCI
- B. Unless otherwise noted, installed by manufacturer.

2.2 SYSTEM DESCRIPTION

- A. General:
 - 1. Provide a complete control system, consisting primarily of electronic direct digital control devices.
 - 2. System consists of modular and distributed microprocessor based control and monitoring units connected together by communications trunks. Capable of global data sharing and communication between controllers.
 - 3. System architecture distributed and not rely on central processing unit (CPU) for sharing point data between controllers, or for control functions requiring data from other controllers.
 - 4. Multipurpose controller(s) consisting of CPU, system program, memory, power supply, and input/output drivers which communicated with terminal equipment controllers through a communications network.
 - 5. Provide operator's interface.
 - 6. Provide equipment, installation, wiring, and accessories as required but not necessarily specified to accomplish operations as described.
- B. Environmental Conditions:
 - 1. Rate DDC panels and other field equipment for continuous operation under ambient environmental conditions of 35 degrees F to 120 degrees F dry bulb and 10 percent to 95 percent relative humidity, noncondensing.
 - 2. Instrumentation and control elements rated for continuous operation under the ambient environmental temperature, pressure, humidity, and vibration conditions specified or normally encountered for the installation.
 - 3. Install control devices in an enclosure suitable for the installed environment.
- C. System Accuracy and Display:
 - 1. DDC system to control space temperature with a range of 50 degrees F to 85 degrees F ± 1 degrees F for conditioned space (display to nearest 0.5 degrees F); 15 degrees F to 130 degrees F ± 1 degrees F for unconditioned space (display to nearest 0.5 degrees F). Return air humidity controlled to 20 percent RH to 35 percent RH ± 3 percent RH.
 - 2. DDC system to control duct temperature with a range of 40 degrees F to 140 degrees F ± 1 degrees F (display to nearest 0.5 degrees F).
 - 3. Water temperature with a range of 30 degrees F to 100 degrees F ± 1 degrees F (display to nearest 0.5 degrees F); the range of 100 degrees F to 300 degrees F ± 2 degrees F (display to nearest 0.5 degrees F); and water temperatures for the purpose of performing BTU calculations using differential temperatures to ± 0.5 degrees F using matched sensors (display to nearest 0.5 degrees F).
 - 4. Pressure with a range for the specific application ± 5 percent of range.

2.3 MATERIALS AND EQUIPMENT

A. Controls and Power Wiring:

1. General: Electric equipment and wiring in accordance with Division 26, Electrical. Manual or automatic control and protective or signal devices required for operation specified, and control wiring required for controls and devices.
2. Wiring:
 - a. Field and Subfield Panels:
 - a) Voltage in panels not to exceed 120V. Where devices are wired to higher voltages, mount in suitable individual enclosures or group in separate control panel.
 - b) Coordinate electrical power supply with Division 26.
 - b. Motor Control Centers: Responsibility for correct voltage of holding coils and starter wiring in pre-wired motor control centers interfacing with automatic controls is included hereunder.
 - c. Wiring for DDC systems communications buses two conductor minimum 18 gauge foil-shielded, stranded twisted pair cable rated at 300 VDC or more than 80 degrees C.
3. Communications Links Surge Protection: Protect communications equipment against surges induced on any communications link. Cables and conductors which serve as communications links have surge protection circuits installed that meet the requirements of REA PE-60d.
4. Communications Links Overvoltage Protection: Protect communications equipment against overvoltage on any communications link conductors. Cables and conductors which serve as communications links have overvoltage protection for voltages up to 480 VAC rms, 60 Hz installed. Instrument fuses or fusible resistors are acceptable for this application.
5. Power Line Surge Protection:
 - a. Protect equipment connected to AC circuits from power line surges.
 - b. Do not use fuses for surge protection.

B. Control Panels:

1. Provide wall-mounted control panels as required to contain relays, terminal strips, power supplies and other equipment in building control system.
2. UL listed, minimum NEMA 1, minimum 14 gauge steel with stiffeners, continuous hinge doors, locking handles, single point latch.

2.4 CONTROL DEVICES

A. Temperature Instruments:

1. Room Temperature Sensors: Platinum RTD type with accuracy of ± 0.4 degrees F at 70 degrees F; operating range 30 to 120 degrees F; linear to DDC system; single point sensing element in wall-mounted ventilated enclosure with insulating back plate if mounted on exterior wall.
 - a. Provide sensor with digital display.
2. Duct Temperature Sensors: Platinum RTD element with accuracy of ± 0.5 degrees F at 32 degrees F, averaging type consisting of array of single point sensing elements, securely mounted in duct or plenum; operating range 0 to 100 degrees F; linear signal; 20-foot element.
3. Low Temperature Limit Thermostat: Minimum 20-foot capillary sensing element, triggering on low temperature as sensed by any 6-inch segment; snap acting, normally open contacts, manual reset, line voltage.

4. Liquid Immersion Temperature Sensor: Platinum RTD element, with accuracy of ± 0.5 degrees F at 32 degrees F, stainless steel well and assembly, range 40 to 240 degrees F.
- B. Motorized Valves:
1. Equip with equal percentage with tight shutoff.
 2. Two position valves line size (two position ball valves full port), modulating water valves sized at 5 psi drop or as shown on the Drawing.
 3. Screwed ends except 2-1/2-inch and larger valves with flanged ends.
 4. Select valves to modulate smoothly at system pressures and flows.
 5. Select valves with close-off ratings and spring ranges designed to operate at the maximum flows and maximum available pump heads scheduled without leakage.
 6. Bubble tight butterfly valves acceptable on 2-1/2-inch lines and above for two-position action only.
 7. Air handling unit heating and cooling coil valves sized for 5 psi drop, unless otherwise noted on drawings.
- C. Valve and Damper Operators:
1. Electronic modulating actuators with low voltage DC or current positioning signal.
 2. Each actuator have current limiting circuitry incorporated in its design to prevent damage to the actuator.
 3. Modulating actuators be provided and accept 0-10 VDC or 2-10 VDC or 4-20 mA input signal.
 4. Actuators provide the minimum torque required for proper close-off against the system pressure for the required application.
 5. The spring return feature permits normally open or normally closed positions of the valve or damper.
 6. Direct shaft mount rotational actuators have external adjustable stops to limit the travel in either direction.
 7. Power actuators by 24 VAC.
 8. The actuator provides a clamp position feedback signal of 2-10 VDC. The feedback signal independent of the input signal, and may be used to parallel other actuators and provide true position indication.
- D. Flow Switches:
1. Provide McDonnell Miller or approved equal.
 2. Install in piping to eliminate nuisance fluttering.
 3. Provide time delay relays where required to eliminate false alarms when equipment is started.
 4. Differential pressure type.
 5. Current switches set for pump or fan normal current ranges are acceptable.
- E. Differential Pressure Switch:
1. Required for proof of flow on fans and pumps.
 2. Setpoint adjustable with operating range of 0.5 to 12-inches w.g. for fans, and 5-feet to 30-feet w.c. for pumps.
 3. Close when set pressure differential is met or exceeded.
- F. Differential Pressure Transducer:
1. Provides value of pressure drop across filter bank through DDC system.

2. Operating range 0 to 2 inches w.c., linear, accurate to ± 2.5 percent of span.
- G. Duct Static Pressure Transmitter:
1. Operating range 0 to 5-inches w.c. for duct mounted transmitter and 0 to 5-inches w.c. for fan high limit transmitters.
 2. Sensors either diaphragm or rigid element bellows, electronic type.
 3. Each transmitter be provided with stop cock and tubing for attacking portable pressure gauge.
 4. Sensing tube securely mounted in duct with appropriate fitting.
 5. Accuracy ± 1 percent of span, maximum response time 1 second.
- H. Current Transformer:
1. Current status switch, adjustable setpoint 1-135A, ± 1 percent of range, capable of monitoring motor's status and detection of belt breaking or slipping.
 2. Manufacturer:
 - a. Hawkeye 700
 - b. Or equal.
- I. Piping Pressure Transmitter:
1. Operating range 0 to 50 psig, linear to DDC.
 2. Provide threadolet for mounting to pipe installed by others.
 3. Accuracy ± 1 percent of range.
- J. End Switches:
1. Turret head type SPDT
 2. Manufacturer:
 - a. Square D Class 9007, Type C54B2
 - b. Or equal.
- K. VAV Actuators:
1. Proportional 24 VAC actuators using a 4 to 20 mA range of control signals
 2. Stop automatically at end of travel and include a permanently lubricated gear train.
 3. Furnished by the controls manufacturer and factory installed and tested by the terminal unit manufacturer.
- L. Water Flow Meters:
1. Provide Vortex flow meter that provides output signals, which are linear with the flow rate.
 2. Accuracy ± 1 percent of measurement for volumetric flow rates greater than 5 percent of specified maximum flow rate for each building.
 3. Flowmeters provide specified accuracy when installed and configured for upstream minimum straight runs of 24-inches.
 4. Vortex flow meters will be Intelligent microprocessor-based, with integral LCD digital Display/Configurator allowing complete commissioning and operation without external programming devices.
 5. Meter design permits maintenance and repair of flow sensor and electronics without removing the meter from line or shutting down steam flow.
 6. Flowmeter to have turn down ration of 50:1 or higher.
 7. ANSI 150 flanged end connections, wafer style is not acceptable.
 8. Flange size of the adjoining pipe of the same nominal size as the flow meter.

9. Mount flow meter in a straight, unobstructed pipe with a minimum of 10 pipe diameters upstream of the meter and 5 pipe diameters downstream, compensating for any induced flow effects according to manufacturer's recommendations.
 - a. Maximum Operating Pressure: 400 psi
 - b. Output Signal: Analog 4-20mA signal
 - c. Supply Voltage: 24VDC
 - d. Interrogation: FoxCom version
 - e. Based on: FoxBoro I/A Series Intelligent Vortex Flow Meter 83
- M. Water Flow Meter: Insertion style single turbine flow meters.
 1. Accuracy: ± 2 percent of reading from 0.4-20 feet/sec
 2. Liquid Temperature Range: 15-200 degrees F
 3. Maximum Operating Pressure: 400 psi
 4. Output Signal: 0-15 V peak Pulse
 5. Pipe Size Range: Minimum 1-1/4-inch
 6. Installation: 20 pipe diameters up and 5 pipe diameters down, or manufactures recommendations
 7. Display:
 - a. Provide BTU meter Onicon system 10
 8. Based On: Onicon F-1100
 - a. Accuracy: ± 2 percent of reading from 0.4-20 feet/sec
 - b. Liquid Temperature Range: 15-200 degrees F
 - c. Maximum Operating Pressure: 400 psi
 - d. Output Signal: 0-15 V peak Pulse
 - e. Pipe Size Range: Minimum 1-1/4-inch
 - f. Installation: 20 pipe diameters up and 5 pipe diameters down, or manufactures recommendations

2.5 DDC FIELD PANELS

- A. Multipurpose Controllers:
 1. Stand-alone microprocessor based panels, enclosed in sturdy metal enclosure with two standard RS232 interface ports, network communications module, power supply, and battery back-up.
 2. Panels will be used to connect field sensors and control devices. Fully supervise each panel to detect failures. Construct panel so functions are implemented on replaceable circuit boards to permit field maintenance. Completely field programmable through portable terminal. Minimum 8-hour battery backup system.
 3. Each DDC panel linked with data trunk cable to other controllers and Operator's Terminals to distribute information. Field panels continuously exchange data through trunk cable without requiring output to input wiring between panels. The system arranged so that operations are maintained without the central computer being connected to the system.
 4. Upon failure of the DDC field panel, including transmission failure, the panel automatically forces the controls to remain in the last command status.
 5. Provide a real time clock with calendar maintaining seconds, minutes, hours, and days of the week, accurate to ± 10 seconds per day.

6. Provide sufficient memory to perform specified and shown DDC field panel functions and operations, including spares. Each DDC panel to have 10 percent minimum spare memory board spacing.
7. Each DDC field panel contain hardware to support power fail automatic restart.
8. Provide locking type mounting cabinets with common keying.
9. DDC field panel have built-in diagnostics to display to operator interface terminal any sensor transmitting signal out of its design range.
10. Control logic done with software resident in each local DDC panel. Auxiliary relays may be used only when required for load contact rating.
11. Panels UL listed.

2.6 CONNECTION TO EXISTING NETWORK

- A. General: Communication between peer-to-peer DDC control panels via TCP/IP over the existing Ethernet system.
- B. Provide software and system integration to seamlessly integrate to the existing server for common system graphics, alarming, paging out of alarms via existing paging system.

2.7 BACNET COMPATIBILITY

- A. DDC System and components BACnet Data Communications Protocol compliant.
- B. System fully integrated and installed as a complete package of BACnet compliant controls and instrumentation.
- C. Capable of seamless BACnet integration with existing BACnet compliant devices as well as future BACnet compliant devices.
- D. No portals or third party devices required for integration with existing or future equipment.
- E. Devices utilized in the BACnet interface BACnet Testing Laboratories (BTL) listed and labeled.

2.8 OPERATOR INTERFACE SYSTEM

- A. Web-Based Access:
 1. Provide a web-based controls interface with at least three user login accounts and password each with the capability of different access privileges that performs data access, operator's commands, alarm notification, requests for reports, file generation, diagnostics, and modifications.
 2. Controls accessible in mechanical room by direct connection from a laptop to a data port.
 3. Provide a temporary computer located on-site in the mechanical room until the commissioning, testing, and balancing has been completed.
 4. Provide a temporary computer located on-site in the mechanical room, with software and capabilities necessary to support commissioning, testing, and balancing and other activities required for project completion.
- B. Graphics: Provide a complete graphics package with the following features:
 1. Provide separate schematic diagram depicting each system. Diagrams to show major components such as fans, dampers, heating and cooling coils, humidifiers, pumps, heat exchangers, chillers, boilers, towers, ductwork, piping, etc., arranged to convey to viewer system configuration and flow of each system.
 2. Provide plot plan, riser plan, and selected floor plans of buildings with the location of each mechanical room and major equipment location indicated.

3. Provide symbols superimposed on each schematic to indicate each control device including control valves, damper motors, temperature sensors, pressure sensors, etc. Provide real time dynamic displays of the temperature, humidity, pressure, flow rate, run status, alarm status, and etc., adjacent to each control symbol. Arrange CPU to update each displayed analog and digital value minimum of every 15 seconds.
 4. Provide indication of setpoints, with each setpoint value located adjacent to each sensed value.
 5. Provide means to allow the user to easily change or add graphics via computer assisted drawing function utilizing freehand mouse.
 6. Provide means to allow user to transfer repeated system schematics and symbols between graphics without redrawing them. Provide symbol library arranged to store commonly used symbols.
 7. Provide a "telescoping" or "zoom" program to allow use to move from plot plan to mechanical room plan to system graphic to control device display by simply clicking the mouse.
 8. Provide dual function windowing program to allow user to view a split screen and toggle between simultaneous operations.
- C. Trend Data Collection and Historical Data:
1. Provide trending capabilities that allow the user to easily monitor and preserve records of system activity over an extended period of time. Any system point may be trended automatically at time-intervals, time-synchronized intervals, change of value, or by event of which user-definable. Trend data collected and stored on hard disk for future diagnostics and reporting. Automatic trend collection may be scheduled of zones, events, and reports. Additionally, trend data may be archived to network drives or removable disk media for future retrieval.
 2. Provide trend data reports to allow the user to view trended point data. Display data in both tabular and graphical format. Reports may be customized to include individual points or predefined groups of selected points. Provide additional functionality to allow predefined groups of up to 250 trended points to be easily transferred online to Microsoft Excel.
 3. The following trend data provided for review by the commissioning agent:
 - a. Adequate trending data maintained to evaluate system performance and diagnose system problems. Controls Contractor is responsible for trending points necessary to evaluate controlled equipment. Controls Contractor to coordinate with the Cx regarding trend intervals and specific points to be trended. The following systems trended and trend data provided for review by the commissioning agent at 15-minute intervals unless otherwise directed.
 - b. Building electrical, chilled water flow,.
 - c. Monitored temperatures including but not limited to space, supply, return, outside air, mixed air, chilled water, heating water, steam, pumped condensate, and etc.
 - d. Occupancy modes as they apply to each piece of controlled equipment including but not limited to optimal start, occupied, unoccupied, temporarily occupied (override, etc.), night low limit, night high limit, night purge.
 - e. Motor run commands and motor proofs for fans and pumps.
 - f. VFD Speeds for controlled equipment.
 - g. Measured airflows for both air handlers and volume control units.
 - h. Damper positions for both air handlers and volume control units.
 - i. Cooling valve positions.

- j. Occupancy sensor indications used for HVAC control.
- k. Set points including but not limited to occupied and unoccupied space temperature, supply air temperature, hydronic supply temperature, radiant heating, and cooling temperature, pumping pressure, fan static pressure, etc.
- l. Supporting information necessary to evaluate setpoint reset sequences.
- m. Operating schedules for controlled equipment.
- n. Loop tuning variables.

2.9 APPLICATION PROGRAMS

- A. General: Provide user-programmable DDC system programs with library of base-level predefined functions with user specified parameters.
- B. Time of Day Scheduling:
 - 1. A minimum of six schedules provided for equipment operation.
 - 2. Seven unique days per schedule provided.
 - 3. Program individual time cycle capability for each piece of equipment.
- C. Control Priorities:
 - 1. Provide an effective order of control priorities such that each succeeding level of optimization does not interfere with a more critical function.
 - 2. Allow features as alarm actions and manual commands from the operator to override lower level functions (such as duty cycling or scheduling).
 - 3. Events, initiated outside the DDC system causing equipment shutdown automatically reset when events causing the shutdown is cleared, such as power failure or fire alarm. For alarms within the control system, mechanical equipment restart after the alarm condition is manually reset.
- D. Alarms: System provides following alarm processing capabilities:
 - 1. Connected status or analog point may be designated as alarm input point.
 - 2. Start/stop points with status feedback as well as associated analog alarms have user-programmable inhibit time assigned to each point to prevent nuisance alarms from occurring during startup of HVAC equipment.
 - 3. Each alarmable point have change-of-state priority assignment assignable at 3 levels. One each for its level of criticality: low for such things as maintenance alarms, high for critical HVAC equipment alarms, and emergency for life safety alarms.
 - 4. User may designate which conditions of alarm causes alarms to be initiated for display. The user may also designate alarm message for alarm condition and for return to normal condition as desired. Each message may be up to 32 characters in length and up to 32 messages are available in each digital management system.
 - 5. This feature provides for orderly display of alarms based on criticality; alarm with highest level of priority displayed first.
 - 6. User may designate which conditions of alarm causes alarms to be initiated for display. User may also designate alarm message for alarm condition and for return to normal condition as desired. Each message may be up to 80 characters in length.
 - 7. Provide automatic phone dialing feature with the capability to report a general alarm recorded message.
- E. Security: System supports multi-level password access with the following minimum access levels:
 - 1. Read-only level, without capability of changing any part of software.
 - 2. Adjustment level, allowing operator to adjust setpoints and schedules, force outputs on/off, but not to modify programming.

3. Full programming access.
 4. System supports additional levels of programming access.
- F. Power Failure:
1. In the event of the loss of normal power, there is an orderly shutdown of controllers to prevent the loss of database or operating system software.
 2. Non-volatile memory incorporated for critical controller configuration data, and battery backup provided to support the real-time clock and volatile memory for a minimum of 72 hours.
 - a. During a loss of normal power, the control sequences go to normal system shutdown conditions.
 - b. Upon restoration of normal power and after a minimum off-time delay, the controller automatically resumes full operation without manual intervention through a normal soft-start sequence.
 - c. Should a controller memory be lost for any reason, the operator workstation automatically reloads the program without any intervention by the system operators.
- G. Preventive maintenance software package.

2.10 INPUT/OUTPUT (I/O) FUNCTIONS

- A. Analog Inputs (AI):
1. AI function monitors each analog input, perform A-to-D conversion, and hold the digital value in a buffer for interrogation.
 2. Provide signal conditioning for each analog input.
 3. Individually calibrate analog inputs for zero and span, in hardware or in software.
 4. Minimum 12 bit A to D resolution.
- B. Analog Outputs (AO):
1. The AO function accepts digital data, perform D-to-A conversion, and output a signal compatible with the operator.
 2. Individually calibrate analog outputs for zero and span.
 3. Provide short circuit protection.
 4. Minimum 8 bit D to A resolution.
- C. Digital Inputs (DI):
1. DI function accepts ON/OFF, OPEN/CLOSE or other change of state (two-state data) indications.
 2. Provide isolation and protection against input voltage up to 180 Vac peak.
- D. Digital Outputs (DO):
1. DO function provides contact closures for momentary and maintained operation of output devices.
 2. Closures have a minimum duration of 0.1 second.

2.11 UNINTERRUPTABLE POWER SUPPLY (UPS)

- A. General:
1. Provide an uninterruptable power supply (UPS) for each DDC field panel.
 2. Fed by 120V AC emergency power circuits.
 3. Floor or wall mountable.
- B. UPS:
1. Provide MGE Pulsar UPS or pre-bid approved equal.

2. Products carry UL 1778 listing.
3. Base sizing on peak current requirements of connected load plus 15 percent factor of safety.
4. Provide manufacturer's standard three-year comprehensive warranty, including batteries.

2.12 ENERGY MANAGEMENT SYSTEM

- A. General:
 1. Provide a complete system consisting of metering instruments, communications between components; communications network; data loggers; protocol converters and other appurtenances as required for a complete system.
 2. Provide meters, network controllers, and Ethernet gateways with non-volatile flash memory sufficient to maintain system programming indefinitely.
- B. Data Acquisition Network:
 1. Connect meters to DDC system via TCP/IP communications over Ethernet LAN. Communications in BACnet/IP protocol.
 2. The system may utilize Modbus for communication with field devices over local RS-485 communications links.
 3. Connection to the building Ethernet network made at the nearest wall data outlet in a mechanical or electrical room.
 4. Limit cabling lengths between devices in accordance with manufacturers published requirements.
- C. Data Access and Display:
 1. Measured values, both instantaneous readings and historical data, available to users on any computer with an Internet connection without requiring a specific operating system or proprietary software that is not publically available freeware.
 2. Assign each metering a unique network address and by entering that address or corresponding URL into a web browser, HTML web pages of data available for that device.
 3. Specific browser software permitted to be required to access system features beyond the measured values.
- D. Data Format:
 1. The complete system synchronizes to a single time base so that events on the system can be compared at different locations on the system using a common time base. Time base synchronized with DDC system.
 2. Data stored in DDC system database.
- E. Software:
 1. Seamless BACnet/IP integrated with building Direct Digital Control, DDC system, and have the ability to display individual meter output data.
 2. Calculation engine to virtually calculate, display, and store-derived values.
 3. Minimum download meter data every 15 minutes.
- F. Interface and Display:
 1. Provide 32-inch LED flat panel display.
 2. Scroll through display features in 20 second intervals (adjustable).

3. Display:
 - a. Monthly Utility Total Energy (kbtu) and EUI (kbtu/sf/yr) bar chart overlaid with the prior year by month. Use different colors to indicate the contribution of gas and electricity to each monthly total bar.
 - b. Monthly System Total Energy (kbtu) and EUI (kbtu/sf/yr) bar chart overlaid with the prior year by month. Use different colors to indicate the contribution of each end use (Mechanical, plug loads, plumbing, and lighting) to each monthly total bar.
 - c. Current Day's end use energy demand (kW) overlaid with the annual weekday and weekend average demand (kW), and temperature in a line chart. Provide separate slides for Lighting and Plug Load end uses.
 - d. Current Day's end use energy demand (kbtu/hr) overlaid with the annual weekday and weekend average demand (kbtu/hr), and temperature in a line chart. Provide separate slides for Mechanical and Plumbing Load end uses.
 - e. Energy Meter Gauge indicating real-time end use energy demand (kW and W/sf) for Lighting and Plug Loads.
 - f. Energy use pie chart indicating percent of annual energy from each end uses (Mechanical, Plumbing, Plug Loads and Lighting).
 - g. Monthly water usage (gallons) and WUI (gallons/person/year) bar chart overlaid with the prior year by month.
- G. Current Sensors and Transformers:
 1. Current Transformers, 5 A:
 - a. Submetering:
 - 1) Accuracy: 1.0 percent (10 percent-100 percent of Current Transformer rating).
 - 2) Split-core: Flex-core, Hawkeye, Square-D, Veris.
 2. Current Sensors; 0-5 VDC, 330 milli-volt:
 - a. Submetering:
 - 1) Accuracy: 1.0 percent (10 percent-100 percent of Current Transformer rating).
 - 2) Manufacturers: Square-D, MagneLab, Veris, Sentron.
- H. Electrical Energy Meters:
 1. Measured values: Real kWh, Reactive kVARh, apparent kVAh, kW, power factor, RMS power, and current per phase.
 2. Voltage: monitored circuit voltage indicated in documents.
 3. Current Transformers: Provide milli-volt compatible meters where milli-volt Current Transformers are used.
 4. Minimum Current Transformer input amperage (5 Amp Current Transformer only): 10A.
 5. Sampling rate: minimum 3 kHz.
 6. Submetering Meter Accuracy: +/-1 percent accuracy (10 percent to 100 percent of Current Transformer rating).
 7. Manufacturers: Veris E50, Siemens, Square D.

PART 3 EXECUTION

3.1 INSTALLATION

- A. Operator Workstation: Locate as shown or submit proposed location where not shown.

- B. Mounting Panels: Locate panels where shown on Drawings or near item of equipment to be controlled, but not on equipment itself.
- C. DDC Field Panels: Provide number of panels required to accommodate DI, DO, AI, and AO points and hardware and software to accomplish specified control sequenced. Locate panels in mechanical or electrical rooms. Submit proposed locations for approval prior to preparing control drawings.
- D. Electrical:
 - 1. Provide control wiring for control devices and control panels.
 - 2. Run control wiring in mechanical rooms or locations susceptible to damage in conduit. Plenum rated cable may be used in other locations.
 - 3. Provide power wiring for control devices and control panels. Utilize designated circuits in electrical power panels. Refer to Electrical Drawings. If no circuits are designated for DDC Controls, submit detailed request for use of spare circuits at no additional cost.
 - 4. Install power wiring in conduit.
 - 5. Grounding: Instrumentation and communication grounding installed as necessary to preclude ground loops, noise, and surges from adversely affecting system operation.
 - 6. Control voltage limited to maximum of 120V.
 - 7. Where relay coil is connected to load side of motor starter to energize with motor operation, external control circuit properly fused with fuse block located in respective starter enclosure.
 - 8. Where relays are used to control single-phase motors directly, provide contacts rated for not less than horsepower rating of largest motor switched by relay.
- E. Identification: Provide engraved nameplates identifying switches, lights and starters, and each control device where control function is not readily apparent.
- F. Room Thermostats and Room Sensors:
 - 1. Wall Thermostats and Room Sensors with User Adjustment: Mount at height of 48-inches above finished floor.
 - 2. Provide insulating back on thermostats mounted on exterior walls.
 - 3. Provide one thermostat for each zone of temperature control.
 - 4. Submit proposed locations for approval prior to preparing control drawings, where not shown or alternate location is proposed.
- G. Carbon Dioxide Sensor:
 - 1. Mount sensor at 5 feet above finished floor or as indicated on the plans.
 - 2. Provide sensor quantity as indicated on plans or as required by sensor coverage rating (maximum 20-foot radius).
 - 3. Alarm above 850 ppm.
 - 4. Refer to sequence of operations for more information on sensor use.

3.2 ENERGY METERS

- A. System wiring configured such that any metering instrument can be isolated and removed from the system without the need to de-energize any power or protective circuit. This requirement may be met in one of two ways:
 - 1. Connections to the metering instrument may be made using separable terminal blocks. The terminal blocks for current transformer circuits short the current transformer circuit prior to breaking the metering instrument circuit on removal and makes the metering instrument circuit prior to unshorting the current transformer circuit on insertion. Current transformer and line voltage terminals finger safe when left disconnected and energized.

2. Connections to the metering instrument may be made through test blocks with disconnecting switches for line and neutral voltage circuits and shorting switches for current transformer circuits.
- B. System wiring within any switchgear of switchboard assembly Type SIS. Termination of Current Transformers in accordance with manufacturer's published requirements.
 - C. Provide overcurrent protection for metering equipment based on manufacturer's guidelines and the available fault current at the measurement point. This requirement may be met in one of three ways:
 1. Meter within 30-feet of Current Transformers:
 - a. Provide meter housing with integral fusing.
 - b. Provide circuit breaker or fused disconnecting means adjacent to equipment monitored.
 - c. Provide PT with integral fusing.
 2. Meter over 30 feet from Current Transformers:
 - a. Provide circuit breaker disconnect at equipment location for meter point and individual conductor fusing at meter equipment location.
 - D. Provide Current Transformers sized based on minimum circuit ampacity listed on equipment nameplate or circuit overcurrent protection device rating.
 - E. Provide Current Transformer conductors sized per manufacturer's published requirements based on length of run.
 - F. NEMA 1 housing unless noted otherwise. Located in a rooftop or exterior environment in NEMA 3R housing.
 - G. Provide additional NEMA enclosures as necessary for Current Transformers in order to provide manufacturer recommended clearances between separate Current Transformers.
 - H. Instrumentation calibrated based on National Institute of Standards and Technology, NIST, procedures.

END OF SECTION

SECTION 23 21 13
PIPE AND PIPE FITTINGS HVAC

PART 1 GENERAL

1.1 SUMMARY

- A. This Section includes:
 - 1. Black Steel Pipe Schedule 40
 - 2. Copper Pipe
 - 3. Flanged Joints
 - 4. Unions
 - 5. Mechanical Pipe Couplings and Fittings
 - 6. Soldering and Brazing

1.2 RELATED SECTIONS

- A. Division 01, General Requirements
- B. Division 23, Heating, Ventilating, and Air Conditioning (HVAC)
- C. Section 23 25 00, HVAC Water Treatment

1.3 QUALITY ASSURANCE

- A. Regulatory Requirements:
 - 1. Piping material and installation to meet requirements of the local building codes and serving utility requirements.
- B. Grooved joint couplings and fittings products of a single manufacturer. Grooving tools by the same manufacturer as the grooved components.
 - 1. Castings used for coupling housings, fittings, valve bodies, etc., date stamped for quality assurance and traceability.
- C. Pipe Cleaning: Should any pipe be plugged or should foaming of water systems occur, disconnect piping, re-clean, and reconnect without additional expense to the Owner.
- D. Correct damage to the building or systems resulting from failure to properly clean the system without additional expense to the Owner.

1.4 SUBMITTALS

- A. Submit the Following:
 - 1. List of piping materials indicating the service it is being used for. Do not submit piping product data.
 - 2. Product data on mechanical couplings and related components, double wall fuel oil pipe and fittings, and polypropylene waste and vent pipe.
 - 3. Certificate of completion
 - 4. Treatment Reports
 - 5. Radiant Floor Heating and Cooling Piping layout shop drawings.
 - 6. Radiant Floor Heating and Cooling Piping installation digital photographs.
- B. Test Reports and Certificates: Submit certificates of inspections and pipe tests to Owner.
- C. Other: Make certified welders' certificates available.

PART 2 PRODUCTS

2.1 MANUFACTURERS

- A. As indicated.

2.2 BLACK STEEL PIPE, SCHEDULE 40 AND STANDARD

- A. Pipe:
 - 1. Schedule 40 conforming to ASTM A 135 or A 53.
 - 2. Schedule 40 up to 10-inch diameter.
 - 3. Standard weight for 12-inch diameter and above.
- B. Fittings:
 - 1. 150 pound screwed malleable iron on 2 inches and below, Schedule 40 welding fittings conforming to ASTM A 234 for 2-1/2 inches and above or mechanical couplings on select piping as herein specified.
 - 2. Fittings Below Grade: Welding fittings.
 - 3. Long Radius Elbows: Pumped systems.
 - 4. Short Radius Elbows: Not acceptable for use except as approved on a case by case basis.
- C. Service:
 - 1. Chilled and Heating Water Piping (up to and including 6-inches)
 - 2. Chemical Treatment

2.3 COPPER PIPE

- A. Pipe: Hard drawn copper tubing, Class L, ASTM B 88.
- B. Fittings:
 - 1. Wrought copper, 150 psi; ANSI B16.22 for soldered joints, ANSI B16.50 for brazed joints; Chase, Revere, Mueller or approved equal.
- C. Service:
 - 1. Chilled water piping (Type L, hard drawn) up to and including 4-inches.
 - 2. Coil condensate drains and traps, cooling tower drains, and other miscellaneous drains.

2.4 FLANGED JOINTS

- A. Flanged Joints:
 - 1. Flanges:
 - a. Cast iron or steel for screwed piping and forged steel welding neck for welded line sizes.
 - b. In accordance with ANSI B16.1; 150 lb. for system pressures to 150 psig; 300 pounds for system pressures 150 psig to 400 psig.
 - 2. Pressure Rating and Drilling: Match apparatus, valve, or fitting to which they are attached.
 - 3. Gaskets:
 - a. Flanged Services: With the exception of steam and pumped condensate, Garlock 3700 or equal, 1/8-inch thick, non-metallic type.
 - b. Steam and Pumped Condensate: Flexitaucic Style CG or equal, 1/8-inch thick, semi-metallic type.
 - 4. Make joint using American Standard hexagon head bolts, lock washers, and nuts (per ASTM A307 GR.B) for service pressures to 150 psig; alloy steel stud bolts, lock washer, and American Standard hexagon head nuts (per ASTM A307 GR.B) for service pressures 150 psig to 400 psig.
 - 5. Use length of bolt required for full nut engagement.
 - 6. Provide electro-cad plated bolts and nuts on cold and chilled water lines.

2.5 UNIONS

- A. 150 psi malleable iron, brass to iron seat, ground joint, black or galvanized to match pipe. 200 psi WOG bronze, ground joint, solder type for copper tubing.
- B. Dielectric Fittings:
 - 1. Nationally listed, have a dielectric thermoplastic interior lining, and meet requirements of ASTM F1545.
 - 2. Suitable for the pressure and temperature to be encountered.

2.6 MECHANICAL PIPE COUPLINGS AND FITTINGS

- A. Acceptable Manufacturers:
 - 1. Victaulic
 - 2. Other Manufacturers: Submit substitution request.
- B. Couplings: Ductile iron conforming to ASTM A 536, Grade 65-45-12, rust inhibiting paint.
- C. Fittings:
 - 1. Ductile iron conforming to ASTM A 536, Grade 65-45-12.
 - 2. Long radius elbows.
- D. Bolts and Nuts: Zinc electroplated track head bolts conforming to ASTM A 183.
- E. Gasket: Grade E EPDM:
 - 1. Temperature Range: -30 degrees F to 230 degrees F.
 - 2. Flushseal, Installation Ready or Flush Gap configuration.
- F. Service:
 - 1. Chilled Water

2.7 SOLDERING AND BRAZING

- A. Brazed Joints:
 - 1. Westinghouse Phos-Copper or Dyna-Flow by J.W. Harris Co., Inc.
 - 2. Applied locations:
 - a. Above grade piping larger than 2-inches for the following services: chilled water.
- B. Soldered Joints:
 - 1. Wrought Copper Pipe Fittings: All-State 430 with Duzall Flux, Engelhard Silvabrite with Engelhard General Purpose Flux or J.W. Harris Co.
 - 2. Valves, Cast Fittings or Bronze Fittings: Harris Stay-Silv-15 or Handy & Harmon Sil-Fos.
 - 3. Applied locations: Above grade piping 2-inch and smaller for the following services: chilled water.
- C. Valves, Cast Fittings or Bronze Fittings: Harris Stay-Silv-15 or Handy & Harmon Sil-Fos.

PART 3 EXECUTION

3.1 PREPARATION

- A. Measurements, Lines and Levels:
 - 1. Check dimension at the building site and establish lines and levels for work specified in this Section.
 - 2. Establish inverts, slopes, and manhole elevations by instrument, working from an established datum point. Provide elevation markers for use in determining slopes and elevations in accordance with Drawings and Specifications.

3. Use established grid and area lines for locating trenches in relation to building and boundaries.

3.2 PIPING INSTALLATION

- A. Install unions in non-flanged piping connections to apparatus and adjacent to screwed control valves, traps, and appurtenances requiring removal for servicing so located that piping may be disconnected without disturbing the general system.
- B. Mechanical Pipe Couplings and Fittings:
 1. Grooved joint couplings, fittings, valves, and specialties products of a single manufacturer. Grooving tools of the same manufacturer as the grooved components.
 2. Flexible couplings to be used only when expansion, contraction, deflection or noise and vibration is to be dampened, as detailed or specified.
 3. On systems using galvanized pipe and fittings, fittings galvanized at factory.
 4. Before assembly of couplings, lightly coat pipe ends and outside of gaskets with approved lubricant.
 5. Pipe grooving in accordance with manufacturer's specifications contained in latest published literature.
 6. Mold and produce gaskets by coupling manufacturer, and suitable for the intended service.
 7. Coupling manufacturer's factory trained representative to provide on-site training for the contractor's field personnel in the use of grooving tools and installation of grooved joint products. Periodically visit the project site to ensure best practices in grooved installation are being followed (a distributor's representative is not considered qualified to conduct the training or field visits).

3.3 PIPING JOINTS

- A. Pipe and Fittings:
 1. Join using methods and materials recommended by manufacturer in conformance with standard practice and applicable codes.
 2. Cleaning, cutting, reaming, grooving, etc. done with proper tools and equipment.
 3. Hacksaw pipe cutting prohibited.
 4. Peening of welds to stop leaks not permitted.
- B. Copper Piping:
 1. Pipe cut evenly with cutter, ream to full inside diameter; end of pipe and inside of fitting thoroughly cleaned and polished.
 2. Joints uniformly heated, and capillary space completely filled with solder or braze material, leaving full bead around entire circumference.
- C. No couplings installed in floor or wall sleeves.
- D. Steel Piping:
 1. Screwed Joints:
 - a. Pipes cut evenly with pipe cutter reamed to full inside diameter with burrs and cuttings removed.
 - b. Joints made up with suitable lubricant or Teflon tape applied to male threads only, leaving two threads bare.
 - c. Tightened so that not more than two threads are left showing.
 - d. Junctions between galvanized steel waste pipe and bell of cast iron pipe made with tapped spigot or half coupling on steel pipe to form spigot end and caulked.

2. Flanged Joints:
 - a. Pressure rating of flanges to match valve or fitting joined.
 - b. Coat joint gaskets with graphite and oil.
- E. Welded Joints:
 1. Preparation for Welding: Bevel piping on both ends before welding:
 - a. Use following weld spacing on butt welds:

Nominal Pipe Wall Thickness	Spacing	Bevel
1/4-inch or less	1/8-inch	37-1/2
Over 1/4-inch, less than 3/4-inch	3/16-inch	27-1/2
 - b. Before welding, remove corrosion products and foreign material from surfaces.
 2. Welded Joints:
 - a. Arc weld joints using certified welders.
 - b. Port openings of fittings must match the inside diameter of the pipe to which they are welded.
 - c. Use full radius welding elbows for turns, use welding tees for tees.
 - d. Reducing fittings must be used for size reduction.
 - e. Weldolets may be used for branches up through one-half the pipe size of the main to which they are attached.
 - f. Nipples are not allowed.
 3. Welding Operation:
 - a. After deposition, clean each layer of weld metal to remove slag and scale by wire brushing or grinding. Chip where necessary to prepare for proper deposition of next layer.
 - b. Weld reinforcement no less than 1/16-inch not more than 1/8-inch above normal surface of jointed sections. Reinforcement crowned at center and taper on each side to surfaces being joined. Exposed surface of weld present professional appearance and be free of depressions below surface of jointed members.
 - c. Do not weld when temperature of base metal is lower than 0 degrees F. Material to be welded during freezing temperatures made warm and dry before welding is started. Metal warm to the hand or approximately 60 degrees F.
- F. Screwed Joints: Use Teflon tape or Teflon liquid dope applied to male threads only.
- G. Flexible Couplings: Provide where indicated on the Drawings.

3.4 ADJUSTING AND CLEANING

- A. General:
 1. Clean interior of piping before installation.
 2. Flush sediment out of piping systems after installation before connecting mechanical equipment to the piping.
 3. When placing the water systems in service during construction, each system cleaned by circulating a solution with 1000 ppm of trisodium phosphate for 24 hours, then drained, flushed and placed in service.
 4. Clean strainers prior to placing in service.

END OF SECTION

SECTION 23 21 23
PUMPS FOR HVAC SYSTEMS

PART 1 GENERAL

1.1 SUMMARY

- A. This Section includes:
 - 1. Base Mounted Centrifugal Pumps

1.2 RELATED SECTIONS

- A. Division 01, General Requirements
- B. Division 23, Heating, Ventilating, and Air Conditioning (HVAC)

1.3 QUALITY ASSURANCE

- A. Select pump impellers such that impellers shall not be greater than minimum impeller size plus 90 percent of the difference between the maximum and minimum impeller size for pump selected.
- B. Select motor to be non-overloading under all operating conditions.
- C. Select pump with a minimum efficiency as listed in schedule.
- D. Provide couplings and seals suitable for application (including temperature, pH, glycol solution concentration, and loads over full range of pump operation).
- E. Pumps and motors with flexible couplers shall be factory aligned, and realigned by manufacturer's representative after installation.

1.4 SUBMITTALS

- A. Submit the following:
 - 1. Product data for each pump including performance curves, pump efficiency, motor data, operating weights, and pressure ratings.
 - 2. Submit control information and wiring diagrams for packaged equipment.
 - 3. Operating and maintenance data for each product specified under this Section.
 - 4. Detailed shop drawings.
 - 5. Installation instructions.

PART 2 PRODUCTS

2.1 MANUFACTURERS

- A. Base Mounted Centrifugal Pumps:
 - 1. Paco
 - 2. Bell and Gossett
 - 3. Taco
 - 4. Other Manufacturers: Submit Substitution Request.

2.2 BASE MOUNTED CENTRIFUGAL PUMPS

- A. Description: End suction centrifugal pump, motor, flexible coupling drive mounted on a common steel baseplate.
- B. Components:
 - 1. Vertical split case construction, cast iron volute, bronze fitted.
 - 2. 175 psig working pressure unless otherwise noted.
 - 3. Enclosed type, single stage, bronze impeller.
 - 4. Mechanical shaft seal, regreasable ball bearings.
 - 5. Motor: 1750 rpm maximum speed.

6. Coupling drive and guard.
7. Steel baseplate with open grouting area.
8. Pump internals capable of being serviced without disturbing piping.
9. Capacity head and power requirements as scheduled on Drawings.

PART 3 EXECUTION

3.1 BASE MOUNTED CENTRIFUGAL PUMP INSTALLATION

- A. Install pump in location shown in accordance with manufacturer's written installation instructions.
- B. Install on inertia base.
- C. Provide flexible connections, strainers, check valves and shutoff valves on suction, and discharge as shown on Drawings.
- D. Lubricate in accordance with manufacturer's instructions before operation.
- E. Support interconnecting piping independently of pump and inertia base to prevent stresses from being transmitted to the casings.

END OF SECTION

SECTION 23 25 00
HVAC WATER TREATMENT

PART 1 GENERAL

1.1 SUMMARY

- A. Closed Loop Systems

1.2 RELATED SECTIONS

- A. Division 01, General Requirements

1.3 SUBMITTALS

- A. Submit the following:
 - 1. Shop drawings.
 - 2. Product data.
 - 3. Operating and maintenance data.
 - 4. Certificate of completion.
 - 5. Treatment reports.

PART 2 PRODUCTS

2.1 MANUFACTURER

- A. US Water Services
- B. Nalco
- C. Mogul
- D. Chemax
- E. Chemcoa
- F. DuBois Chemicals
- G. Industrial Treatment of Water
- H. Other Manufacturer/Suppliers: Submit substitution request.

2.2 CLOSED LOOP SYSTEMS

- A. Chemicals:
 - 1. 75 ounces of Nalco 39 per 100 gallons of water, or Mogul 7174 borate nitrite of required dosage. Filling may be through bypass shot feeder across pump.
 - 2. Final system treatment achieves 800-1200ppm Sodium Nitrite in the system water. Apply tolyltriazole levels of minimum 3ppm in closed loop water.
- B. One Shot Feeder:
 - 1. Description: Furnish and install one-shot chemical bypass feeders on each closed loop system where water treatment is specified.
 - 2. Construction:
 - a. 2 quart, 4 quart, 10 quart, or maximum of 5 gallon volume as required to initially treat the system served in two shots.
 - b. Pressure Rating: 150 psig or 300 psig to match other valve and pressure vessel ratings.
 - c. Provide fill funnel and valve, air vent cock and drain valve and plug.
- C. Glycol Mixing Tank:
 - 1. Tank: 50 gallon, 90 mil polyethylene tank with 1/3 hinged PE cover. Fully support and restrain tank with painted carbon steel frame.

2. Control Panel: NEMA 4X control panel with 115V power cord. Panel to include:
 - a. 2 position main power switch and light.
 - b. 3 position (hand/off/auto) switch and light for gear pump.
 - c. Red low level light and dry contact for connection of alarm to the DDC system.
 - d. 15A fuse.
 - e. Audible alarm and silence switch.
3. Low Level Switch: Polypropylene side entry low level switch with 10 amp relay.
4. Gear Pump:
 - a. 1/3 HP gear pump to provide steady and even flow of 1.5GPM at 100psi discharge pressure.
 - b. Pump to have flooded suction with bronze ball valve, flexible rubbering, and cast iron Y-Strainer.
 - c. Pump discharge to have flexible discharge tubing, brass check valve, copper piping, and 1/4-inch NPT back tap pressure gauge.
5. Pressure Switch: 1/4-inch NPT pressure switch with cut-in range of 10-45psi, cut out range of 20-50psi and psi difference of 10-30.
6. Pressure Relief Valve: 5-300psi brass pressure relief valve.
7. Manufacturer:
 - a. J.L. Wingert Co. Model GL50-E1 economy glycol feed system.
 - b. Or as approved.

PART 3 EXECUTION

3.1 INSTALLATION

- A. HVAC Closed Loop Systems:
 1. Install shot feeders across pump or appropriate restricting valve with adequate mounting to prevent piping damage and preclude transmitting vibration to structure.
 2. Filling may be through bypass shot feeder across pump.
 3. Final system treatment achieves 800-1200ppm Sodium Nitrite in the system water. Apply tolyltriazole levels of minimum 3ppm in closed loop water.
 4. Test to confirm proper inhibitor levels.
 5. Install glycol mixing tank according to manufacturer's recommendations to provide scheduled concentration of glycol.
 6. Install corrosion coupon rack per manufacturer's recommendations around the supply and return side of circulating pump. Install isolation valves at each side of rack within easy reach of operator.

3.2 FINAL ADJUSTMENT

- A. When the systems are accepted by the Owner the chemical treatment supplier to make final adjustments in the required concentrations.
- B. Submit report of indicating initials and final concentrations and system chemistry.
- C. Furnish sufficient chemicals to constitute one years supply for systems.

END OF SECTION

SECTION 23 64 00
PACKAGED WATER CHILLERS

PART 1 GENERAL

1.1 SUMMARY

- A. This Section includes:
 - 1. Air Cooled Water Chiller

1.2 RELATED SECTIONS

- A. Division 01, General Requirements
- B. Division 23, Heating, Ventilating, and Air Conditioning (HVAC)
- C. Section 23 05 48, Vibration and Seismic Control for HVAC Piping and Equipment
- D. Section 23 09 00, Instrumentation and Controls for HVAC

1.3 SUBMITTALS

- A. Submit the following:
 - 1. Shop Drawings showing complete details of construction.
 - 2. Catalog data showing performance data.
 - 3. Part load operating characteristics: both the integrated part load value (IPLV), and non-standard part load value (NPLV) calculation per AHRI Standard 550/590.
 - 4. Operating and Maintenance Data

PART 2 PRODUCTS

2.1 MANUFACTURERS

- A. Air Cooled Water Chiller:
 - 1. Carrier
 - 2. Air-cooled chiller has been pre-purchased by OSU directly to include the following:
 - a. Chiller and associated trim, panels, transformers, disconnects and controls.
 - b. Delivery to OSU.
 - c. Startup and 1st year warranty.
 - d. Travel to jobsite for startup.
 - e. BACnet controls integration.
 - f. Extended 2-10 year parts and labor warranty.

2.2 AIR COOLED WATER CHILLER

- A. Description:
 - 1. Complete packaged air cooled screw water chiller, consisting of compressors, air-cooled condensers, refrigerant piping and specialties, and controls, contained on a common frame.
 - 2. Provide one-piece integral unit.
 - 3. Fully charge unit with refrigerant at factory.
 - 4. Construct in accordance with ANSI B9.1 Safety Code for Mechanical Refrigeration.
 - 5. Contain wiring and piping within unit enclosure.
 - 6. Mount electrical components in a rain-tight enclosure.
 - 7. Exterior sheet metal, galvanized steel, with an electro-statically applied baked enamel finish.

- B. Compressor:
 - 1. screw compressor with variable speed capacity control.
 - 2. Positive displacement oil pump. Suction and discharge service valve.
 - 3. Electric actuated, cylinder head unloading or slide valve.
 - 4. Removable crankcase opening, with crankcase heater in crankcase well.
- C. Motor:
 - 1. Continuous duty induction type to match compressor torque curves, cooled by full flow of suction gas and suitable for voltage fluctuation of plus or minus 10 percent of nameplate voltage.
 - 2. Provide solid state sensor in each motor winding to protect against excess winding temperatures.
- D. Evaporator:
 - 1. Shell and tube design with seamless copper tubes expanded into tube sheets and removable heads for mechanical tube cleaning.
 - 2. Test and stamp units in accordance with ASME Code for Unfired Pressure Vessels for refrigerant side working pressure of 225 psig and water side working pressure of 150 psig.
 - 3. Provide water manifold package for single supply and return water connections.
- E. Air-Cooled Condensers:
 - 1. Unit circuited to provide subcooling.
 - 2. Condensers constructed of 1/2-inch OD seamless copper tubes with mechanically bonded aluminum fins, leak tested at 150 psig, pressure tested at 450 psig.
- F. Condenser Fans and Motors: Provide direct-drive, propeller type condenser fans, with steel wire safety guards and 3-phase, permanently lubricated and inherently protected fan motors with corrosion resistant fan shaft.
- G. Head Pressure Control: Provide head pressure control system. Cycled condenser fans by a combination of discharge pressure and ambient temperature to permit operation to 40 degrees F outdoor ambient temperature.
- H. Electrical Enclosure: Short circuit current rating a minimum of 65kA in accordance with UL Standard 508.
- I. Refrigerant Circuit Accessories: Provide required refrigeration accessories, including condenser liquid line valves, combination filter-dryers, solenoid liquid stop valves, liquid line sight glasses, expansion valves and discharge valve on compressors.
- J. Insulation: Factory insulate evaporator including heads and cold refrigerant piping, and condenser including head, with 3/4-inch expanded polyvinyl chloride (K = 0.26) over heaters to protect against freezing.
- K. Wiring: Field wiring to consist of single point electrical connection to chiller and 115V control interlock wiring to pumps and flow switches. Provide terminals.
- L. Startup provided under the direct supervision of the manufacturer's representative with factory trained personnel.
- M. Control Panel: Unit equipped with control panel utilizing 120V, single phase power supply from transformer in starter and containing following microprocessor based accessories and features:
 - 1. Display of evaporator/condenser refrigerant pressures, oil pressure, return/leaving chilled water temperature, return/leaving condenser water temperatures, evaporator/condenser refrigerant temperatures, compressor discharge temperature, oil temperature.

2. Programming of setpoints through keypad and include leaving chilled water temperature, percent current demand, and remote reset temperature range.
 3. Safety controls annunciated through alpha-numeric display and include high/low oil pressure, high/low refrigerant pressure, low chilled water temperature, starter faults, low flow through evaporator /condenser, high oil temperature, high compressor discharge temperature, high motor temperature.
 4. Battery back-up for control panel with circuit protection from high voltage and power surge conditions.
 5. Choice of control modes from hand/off/auto.
 6. Extra contact to annunciate machine failure to remote area and extra contact for safety shutdown from external source.
 7. Pilot relays to start chilled water pumps.
 8. Time limit control to limit starts to one in 30 minutes.
 9. Provide BACnet card for serial communication with Building Management System.
- N. Capacity Control:
1. Electronic thermostat and controller to modulate capacity of machine to maintain constant (plus or minus 0.5 degree F) chilled water supply temperature.
 2. Chilled water temperature setpoint to be remotely adjustable from building control system.
 3. Coordinate requirements with Section 23 09 00, Instrumentation and Controls for HVAC.
 4. Machine modulates to within 20 percent capacity without using hot gas bypass per ARI 550 requirements.
- O. Starter: Variable Frequency Drive (VFD), Unit Mounted:
1. Factory mounted on the chiller and shipped completely factory assembled, wired and tested.
 2. Specifically designed to interface with the chiller controls and allow for the operating ranges and specific characteristics of the chiller. Control logic optimizes chiller efficiency. If a surge is detected, VFD surge avoidance logic will make adjustments to move away from and avoid surge at similar conditions in the future.
 3. Solid state, microprocessor based pulse width modulated (PWM) design, voltage and current regulated. IGBT transistor output power device.
 4. Furnish in NEMA 4 metal enclosure having as minimum a short circuit withstand rating of 65,000A per UL 508. It will include three phase input lugs plus a grounding lug for electrical connections, output motor connection via factory installed bus bars and components properly segregated and completely enclosed in a single metal enclosure.
 - a. Enclosure includes padlockable, door-mounted circuit breaker with shunt trip and AIC rating of 65,000A.
 - b. Entire chiller package UL/CUL listed.
 5. Test to ANSI/UL Standard 508 and list by a Nationally Recognized Testing Laboratory (NRTL) as designated by OSHA.
 6. Compliance to recommendations stated in IEEE 519-1992.
 - a. VFD design includes as standard integrated active rectification control system to limit total demand distortion (TDD) in current at the VFD to less than 5-percent.
 7. Line frequency 38-60 hertz.

8. The following VFD status indicators available to facilitate startup and maintenance.
 - a. Output frequency in hertz and rpm
 - b. Input line voltage
 - c. Input line kW
 - d. Output/load amps
 - e. Average current in percent RLA
 - f. Load power factor
 - g. Fault
 - h. VFD transistor temperature
9. Service Conditions – at full output power. No external venting or heat exchangers required.
 - a. Operating ambient temperature 32 degrees F-104 degrees F
 - b. Elevation to 3300-feet.
 - c. For every 300-feet above 3300-feet, decrease the rated output current by 1 percent.
- P. Disconnect: Provide chiller with a circuit breaker or fused disconnect rated for a minimum of 65kA SCCR in accordance with UL 508.
- Q. Refrigerants: Allowable refrigerants are as follows:
 1. R-123
 2. R-134a
 3. R-410A
- R. Performance:
 1. As indicated on drawings.
 2. Certified per ARI 550/590-98.
 3. Based on 0.0001 fouling factors for evaporator.

PART 3 EXECUTION

3.1 INSTALLATION

- A. General: Comply with manufacturer's instructions for installation. Prior to beginning work, contractor to coordinate with Owner a phasing plan for installation of new chiller, pumps, piping and accessories with demolition of existing chiller, pumps, piping and accessories as well as rental chiller disconnection to confirm scheduling, logistics and all other related items for approval.
- B. Support structure: Install chiller on existing structural piers. Provide W8x24 continuous spreader steel framing and vibration isolation for chiller base connection to structural piers.
- C. Pipe Connections: Arrange connections to chiller to prevent pipe weight or stresses from being transferred to chiller and to provide easy access for tube cleaning.
- D. Auxiliary Water Piping:
 1. Provide piping as required for water supply lines and branch connections to oil cooler, purge system and bearings.
 2. Provide waste connection piping to nearest open sight drain.
- E. Refrigerant Relief Vents: Pipe rupture disc or refrigerant relief valve discharge from each chiller separately to the outside of the building.
- F. Water Treatment: Treat chilled and condenser water system as specified.

3.2 START UP

- A. General: Comply with manufacturer's instructions for startup.
- B. Start up provided under the direct supervision of the manufacturer's representative with factory trained personnel.

3.3 FIELD QUALITY CONTROL

- A. Prior to installation, manufacturer's representative coordinate chiller control interface and verify that intended installation (controls, piping, etc.) complies with the manufacturer's recommendations.
- B. Field Test:
 - 1. Except where initial chiller operation clearly shows the performance meets or exceeds the requirements, test to show compliance.
 - 2. Tests performed by the manufacturer's representative in the presence of the Engineer.

END OF SECTION

SECTION 23 82 00
CONVECTION HEATING AND COOLING UNITS

PART 1 GENERAL

1.1 SUMMARY

- A. This Section includes:
 - 1. Cooling Coils, Water
 - 2. Fan Coil Units

1.2 RELATED SECTIONS

- A. Division 01, General Requirements
- B. Division 23, Heating, Ventilating, and Air Conditioning (HVAC)

1.3 SUBMITTALS

- A. Submit the following:
 - 1. Catalog data showing dimensions and performance.
 - 2. Computer calculations for coil performance.
 - 3. Operation and Maintenance Data: Fan coil units.

PART 2 PRODUCTS

2.1 MANUFACTURERS

- 1. Cooling Coils, Water:
 - a. Pace
 - b. Trane
 - c. McQuay
 - d. Carrier
 - e. Colmac
 - f. Dunham-Bush
 - g. York
 - h. Heatcraft
 - i. SFI
 - j. Other Manufacturers: Submit substitution request.
- 2. Fan Coil Units:
 - a. Trane
 - b. Carrier
 - c. McQuay
 - d. International
 - e. Air Therm
 - f. York
 - g. Other Manufacturers: Submit substitution request.

2.2 COOLING COILS, WATER

- A. Coils of nonferrous extended surface construction with continuous 16 gauge galvanized steel casing for installation in air supply unit or ductwork as shown on Drawings.
- B. Primary surface of 5/8" seamless copper tubing rolled into headers with copper bushings or brazed into nonferrous headers.

- C. Fins: Nonferrous, mechanically bonded to tubes, with fin spacing of 12 fins per inch maximum.
- D. Coils tested at 450 psi hydrostatic pressure, guaranteed for 250 psi working pressure.
- E. Arranged for serpentine flow in continuous circuits with counterflow between air and water without turbulating means; provide air vents at each coil.
- F. Supply and return connections on same side, with supply on bottom, downstream of air flow.
- G. 0.008-inch minimum fin thickness; 0.024-inch minimum tube wall thickness; 0.035-inch straight stock for U-turns.
- H. Capacity certified in accordance with ARI Standard 410-72. Face velocity not to exceed 500 fpm at specified air flow.

2.3 FAN COIL UNITS

- A. Description:
 - 1. Furnish complete unit including cabinet, fan and motor assembly, heating coil, cooling coil, and filter.
 - 2. Unit UL approved for application and wired per NEC.
- B. Cabinet:
 - 1. 18 gauge steel, welded, and bolted construction, removable panels for access to components.
 - 2. Interior portions of cabinet insulated to prevent condensation.
 - 3. Factory applied baked enamel finish.
- C. Fans and Motor: Steel construction designed for minimum noise levels, direct drive type, multispeed permanent split capacitor motor or belt drive unit, fan controls.
- D. Filters: Throwaway type, 1-inch thick fiberglass.
- E. Electric Heating Coils:
 - 1. Integral with unit including magnetic contactors and automatic controls.
 - 2. Furnish transformer for a single point electrical connection.
 - 3. Refer to Section 23 09 00, Instrumentation and Controls for HVAC.
- F. Water Coils:
 - 1. 3/4-inch OD seamless copper tubes, aluminum fins, and end supports.
 - 2. Provide shutoff valves on water lines, and unions for a complete system.
 - 3. 250 psi working pressure.
- G. Drain Pan:
 - 1. Galvanized steel drain pan with copper drain connection.
 - 2. Pan to extend under coil and coil connection for proper drainage of condensate.
- H. Configuration: Horizontal unit, integral return air grille, ducted outlet connection.
- I. Controls: Configure unit for field installation of DDC control panel and sensors as follows:
 - 1. Valves, actuators, and space temperature sensor will be furnished under Section 23 09 00, Instrumentation and Controls for HVAC for field installation.
 - 2. Refer to Section 23 09 93, Sequence of Operations for HVAC Controls. For additional information on required controls, control functions, and sequences of operation for both field and factory-installed controls.
- J. Speed Controller: Provide three-speed switch mounted on side of unit.
- K. Electrical: Furnish magnetic contactors. Arrange for single point electrical connection. Provide field wiring.

PART 3 EXECUTION

3.1 INSTALLATION

- A. Cooling Coils: Installed in air handling units as standard with manufacturer or in ductwork as shown.
- B.
- C. Fan Coil Units:
 - 1. General: Install per manufacturer's instructions.
 - 2. Suspension:
 - a. Suspend from structure with suitable rods or brackets.
 - b. Refer to Drawings and Section 23 05 48, Vibration and Seismic Controls for HVAC Piping and Equipment, for vibration isolation and seismic bracing requirement.
 - 3. Provide valves and specialties as detailed on the Drawings.

END OF SECTION

SECTION 26 05 00
COMMON WORK RESULTS FOR ELECTRICAL

PART 1 GENERAL

1.1 SUMMARY

- A. The intent of Division 26, Electrical Specifications and Drawings is to provide a complete and workable facility, with complete systems as required by applicable codes, as indicated, and as specified.
- B. Include work specified in Division 26, Electrical and as indicated on Drawings. Include appurtenances, connections, fasteners, and accessories required to make a complete working system, whether indicated or not indicated.
- C. Refer to Division 01, General Requirements.

1.2 RELATED SECTIONS

- A. Division 01, General Requirements
- B. Division 26, Electrical

1.3 REFERENCES

- A. The latest adopted revisions of the publications listed below apply to these Specifications as referenced:
 - 1. IBC International Building Code
 - 2. NEC National Electrical Code
 - 3. NFPA National Fire Protection Association
 - 4. NEMA National Electrical Manufacturers Association
 - 5. NECA National Electrical Contractors Association
 - 6. ANSI American National Standards Institute
 - 7. IEEE Institute of Electrical and Electronic Engineers
 - 8. UL Underwriters Laboratories

1.4 SYSTEM DESCRIPTION

- A. Ground Systems:
 - 1. Provide complete ground systems indicated.
 - 2. Include conduit system, motors, and miscellaneous grounds required by Contract Documents and by applicable codes.
- B. System Identification:
 - 1. Clearly identify elements of the Project electrical system to indicate the loads served, or the function of each item of equipment, connected under this work.
 - 2. Comply with requirements of Division 26, Electrical, and with applicable codes.
- C. Drawings:
 - 1. Drawings are diagrammatic. They do not show every offset, bend, tee, or elbow, which may be required to install work in the space, provided and avoid conflicts with other construction.
 - a. Prior to installing work, take field dimensions, and note conditions available for, installation.
 - b. Follow the Drawings as closely as practical to do so, and install additional bends, offsets, and elbows where required by installation conditions.
 - 1) Additional offsets, bends, and other connectors are subject to approval by Project Engineer.

- 2) Install additional offsets, bends, and other connectors without additional cost to Owner.
- c. The right to make any reasonable changes in outlet location prior to roughing in is reserved to the Owner's Representative.
- d. Circuits and Switching:
 - 1) Do not change branch circuiting and switching indicated; nor combine homeruns, without Engineer's prior approval.
 - 2) Do not combine or change feeder runs.
2. Circuit Conductors:
 - a. Cross or hash marks on conduit runs indicate quantity of No. 12 copper branch circuit conductors, unless otherwise noted.
 - b. Where such marks do not appear, provide quantity of circuit conductors to the outlets shown to perform the control or circuiting indicated.
 - c. Include ground, travelers, and switch legs required by the circuiting arrangement indicated.
 - d. Provide a dedicated neutral conductor with each circuit. Do not use a shared neutral conductor between phases unless, requested or directed.

1.5 SUBMITTALS

- A. Comply with Division 01, General Requirements.
- B. Contractor Responsibilities:
 1. Submit submittals one time and in proper order.
 2. Ensure equipment will fit in the space provided.
 3. Deviations from the Drawings and Specifications specifically noted in the submittals. Failure to comply will automatically void any implied approval for use of the equipment on this project.
- C. Shop Drawings and Equipment Data:
 1. Combine electrical shop drawings and equipment data together in electronic format.
 2. Include in electronic submission:
 - a. Complete index of materials and equipment as required by Specifications to be documented by submittals.
 - b. Fully describe equipment furnish per manufacturer's detailed specifications.
 - c. All deviations from the Drawings and Specifications, noted on the submittals. Failure to comply will automatically void any implied approval for use of the equipment on this project.
- D. Installation Drawings:
 1. Submit prior to starting installation.
 2. Show outlets, devices, terminal cabinets, conduits, wiring, and connections required for the complete system described.
- E. Record Drawings:
 1. Keep record drawings up to date as the work progresses.
 2. Show changes, deviations, addendum items, change orders, corrections, and other variations from the Contract Drawings.
 3. Keep record drawings at the jobsite and available for the Engineer's review.
 4. At the completion of the work, incorporate all deviations from the installation drawings to indicate as-built conditions.

- F. Operation and Maintenance Data:
1. As specified in Division 01, General Requirements.
 2. Provide a separate manual or chapter for each system as follows:
 - a. Low Voltage Distribution System
 3. Description of system.
 4. Operating Sequence and Procedures:
 - a. Step-by-step procedure for system start-up, including a pre-start checklist.
 - 1) Refer to controls and indicators by nomenclature consistent with that used on panels and in control diagrams.
 - b. Detailed instruction in proper sequence, for each mode of operation (i.e., day-night, staging of equipment).
 - c. Shutdown Procedure:
 - 1) Include instructions for stopping and securing the equipment after operation.
 - 2) If a particular sequence is required, give step-by-step instructions in that order.
 5. Preventive Maintenance:
 - a. Schedule for preventive maintenance.
 - 1) State the recommended frequency of performance of each preventive maintenance task such as cleaning, inspection, and scheduled overhauls.
 - b. Cleaning: Provide instructions and schedules for all routine cleaning and inspection with recommended lubricants.
 - c. Inspection: If periodic inspection of equipment is required for operation, cleaning, or other reasons, indicate the items to be inspected and give the inspection criteria.
 - d. Provide instructions for lubrication and adjustments required for preventive maintenance routines. Identify test points and given values for each.
 6. Manufacturers' Brochures:
 - a. Include manufacturers' descriptive literature covering devices and equipment used in the system, together with illustrations, exploded views, and renewal parts lists.
 - b. Clearly define manufacturers' standard brochures so that the information applying to the actual installed equipment.
 7. Results of performance testing, as specified in PART 3 of this Section.
- G. Submittals Procedures:
1. Recommendations by the Owner or Engineer are not to be construed as change authorizations.
 2. Either if discrepancies are discovered between the materials or equipment submitted, and the Contract Documents, prior to or after the data is processed, the Contract Documents govern.

1.6 QUALITY ASSURANCE

- A. Regulatory Requirements:
 - 1. Products and equipment comply with Oregon Revised Statute (ORS) 453.005(7)(e) prohibiting pentabrominated, octabrominated, and decabrominated diphenyl ethers. Where products or equipment within this specification contains these banned substances, provide complying products and equipment from approved manufacturers with equal performance characteristics.
 - 2. Provide work and materials conforming to:
 - a. Local and State codes.
 - b. Federal and State laws and regulations.
 - c. Other applicable laws and regulations.
 - 3. Obtain and pay for all permits, licenses, and inspection certificates required by authorities having jurisdiction.
 - 4. Pay any other fees required by governing authorities for work of this Division.
- B. Install only electrical products listed by a recognized testing laboratory, or approved in writing by the local inspection authority as required by governing codes and ordinances.

1.7 SITE VISITATION

- A. Visit the site prior to bidding and become familiar with existing conditions and other factors which may affect the execution of the work. Complete coordination of installation of equipment with prior bid packages previously issued. Include related costs in the initial bid proposal.

1.8 COORDINATION

- A. Coordinate Work of This Division with all other trades to ensure proper installation of electrical equipment.
 - 1. Review Drawings of other trades or crafts to avoid conflicts with equipment, structural members, and other possible impediments to electrical work.
 - 2. Report potential conflicts to the Engineer prior to rough-in.
 - 3. Proceed with rough-in following Engineer's directives to resolve conflicts.
- B. Verify the physical dimension of each item of electrical equipment to fit the available space. Contractor's responsibility includes:
 - 1. Coordination of the equipment to fit into the available space.
 - 2. Access routes through the construction.
- C. Layout Drawings:
 - 1. Equipment arrangement shown on Drawings is diagrammatic to indicate general equipment sizing and spatial relationship. Include, as part of distribution equipment submittal, a scaled floor plan, which includes equipment shown with their submitted sizes. Include all feeder conduit routing and termination points at equipment. Submit for Engineer's review prior to commencing work.
 - 2. Provide additional wiring details at switchboards, motor control centers, and other areas where work is of sufficient complexity to warrant additional detailing for coordination.
 - 3. Submit layout drawings for approval prior to commencing field installation.
- D. Where electrical connections are required for equipment provided as Work of other Divisions, coordinate rough in and wiring requirements for that equipment with its supplier and installer prior to commencing work. Notify Owner and Engineer of any discrepancies between the actual rough in and wiring requirements, and those identified on Drawings for resolution prior to installation.

- E. Arrange raceways, wiring, and equipment to permit ready access to switches, motors, and control components.
 - 1. Keep doors and access panels clear.
- F. Coordinated Shop Drawings.
 - 1. Prepare in two-dimensional format.
 - 2. Include but are not limited to:
 - a. Superplot plans of above ground work with a colored overlay of all trades including, but not limited to, HVAC piping, HVAC equipment, plumbing piping and equipment, sprinklers, and electrical power conduit to a minimum of 1/2-inch equals 1-foot scale.

1.9 CHANGE ORDERS

- A. Supplemental cost proposals by the Contractor accompanied with a complete itemized breakdown of labor and materials. At the Architect's request, make available estimating sheets for the supplemental cost proposals. Separate and allocate labor for each item of work.

1.10 WARRANTY

- A. Provide a written warranty covering the work of this Division as required by the General Conditions.
- B. Apparatus:
 - 1. Free of defects of material and workmanship and in accord with the Contract Documents.
 - 2. Built and installed to deliver its full rated capacity at the efficiency for which it was designed.
 - 3. Operate at full capacity without objectionable noise or vibration.
- C. Include in Contractor's warranty for Work of Division 26, Electrical system damage caused by failures of any system component.

PART 2 PRODUCTS

2.1 GENERAL

- A. Where specified materials or methods conflict with applicable codes, the more stringent requirement applies.
- B. Provide apparatus built and installed to deliver its full rated capacity at the efficiency for which it was designed.
- C. Ensure that entire electrical system operates at full capacity without objectionable noise or vibration.
- D. Materials and Equipment:
 - 1. Use materials and equipment that are:
 - a. New
 - b. Quality meeting or exceeding specified standards.
 - c. Free of faults and defects.
 - d. Conforming to Contract Documents.
 - e. Of size, make, type, and quality specified.
 - f. Suitable for the installation indicated.
 - g. Manufactured in accordance with NEMA, ANSI, UL, or other applicable standards.
 - 2. Equipment not meeting all requirements will not be acceptable, even though specified by name.

3. Where two or more units of the same class of equipment are furnished, use products of the same manufacturer.
 - a. Component parts of the entire system need not be products of same manufacturer.
4. Basis of Design:
 - a. Consider the Basis of Design equipment scheduled or specified by performance or model number.
 - b. If other equipment is provided in lieu of the Basis of Design equipment, assume responsibility for all changes and costs which may be necessary to accommodate this equipment, including, but not limited to:
 - 1) Different sizes and locations for connections.
 - 2) Different dimensions.
 - 3) Different access requirements.
 - 4) Other differences.
5. Safety
 - a. It is important that the design meet requirements of all appropriate codes, standards and guidelines, including, but not limited to, the following codes and regulations: State and local, UL, NEC, NESC, NFPA, NEMA, NECA, ASHRAE, ISESNA, IEEE, ANSI, ADA, IBC, and OSHA. It is also important that all the equipment, devices and installations supplied and installed in all University's Facilities meet high level of safety requirements, and the OSU Construction Standards. It shall also be known that the equipment, devices, and installation that fail to meet these requirements will not be accepted.
6. Prohibited Materials and Construction Practices
 - a. Extra flexible non-labeled conduit or non UL listed conduit.
 - b. Plastic conduit for interior electrical use, except that PVC conduit may be used for power circuits below basement concrete floors in corrosive environments, and for ground wires in any location, or with approval from the OSU FS Electrical Shop. The transition from PVC to steel shall be made below the floor.
 - c. Aluminum wiring/bussing shall not be used.
 - d. Use of incompatible Materials: Aluminum fittings and boxes shall not be used with steel conduit. All materials in a raceway system shall be compatible.
 - e. Use of wire ties to support conduit.
 - f. Electrical ducts crossing above gas piping.
 - g. Hard insulated wire connectors, which have Bakelite, are prohibited.
 - h. Nonmetallic sheathed cable.
 - i. Powder metal die cast connectors, fittings, and couplings.
 - j. Locating equipment that requires access or ventilation less than four (4) feet from a wall, fence, or other screening material, including but not limited to, electrical equipment that permits or requires cooling; access for maintenance or cleaning, connection; and main distribution panels and equipment.
 - k. Bottom fed switches, breakers, or fuses.
 - l. Switches in which the blades pivot on the top.
 - m. Switches, breakers, etc. that require greater than 75 pounds of force on the operating handle.
 - n. Drilling or tapping of existing bussing in panel boards, switchboards, and motor control center. All spare spaces/motor buckets will have bus-ties installed.

- o. Use of a bushing without a lock nut.
- p. Use of communication cable tray to support power and lighting circuits/raceway.
- q. 15A wiring devices unless required by the NEC or specific equipment.
- r. Use of gray wire on 208Y/120 volt systems. Use of white wire on 480Y/277 volt systems.
- s. Metal conduit covers supported by a threaded body for outdoor use in corrosive environments.
- t. Piercing, push-in, or WACL type splices or connections.
- u. Without UL approval, the tapping of existing switchgear, switchboards, panel boards, and motor control centers to provide power for new feeders or equipment is prohibited in all University Facilities.
- v. Sharing motor circuits with power receptacles.
- w. Panel enclosures and junction boxes larger than 4 11/16 that have stamped knock-outs.
- x. Crimp connectors, except butt-splice.
- y. Flexible conduit of any type used in interior partitions or in walls as a substitute for EMT, IMC, or rigid steel conduit.

PART 3 EXECUTION

3.1 INSTALLATION

- A. General:
 - 1. Provide a complete, properly operating system for each item of equipment specified.
 - 2. Install materials in a neat and professional manner.
 - 3. Comply with equipment manufacturer's written instructions, the best industry practices, and the Contract Documents.
 - 4. Comply with latest published NECA Standard of Installation, and provide competent supervision.
 - 5. Contractor(s), Designers, and Engineer(s) are responsible for addressing all the design review comments to the satisfaction of OSU authorized representatives in order to assure the continued reliability of the University power distribution system.
 - 6. Copies of all electrical permits and inspections, including final inspection, shall be given to the OSU Project Manager and the OSU FS Electric Shop within ten (10) days of receipt.
 - 7. No exceptions to Construction Standards without written approval from specific shop.
 - 8. All plans/drawings shall have the OSU Construction Standards version listed in the lower right hand side of plan/drawing.
- B. Clarification:
 - 1. Where there is a conflict among manufacturer's instruction, best practice, and the Documents, request clarification from the Architect prior to rough-in.
 - 2. Engineer's decision will be final.
 - 3. Remove and correct work installed without clarification at no cost to the Owner.
- C. Existing concrete, block, or brick walls are considered not accessible and may require use of Surface Mounted Raceway (SMR) if existing concealed raceway and device boxes are not available for reuse or do not meet the intent of the design (i.e., proximity to egress path, point of use, etc.). Coordinate route and installation where SMR is required with the Architect/Engineer prior to rough-in. Responsible for reinstalling SMR routed without such prior approval to the Architect's satisfaction.

- D. Existing stud walls (wood or metal) with or without blocking with plaster, plasterboard, or paneling finish are considered accessible with accessible ceiling, attic, tunnel, or crawl space above, below, or adjacent. Remove, patch, and repair finished surface as required to conceal rough in for new device locations. If it is determined that a specific instance will not permit concealment of rough-in due to obstructions such as beams, headers, and other structural elements, prior approval before rough-in from the Architect is required.

3.2 INSTALLATION IN RATED CONSTRUCTION

- A. Install intumescent material around ducts, conduits, and other electrical elements penetrating rated construction.
- B. Comply with firestop materials manufacturer written instructions to prevent spread of smoke or fire through sleeves or block-outs penetrating rated fire barriers.
- C. Provide firestop materials as follows:
 - 1. Capable of passing a 3-hour test per ASTM E-814 (UL 1479).
 - 2. Consisting of material capable of expanding nominally eight times when exposed to temperatures of 250 degrees F-350 degrees F.
 - 3. An alternate method utilizing intumescent materials in caulk or putty complying with Division 07, Thermal and Moisture Protection Section, "Through-Penetration Firestop Systems" may be used.

3.3 NOISE CONTROL

- A. Minimize transmission of noise between occupied spaces.
- B. Outlet Boxes:
 - 1. Do not install outlet boxes on opposite sides of partitions back to back.
 - 2. Do not use straight through outlet boxes, except where indicated.
- C. Conduit:
 - 1. Route conduit along corridors or other "noncritical" space to minimize penetrations through sound rated walls, or through non-sound-rated partitions between occupied spaces.
 - 2. Grout solid and airtight all penetrations through sound rated partitions.
 - 3. Use flexible connections or attachments between independent wall structures.
 - a. Do not rigidly connect (i.e., bridge) independent wall structures.
- D. Do not install contactors, transformers, starters, and similar noise-producing devices on walls that are common to occupied spaces, unless otherwise indicated.
 - 1. Where such devices are indicated to be mounted on walls common to occupied spaces, use shock mounts, or otherwise isolate them to prevent the transmission of noise to the occupied spaces.
- E. Contactors, starters, transformers, and like equipment which are found to be noticeably noisier than other similar equipment on the project will be deemed defective and shall be replaced.

3.4 EQUIPMENT CONNECTIONS

- A. General:
 - 1. Provide complete electrical connections for all items of equipment requiring such connections, including incidental wiring, materials, devices, and labor necessary for a finished working installation.
 - 2. Verify the location and method for connecting to each item of equipment prior to roughing-in.
 - 3. Check the amperage, maximum overcurrent protection, voltage, phase, and similar attributes of each item of equipment before rough in and connection.

- B. Motor Connections:
 - 1. Make motor connections for the proper direction of rotation.
 - 2. Minimum Size Flex for Mechanical Equipment: 1/2-inch; except at small control devices where 3/8-inch flex may be used.
 - 3. Exposed Motor Wiring: Jacketed metallic flex with minimum 6-inches slack loop.
 - 4. Do not test run pump motors until liquid is in the system.
- C. Control devices and wiring relating to the HVAC systems are furnished and installed under Division 23, HVAC; except for provisions or items indicated in Division 26, Electrical Drawings and Specifications.

3.5 EQUIPMENT SUPPORT

- A. Minimum Support Capacity:
 - 1. Provide fastening devices and supports for electrical equipment, luminaires, panels, outlets, and cabinets capable of supporting not less than four times the ultimate weight of the object or objects fastened to or suspended from the building structure.
- B. Luminaire Supports:
 - 1. Support luminaires from the building structure.
 - 2. Use supports that provide proper alignment and leveling of luminaires.
 - 3. Where permitted at exposed luminaires, install flexible connections neat and straight, without excess slack, and attached to the support device.
- C. Support all junction boxes, pull boxes, or other conduit terminating housings located above the suspended ceiling from the floor above, roof, or penthouse floor structure to prevent sagging or swaying.
- D. Conduits:
 - 1. Support suspended conduits 1-inch and larger from the overhead structural system with metal ring or trapeze hangers and threaded steel rod having a safety factor of four.
 - 2. Conduits smaller than 1-inch installed in ceiling cavities, may be supported on the mechanical system supports when available space and support capacity has been coordinated with the subcontractor installing the supports.
 - 3. Anchor conduit installed in poured concrete to the steel reinforcing with No. 14 black iron wire.
- E. Powder actuated or similar shot-in fastening devices will not be permitted for any electrical work except by special permission from the Architect.

3.6 ACCESS DOORS

- A. Location and size of access doors is Work of Division 26, Electrical.
- B. Furnishing and installation of access doors is work of Division 08, Openings.

3.7 ALIGNMENT

- A. Install panels, cabinets, and equipment level and plumb, parallel with structural building lines.
- B. Install distribution equipment and electrical enclosures fitted neatly, without gaps, openings, or distortion.
- C. Properly and neatly, close unused openings with approved devices.
- D. Fit surface panels, devices, and outlets with neat, appropriate, trims, plates, or covers without overhanging edges, protruding corners, or raw edges.

3.8 CUTTING AND PATCHING

- A. General:
 - 1. Comply with Division 01, General Requirements.
 - 2. Restore to original condition new or existing work cut or damaged by installation, testing, and removal of electrical Work.
 - 3. Patch and finish spaces around conduits passing through floors and walls to match the adjacent construction, including painting or other finishes.
 - 4. Clean up and remove all dirt and debris.
- B. Make additional required openings by drilling or cutting. Use of jackhammer is prohibited.
- C. Cut oversize fill holes so that a tight fit is obtained around the objects passing through.
 - 1. In rated construction, comply with Division 07, Thermal and Moisture Protection.
- D. Obtain Architect's permission and direction prior to piercing beams or columns.
- E. Where alterations disturb lawns, paving, walks, and other permanent site improvements, repair and refinish surfaces to condition existing prior to commencement of work.

3.9 PROTECTION OF WORK

- A. Protect electrical work and equipment installed under this Division against damage by other trades, weather conditions, or any other causes.
 - 1. Equipment found damaged or in other than new condition will be rejected as defective.
- B. Keep switchgear, transformers, panels, luminaires, and electrical equipment covered or closed to exclude dust, dirt, and splashes of plaster, cement, paint, or other construction material spray.
 - 1. Equipment not free of contamination is not acceptable.
- C. Provide enclosures and trims in new condition, free of rust, scratches, and other finish defects.
 - 1. If damaged, properly refinish in a manner acceptable to the Architect.

3.10 UNINTERRUPTED SERVICE

- A. Maintain electrical service to all functioning portions of the building throughout construction.
- B. Pre-arrange with Owner outages necessary for new construction.
 - 1. Comply with Division 01, General Requirements.
 - 2. Apply for scheduled shutdowns minimum 4 weeks prior to time needed and reconfirm a minimum of 72 hours prior to time needed.
 - 3. Contractor is liable for any damages resulting from unscheduled outages or for those not confined to the pre-arranged times. Damages include costs incurred by the Owner and by the Owner's tenants.
- C. Maintain signal and communication systems and equipment in operation at all times.
 - 1. Outages of these systems shall be treated the same as electrical power outages.
- D. Maintain telephone services in accordance with Division 01, General Requirements.

3.11 DEMOLITION AND SALVAGE

- A. General:
 - 1. Remove or relocate all electrical wiring, equipment, luminaires, etc., as may be encountered in removed or remodeled areas in the existing construction affected by this work.
 - 2. Disconnect electrical service to hard-wired equipment scheduled for removal under other Divisions of Work.

3. Wiring which serves usable existing outlets restored and routed clear of the construction or demolition.
 4. Safely cut off and terminate wiring abandoned and removed to leave site clean.
- B. Reuse of Existing:
1. Existing concealed conduits in good condition may be reused for installation of new wiring where available.
 2. Existing undamaged, properly supported surface conduits may be reused where surface conduits are called for, if the installation meets all workmanship requirements of the Specifications.
 3. Where new wiring is added or existing wiring disturbed in existing branch circuit raceways, existing wires replaced with new.
- C. Salvage and Disposal:
1. Removed materials, not containing hazardous waste, not scheduled for reuse shall become the property of the Contractor for removal from the site, except for those items specifically indicated on the Demolition Drawings for salvage or reuse.
 2. Materials containing, or possibly containing, hazardous waste identified for removal and disposal by the Owner's Hazardous Waste Contractor.
 3. Neatly store salvaged items at one location at the site where directed by the Owner's Representative.
 4. Salvage properly operating circuit breakers from panels scheduled for removal and use to replace faulty or inadequate breakers in existing panels scheduled to remain.

3.12 COMPLETION AND TESTING

- A. General:
1. Comply with Division 01, General Requirements.
- B. Upon completion, test systems to show that installed equipment operates as designed and specified, free of faults and unintentional grounds.
1. Schedule system tests so that several occur on the same day.
 2. Coordinate testing schedule with construction phasing.
 3. Conduct tests in the presence of the Architect or its representative.
 4. Notify Architect of tests 48 hours in advance.
- C. Engage a journeyman electrician with required tools to conduct equipment tests. Arrange to have the equipment factory representative present for those tests where the manufacturer's warranty could be impacted by the absence of a factory representative.
- D. Perform tests per the requirements of each of the following systems:
1. Low Voltage Distribution System
- E. Provide a written record of performance tests and submit with operation and maintenance data.

END OF SECTION

SECTION 26 05 19

LOW VOLTAGE ELECTRICAL POWER CONDUCTORS AND CABLES

PART 1 GENERAL

1.1 SUMMARY

- A. This Section includes:
 - 1. Conductors - 600V
 - 2. Connectors - 600V and Below

1.2 RELATED SECTIONS

- A. Division 01, General Requirements
- B. Division 26, Electrical
- C. Section 26 05 26, Grounding and Bonding for Electrical Systems
- D. Section 26 05 33, Raceways and Boxes for Electrical Systems
- E. Section 26 05 53, Identification for Electrical Systems
- F. Section 26 05 80, Electrical Testing

1.3 REFERENCED STANDARDS

- A. ASTM: American Society For Testing and Materials:
 - 1. ASTM B 3 Soft or Annealed Copper Wire
 - 2. ASTM B 8 Concentric-Lay-Stranded Copper Conductors, Hard, Medium-Hard, or Soft
 - 3. ASTM B 33 Tinned Soft or Annealed Copper Wire for Electrical Purposes
- B. ICEA: Insulated Cable Engineers Association:
 - 1. S-95-658 Non-shielded 0-2 kV Cables
- C. IEEE: Institute of Electrical and Electronic Engineers:
 - 1. IEEE 383 Type Test of Class IE Electric Cables, Field Splices, and Connections
- D. UL: Underwriters Laboratories:
 - 1. UL 44 Rubber-Insulated Wires and Cables
 - 2. UL 83 Thermoplastic-Insulated Wires and Cables
 - 3. UL 1277 Type TC Power and Control Tray Cable

1.4 SUBMITTALS

- A. Submit product data for the following materials:
 - 1. Single conductor 600V power and control conductors.
- B. Submittals of the following materials consist only of a listing of the manufacturer's name and the applicable catalog numbers of the items to be utilized.
 - 1. Connectors
 - 2. Branch Circuit Conductor Splices
 - 3. Splices with Compression Fitting and Heat-Shrinkable Insulator
- C. Submit cable test data per testing requirements of PART 3.

1.5 QUALITY ASSURANCE

- A. Copper Conductors. Indicated sizes considered minimum for ampacities and voltage drop requirements.
- B. Conductors for special systems as recommended by the equipment manufacturer except as noted.

- C. Deliver conductors to the job site in cartons, protective covers, or on reels.

PART 2 PRODUCTS

2.1 MANUFACTURERS

- A. Conductors - 600V:
 - 1. General
 - 2. Essex
 - 3. Southwire
 - 4. Or equivalent.
- B. Connectors - 600V and Below:
 - 1. Burndy
 - 2. Anderson
 - 3. Or equivalent.

2.2 CONDUCTORS – 600V

- A. Type:
 - 1. Copper: 12 AWG minimum size unless noted otherwise. 12 AWG and 10 AWG, solid or stranded, 8 AWG or larger, Class B concentric or compressed stranded.
 - a. 98% Conductivity
 - 2. Aluminum: Not allowed.
 - 3. Conductors with continuous colored jackets are acceptable; refer to color-coding in PART 3.
 - 4. Conductors with manufacturers no lube continuous jacket coatings are acceptable.
 - 5. Field installed cords to portable equipment shall be Type ST or SO and field installed cords for normal equipment shall be Type SRDT or SPT-3.
- B. Insulation:
 - 1. THHN/THWN-2 for conductors 6 AWG and smaller.
 - 2. XHHW-2 for conductors 4 AWG and larger.
- C. Thru wiring in fluorescent luminaires rated for 90 degree C minimum.

2.3 CONNECTORS – 600V AND BELOW

- A. Branch Circuit Conductor Splices:
 - 1. Live spring type, Scotchlok, Ideal Wire Nut, Buchanan B-Cap, or 3M Series 560 self-stripping type.
- B. Cable Splices:
 - 1. Compression tool applied sleeves, Kearney, Burndy, or equivalent with 600V heat shrink insulation.
 - 2. Submit proposed splice location to the Engineer for review, except where indicated on the plans
- C. Terminator Lugs for Stranded Wire:
 - 1. 10 AWG Wire and Smaller: Spade flared, tool applied.
 - 2. 8 AWG Wire and Larger: Compression tool applied.
 - 3. Setscrew type terminator lugs furnished as an integral part of distribution equipment, switches and circuit breakers will be acceptable.

PART 3 EXECUTION

3.1 CONDUCTORS

- A. Pulling compounds may be used for pulling conductors. Clean residue from the conductors and raceway entrances after the pull is made.
- B. Pulleys or Blocks:
 - 1. Use for alignment of the conductors when pulling.
 - 2. Pulling in accordance with manufacturer's specifications regarding pulling tensions, bending radii of the cable, and compounds.
- C. Make up and insulate wiring promptly after installation of conductors. Do not pull wire in until bushings are installed and raceways terminations are completed. Do not pull wire into conduit embedded in concrete until after the concrete poured and forms stripped.
- D. Provide a dedicated neutral conductor with each branch circuit, do not use a shared neutral conductor between phases unless specifically requested or directed.
- E. For remodel work or where shared neutrals are used by equipment such as systems furniture, provide a breaker handle tie as required for the phases sharing the neutral conductor.
- F. Any cable, including signal, communication, and low-voltage wiring, pulled in a raceway on grade or below shall be rated for wet locations.

3.2 CONNECTORS

- A. Terminate control and special systems with a tool applied spade flared lug when terminating at a screw connection.
- B. Screw and bolt type connectors made up tight and retightened after an 8 hour period.
- C. Apply tool applied compression connectors per manufacturer's recommendations and physically checked for tightness.
- D. Connections in No. 10 and smaller wire shall be made with threaded-on plastic or nylon insulated wire nuts. Crimp connectors, except butt connectors are prohibited. Joints in No. 8 and larger conductors shall be made with pre-insulated mechanical lugs.

3.3 COLOR CODING

- A. Color code secondary service, feeders, and branch circuit conductors. Phase color code to be consistent at feeder terminations, A-B-C left-to-right, A-B-C top-to-bottom, or A-B-C front-to-back. Color code is as follows:

120/240V 208Y/120V	Phase	480V 480Y/277V
Black	A	Brown
Red	B	Orange
Blue	C	Yellow
White	Neutral	Gray*
Green	Ground**	Green
* or white with colored (other than green) tracer		
**Ground for isolated ground receptacles green with yellow tracer.		

- B. Use solid color compound or solid color coating for 12 AWG and 10 AWG branch circuit conductors and neutral sizes.
- C. Phase conductors 8 AWG and larger color code using one of the following:
 - 1. Solid color compound or solid color coating.
 - 2. Stripes, bands, or hash marks of color specified above.

3. Colored as specified using 3/4-inch wide tape. Apply tape in half overlapping turns for a minimum of three inches for terminal points and in junction boxes, pull boxes, troughs, manholes, and handholes. Apply the last two laps of tape with no tension to prevent possible unwinding. Apply tags to cable stating size and insulation type where cable markings are tape covered.
- D. Switch legs, travelers, etc., consistent with the phases to which, connected or a color distinctive from that listed.
- E. Color-coding of the flexible wiring system conductors and connectors.
- F. For modifications and additions to existing wiring systems, color-coding conform to the existing wiring system.

3.4 FIELD TESTING

- A. 600V Rated Conductors: Test for continuity. Conductors 100A and over in meggered after installation and prior to termination. Provide the megger, rated 1,000V DC, and record and maintain the results, in tabular form, clearly identifying each conductor tested.
 1. Replace cables when test value is less than 1 megohms.
 2. Cable test submittal include results, equipment used, and date.

END OF SECTION

SECTION 26 05 26
GROUNDING AND BONDING FOR ELECTRICAL SYSTEMS

PART 1 GENERAL

1.1 SUMMARY

- A. This Section includes:
 - 1. Ground Conductors
 - 2. Connectors

1.2 RELATED SECTIONS

- A. Division 01, General Requirements
- B. Division 26, Electrical
- C. Section 26 05 19, Low Voltage Electrical Power Conductors and Cables
- D. Section 26 05 33, Raceways and Boxes for Electrical Systems
- E. Section 26 05 80, Electrical Testing

1.3 QUALITY ASSURANCE

- A. Provide complete ground systems as indicated. Include conduit system, motors, and miscellaneous grounds required.
- B. Provide an insulated ground conductor in every conduit or raceway containing power conductors.
- C. Continue existing system as specified herein and shown on the Drawings.

PART 2 PRODUCTS

2.1 GROUND CONDUCTORS

- A. Green insulated copper for use in conduits, raceways, and enclosures.
- B. Bare copper for ground grids and grounding electrode systems.

2.2 CONNECTORS

- A. Cast, set screw, or bolted type.
- B. Form poured, exothermic welds.
- C. Grounding lugs where provided as standard manufacturer's items on equipment.

PART 3 EXECUTION

3.1 INSTALLATION

- A. Grounding Conductors: Sized in accordance with Article 250, Tables 250.66 and 250.122 of the National Electrical Code.
 - 1. A wire equipment ground shall be installed within the branch circuit conduit and be grounded to the cabinet of the panel board to an uninsulated ground bus. The neutral bar of the panel shall not be used for equipment grounds.
- B. Grounding Conductor Connectors: Make up tight, located for future servicing, and ensure low impedance.
- C. Plug-in Receptacles: Bonded to the boxes, raceways, and grounding conductor.

3.2 EQUIPMENT

- A. Provide separate green insulated equipment ground conductor in non-metallic and flexible electrical raceways.
- B. Ground luminaires, panels, controls, motors, disconnect switches, exterior lighting standards, and noncurrent carrying metallic enclosures. Use bonding jumpers, grounding bushings, lugs, buses, etc., for this purpose.

- C. Provide grounding bushings on feeder conduit entrances to panels and equipment enclosures and bond bushings to enclosures with minimum 10 AWG conductor. Connect the equipment ground to the building system ground. Use the same size equipment ground conductors as phase conductors, up through 10 AWG.

3.3 GROUND RESISTANCE TEST

- A. Accomplish with a ground resistance direct-reading single test meter utilizing the Fall-of-Potential method and two reference electrodes. Perform test prior to interconnection to other grounding systems. Orient the concrete-encased ground electrode to be tested and the two reference electrodes in straight-line spaced 50-feet apart. Drive the two reference electrodes 5-feet deep.
- B. Provide test results writing.
 - 1. Show temperature, humidity, and condition of the soil at the time of the tests.
 - 2. Where the ground resistance exceeds 5 Ohms, the Engineer will issue additional instructions.

END OF SECTION

SECTION 26 05 29
HANGERS AND SUPPORTS FOR ELECTRICAL SYSTEMS

PART 1 GENERAL

1.1 SUMMARY

- A. This Section includes:
 - 1. Hangers
 - 2. Pipe Straps

1.2 RELATED SECTIONS

- A. Division 01, General Requirements
- B. Division 26, Electrical
- C. Section 26 05 33, Raceways and Boxes for Electrical Systems

1.3 REFERENCED STANDARDS

- A. International Building Code (IBC)
- B. Sheet Metal and Air Conditioning Contractors' National Association (SMACNA)

PART 2 PRODUCTS

2.1 HANGERS

- A. Kindorf B-905-2A Channel, H-119-D washer, C105 strap, minimum 1/2-inch rod with ceiling flange, or equal.

2.2 PIPE STRAPS

- A. Two-hole galvanized or malleable iron.

PART 3 EXECUTION

3.1 INSTALLATION

- A. Provide electrical equipment supports.
- B. Install vertical support members for equipment, straight and parallel to building walls.
- C. Provide independent supports to structural member for electrical fixtures, materials, or equipment installed in or on ceiling, walls, or in void spaces and/or over furred or suspended ceilings.
- D. Do not use other trades' fastening devices to support electrical equipment materials or fixtures.
- E. Do not use supports and/or fastening devices to support other than one particular item.
- F. Support conduits within 18-inches of outlets, boxes, panels, cabinets, and deflections.
- G. Provide complete seismic anchorage and bracing for the vertical and lateral restraint of conduit, cable trays, bus ducts, and electrical equipment as required by IBC Chapter 6 and the most recent version of the SMACNA Seismic Restraint Manual for Seismic Hazard Level (SHL) A. Submit shop drawings of bracing systems to the Architect for review and bear the seal of a professional engineer registered in the State of Oregon.

3.2 PULL AND JUNCTION BOXES

- A. Pull and junction boxes installed within the cavity of a suspended ceiling that is not a fire rated assembly may be attached to the suspended ceiling framing members, provided the following criteria are met:
 - 1. Installation complies with the ceiling system manufacturer's instructions.
 - 2. Pull or junction box is not larger than 100 cubic inches.
 - 3. Support to the main runner with two fastening devices designed for framing member application and positively attach or lock to the member.

4. Serves branch circuits and associated equipment in the area.
5. Pull or junction box is within 6-feet of the luminaires supplied.
6. Framing members are not rotated more than 2 degrees after installation.
7. Install within the cavity of a suspended ceiling may be attached to independent support wires, provided the following criteria are met:
 - a. Independent support wires are taut and connected at both ends, one end to the ceiling framing member and the other to the structure above.
 - b. No larger than 100 cubic inches.
 - c. Secure to the independent support wires by two fastening devices designed for the application.
 - d. Independent support wires in a fire-rated ceiling are distinguishable by color, tagging, or other effective means.

3.3 CABLES AND RACEWAY

- A. Cables and raceway installed within the cavity of a suspended ceiling may be attached to independent support wires provided the following criteria are met:
 1. Independent support wires are taut and connected at both ends, one end to the ceiling framing member and the other to the structure above.
 2. Raceways no larger than 1-inch trade size and cables and bundled cables are not larger than 1-inch diameter including insulation.
 3. Not more than three raceways or cables supported by independent support wire and supported within the top or bottom 12-inches.
 4. Cables for telecommunications, data processing, Class 2 power-limited signaling systems, fiber optics, and other power limited systems are securely fastened within 2 feet of each termination and at intervals not to exceed 5-feet or per the manufacturer's installation instructions.
 5. Secure raceways at intervals required for the type of raceway installed.
 6. Secure cables and raceway to independent support wires by fastening devices and clips designed for the purpose.
 7. Independent support wires are distinguishable by color, tagging, or other effective means.
- B. Cables and raceway installed within the cavity of a suspended ceiling may be supported with trapezes constructed of steel rods and channels provided the following criteria are met:
 1. The size of the rods, channel, and fastening devices are suitable for the anticipated weight.
 2. The spacing of the trapezes meets that required for the type of raceway installed.
 3. Secure to a trapeze by straps designed for the purpose.
 4. Cables and raceway do not support other raceway or cables.
 5. An appropriately sized seismic bracing system is installed.

END OF SECTION

SECTION 26 05 33
RACEWAYS AND BOXES FOR ELECTRICAL SYSTEMS

PART 1 GENERAL

1.1 SUMMARY

- A. This Section includes:
 - 1. Metallic Conduits
 - 2. Fittings
 - 3. Metallic Boxes

1.2 RELATED SECTIONS

- A. Division 01, General Requirements
- B. Division 26, Electrical
- C. Section 26 05 19, Low Voltage Electrical Power Conductors and Cables
- D. Section 26 05 26, Grounding and Bonding for Electrical Systems
- E. Section 26 05 29, Hangers and Supports for Electrical Systems
- F. Section 26 05 53, Identification for Electrical Systems

PART 2 PRODUCTS

2.1 GENERAL

- A. Raceways and conduits of specified types for electrical system wiring, except where clearly indicated otherwise.
- B. Fittings, boxes, hangers, and appurtenances required for the conduits and raceways.
- C. Size raceways and conduits as indicated. Where no size indicated, conduit may be the minimum code permitted size for the quantity of conductors installed, based upon NEC tables for conductors with type THW insulation.

2.2 METALLIC CONDUITS

- A. Rigid Metal Conduit (RMC):
 - 1. Smooth surfaced heavy wall mild steel tube of uniform thickness and temper, reamed and threaded at each end and protected inside and out with galvanizing, sherardizing, or equivalent process.
 - 2. Comply with NEC Article 344.
- B. Intermediate Metallic Conduit (IMC):
 - 1. Smooth surface, intermediate wall mild steel tube of uniform thickness and temper, reamed and threaded at each end, and protected inside and out with galvanizing, sherardizing, or equivalent process.
 - 2. Comply with NEC Article 342.
- C. Electrical Metallic Tubing (EMT):
 - 1. Smooth surface, thin wall mild steel tube of uniform thickness and temper, galvanized or sherardized on the outside, and enameled on the interior.
 - 2. Comply with NEC Article 358.
- D. Flexible Conduits (Flex):
 - 1. Flexible Metallic Conduit:
 - a. Interlocking single strip steel construction, galvanized inside and out after fabrication.
 - b. Comply with NEC Article 348.

2. Liquid Tight:
 - a. Similar to flexible metallic conduit, except encased in a liquid tight polyvinylchloride or equivalent outer jacket over the flexible steel core.
 - b. Comply with NEC Article 350.

2.3 FITTINGS

- A. RMC and IMC:
 1. Threaded Locknuts: Sealing type where used with NEMA 2, 3, 3R, 4, and 12 enclosures.
 2. Threaded Bushings: 1-1/4-inch and larger, insulated, grounding type as required under Section 26 05 26, Grounding and Bonding for Electrical Systems.
 3. Threaded Couplings:
 - a. Standard threaded of the same material and as furnished with conduit supplied.
 - b. Erickson type couplings may be used where required to complete conduit runs larger than 1-inch.
- B. EMT:
 1. Connectors:
 - a. Steel compression ring or steel set screw type for conduit termination, with insulated throat, suitable for conditions used.
 - b. Use lay-in grounding type bushings where terminating grounding conductors.
 2. Couplings: Steel compression ring or steel set screw type, concrete tight.
- C. Threadless: RMC and IMC couplings and box connectors may be steel threadless, compression ring or set screw type for use with conduits 1-inch and smaller where installed in poured concrete locations or where limited working space makes threaded fittings impractical.
- D. Weatherproof Connectors: Threaded
- E. Expansion Couplings: Equivalent to O.Z. type EX with jumper.
- F. Seal-Offs: With filler fiber, compound, and removable cover.

2.4 METALLIC BOXES

- A. Flush and Concealed Outlet Boxes: Galvanized stamped steel with screw ears for device ring mounting, knock-out plugs, mounting holes, fixture studs if required, RACO or equivalent.
- B. Surface Outlet Boxes: Galvanized stamped steel same as above for use on ceilings; cast steel or aluminum with threaded hubs or bosses for use on walls.
- C. Large Boxes:
 1. Boxes exceeding 4-11/16-inches when required welded steel construction with screw cover and painted, steel gauge as required by physical size,
 2. Manufacturers:
 - a. Hoffman
 - b. Circle AW
 - c. Or equivalent.
- D. Systems:
 1. Boxes for systems devices as recommended by the systems manufacturer, suitable for the equipment installed.
 2. Equip with grounding lugs, brackets, device rings, etc., as required.

PART 3 EXECUTION

3.1 INSTALLATION

- A. Conceal conduits in finished spaces. Concealed conduits run in a direct line with long sweep bends and offsets. Where RMC and IMC embedded is in concrete below grade or in damp locations make watertight by painting the entire male thread with Rustoleum metal primer or equivalent before assembly.
- B. Route exposed conduit parallel or at right angles to structural building lines and neatly offset into boxes. Conduits attached directly to building surfaces closely follow the surfaces. Conduit fittings used to saddle under beams. Drilling or notching of existing beams, trusses on structural members coordinated with Architect prior to commencing.
- C. Rigidly secure RMC and IMC terminations at boxes, cabinets, and general wiring enclosures with double locknuts and bushings or approved fittings. Screw in conduit and engage at least five threads in hub where conduit boxes with threaded hubs or bosses are used. Use insulating bushings for conduits 1-1/4-inches or larger.
- D. Keep conduit and raceways closed with suitable plugs or caps during construction to prevent entrance of dirt, moisture, concrete, or foreign objects. Clean and dry raceways before installation of wire and at the time of acceptance.
- E. Pack spaces around conduits with polyethylene backing rods and seal with polyurethane caulking to prevent entrance of moisture where conduits are installed in sleeves or block-outs penetrating moisture barriers.
- F. Interior Conduit and Fittings: Minimum conduit size for power circuits shall be 3/4-inch for home-runs. Minimum conduit sized for control wiring shall be 1/2- inch.
- G. Exterior Conduit and Fittings: Rigid galvanized threaded UL labeled conduit shall be specified where subjected to physical damage.
- H. Threaded couplings shall be used with rigid conduit and IMC.
- I. IMC may be used in place of rigid galvanized where permitted by code.
- J. Steel Electric Metallic Tubing (EMT) UL labeled conduit may be used in interior partitions, above ceilings, and for surface application, except in corrosive and hazardous locations, where PVC coated rigid galvanized conduit is required to be used.
- K. Insulating bushings and insulated throat fittings shall be used throughout EMT installation.
- L. Compression fittings shall be used outdoors. Set screw type fittings may only be used indoors.
- M. Plastic jacketed rigid galvanized steel conduit shall be used in corrosive atmosphere.
- N. Flexible conduit used for motor make-up shall be liquid tight flexible conduit, minimum size 1/2 inch. Flexible conduit used for lighting fixture connections shall be steel, minimum size of 1/2-inch unless part of a manufactured luminaire assembly. Maximum length shall be 6'-0". Flexible conduit of any type shall not be used in interior partitions or in walls as a substitute for EMT, IMC or rigid steel conduit. A ground wire shall be pulled in all flexible conduits. All flexible conduits shall be supported per NEC. Distance between supports as allowed per NEC.
- O. Liquid tight flexible metal conduit shall be used on flexible conduit applications exposed to outdoor or moist locations.
- P. Liquid tight flexible metal conduit shall be used in raised floor computer room applications.
- Q. Rigid galvanized steel conduit shall be used outdoors, above grade, in damp locations.
- R. Conduit installed through a building wall shall have internal and external seals. Specify link seal or equivalent.
- S. Elbows used for medium voltage cable shall be long radius rigid steel.
- T. Grounding: Conduit crossing building expansion joints shall have expansion provision with grounding continuity.

3.2 CONDUIT

- A. RMC:
 - 1. Use in areas for wiring systems.
 - 2. Install where subject to mechanical injury.
 - 3. Install with threaded fittings made up tight.
- B. IMC:
 - 1. Use for circuits rated 600V and less where not in contact with earth or fill.
 - 2. Install with threaded fittings made up tight.
- C. EMT:
 - 1. Use in other dry protected locations for circuits rated 600V and less.
 - 2. Securely support and fasten whether exposed or concealed at intervals of nominally every 8-feet and within 24-inches of each outlet, ell, fitting, panel, etc.
- D. Flex:
 - 1. Use for connections to vibration producing equipment and where installation flexibility is required with a minimum 12-inches slack connection.
 - 2. Limit flex length to 36-inches for exposed equipment connections and 72-inches in concealed ceiling and wall cavities.
 - 3. Use PVC jacketed flex in wet locations, areas subject to washdown, and exterior locations.

3.3 RACEWAYS

- A. Surface metal wireways may be installed at locations to serve motor starters or other control devices where required by a multitude of wiring interconnections or physical layout.

3.4 FITTINGS

- A. Assemble continuous and secured metallic raceways and conduits to boxes, panels, etc., with appropriate fittings to maintain electrical continuity. Cut square and reamed smooth conduit joints with fittings drawn up tight.
- B. Do not use Crimp-on, tap-on, indenter type, malleable iron, or cast set screw fittings.

3.5 BOXES

- A. General:
 - 1. Outlet Boxes: Code required size to accommodate wires, fittings, and devices.
 - 2. Provide multi-gang boxes as required to accept devices installed with no more than one device per gang.
 - 3. Equip metallic boxes with grounding provisions.
- B. Size and Type:
 - 1. Flush wall switch and receptacle outlets used with conduit systems 4-inches square, 1-1/2-inches or deeper, with one or two-gang plaster ring, mounted vertically. Where three or more devices are at one location, use one piece multiple gang tile box or gang box with suitable device ring.
 - 2. Wall bracket and ceiling surface mounted luminaire outlets 4-inch octagon 1-1/2-inches deep with 3/8-inch fixture stud where required. Wall bracket outlets have single gang opening where required to accommodate luminaire canopy. Provide larger boxes or extension rings where quantity of wires installed requires more cubic capacity.
 - 3. Junction boxes installed in accessible ceiling or wall cavities or exposed in utility areas minimum of 4-inches square, 1-1/2 inches deep with appropriately marked blank cover.

4. Boxes for the special systems suitable for the equipment installed. Coordinate size and type with the system supplier.
- C. Pull Boxes:
1. Provide pull boxes where shown for installation of cable supports or where required to limit the number of bends in conduits to not more than three 90-degree bends.
 2. Use galvanized boxes of code-required size with removable covers installed so that covers will be accessible after work is completed.
- D. Installation:
1. Mount boxes and outlets at nominal centerline heights shown on the drawings.
 2. Adjust heights in concrete masonry unit (CMU) walls to prevent devices or finish plates from spanning masonry joints.
 3. Recessed Boxes:
 - a. Flush with finished surfaces or not more than 1/8-inch back, level and plumb.
 - b. Long screws with spacers or shims for mounting devices will not be acceptable.
 - c. No combustible material exposed to wiring at outlets.
 4. Covers for flush mounted boxes in finished spaces extend a minimum of 1/4-inch beyond the box edge to provide a finished appearance. Finish edge of cover to match cover face.
 5. Boxes installed attached to a stud in sheet rock walls equipped with opposite side box supports equivalent to Caddy 760. Install drywall screw prior to finish taping. Methods used to attach boxes to studs not to cause projections on the face of the stud to prevent full-length contact of sheet rock to the stud face.

3.6 PULL WIRES

- A. Install nylon pull lines in empty conduits larger than 1-inch where routing includes 25-feet or more in length or includes 180 degrees or more in bends.
- B. Where conduits requiring pull lines are stubbed out and capped, coil a minimum of 36-inches of pull line and tape at termination of conduit for easy future access. Label pull lines as to conduit starting or terminations point and intended future use.

END OF SECTION

SECTION 26 05 45

SEISMIC RESTRAINTS FOR ELECTRICAL RACEWAYS AND EQUIPMENT

PART 1 GENERAL

1.1 SUMMARY

- A. This Section includes:
 - 1. Seismic Bracing
 - 2. Channel Type Elements
 - 3. Bolting Accessories

1.2 RELATED SECTIONS

- A. Division 01, General Requirements
- B. Division 26, Electrical
- C. Section 26 05 29, Hangers and Supports for Electrical Systems

1.3 REFERENCED STANDARDS

- A. The following are the referenced standards:
 - 1. SMACNA Sheet Metal and Air Conditioning Contractor's National Association
 - 2. AISC American Institute of Steel Construction
 - 3. ASTM American Society for Testing and Materials
 - 4. AWS American Welding Society
 - 5. IBC International Building Code
 - 6. ICC International Code Council
 - 7. OSHPD Office of Statewide Health Planning and Development

1.4 QUALITY ASSURANCE

- A. General Requirements:
 - 1. Provide seismic restraints for equipment, both supported and suspended, conduits, and cable tray systems.
 - 2. Bracing of conduits and cable trays in accordance with the provisions set forth in the SMACNA seismic restraint manual.
 - 3. Review and approve structural requirements for restraints, including their attachment to the building structure by a registered structural engineer in the same state as the project.
 - 4. Attachments to supported or suspended equipment must be coordinated with the equipment manufacturer.
- B. Bracing of Conduits:
 - 1. Provide seismic bracing of conduit as detailed below:
 - 2. Exception: Conduits suspended by individual hangers 12-inches or less in length, as measured from the top of the conduit to the bottom of the support where the hanger is attached, need not be braced.
 - a. Brace electrical conduits 2-1/2 inch nominal diameter or larger.
 - b. Brace conduits located in electrical rooms, boiler rooms, mechanical equipment rooms, and refrigeration mechanical rooms that are 1-1/4-inch nominal diameter and larger.
- C. Suspended Equipment and Raceways:
 - 1. Cable Method: The seismic restraint shall consist of a combination of stranded steel aircraft cable with an added nut and neoprene and steel washer.

2. Cable attachment details, cable size, and the neoprene and steel washers shall be sized by the manufacturer and are to be indicated in the shop drawings.
 3. Provide detailed shop drawings for approval in sufficient time to allow structural attachment work to be incorporated into the normal work sequence.
- D. Seismic restraints, including anchors to building structure, designed by a registered professional structural engineer licensed in the state of Oregon. Design includes:
1. Number, size, capacity, and location of anchors for floor- or roof-mounted equipment. For curb-mounted equipment, provide design of attachment of both the unit to the curb and the curb to the structure. For units weighing greater than 2500 pounds, or curbs more than 10 feet long, provide substantiating calculations the curb can accept the prescribed seismic forces.
 2. Number, size, capacity, and location of seismic restraint devices and anchors for vibration-isolation and suspended equipment. Provide calculations, test data, or California OSHPD approval number verifying the horizontal and vertical ratings of the seismic restraint devices.
 3. Number, size, capacity, and location of braces and anchors for suspended raceways, bus ducts, and cable trays on as-built plan drawings.
 - a. Select a single seismic restraint system pre-designed to meet the requirements of the latest edition of the IBC such as the 1999 Mason Industries Seismic Restraint Guidelines for Suspended Piping, Ductwork, and Electrical Systems.
 - b. Details or designs from separate seismic restraint guidelines are not acceptable. Installation not addressed by the selected system shall be designed, detailed, and submitted alone with the as-built plan drawings.
 - c. Maximum seismic loads shall be indicated on drawings at each brace location. Drawings shall bear the stamp and signature of the registered professional structural engineer licensed in the state of Oregon who designed the layout of the braces.
- E. Supports, Hangers, and Anchors: Comply with the requirements of Section 26 05 29, Hangers and Supports for Electrical Systems, except anchor (expansion) bolts used for connection Level 3 have expansion anchor capacities equal to 50 percent of the ICC research report values.

1.5 SUBMITTALS

- A. Product Data: Submit product data for products specified herein.
- B. Shop Drawings:
1. Submit shop drawings complying with the requirements of the Quality Assurance article of this Section.
 2. Stamp shop drawings by a professional structural engineer licensed in the state of Oregon.
 3. Approve submittals prior to rack fabrication and installation.
- C. Calculations:
1. Submit seismic calculations indicating restraint loadings resulting from the design seismic forces presented in the Quality Assurance article of this Section.
 2. Include proper anchorage details and when applicable and include consideration of the types of concrete.
 3. Certify by a professional structural engineer licensed in the state of Oregon.
- D. Certifications:
1. Submit certification of seismic restraint's and building structural member's capability to safely accept loads resulting from seismic forces calculated in the previous paragraph.

2. Tests in three planes clearly showing ultimate strength and appropriate safety factors performed by independent laboratories and certified by a professional structural engineer licensed in the state of Oregon or calculations by a professional structural engineer licensed in the state of Oregon are acceptable.

PART 2 PRODUCTS

2.1 SEISMIC BRACING:

- A. Steel fabrication, in accordance with AISC M011 Manual, with structural steel shapes of ASTM A 36 steel.
- B. Welding in accordance with AWS D1.1.
- C. Design and sizes as required.
- D. Fastenings, bracing, and assembly selected by a professional structural engineer licensed in the state of Oregon.
- E. Show that the maximum stress in any structural steel member will not exceed 18,000 psi.

2.2 CHANNEL TYPE ELEMENTS

- A. 12 gauge formed steel, 1-5/8-inch square prime painted or chromate dip finish. Use spring-in nuts with grooves.

2.3 BOLTING ACCESSORIES

- A. Machine bolts with semi-finished nuts.

PART 3 EXECUTION

3.1 INSTALLATION

- A. Provide support assemblies to meet the seismic zone indicated. Equipment shall be braced and anchored to conform to the requirements listed under the Quality Assurance article of this Section.
- B. Seismically brace raceways, cable trays, and suspended bus duct to conform to the requirements listed under the Quality Assurance article of this Section.
- C. Provide pipeline seismic flexible connectors where piping crosses building earthquake joints. Arrange raceways and connectors for the amount of motion required. Maintain continuity of the grounding system for each of the joints.
- D. Do not use powder-actuated inserts.
- E. Seismic Restraints:
 1. Attach to structural members of the building, which are capable of withstanding the design load of the seismic restraint.
 2. Ensure load capacity of the structural members is greater than or equal to the capacity of the seismic restraint.

END OF SECTION

SECTION 26 05 53
IDENTIFICATION FOR ELECTRICAL SYSTEMS

PART 1 GENERAL

1.1 SUMMARY

- A. This Section includes:
 - 1. Labels

1.2 RELATED SECTIONS

- A. Division 01, General Requirements
- B. Division 26, Electrical
- C. Section 26 05 19, Low Voltage Electrical Power Conductors and Cables
- D. Section 26 05 33, Raceways and Boxes for Electrical Systems

PART 2 PRODUCTS

2.1 LABELS

- A. Pre-printed:
 - 1. Permanent material pre-printed with black on white, with adhesive backing.
 - 2. Manufacturer:
 - a. Brady
 - b. 3M
 - c. Or equal.
- B. Engraved Laminated Plastic:
 - 1. 3-ply laminated plastic, colors indicated herein, with beveled edges, engraved letters, and stainless steel screw attachment.
 - 2. Nameplate length to suit engraving.
 - 3. Adhesive attachment is not acceptable.
- C. Clear Plastic Tape:
 - 1. Black (normal) or red (emergency or standby) 12 point Helvetica medium text, clear adhesive backing, field printed with proper equipment for device labeling.
 - 2. Manufacturers:
 - a. Brother P-Touch
 - b. Dyno-tape
 - c. Kroy
 - d. Or equal.
- D. Wire Markers:
 - 1. White with black numbers, adhesive-backed tape on dispenser roll.
 - 2. Manufacturers:
 - a. Brady
 - b. 3M
 - c. Or equal.
- E. Feeder Conduit Marking:
 - 1. Provide one-piece snap-around vinyl feeder conduit markers for feeder conduits.
 - 2. Provide custom label, black letters on orange background indicating destination equipment, 1-1/4-inch high letters (minimum) – Seton Setmark Pipe Marker Series.

3. Provide additional one-piece snap-around vinyl label, black letters on orange background for voltage designation (i.e., 277/480V, 120/208V).
 4. Secure labels to conduits using plastic tie wrap, two per label.
- F. Marker Pen: Black permanent marker suitable for writing on metallic surfaces.

PART 3 EXECUTION

3.1 EQUIPMENT

- A. Provide engraved laminated plastic nameplate on the face of disconnect switches, motor starters, relays, contactors, and etc., indicating equipment served (e.g., AHU-1) and equipment load (e.g., 20 hp). Provide additional engraved laminated plastic nameplate indicating serving panel designation and circuit number.
- B. Provide clear plastic tape label for relays, contactors, time switches, and miscellaneous equipment provided under this Division of work indicating equipment served.

3.2 FEEDER CONDUIT

- A. Provide feeder conduit marker for electrical feeders.
- B. Provide markers when exiting source equipment and located along the entire conduit length 20-feet on centers in exposed areas, above ceilings, and upon entering or leaving an area or room.

3.3 RACEWAYS AND BOXES

- A. Label pull boxes and junction boxes for systems with paint or marker pen on box cover identifying system. Where box covers are exposed in finished areas, label inside of cover.
- B. Color label covers as follows:
 1. 480Y/277V wiring Orange
 2. 208Y/120V wiring Black
 3. Fire Alarm Red
 4. Communications Green
 5. Security Blue
- C. Label each end of pull wires left in empty conduits with tags or tape indicating location of other end of wire.

3.4 EXISTING EQUIPMENT

- A. Provide new nameplates and labels for existing distribution equipment in accordance with panel descriptions shown on the Drawings. Provide new labels for feeder devices where labels are non-existent, incorrect, or confusing on existing distribution panels affected by this work.
- B. Equip existing branch circuit panelboards scheduled to remain with new, accurate, typed, circuit directories where circuiting changes are made.

END OF SECTION

SECTION 26 05 73
OVERCURRENT PROTECTIVE DEVICE COORDINATION STUDY

PART 1 GENERAL

1.1 SUMMARY

- A. This Section includes:
 - 1. Studies and Analysis

1.2 RELATED SECTIONS

- A. Division 01, General Requirements
- B. Division 26, Electrical
- C. Section 26 05 19, Low Voltage Electrical Power Conductors and Cables

1.3 REFERENCES

- A. IEEE 141 Recommended practice for electrical power distribution and coordination of industrial and commercial power systems
- B. IEEE 242 Recommended practice for protection and coordination of industrial and commercial power systems
- C. IEEE 399 Recommended practice for industrial and commercial power system analysis
- D. IEEE 1584 Guide for performing arc-flash hazard calculations
- E. NFPA 70 National Electrical Code, latest addition
- F. NFPA 70E Standard for Electrical Safety in the Workplace, latest addition

1.4 SUBMITTALS

- A. Overcurrent Device Coordination Study
- B. Device Setting Recommendations
- C. Arc Flash Hazard Analysis and report
- D. Arc Flash Equipment Labeling Recommendations
- E. Arc Flash Label Example

PART 2 PRODUCTS

2.1 ACCEPTABLE MANUFACTURERS

- A. Emerson
- B. Electrical Systems Analysis
- C. Qualified engineers of the switchgear manufacturer.

2.2 STUDIES AND ANALYSIS

- A. Overcurrent Device Coordination Study:
 - 1. Provide a coordination study for the electrical overcurrent devices to assure proper equipment and personnel protection.
 - a. The starting point of each study will be one overcurrent protective device “upstream” of the starting point of the scope of work of the project and terminating at the farthest point “downstream” affected by the “upstream” changes.
 - 2. Present an organized time-current analysis of each protective device in series from the individual device back to the source. Reflect the operation of each device during normal and abnormal current conditions.
 - 3. Complete and submit prior to procurement of electrical distribution equipment including: switchgear, switchboards, panelboards, disconnects and overcurrent protection devices.

4. Demonstrate selective coordination of the emergency system in conformance with National Electrical Code Section 700. Standby and optional standby systems on the load side of automatic transfer switches are required to coordinate with overcurrent protection devices on the line side of automatic transfer switches.
 5. Bring to the attention of the Engineer devices that fail to selectively coordinate as required to meet code.
 6. Provide alternative options and/or scenarios for devices that fail to coordinate and demonstrate methods/devices needed to selectively coordinate for the engineers review and acceptance.
 7. Provide pertinent information required by the preparers to complete the study.
 8. Include a system one-line diagram and protective coordination curves.
 - a. Determine the required settings of protective devices to assure selective coordination.
 - b. Graphically illustrate on log paper that adequate time separation exists between series devices.
 - c. Plot the specific time-current characteristics of each protective device so that upstream devices are clearly depicted on one sheet.
 - d. Time Current Curves: Develop for both phase and ground protective devices.
 - e. Provide the following specific information shown on the coordination curves:
 - 1) Device identification.
 - 2) Voltage and current ratio for curves.
 - 3) 3-phase and 1-phase ANSI damage points for each transformer.
 - 4) No-damage, melting, and clearing curves for fuses.
 - 5) Cable damage curve.
 - 6) Transformer inrush points.
 - 7) Maximum short circuit cut-off point.
 - 8) Motor starting locked rotor curves.
 - 9) Clearly marked short circuit current levels through each protective device and branch.
 - f. Develop a table that summarizes the settings selected for the protective devices. Included the following:
 - 1) Device identification.
 - 2) Circuit breaker sensor rating, long-time, short-time, instantaneous settings, and time bands.
 - 3) Fuse rating and type.
 - 4) Ground fault pickup and time delay.
 - 5) Provide characteristic time-current curves for each adjustable overcurrent protective device showing pickup settings, time delay bands, and device operating times. Include trip adjustment time dials and available settings corresponding to each characteristic time-current curve.
- B. Arc Flash Hazard Analysis:
1. Provide an Arc Flash Hazard Study per the requirements set forth in NFPA 70E. The arc flash hazard analysis performed according to the IEEE 1584 equations that are presented in NFPA70E.

2. Use study to determine:
 - a. Arc flash incident energies.
 - b. Arc flash boundaries.
 - c. Shock hazard boundaries.
 - d. Personal protective equipment (PPE) for energized electrical equipment.
3. Provide the following information for each system mode of operation and documented. The study includes:
 - a. Equipment name and voltage.
 - b. Equipment device name and ANSI function
 - c. Equipment type
 - d. Equipment arc gap
 - e. Bolted and estimated arcing fault current at the fault point (equipment) in symmetrical amperes. The estimated arcing current should be based on the arcing current equations used.
 - f. Trip time, opening time, and total clearing time (total Arc time) of the protective device.
 - g. Worst-case arc flash boundary for each bus/equipment in the model.
 - h. Worst-case arc flash hazard incident energy in cal/cm² for each bus/equipment in the model.
 - i. Worst-case personal protective equipment (PPE) for each bus/equipment in the model.
 - j. Indicate Danger/Hazardous areas where incident energy is greater than 40 cal/cm² and provide recommendations to reduced arc flash energy levels for these areas.
 - k. Flag results where 85 percent arcing current provided worst-case results.
4. Arc flash study report format:
 - a. Introduction
 - b. Methodology
 - c. Backup Information
 - d. Key Assumptions
 - e. IEEE 1584-2002 Considerations
 - f. Arc flash reduction options: Overcurrent protective device changes.
 - g. Explanation of data in arc flash hazard report tables.
 - h. NFPA 70E Information.
 - 1) Shock hazards with covers removed.
 - 2) Shock hazard approach boundaries:
 - a) Limited Approach Boundary
 - b) Restricted Approach Boundary
 - c) Prohibited Approach Boundary
 - 3) Arc Flash Hazard Boundaries
 - i. Results of arc flash hazard analysis for high voltage, medium voltage, and low voltage systems, including:
 - 1) Working Distances
 - 2) Energy Levels

- 3) PPE Requirements
- 4) Recommendations to reduce arc flash hazard energy and exposure.
- j. Arc Flash Hazard Report
- k. Electronic File
5. Provide labels for the project.

PART 3 EXECUTION

3.1 SETTINGS AND ADJUSTMENT

- A. Set and adjust breakers in the distribution system per the recommendations of the coordination study and settings table.
- B. Provide protective covers and locking devices on breakers to secure settings from accidental changes.

3.2 ARC FLASH WARNING LABELS

- A. Provide a 3-1/2-inch by 5-inch thermal transfer type label of high adhesion polyester for each work location analyzed.
- B. Labels will be based on recommended overcurrent device settings and will be provided after the results of the analysis have been presented to the Owner and after any system changes, upgrades, or modifications have been incorporated in the system.
- C. The label includes the following information, at a minimum:
 1. Location Designation
 2. Nominal Voltage
 3. Flash Protection Boundary
 4. Hazard Risk Category
 5. Incident Energy
 6. Working Distance
 7. Engineering Report Number, Revision Number, and Issue Date
- D. Machine printed labels with no field markings.
- E. One arc flash label provided for each, unit substation primary and secondary side, switchboard, switchgear section, motor control center, panelboard, and busway.

3.3 ARC FLASH TRAINING

- A. Train the Owner's qualified electrical personnel of the potential arc flash hazards associated with working on energized equipment (minimum of 4 hours). Training certified for continuing education units (CEUs) by the International Association for Continuing Education Training (IACET) of equivalent.

END OF SECTION

SECTION 26 05 80
ELECTRICAL TESTING

PART 1 GENERAL

1.1 SUMMARY

- A. This Section includes:
 - 1. Testing Equipment

1.2 RELATED SECTIONS

- A. Division 01, General Requirements
- B. Division 26, Electrical
- C. Section 26 05 19, Low Voltage Electrical Power Conductors and Cables
- D. Section 26 05 26, Grounding and Bonding for Electrical Systems

1.3 TESTING CRITERIA

- A. General:
 - 1. Perform field tests and operational checks to assure that all electrical equipment, both contractor and Owner supplied, is operational within industry and manufacturer's tolerances, and is installed in accordance with design specifications.
 - 2. The tests and operational check shall determine the suitability for energization.
 - 3. Schedule tests and give a minimum of one week's advance notice of time and date to the Architect and Owner for any major systems tests specified in this Section.
 - 4. The testing company shall provide the equipment and technical personnel to perform all tests and inspections. At Contractors expense, furnish any personnel necessary to assist in the testing and inspection.
 - 5. When tests and inspections are complete, attach a label to the devices tested. Provide on the label, the name of the testing company, date of tests, and initials of the Engineer who performed the tests.
- B. Responsibilities:
 - 1. Clean the equipment, torque down accessible bolts according to the equipment manufacturer's instructions; perform routine insulation resistance tests on branch and feeder circuits, continuity checks on branch and control wiring, and rotation tests for distribution and utilization equipment.
 - 2. Furnish a complete set of current plans and specifications to the testing company prior to commencement of testing. At each test site, provide test control power necessary to perform the tests specified. Consult the test organization as to the specific power requirements. Notify the testing organization when the equipment and systems are ready for their inspections and testing. After review by the testing engineer, correct deficiencies noted by the testing company.
 - 3. Responsible for having the manufacturer of each equipment and/or system provide factory trained representatives(s) that will perform required functional testing, checkout, and repairs in order to pronounce the equipment and/or systems meet the requirements of these specifications and Drawings and it is ready for startup testing and commissioning by the testing organization as specified hereafter.
 - 4. Furnish settings of protective devices by the Engineer, in conjunction with Utility.
 - 5. Testing organization to notify Engineer prior to the commencement of testing. The testing organization, set, and adjust the protective devices and associated auxiliary timing devices in accordance with the values furnished by the Engineer. The testing organization maintains a written record of tests and, upon completion of the test, include them in a final report. Detail deficiencies in the system material, workmanship, or design.

C. Implementation:

1. Safety practices comply with applicable state and local safety orders, as well as with the Occupational Safety and Health Act (OSHA). Compliance with the National Fire Protection Association (NFPA) standard NFPA 70E, and the Accident Prevention Manual for Industrial Operations of the National Safety Council.
2. Tests, other than phase rotation and operational tests, only performed on apparatus that is deenergized. The testing company's lead test engineer for the project designated safety representative and supervise testing observations and safety requirements. Do not proceed with Work until determined that it is safe to do so.
3. Power Circuits: Conductors shorted to ground by a hotline grounding device approved for the purpose. Provide warning signs and protective barriers as necessary to conduct the tests safely.

D. Reports:

1. General: Provide full documentation of tests in the form of a report.
2. Test report includes the following sections:
 - a. Scope of Testing
 - b. Equipment Tested
 - c. Description of Test
 - d. Test Results
 - e. Conclusions and Recommendations
 - f. Appendix, including Test Forms
3. Record each piece of equipment on a data sheet listing the condition of the equipment as found and as left. Include recommendations for necessary repair and/or replacement parts. Indicate on data sheets the name of the engineer who tested the equipment and the date of the test completion.
4. Submit record copies of the completed test report no more than 30 days after completion of the testing and inspection.

1.4 REFERENCES

- A. The testing and inspection comply with applicable sections of the applicable codes and standards listed in Section 26 05 00, Common Work Results of Electrical of the project specifications.
- B. The inspection and testing comply with the project plans and specifications, as well as with the manufacturer's drawings, instruction manuals, and other applicable data that may be provided by the Engineer, for the apparatus tested.

1.5 QUALIFICATIONS

A. Testing Organization:

1. Independent division of the manufacturer of the assembled products being tested. If an outside testing organization is utilized, a representative of the manufacturer under contract by the testing company. Be present during testing to ensure the testing is performed properly and deficiencies discovered are promptly corrected.
2. Full Service Company that employs factory trained test engineers capable of troubleshooting, as well as identifying power equipment problems.
3. Perform Work outlined under the full time, onsite supervision of a graduate engineer with a minimum of 5 years of field testing experience.
4. Upon request, submit proof of its qualifications.

PART 2 PRODUCTS

2.1 TESTING EQUIPMENT

- A. Testing agency to have calibration program, which maintains applicable test instrumentation within rated accuracy. Traceable accuracy to the National Bureau of Standards in an unbroken chain. Calibrate instruments calibrated in accordance with the following frequency schedule:
 - 1. Field Instruments: 6 months maximum.
 - 2. Laboratory Instruments: 12 months.
 - 3. Leased Specialty Equipment: 12 months (where accuracy is guaranteed by lessor). Dated calibration labels visible on test equipment.

PART 3 EXECUTION

3.1 EQUIPMENT TO BE TESTED

- A. Section 26 05 19, Low Voltage Electrical Power Conductors and Cables:
 - 1. For circuits rated 400A or higher perform tests listed in the NETA 2017 Acceptance Testing Specifications for Low-Voltage Cables, Section 7.3.2.
- B. Section 26 05 26, Grounding and Bonding for Electrical Systems:
 - 1. Perform tests listed in the NETA 2017 Acceptance Testing Specifications for Grounding Systems, Section 7.13.

END OF SECTION

EXHIBIT 1



SUBMITTAL

Project

PAE - OSU Dixon Rec Ctr

Date

Monday, August 06, 2018

General Contractor

Mechanical Contractor

Mechanical Engineer

TZ Hristov
Airefco Inc

Table Of Contents

Project: PAE - OSU Dixon Rec Ctr
Prepared By: TZ Hristov

11/15/2018
12:22AM

225 Air Cooled Screw	3
Unit Report.....	4
Certified Drawing.....	5
Field Wiring Diagram.....	8
Detailed Performance Report.....	11

225 Air Cooled Screw

Project: PAE - OSU Dixon Rec Ctr
Prepared By: TZ Hristov

11/15/2018
12:22AM

225 Air Cooled Screw

**Tag Cover Sheet
Unit Report
Certified Drawing
Wiring Diagram
Detailed Performance Report**

Unit Report For 225 Air Cooled Screw

Project: PAE - OSU Dixon Rec Ctr
 Prepared By: TZ Hristov

11/15/2018
 12:22AM

Unit Information

Tag Name:..... **225 Air Cooled Screw**
 Model Number:..... **30XV225**
 Condenser Type:..... **Air Cooled**
 Compressor Type:..... **VFD Screw**
 Nameplate Voltage:..... **460-3-60** V-Ph-Hz
 Quantity:..... **1**
 Manufacturing Source:..... **Charlotte, NC USA**
 Refrigerant:..... **R134A**
 Independent Refrigerant Circuits:..... **2**
 Capacity Control Steps:..... **0**
 Minimum Capacity:..... **15.0** %
 Shipping Weight:..... **12902** lb
 Operating Weight:..... **13185** lb
 Unit Length:..... **252** in
 Unit Width:..... **88** in
 Unit Height:..... **99** in

Accessories and Installed Options

Control Transformer
 Non-Fused Disconnect
 Flooded Evaporator, 2 pass, with heater
 Variable Speed Condenser Fans
 BACnet / Modbus Translator
 Coil Trim Panels
 Low Ambient Head Pressure Control
 Standard Tier

Chiller Warranty Information (Note: for US & Canada only)

First Year - Parts Only (Standard)
 Start up, First Unit
 Complete Unit Year 1-1.5 Parts & Labor

Ordering Information

Part Number	Description	Quantity
30XV-2256S400-410	Packaged Chiller	1
	Base Unit	
	Control Transformer	
	Non-Fused Disconnect	
	Flooded Evaporator, 2 pass, with heater	
	Variable Speed Condenser Fans	
	BACnet / Modbus Translator	
	Coil Trim Panels	

Certified Drawing for 225 Air Cooled Screw

Project: PAE - OSU Dixon Rec Ctr
Prepared By: TZ Hristov

11/15/2018
12:22AM

NOTES:

- UNIT MUST HAVE CLEARANCES AS FOLLOWS:
TOP - DO NOT RESTRICT.
SIDES AND END - 6" FROM SOLID SURFACE.
FOR AIRFLOW SIDE - 8" REQUIRED FOR COIL SERVICE AREA.
IF MULTIPLE UNITS ARE INSTALLED AT THE SAME SITE, A MINIMUM SEPERATION OF 10FT (3M) BETWEEN THE SIDES OF THE MACHINES IS REQUIRED TO MAINTAIN PROPER AIRFLOW.
- FACTORY WIRING IS IN ACCORDANCE WITH UL 1995 STANDARDS. FIELD MODIFICATIONS OR ADDITIONS MUST BE IN COMPLIANCE WITH ALL APPLICABLE CODES.
- WIRING FOR MAIN FIELD SUPPLY MUST BE RATED 75C MINIMUM. USE COPPER FOR ALL UNITS.

POWER ENTRY OPTION	UNIT SIZE	DISCONNECT OPTION	# COND. PER PHASE	LUG RANGE
SINGLE POINT POWER (200 - 575V)	ALL	NO	4	#4 AWG - 500 KCMIL
DUAL POINT POWER (200 - 575V)	ALL	NO	2	#4 AWG - 500 KCMIL
SINGLE POINT POWER (380 - 575V)	225-325	NFD	4	4/0 - 500 KCMIL
DUAL POINT POWER (380 - 575V)	225-325	NFD	2	2/0 - 500 KCMIL

- TEMPERATURE RELIEF DEVICES ARE LOCATED ON LIQUID LINES, AND ECONOMIZER ASSEMBLIES AND HAVE 1/4" AND 3/8" FLARE CONNECTION.
- PRESSURE RELIEF DEVICES ARE LOCATED ON THE EVAPORATOR (3/4" NPT MALE CONNECTOR) AND ON EACH OIL SEPARATOR (3/8" FLARE CONNECTOR).
- DIMENSIONS SHOWN ARE IN INCHES, DIMENSIONS IN [] ARE IN MM.

UNIT	CENTER OF GRAVITY									
	MCHX		CGx AL/CU		CU/CLU		CGz			
	INCH	MM	INCH	MM	INCH	MM	INCH	MM		
30XV-225 STD	124.7	3166	124.3	3157	123.6	3140	46.7	1187	33.0	838

⊕ SYMBOL DENOTES CG



THIS DOCUMENT IS THE PROPERTY OF UTC CLIMATE CONTROLS AND IS DELIVERED UPON THE EXPRESS CONDITION THAT THE CONTENTS WILL NOT BE DISCLOSED OR USED WITHOUT WRITTEN CONSENT.

SUBMISSION OF THESE DRAWINGS OR DOCUMENTS DOES NOT CONSTITUTE PART PERFORMANCE OR ACCEPTANCE OF CONTRACT.

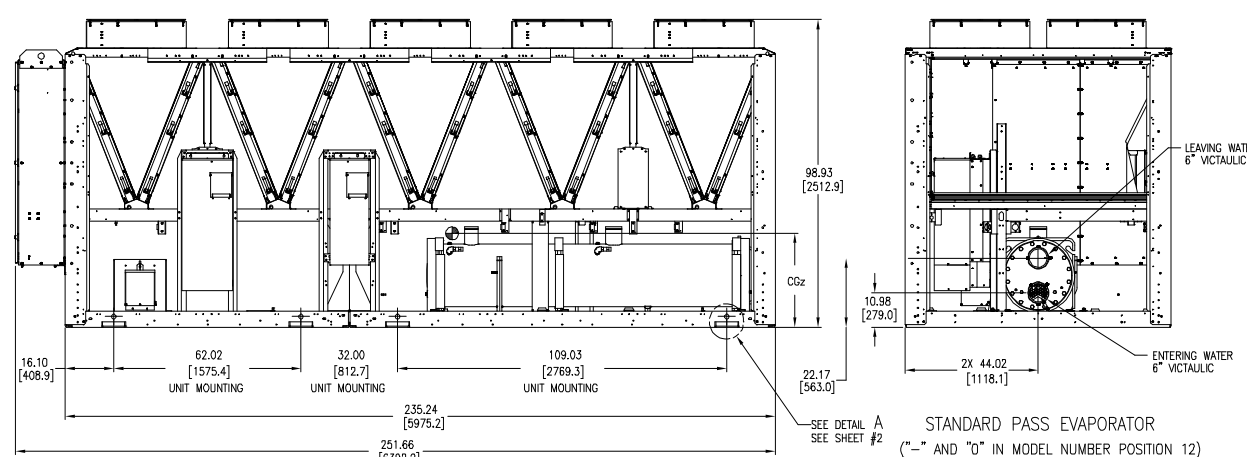
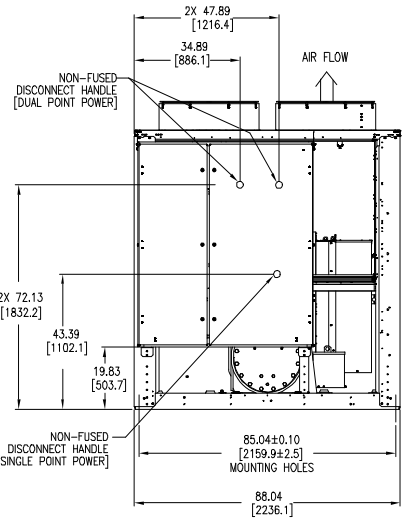
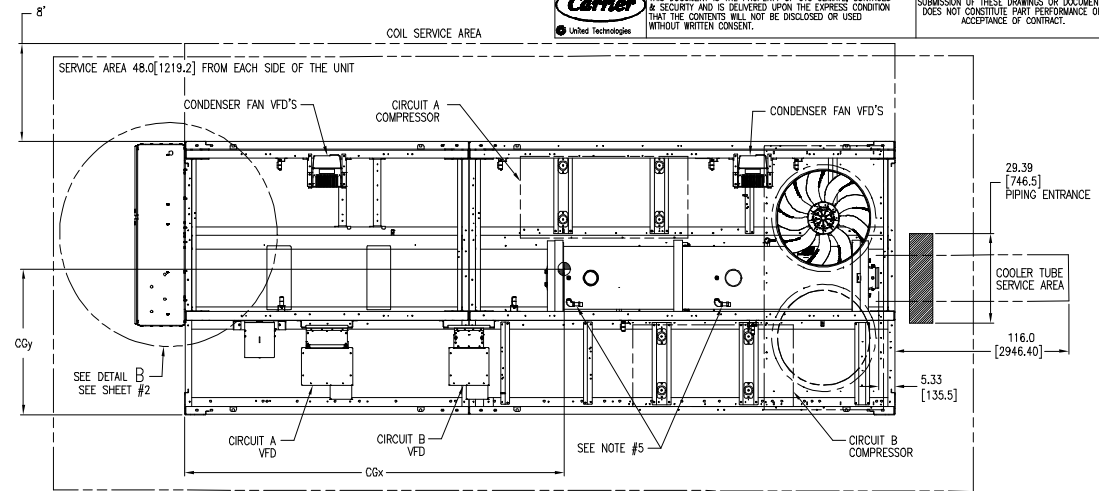

ITC CLASSIFICATION	SHEET	DATE	SUPERCEDES	MODEL NUMBER	REV
U.S. ECCN:EAR99	1 OF 3	04/17/17	-	30XV 225 STD TIER AIR COOLED CHILLER	B

Certified Drawing for 225 Air Cooled Screw

Project: PAE - OSU Dixon Rec Ctr
 Prepared By: TZ Hristov

11/15/2018
 12:22AM



THIS DOCUMENT IS THE PROPERTY OF UTC CLIMATE, CONTROLS & SECURITY AND IS DELIVERED UPON THE EXPRESS CONDITION THAT THE CONTENTS WILL NOT BE DISCLOSED OR USED WITHOUT WRITTEN CONSENT.

SUBMISSION OF THESE DRAWINGS OR DOCUMENTS DOES NOT CONSTITUTE PART PERFORMANCE OR ACCEPTANCE OF CONTRACT.

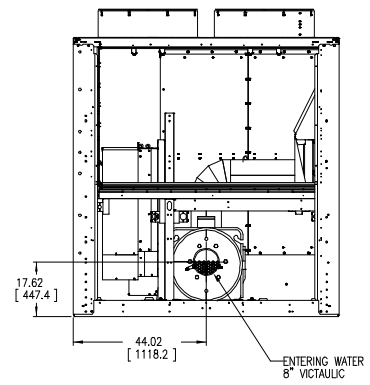

MINUS 1 PASS EVAPORATOR
 ("1" IN MODEL NUMBER POSITION 12)

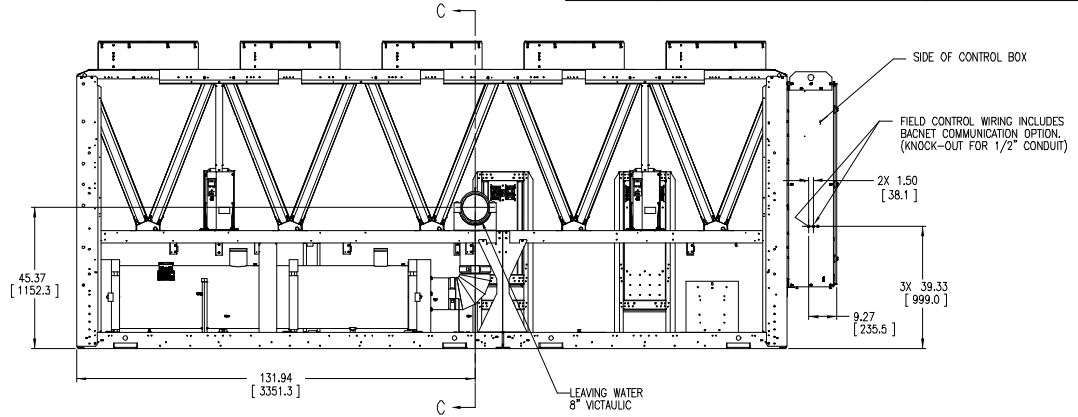

PREFERRED MAIN POWER SUPPLY CONDUIT ROUTING.
 GENERIC LOCATION - DO NOT PLACE CONDUIT IN FRONT OF CONTROL PANEL.
 ACCESS FOR SERVICE IS REQUIRED.

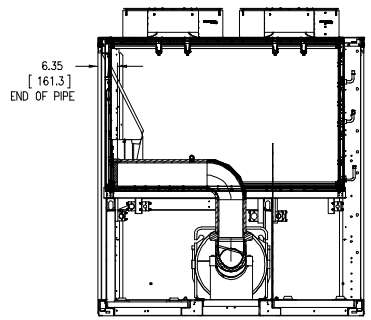

SECTION C-C

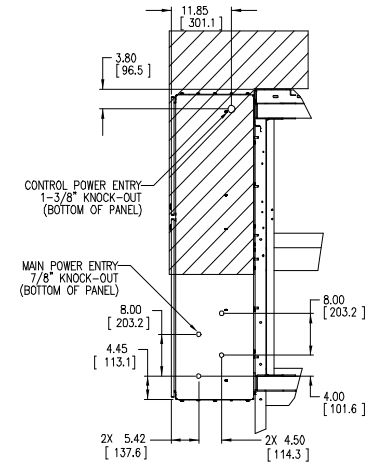

DETAIL B
 FROM SHEET #1
 (TOP VIEW - KNOCK OUTS ON BOTTOM OF CONTROL BOX)

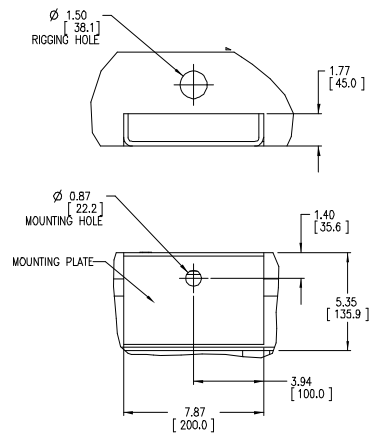

DETAIL A
 AT (8) PLCS.
 FROM SHEET #1

ITC CLASSIFICATION U.S. ECCN: EAR99	SHEET 2 OF 3	DATE 04/17/17	SUPERCEDES -	30XV 225 STD TIER AIR COOLED CHILLER	30XV60001300	REV B
--	-----------------	------------------	-----------------	--------------------------------------	--------------	----------

Certified Drawing for 225 Air Cooled Screw

Project: PAE - OSU Dixon Rec Ctr
 Prepared By: TZ Hristov

11/15/2018
 12:22AM



THIS DOCUMENT IS THE PROPERTY OF UTC CLIMATE, CONTROLS & SECURITY AND IS DELIVERED UPON THE EXPRESS CONDITION THAT THE CONTENTS WILL NOT BE DISCLOSED OR USED WITHOUT WRITTEN CONSENT.

SUBMISSION OF THESE DRAWINGS OR DOCUMENTS DOES NOT CONSTITUTE PART PERFORMANCE OR ACCEPTANCE OF CONTRACT.

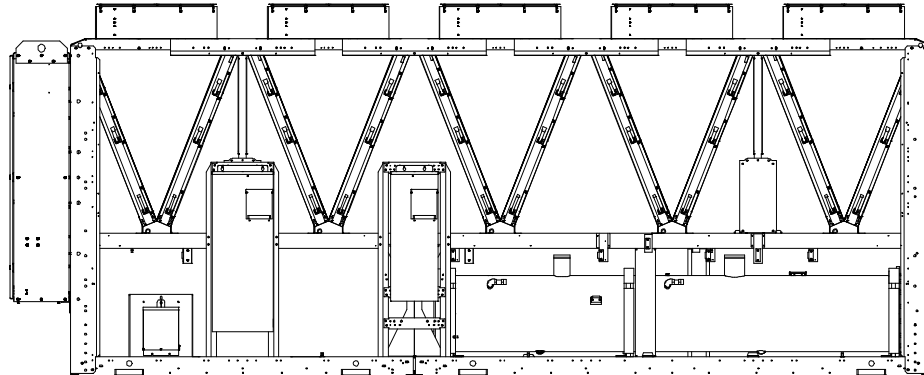
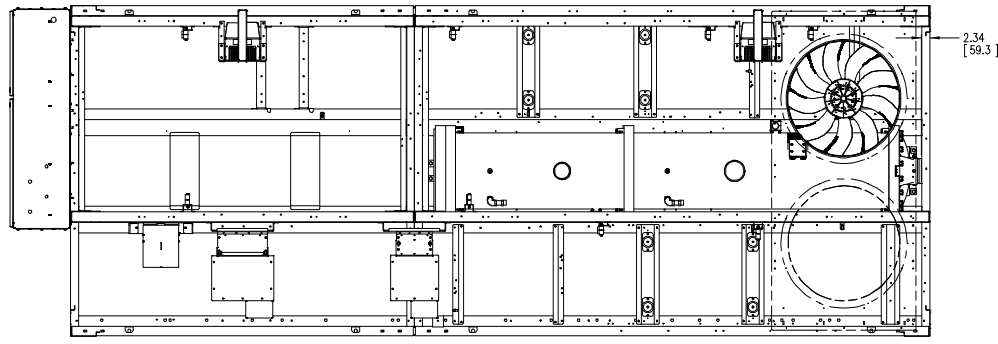

BRINE COOLER OPTION

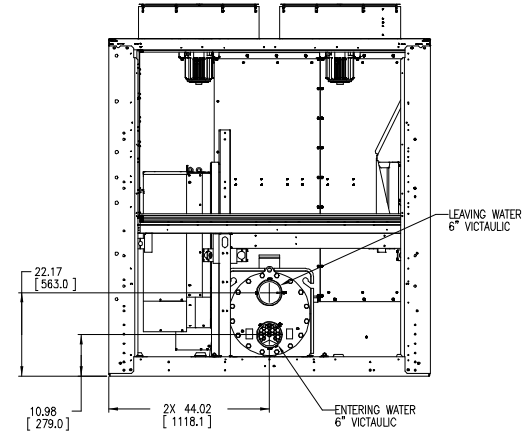

BRINE EVAPORATOR
 ("2" IN MODEL NUMBER POSITION 12)

ITC CLASSIFICATION U.S. ECCN: EAR99	SHEET 3 OF 3	DATE 04/17/17	SUPERCEDES -	30XV 225 STD TIER AIR COOLED CHILLER	30XV60001300	REV B
--	-----------------	------------------	-----------------	--------------------------------------	--------------	----------

Field Wiring Diagram for 225 Air Cooled Screw

Project: PAE - OSU Dixon Rec Ctr
Prepared By: TZ Hristov

11/15/2018
12:22AM

NOTES:

1. FACTORY WIRING IS IN ACCORDANCE WITH UL 1995 STANDARDS. FIELD MODIFICATIONS OR ADDITIONS MUST BE IN COMPLIANCE WITH ALL APPLICABLE CODES.
2. WIRING FOR MAIN FIELD SUPPLY MUST BE RATED 75C MINIMUM. USE COPPER FOR ALL UNITS.

POWER ENTRY OPTION	UNIT SIZE	DISCONNECT OPTION	# OF CONDUCTORS PER PHASE	LUG RANGE
SINGLE POINT POWER (230V)	140-200	NO	4	#2AWG-750 KCMIL
SINGLE POINT POWER (380-575V)	ALL	NO	2	#2AWG-600 KCMIL
DUAL POINT POWER (200V)	140-200	NO	3	3/0-400 KCMIL
DUAL POINT POWER (380-575V)	140-200	NO	1 OR (2)	2/0-500 KCMIL OR (2/0-250 KCMIL)
DUAL POINT POWER (380-575V)	225-325	NO	2	2/0-500 KCMIL
SINGLE POINT POWER (380-575V)	140-200	NFD	2	2/0-500 KCMIL
SINGLE POINT POWER (380V)	225-325	NFD	4	4/0-500 KCMIL
SINGLE POINT POWER (460-575V)	225-325	NFD	3	3/0-400 KCMIL
DUAL POINT POWER (380-575V)	140-200	NFD	1 OR (2)	2/0-500 KCMIL OR (2/0-250 KCMIL)
DUAL POINT POWER (380-575V)	225-325	NFD	2	2/0-500 KCMIL
SINGLE POINT POWER (380V)	350-500	NO	6	#2AWG-750 KCMIL
SINGLE POINT POWER (460-575V)	350-500	NO	4	#2AWG-750 KCMIL
DUAL POINT POWER (380V)	350-500	NO	4	#2AWG-750 KCMIL
DUAL POINT POWER (460-575V)	350-500	NO	2	#2AWG-600 KCMIL
DUAL POINT POWER (460-575V) (HSCCR)	350-500	NO	3	3/0-400 KCMIL
SINGLE POINT POWER (380V)	350-500	NFD	6	#2AWG-600 KCMIL
SINGLE POINT POWER (460-575V)	350-500	NFD	4	4/0-500 KCMIL

3. TERMINALS 9 AND 10 OF TBS ARE FOR FIELD EXTERNAL CONNECTIONS FOR REMOTE ON-OFF. THE CONTACTS MUST BE RATED FOR DRY CIRCUIT APPLICATION CAPABLE OF HANDLING A 24VAC LOAD UP TO 50 MA.
4. TERMINALS 11 AND 23 OF TB6 ARE FOR CONTROL OF CHILLED WATER PUMP 1 (PMP 1) STARTER. TERMINALS 15 AND 22 OF TB6 ARE FOR CONTROL OF CHILLED WATER PUMP 2 (PMP 2) STARTER. THE MAXIMUM LOAD ALLOWED FOR THE CHILLED WATER PUMP RELAY IS 5 VA SEALED, 10 VA INRUSH AT 24 V. FIELD POWER SUPPLY IS NOT REQUIRED.
5. TERMINALS 12 AND 21 OF TB6 ARE FOR AN ALARM RELAY. THE MAXIMUM LOAD ALLOWED FOR THE ALARM RELAY IS 10 VA SEALED, 25 VA INRUSH AT 24V. FIELD POWER SUPPLY IS NOT REQUIRED.
6. MAKE APPROPRIATE CONNECTIONS TO TB6 AS SHOWN FOR ENERGY MANAGEMENT BOARD OPTIONS. THE CONTACTS FOR OCCUPANCY OVERRIDE, DEMAND LIMIT AND ICE DONE OPTIONS MUST BE RATED FOR DRY CIRCUIT APPLICATION CAPABLE OF HANDLING A 24VAC LOAD UP TO 50 MA.
7. TERMINAL BLOCKS, TBS & TB6 ARE LOCATED IN THE LOW VOLTAGE SECTION OF POWERBOX FOR ALL UNITS. REFER TO CERTIFIED DIMENSIONAL DRAWING FOR EACH UNIT TO GET THE EXACT LOCATIONS.
8. REFER TO CERTIFIED DIMENSIONAL DRAWINGS FOR EXACT LOCATIONS OF THE MAIN POWER AND CONTROL POWER ENTRANCE LOCATIONS.
9. TERMINALS 18 & 26 OF TB6 ARE FOR ALERT RELAY AND TERMINALS 20 & 26 OF TB6 ARE FOR SHUTDOWN RELAY. THE MAXIMUM LOAD ALLOWED FOR THE ALERT AND SHUTDOWN RELAY IS 10 VA SEALED, 25 VA INRUSH AT 24V. FIELD POWER SUPPLY IS NOT REQUIRED.

LEGEND:

- A - ALARM
- PMP - CHILLED WATER PUMP
- EMM - ENERGY MANAGEMENT
- TB - TERMINAL BLOCK
- MLV - MINIMUM LOAD VALVE
- NEC - NATIONAL ELECTRIC CODE
- HSCCR - HIGH SHORT CIRCUIT CURRENT RATING
- SCCR - SHORT CIRCUIT CURRENT RATING



THIS DOCUMENT IS THE PROPERTY OF UTC CLIMATE, CONTROLS & SECURITY AND IS DELIVERED UPON THE EXPRESS CONDITION THAT THE CONTENTS WILL NOT BE DISCLOSED OR USED WITHOUT WRITTEN CONSENT.

SUBMISSION OF THESE DRAWINGS OR DOCUMENTS DOES NOT CONSTITUTE PART PERFORMANCE OR ACCEPTANCE OF CONTRACT.

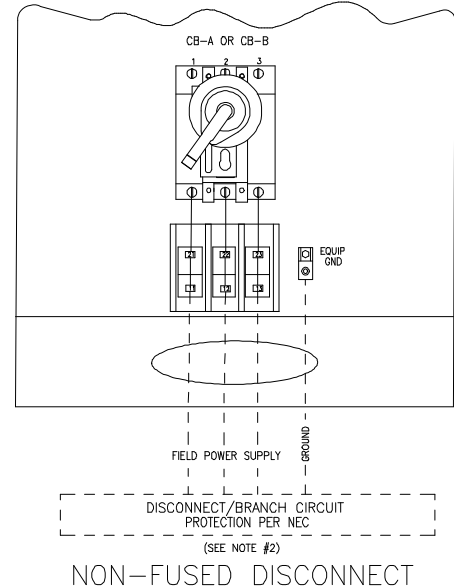
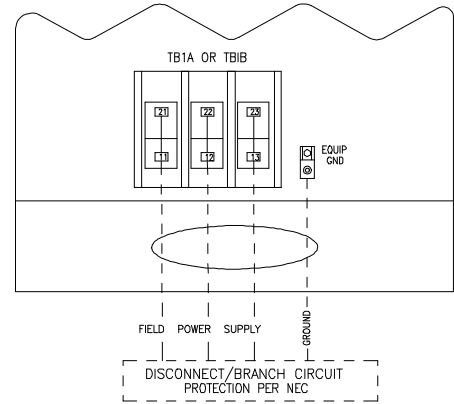
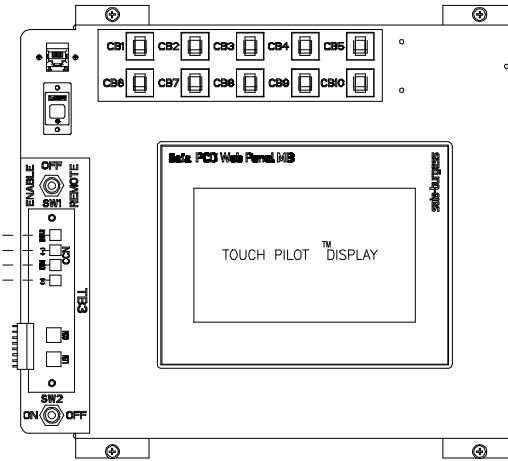
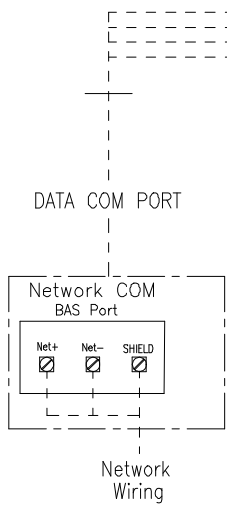

ITC CLASSIFICATION U.S. ECCN:EAR99	SHEET 1 OF 3	DATE 06/07/17	SUPERCEDES	30XV 140-500 AIR COOLED	30XV60002800	REV C
---------------------------------------	-----------------	------------------	------------	-------------------------	--------------	----------

Field Wiring Diagram for 225 Air Cooled Screw

Project: PAE - OSU Dixon Rec Ctr
 Prepared By: TZ Hristov

11/15/2018
 12:22AM

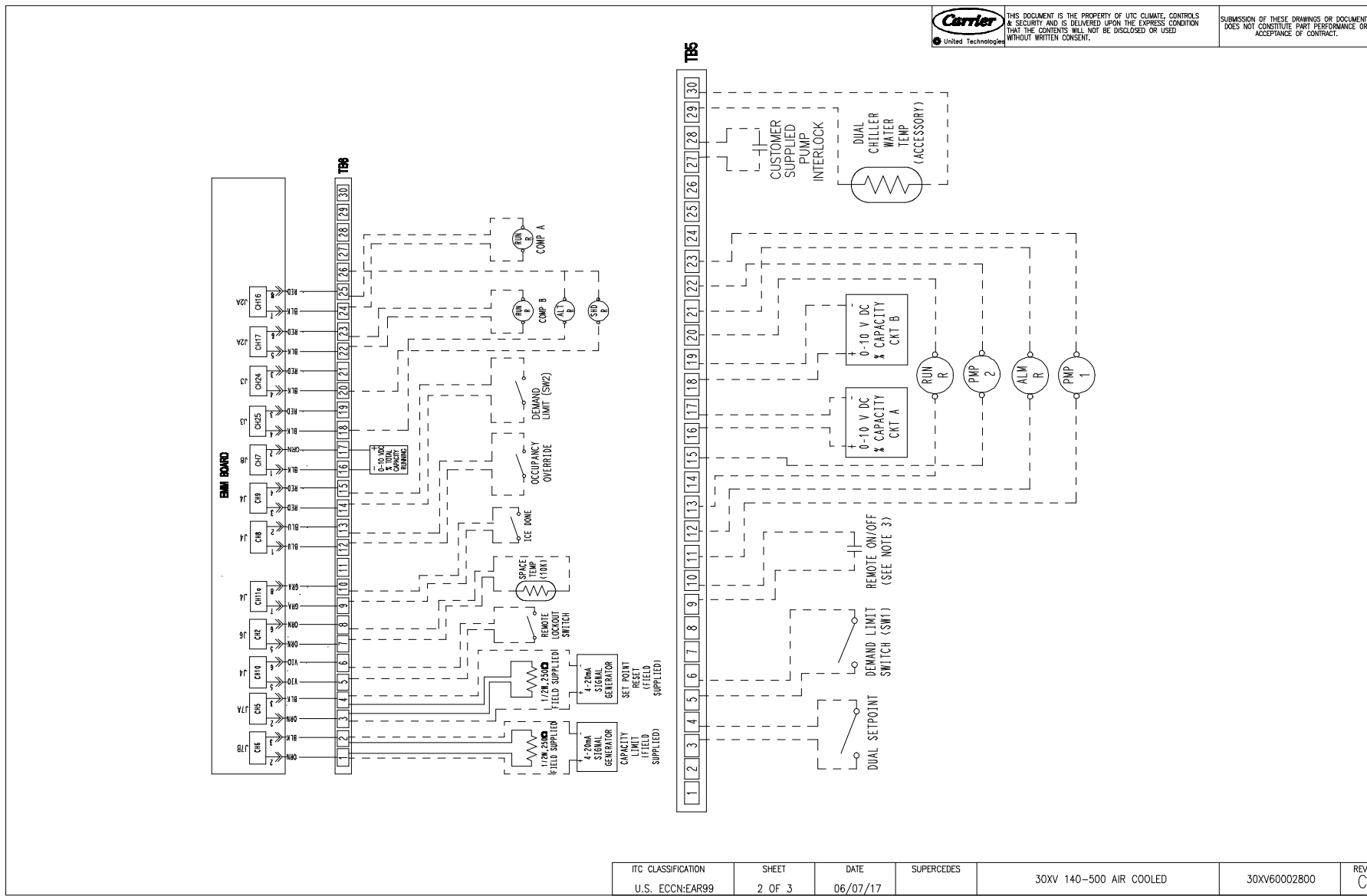

Field Wiring Diagram for 225 Air Cooled Screw

Project: PAE - OSU Dixon Rec Ctr
 Prepared By: TZ Hristov

11/15/2018
 12:22AM



THIS DOCUMENT IS THE PROPERTY OF UTC CLIMATE, CONTROLS & SECURITY AND IS DELIVERED UPON THE EXPRESS CONDITION THAT THE CONTENTS WILL NOT BE DISCLOSED OR USED WITHOUT WRITTEN CONSENT.

SUBMISSION OF THESE DRAWINGS OR DOCUMENTS DOES NOT CONSTITUTE PART PERFORMANCE OR ACCEPTANCE OF CONTRACT.

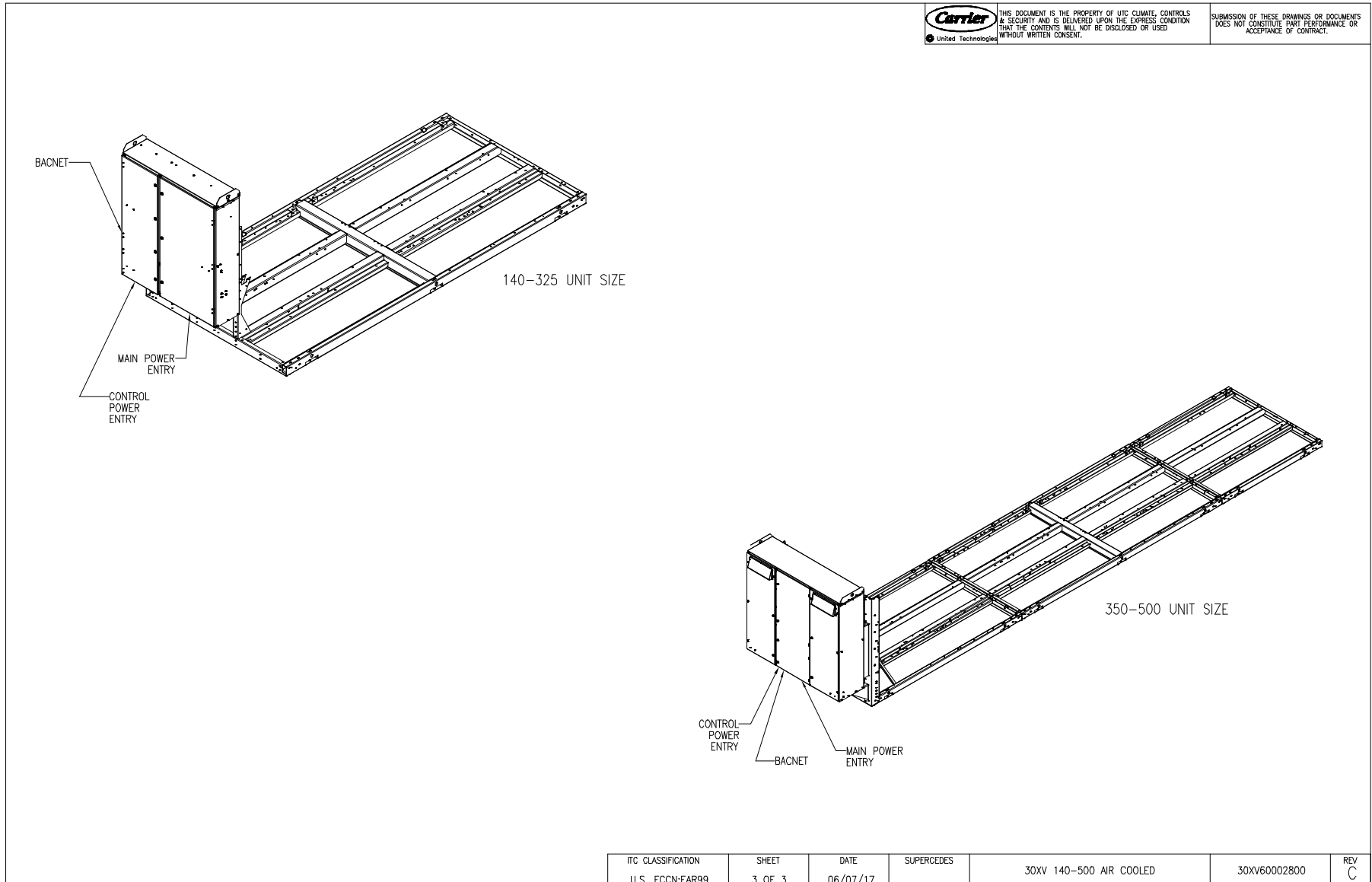

ITC CLASSIFICATION	SHEET	DATE	SUPERCEDES	30XV 140-500 AIR COOLED	30XV60002800	REV
U.S. ECCN:EAR99	3 OF 3	06/07/17				C

Detailed Performance Summary For 225 Air Cooled Screw

Project: PAE - OSU Dixon Rec Ctr
Prepared By: TZ Hristov

11/15/2018
12:22AM



AquaForce™ Air-Cooled Variable Speed Screw Chiller



Unit Information

Tag Name:..... **225 Air Cooled Screw**
Model Number:..... **30XV225S**
Condenser Type:..... **Air Cooled**
Compressor Type:..... **VFD Screw**
Nameplate Voltage:..... **460-3-60** V-Ph-Hz
Quantity:..... **1**
Manufacturing Source:..... **Charlotte, NC USA**
ASHRAE 90.1:..... **2013/2016, 2010, 2007**
Refrigerant:..... **R-134a**
Minimum Capacity:..... **15.00** %
Shipping Weight:..... **12902** lb
Operating Weight:..... **13185** lb
Refrigerant Weight (Circuit A):..... **175** lb
Refrigerant Weight (Circuit B):..... **135** lb
Unit Length:..... **252** in
Unit Width:..... **88** in
Unit Height:..... **99** in
Required Pad Length:..... **235** in
Minimum Outdoor Operating Temp:..... **-20.0** °F

Performance Information

Cooling Capacity:..... **216.1** Tons
Total Compressor Power:..... **241.4** kW
Total Fan Motor Power:..... **15.66** kW
Total Unit Power (without pump):..... **261.3** kW
Efficiency (without pump) (EER):..... **9.925** BTU/Wh

Evaporator Information

Fluid Type:..... **Fresh Water**
Fouling Factor:..... **0.000100** (hr-sqft-F)/BTU
Leaving Temperature:..... **44.00** °F
Entering Temperature:..... **58.00** °F
Fluid Flow:..... **369.3** gpm
Fluid Flow Min:..... **257.0** gpm
Fluid Flow Max:..... **1,066** gpm
Pressure Drop:..... **7.93** ft H2O

Condenser Information

Altitude:..... **0.000** ft
Number of Fans:..... **10**
Total Condenser Fan Air Flow:..... **145,000** CFM
Entering Air Temperature:..... **95.0** °F

Detailed Performance Summary For 225 Air Cooled Screw

Project: PAE - OSU Dixon Rec Ctr
Prepared By: TZ Hristov

11/15/2018
12:22AM

Integrated Pump Information

No Pump Selected

Accessories and Installed Options

Control Transformer
Non-Fused Disconnect
Flooded Evaporator, 2 pass, with heater
Variable Speed Condenser Fans
BACnet / Modbus Translator
Coil Trim Panels
Low Ambient Head Pressure Control
Standard Tier

Electrical Information

Unit Voltage:.....**460-3-60** V-Ph-Hz
Connection Type:.....**Single Point**
Minimum Voltage:.....**414** Volts
Maximum Voltage:.....**506** Volts

Amps	Electrical Circuit 1	Electrical Circuit 2
MCA	421.1	---
MOCP	600.0	---
Rec Fuse Size	500.0	

Detailed Performance Summary For 225 Air Cooled Screw

Project: PAE - OSU Dixon Rec Ctr
 Prepared By: TZ Hristov

11/15/2018
 12:22AM

Integrated Part Load Value (AHRI)

IPLV.IP:.....18.73 BTU/Wh

Unit Performance				
Percent of Full Load Capacity, %	100.00	75.00	50.00	25.00
Percent of Full Load Power, %	100.00	50.89	23.67	9.61
Unloading Sequence	A	A	A	A
Cooling Capacity, Tons	215.7	161.7	107.8	53.91
Total Unit Power, kW	261.3	133.0	61.86	25.12
Efficiency (EER), BTU/Wh	9.904	14.60	20.92	25.76
Evaporator Data				
Fluid Entering Temperature, °F	54.00	51.49	48.99	46.50
Fluid Leaving Temperature, °F	44.00	44.00	44.00	44.00
Fluid Flow Rate, gpm	515.8	515.8	515.8	515.8
Fouling Factor, (hr-sqft-F)/BTU	0.000100	0.000100	0.000100	0.000100
Condenser Data				
Entering Air Temperature, °F	95.0	80.0	65.0	55.0

Nonstandard Part-Load Value

NPLV.IP:.....18.74 BTU/Wh

Unit Performance				
Percent of Full Load Capacity, %	100.00	75.00	50.00	25.00
Percent of Full Load Power, %	100.00	50.96	23.71	9.65
Unloading Sequence	A	A	A	A
Capacity, Tons	216.1	162.1	108.1	54.03
Total Unit Power, kW	261.3	133.1	61.94	25.22
Efficiency (EER), BTU/Wh	9.925	14.61	20.93	25.70
Evaporator Data				
Fluid Entering Temperature, °F	58.00	54.48	50.99	47.49
Fluid Leaving Temperature, °F	44.00	44.00	44.00	44.00
Fluid Flow Rate, gpm	369.3	369.3	369.3	369.3
Fouling Factor, (hr-sqft-F)/BTU	0.000100	0.000100	0.000100	0.000100
Condenser Data				
Entering Air Temperature, °F	95.0	80.0	65.0	55.0

Detailed Performance Summary For 225 Air Cooled Screw

Project: PAE - OSU Dixon Rec Ctr
Prepared By: TZ Hristov

11/15/2018
12:22AM

Load Line

Unit Performance										
Percent Full Load Capacity, %	100.00	90.00	80.00	70.00	60.00	50.00	40.00	30.00	20.00	12.50
Percent of Full Load Power, %	100.00	78.56	62.33	49.12	38.06	28.79	20.73	14.17	8.93	4.96
Unloading Sequence	A	A	A	A	A	A	A	A	A	A
Capacity, Tons	216.1	194.5	172.9	151.3	129.7	108.1	86.44	64.83	43.22	27.01
Total Unit Power, kW	261.3	205.3	162.8	128.3	99.45	75.22	54.16	37.02	23.33	12.97
Efficiency (EER), BTU/Wh	9.925	11.37	12.74	14.15	15.65	17.24	19.15	21.02	22.23	25.00
Evaporator Data										
Fluid Entering Temperature, °F	58.00	56.58	55.18	53.78	52.38	50.99	49.59	48.19	46.79	46.30
Fluid Leaving Temperature, °F	44.00	44.00	44.00	44.00	44.00	44.00	44.00	44.00	44.00	44.00
Fluid Flow Rate, gpm	369.3	369.3	369.3	369.3	369.3	369.3	369.3	369.3	369.3	369.3
Fouling Factor, (hr-sqft-F)/BTU	0.000100	0.000100	0.000100	0.000100	0.000100	0.000100	0.000100	0.000100	0.000100	0.000100
Condenser Data										
Entering Air Temperature, °F	95.0	91.0	87.0	83.0	79.0	75.0	71.0	67.0	63.0	59.0

An uncoated Novation condenser coil was selected for this product. This is based on an installed location with postal code 97503 and a non-corrosive localized environment. Sound power measured in accordance with ANSI/AHRI Standard 370-2015.



Certified in accordance with the AHRI Air-Cooled Water-Chilling Packages Certification Program, which is based on AHRI Standard 550/590 (I-P) and AHRI Standard 551/591 (SI). Certified units may be found in the AHRI Directory at www.ahrirectory.org.

The NPLV is not an AHRI 550/590 metric and is not certified. It is based on ambient temperature varying linearly from the full load ambient to 55 F at 0% load.

Detailed Performance Summary For 225 Air Cooled Screw

Project: PAE - OSU Dixon Rec Ctr
Prepared By: TZ Hristov

11/15/2018
12:22AM

Unit Parameters

Tag Name:..... **225 Air Cooled Screw**
 Model Number:..... **30XV225**
 Condenser Type:..... **Air Cooled**
 Compressor Type:..... **VFD Screw**
 Chiller Nameplate Voltage:..... **460-3-60** V-Ph-Hz
 Quantity:..... **1**
 Manufacturing Source:..... **Charlotte, NC USA**
 Refrigerant:..... **R-134a**
 Shipping Weight:..... **12902** lb
 Operating Weight:..... **13185** lb
 Refrigerant Weight (Circuit A):..... **175** lb
 Refrigerant Weight (Circuit B):..... **135** lb
 Unit Length:..... **252** in
 Unit Width:..... **88** in
 Unit Height:..... **99** in
 Required Pad Length:..... **235** in

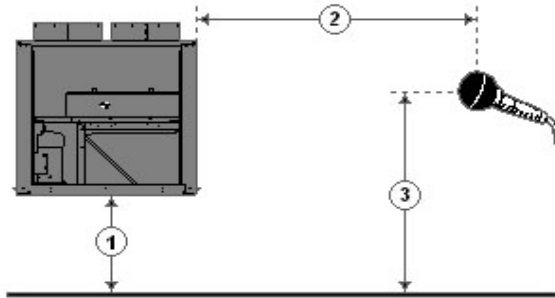

1 - Chiller Height Above Ground
 2 - Horizontal Distance From Chiller to Receiver
 3 - Receiver Height Above Ground
 (See Note 3)

Accessories and Installed Options

Control Transformer
 Non-Fused Disconnect
 Flooded Evaporator, 2 pass, with heater

Variable Speed Condenser Fans
 BACnet / Modbus Translator
 Coil Trim Panels

Acoustic Information

Table 1. A-Weighted Sound Power Levels (dB re 1 picowatt). See note #1.

Octave Band Center Frequency, Hz	63	125	250	500	1k	2k	4k	8k	Overall
100% Load	64	78	82	93	95	96	90	79	100
75% Load	62	75	80	90	89	87	79	73	94
50% Load	59	70	79	84	85	80	71	70	89
25% Load	55	64	74	79	77	72	65	66	83

Table 2. A-Weighted Sound Pressure Levels (dB re 20 micropascals) calculated based upon user defined input for dimensions 1, 2 and 3 as shown in above diagram. See note #2 and #3.

Octave Band Center Frequency, Hz	63	125	250	500	1k	2k	4k	8k	Overall
100% Load	32	45	50	61	63	63	58	46	68
75% Load	30	43	48	57	57	55	47	41	62
50% Load	27	37	47	51	52	48	39	38	56
25% Load	22	31	42	46	45	40	33	34	50

Notes: (1) Measurements performed in accordance with AHRI Standard 370-2015 for air cooled Chillers.
 (2) Chiller is assumed to be a point source on a reflecting plane.

Detailed Performance Summary For 225 Air Cooled Screw

Project: PAE - OSU Dixon Rec Ctr
Prepared By: TZ Hristov

11/15/2018
12:22AM

(3) Without user defined input, the default dimensions used to construct Table 2 are as follows:

- 1 - Chiller Height Above Ground = 0.0 ft
- 2 - Horizontal Distance From Chiller to Receiver = 30.0 ft
- 3 - Receiver Height Above Ground = 3.0 ft