



**OREGON STATE UNIVERSITY
REQUEST FOR QUOTE (RFQ)**

		ISSUE DATE:	November 8, 2017
RFQ #	SF191818Q	RFQ DUE DATE:	November 15, 2017, 1:00 PM PT
DELIVER TO:		REQUESTED BY / RETURN QUOTE TO:	
DEPARTMENT:	Capital Planning and Development	NAME:	Shannon Fanourakis
ADDRESS:		E-MAIL:	Shannon.Fanourakis@oregonstate.edu
CITY, STATE ZIP:	Corvallis, OR 97333	TELEPHONE:	(541) 737-6995
REQUIRED DELIVERY DATE:	January 31, 2018	FAX:	(541) 737-2170

ITEM	DESCRIPTION	QTY	UNIT	UNIT PRICE	TOTAL PRICE
	Fabrication of bollards for Reser Stadium for security purposes, per attached drawings, as follows:				
1	Standard Bollards	144	Ea		
2	Removable Bollards	7	Ea		
3	In Ground Sleeve for Removable Bollards	7	ea		
	Please Note: This is for bollard fabrication only and not for installation				

Delivery is f.o.b. destination, prepaid and allowed. Shipping, freight and handling must be included in quoted prices. Additional costs for such are disallowed. **TOTAL**

DELIVERY TIME AFTER RECEIPT OF ORDER: _____ **PRICES VALID THROUGH:** _____

SPECIAL INSTRUCTIONS:	VENDOR INFORMATION:		
1. Unless otherwise specified, all items quoted are to be new, unused and not remanufactured in any way. 2. Brand names are for the purpose of describing and establishing the characteristics desired and are not intended to limit or restrict competition. Quoters may submit quotes for substantially equivalent products unless the RFQ provides that a specific brand is necessary because of compatibility requirements, etc. All such brand substitutions shall be subject to approval by OSU. 3. Quoters must clearly identify all products quoted. Brand name and model or number must be shown. 4. Only documents issued as addenda by OSU serve to change the RFQ in any way. 5. OSU reserves the right to make the award by item, partial or whole lots, groups of items or entire quote, whichever is in the best interest of OSU. 6. OSU may reject any Quote not in compliance with the RFQ, attachments, and addenda, or if it is in the best interest of OSU. 7. This RFQ form must be completed, signed and returned with all required documents.	COMPANY:		
	ADDRESS:		
	CITY, STATE, ZIP:		
	CONTACT NAME:		
	E-MAIL:		
	TELEPHONE:		
	FAX:		
	VENDOR SIGNATURE: <i>By signature below the undersigned certifies that they are authorized to act on behalf of the quoter and will comply with all aspects of the quote herein.</i>		
	SIGNATURE:		
	NAME/TITLE:		

This procurement is subject to the indicated Oregon State University Standard Terms and Conditions for: Goods Services Purchase Order Construction Software. The indicated terms and conditions may be viewed at <http://pacs.oregonstate.edu/terms-and-conditions>

STANDARD BOLLARD (144 TOTAL)

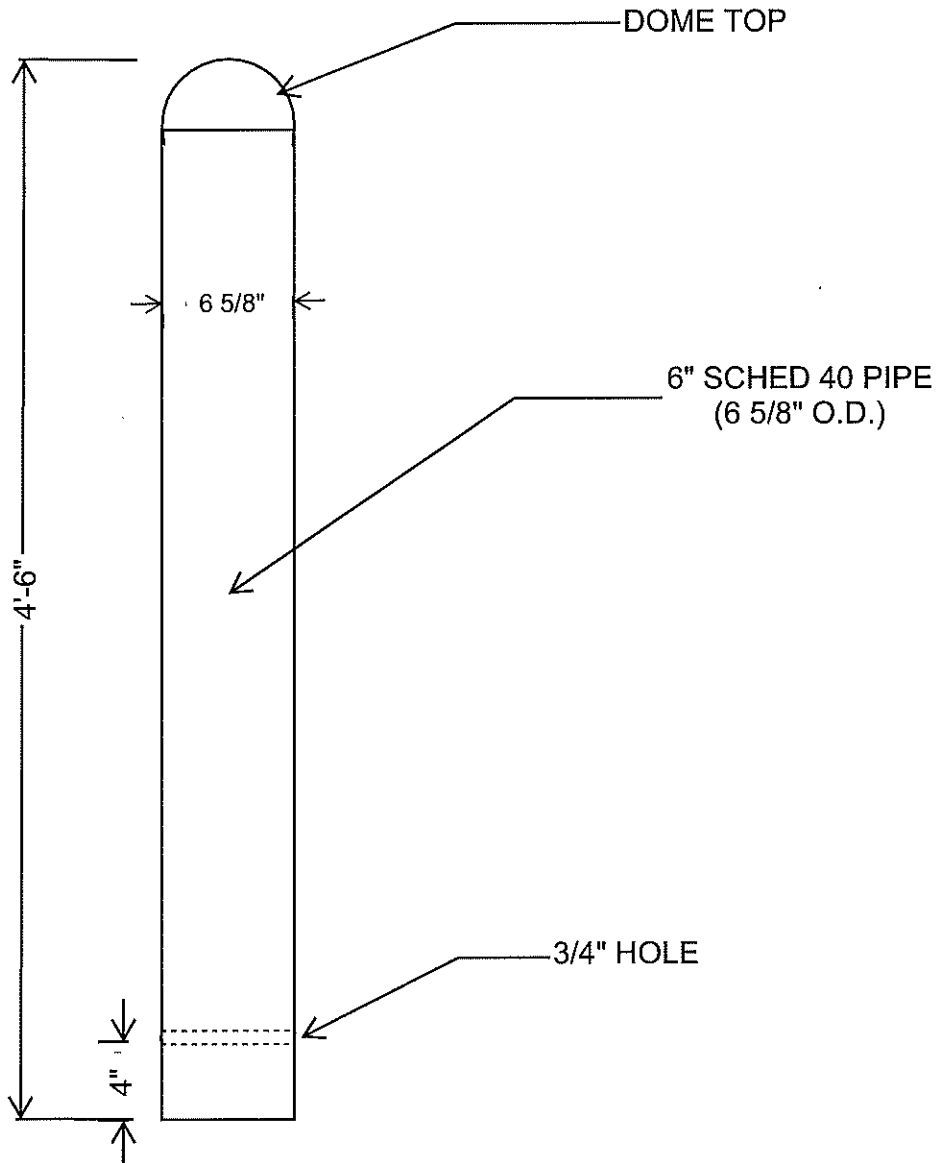

NTS

REMOVABLE BOLLARD (7 TOTAL)

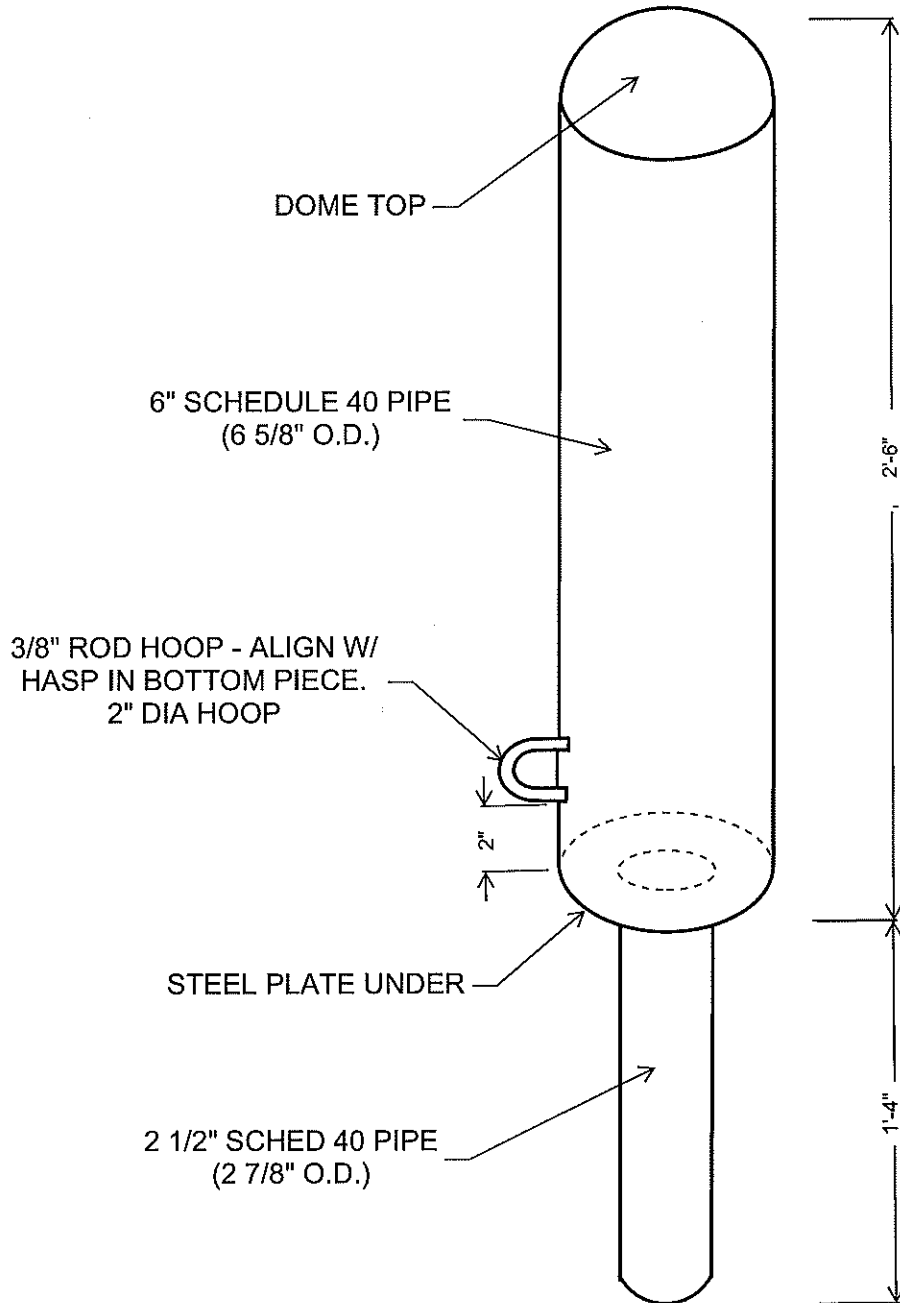

NTS

REMOVABLE BOLLARD IN-GROUND SLEEVE
(7 TOTAL)

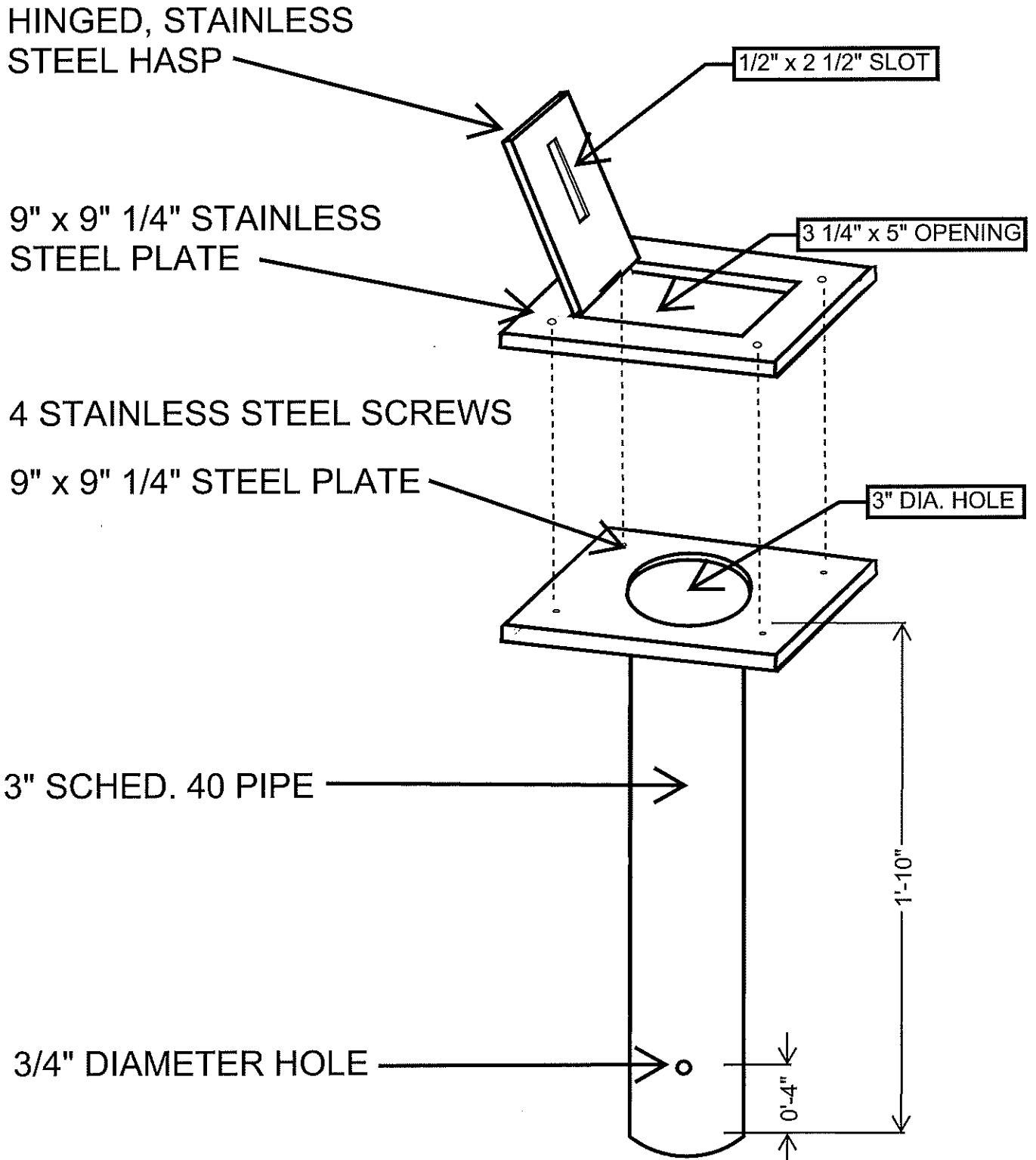

NTS