

Templifier® Heat Recovery Water Heaters

Model TGZ, Scroll Compressor, 600 to 3,100 MBH (175 to 900 kW)

Model TSC, Centrifugal, 3,000 to 24,000 MBH (880 to 7,000 kW)

R-134a

50/60 Hertz





Templifier Model TGZ 120 with standard four-pass condenser. Heating capacity of 1,800 MBH at 140°F leaving hot water and 75°F leaving source water. Shown less piping insulation for clarity.

MODEL CODE

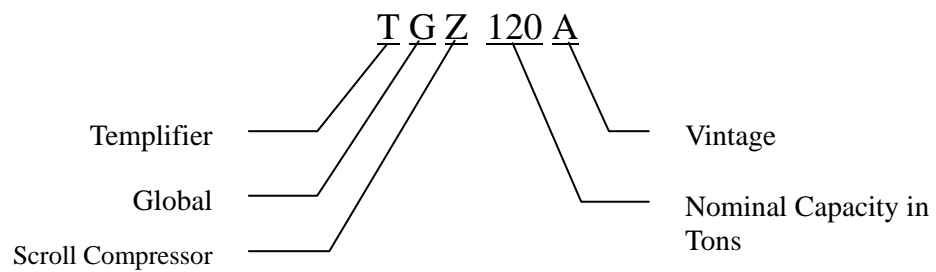

Table of Contents

Introduction	3
Economic Evaluation	5
Templifier Unit Description.....	7
Model TGZ - Scroll Compressor Templifier Units	7
TSC Centrifugal Compressor Templifier Units.....	9
Application.....	14
General	15
TGZ Operating Limits.....	15
Waste Heat (Source Water) Side	17
Water Heating Side	20
Environmental Impact.....	23
Selection Procedure.....	25
TGZ Scroll	25
TSC Centrifugal	26
TGZ Capacity Adjustment Factors	27
Performance Data	28
TGZ Scroll	28
Pressure Drop Data	32
TGZ Scroll	32
TGZ Electrical Data.....	35
TSC Electrical Data	45
TSC Motor Starters.....	46
Physical Data	47
TGZ Scroll	47
TGZ Dimensional Data	51
Weights.....	59
Sound Data.....	60
TGZ Sound Data	60
Options	61
TGZ Scroll Templifier	61
TSC Centrifugal Templifiers.....	63
Guide Specifications.....	64
TGZ Scroll	64
TSC Centrifugal Templifier	70

Manufactured in an ISO Certified Facility

Document:	CAT Templifier-1
Issue Date:	January 2009
Revised	December 2009
Replaces:	CAT Templifier
McQuayTools PDC version:	7.87

©2008 McQuay International. Illustrations and data cover the McQuay International product at the time of publication and we reserve the right to make changes in design and construction at anytime without notice. ™® The following are trademarks or registered trademarks of their respective companies: BACnet from ASHRAE; LONMARK, LonTalk, LONWORKS, and the LONMARK logo are managed, granted and used by LONMARK International under a license granted by Echelon Corporation; Modbus from Schneider Electric; MicroTech II, Open Choices, Energy Analyzer, and Templifier from McQuay International .

Introduction

What Is It?

Templifier Heat Pump Water Heaters are designed to economically turn waste heat into useful heat. They are non-reversible, water-to-water, Carnot cycle heat pumps. Waste heat is extracted from a fluid stream by cooling it in the evaporator, the compressor amplifies the temperature of the heat and the condenser delivers the now useful heat to heating loads such as space heating, domestic hot water heating and process loads.

They can also be switched over (unit and piping) to perform as conventional water chillers, controlling the chilled water temperature and rejecting heat to a cooling tower.

Templifier units are versatile in their application. Instead of recovering wasted heat, they can produce chilled water while they're heating. They are first and foremost economic machines, providing heat at a lower cost than fossil fuels and realizing a very attractive return on investment.

How Does It Work?

Commercial and institutional buildings throw away vast amounts of rejected heat from the air-conditioning load to the atmosphere through their cooling towers. To obtain maximum efficiency from the chillers, the tower water temperature is maintained as low as possible (within certain operational limitations). The tower water temperature range of about 60°F to 95°F (15°C to 35°C) precludes the use of this warm water for other purposes such as domestic water and space heating.

Likewise, industrial processes also discharge large quantities of low grade waste heat to cooling towers and other heat sinks, in both open and closed heat rejection systems.

Figure 1, Typical TSC Templifier Unit Flow Diagram

NOTE: Models TGZ 040 through TGZ 120 require an intermediate heat exchanger between the tower water and the evaporator.

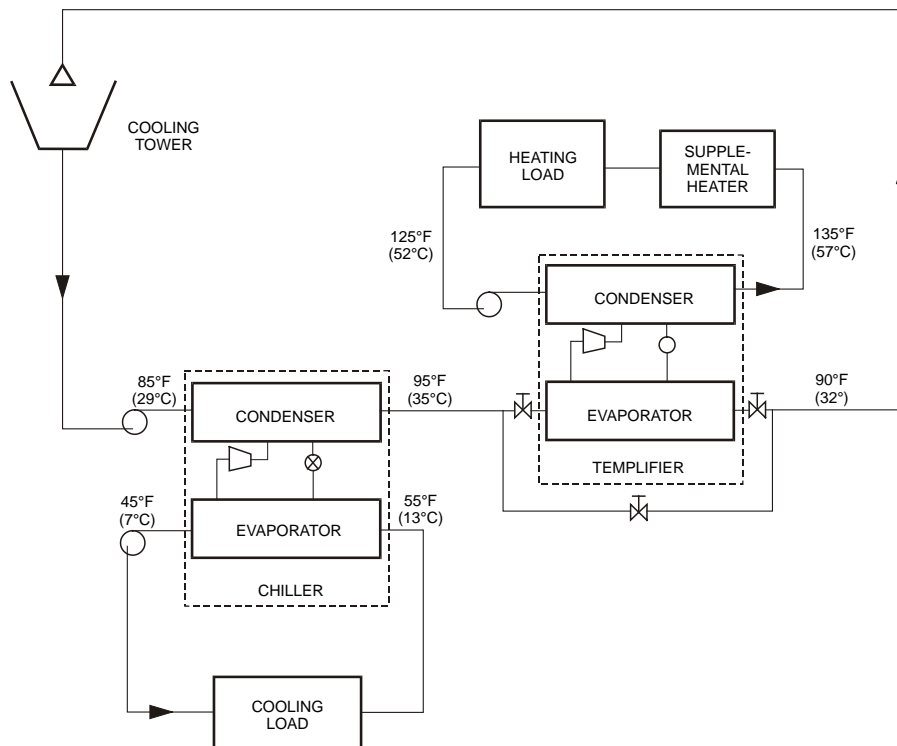

Where to Use Templifier Units

HVAC Applications

Building Types		Applications	
Hotels/Motels	Schools	Space Heating	Service Hot Water
Health Care	Food Service	Outside Air Heating	Laundries
Athletic Facilities	Nursing Homes	Reheat	Kitchens
Resorts			

Process Applications

Food Processing	Quench Tanks	Process Hot Water	Space Heating
Textiles	Air Compressors	Washing/Rinsing	Service Water
Paper Mills	Effluents	Dehumidifying	Preheat Feed Water
Geothermal	Solar Collectors	Outside Air Heating	

COP and the Multiplying Effect

Coefficient of Performance (COP) is defined as the useful energy output of a Templifier unit divided by electric energy input, all expressed in the same units of measure. Put another way, 4 units of waste heat in, plus 1 unit of purchased electrical energy input equals 5 units of useful heat out - a COP of 5. Electric resistance heat has a COP of 1, buy 1 unit of electricity and you get one unit of heat out. In this example, the Templifier unit is 5 times more efficient, requiring one-fifth the energy.

Why Consider a Templifier Unit?

The primary purpose of a Templifier unit is to heat water more economically than fossil fired boilers or electric resistance heaters, and thereby achieve an acceptable return on the investment.

A secondary benefit is that a Templifier unit can off-load overloaded boilers and/or cooling towers, thereby delaying, reducing or eliminating a capital expenditure required to increase their capacity or system efficiency.

A Templifier unit in the return chilled water line will off-load a chiller plant, producing chilled water at a very low cost. The Templifier unit is an electric-driven water heater with an attractive, higher COP than resistance heat, but with the potential to pay its own way by providing an acceptable Return on Investment (ROI) for the owner.

Advantageous Job Conditions

Certain job conditions will contribute to the economic viability of a Templifier unit:

- Relatively high fossil fuel costs and low electrical demand and energy costs.
- High heating and cooling load factors i.e. a high number of high load hours of use. When recovering rejected heat from an air-conditioning system, this means a long cooling season or high internal cooling loads satisfied with mechanical cooling.
- Heating requirements coincident with cooling load to minimize or eliminate storage requirements.
- Situations where additional cooling is required in the summer and heating required in the winter.
- Warm source water temperatures to maximize COP.
- 24/7 process loads

Economic Evaluation

Introduction

Since Templifier units are usually purchased on the basis of their economic viability, the local McQuay sales representative can run a Templifier economic feasibility study. Use of the McQuay Energy Analyzer™ program will estimate the savings on a particular project. The annual heat output of the Templifier unit depends on the heating load profile and the coincident availability of waste heat, usually from the chilled water plant condenser water.

Evaluation Data

The following information will help make a reliable evaluation of how much a Templifier unit can save on a project:

- The heating load profile.
- The cooling load profile as far as the availability of waste heat from the air-conditioning system's condenser water. The temperature of the condenser water is important. During periods of cool ambient temperatures, the cooling tower will supply water colder than design conditions. The Templifier unit will consequently be operating with source water at lower than design temperature. This will result in a lower COP for the Templifier unit, but a better efficiency for the chiller which usually has the larger electric load. The COP will usually be fluctuating over the course of the day and season. When the cooling load is large compared to the Templifier unit's waste heat requirement, a cursory examination may be sufficient.
- The cost of fossil fuel used to fire the boiler that the Templifier unit will be replacing (or electricity if resistant heaters are used).
- The cost of electricity to operate the Templifier unit.
- The Templifier unit installed cost. If the need for other equipment (such as additional cooling tower or boiler) is eliminated because of the Templifier unit, the avoided cost saving should be credited against the Templifier unit's cost.
- Financial information such as actual tax rate, cost of capital, analysis period and the owner's threshold payback or return on investment.

One to Two-Year Payback

Templifier units heat water with electricity instead of a fossil fuel. A Templifier unit offers both efficiency improvements and the advantage of a lower cost energy source than a boiler.

For example, a \$75,000 boiler can consume \$400,000 of fuel annually. When inefficiencies in the system are accounted for, boiler efficiencies rarely exceed 80%. Condensing boilers are better with efficiencies in the 95% range. However, even this improvement in efficiency is a distance second place to a Templifier unit. Templifier units easily offer COPs of 4 and higher. As a result, Templifier units often pay for themselves in one or two years. The fuel savings can create very attractive ROIs.

Using average North American energy prices, a Templifier unit operates at half the cost of a natural gas fired boiler. At a 50-percent heating load factor and a heating requirement of 6000 MBH, a Templifier unit offers annual savings of approximately \$200K in avoided fuel/operating costs over a boiler. This is substantial, but the savings potential can be greater when secondary effects are included.

If the return chilled water is used as the heating source, a Templifier unit will reduce the load on the chilled water plant. This reduced portion of the load is handled by the Templifier unit and the energy savings in the chiller plant should be credited to the Templifier unit. Additionally, heat recovered by a Templifier unit avoids water consumption in the cooling tower. Heat recovered is not heat rejected though evaporation. The savings come in the form of less make-up-water, lower treatment costs, and reduced sewer charges for disposing of blowdown. Credit should be given to the Templifier unit for these cost saving as well.

The economics of heat recovery is a compelling story, and should be carefully analyzed. Templifier units are an investment that can return many times their first cost over the life cycle of the installation. With present and forecasted energy markets, energy has become a strategic business issue. Templifier units can be an integral part of that strategy with a significant ROI.



TGZ 120 shown above with piping insulation removed for clarity

Templifier Units

- **Innovative heat recovery technology reduces energy cost and carbon footprint**
- **Can reduce CO₂ emissions by hundreds of tons annually**
- **HFC-134a refrigerant usage contributing to LEED**

Templifier Unit Description

Model TGZ - Scroll Compressor Templifier Units

The McQuay TGZ Scroll-Compressor Templifier units are a continuation of the successful McQuay Templifier line introduced in 1975. With a proven record of successful, dependable service, they feature reliable scroll compressors and the McQuay MicroTech[®] II microprocessor control system.

Compressors

Tandem or trio scroll compressors are used for a total of four or six compressors per unit (depending on unit size). These rugged hermetic compressors are constructed with an integral cast iron frame, cast iron scrolls, three Teflon[®] impregnated bearings, and three oil filtration devices for each compressor.

Using tandem or trio scroll compressors provides four or six steps of capacity modulation by cycling the compressors. Both of the refrigerant circuits have specially designed oil and gas equalization lines to control oil migration.

The design also offers radial and axial compliance (no tip seals), a large internal volume for liquid handling, a removable suction screen, and a rotary dirt trap and oil screen. In addition, the compressor is self-compensating for wear, handles liquid and debris, and inherently yields the highest efficiency for its class.

This well protected compressor includes a solid-state motor protection module, four individual motor-winding sensors, a patented internal discharge temperature probe, and a patented shutdown feature that prevents reverse rotation. An internal discharge check valve helps prevent shutdown noise and comes standard with high and low pressure taps with Schrader valves, a sight glass, an oil level adjustment valve, and an off cycle crankcase heater.

Units are available in 60-hertz with voltages from 208 to 575 volt, operating at 3500 RPM.

At start-up, a crankcase heater minimizes oil dilution by the refrigerant.

Factory Installed Piping Components

Each chiller's refrigerant circuit has a manual liquid line shutoff valve, one or two replaceable-core filter-driers (depending on size), solenoid valve, liquid line sight glass/moisture indicator, expansion valve and discharge line shutoff valve. Hot gas bypass is an available option.

Noise

All McQuay TGZ Templifier units are equipped with hermetic scroll compressors with inherently low sound levels. Optional insulated acoustical compressor blankets will further reduce sound levels.

Electrical Control Center

Templifier units are shipped with factory-wired operating and equipment protection controls and motor starting equipment, are operationally tested, and shipped ready for installation. All controls are centrally located in a control center with lockable doors.

Evaporator

Models TGZ 040 to 120 evaporators are a high efficiency, two-circuit, brazed-plate type heat exchanger consisting of parallel, copper brazed, stainless steel plates, with a design water-side pressure of 450 psig (3099 kPa).

Evaporators are designed and constructed according to, and listed by, Underwriters Laboratories (UL). The evaporators do not have vent or drain connections and they must be supplied in the field piping.

Models TGZ 150 to 200 have shell-and-tube evaporators with 150 psig (1033 kPa) water-side working pressure. Drain and vent connections are provided on the vessel. The evaporator and suction line are insulated.

Water-Heating Condensers

The TGZ insulated water-heating condensers are cleanable shell and tube type with water in the tubes and two refrigerant circuits in the shell side, divided by a vertical, midpoint partition. Each condenser circuit is capable of holding the circuit's refrigerant charge and each circuit has its own charging and relief valves.

The condenser is constructed with a carbon steel shell and seamless, integrally finned, high efficiency copper tubes, roller expanded into steel tubesheets. The water heads at each end have vent and drain connections and are removable. Also included is a liquid shutoff valve, purge valve, and relief valve per ANSI/ASHRAE Pressure Vessel Code, Section VIII. Water-side working pressure is 232 psig (1438 kPa). Standard condenser connections are located on the right end looking at the control panel. Left hand connections are available as an option. Four-pass water circuiting for Delta-Ts in the 20 to 40 degree range is standard. Two-pass condensers for Delta-Ts in the 10 to 20 degree range are optional.

Commissioning

Supervision of start-up by McQuay or factory-authorized and trained technicians is included on all Templifier units.

MicroTech II Controller

The MicroTech II controller on the TGZ Templifier units provides the flexibility and performance needed for a stand-alone unit as well as multiple units tied into a network system.

The MicroTech design will not only permit the Templifier unit to run more efficiently, but will also simplify troubleshooting if a system failure occurs. Every MicroTech controller is programmed and tested prior to shipment to help ensure a trouble-free start-up.

User-Friendly

The 12-key, touch-sensitive, membrane keypad and 32-character display makes the MicroTech II system especially user-friendly. Inch-pound or SI units are optionally available.

The controller menu structure is separated into three distinct categories, which provide the operator or service technician with a full description of current unit status, control parameters, and alarms. Security protection prevents unauthorized changing of the setpoints and control parameters.

The MicroTech II controller continuously performs self-diagnostic checks, monitoring all system temperatures, pressures and safeties, and will automatically shutdown a compressor, a refrigerant circuit of the entire unit should a fault occur. The cause of the shutdown will be retained in memory and can be easily displayed in plain English for operator review. The MicroTech controller can also retain and display the time the fault occurred and the operating conditions that were present at the time of the fault, which is an extremely useful feature for troubleshooting. In addition to displaying alarm diagnostics, the MicroTech controller also provides the operator with a warning of pre-alarm conditions.

Figure 2, Keypad/Display

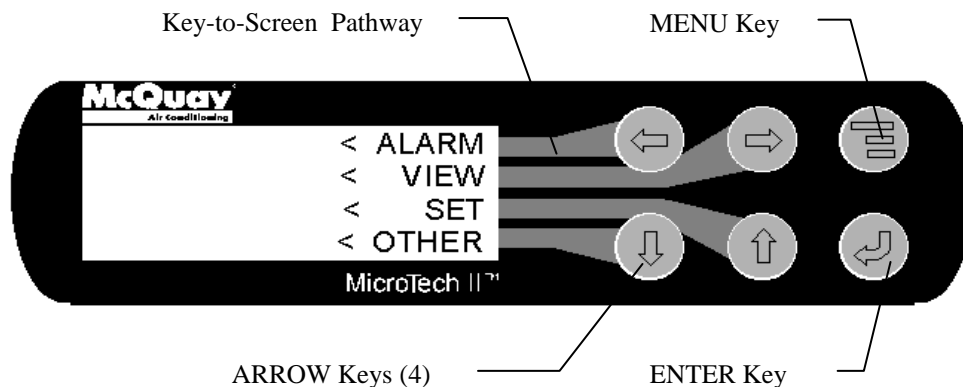

TSC Centrifugal Compressor Templifier Units

The McQuay Centrifugal Compressor Templifier units have been in use around the world since 1975. Continuous research and development have produced one of the most efficient, modern and reliable water-heating devices available in the market today. They can heat water to 136°F (58°C).

Compressor

Centrifugal compressor efficiency is largely a function of impeller design and the application to a specific refrigeration system. The McQuay gear-drive centrifugal Templifier units provide a variety of tip speed ratios to permit selection of impellers for maximum efficiency over their entire part load to full load range and are ideal for 50-Hz application. Mechanical gear losses are limited by design standards to less than one-half of 1%. The variety of impeller speeds obtained by alternate gear selections make the McQuay compressor uniquely suited to the wide range of operating conditions encountered in heat pump, water heating duty. The compressor can be specifically designed for job site conditions.



A motor draws locked-rotor current until it reaches approximately 80% of its running speed. While drawing locked-rotor current the stresses on the motor are over six times that of full load. The McQuay compressors minimize this stress through the unique gear drive and light weight drive train that allows most compressors to reach running speed in less than six seconds. The motors are cooled by liquid refrigerant, a technique particularly well suited to heat pump duty.

Lubrication System

A separately driven, electric oil pump assembly supplies lubrication at controlled temperature and pressure to all bearing surfaces and is the source of hydraulic pressure for the capacity control system.

The control system will not allow the compressor to start until oil pressure at the proper temperature is established, and also allows the oil pump to operate after compressor shutdown to assure lubrication during coast down.

Lubricant from the pump is supplied to the compressor through an external, water-cooled brazed-plate oil cooler and internal 5-micron oil filter. All bearing surfaces are pressure lubricated. Drive gears are operated in a controlled lubricated mist atmosphere that efficiently cools and lubricates them.

Lubricant is made available under pressure from the compressor oil filter to the unit capacity control system and is used to position the inlet guide vanes in response to changes in leaving condenser water temperature.

If a power failure occurs, an emergency oil reservoir provides lubrication flow under pressure and prevents damage that could occur during the spin down period with the oil pump stopped.

Figure 3, Lubrication System

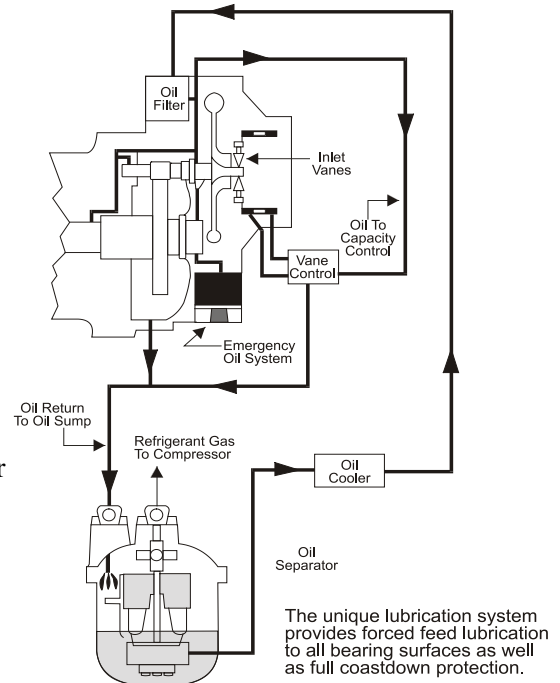

Shell-and-Tube Heat Exchangers

McQuay Templifier units are equipped with, high performance heat exchangers. The unique design greatly increases heat transfer and reduces unit footprint and refrigerant charge. Templifier units are designed, constructed and tested in accordance with ASME Section VIII and ASHRAE Standard 15 requirements.

The replaceable copper water tubes are internally and externally enhanced and are mechanically bonded to steel tube sheets. Standard tubes are 0.025 inch wall copper in the evaporator and condenser. Optional tubes include 0.028 inch and 0.035 inch copper in either vessel and 90/10 cupro-nickel, 304 stainless steel or titanium material. Clad tube sheets and epoxy-coated heads are included when other than copper tubes are specified.

Both vessels are available for 1, 2 or 3 pass water flow. A 3/4" thick vinyl/nitrate polymer condenser insulation is standard on both vessels. All seams are glued to form an effective vapor barrier.

Pumpdown/Pumpout

Pumpout systems provide a means to collect and contain the refrigerant charge with minimum loss, when the access to internal components is required for service.

McQuay condensers are sized to hold the entire unit refrigerant charge when not more than 90% full at 90°F (32°C) ambient temperature. They are equipped with a tight-seating check valve at the hot gas inlet and a manual shutoff valve in the liquid outlet. These valves, coupled with the condenser design, satisfy the stringent requirements of the U.S. Department of Transportation for refrigerant shipping containers, as well as ASME vessel codes.

When service is required, the refrigerant charge can be pumped down into the condenser by compressor operation and use of a refrigerant transfer unit. Elimination of the cost and space requirements of an external pumpout system is a major McQuay advantage.

Templifier Units Feature MicroTech II® Controls

McQuay has incorporated the latest microprocessor technology into the MicroTech II control system to give you the ultimate in unit control. The control includes many energy-saving features to keep your unit running efficiently, day in, day out, for years to come.

Figure 4, Unit Controller & Operator Interface Touchscreen

The unit controller and operator interface touchscreen, mounted on a Templifier unit are shown to the right. The 15-inch VGA touch screen is on an adjustable arm so that it can be positioned comfortably for each operator. The unit control panel contains a USB port from which trend data and manuals can be conveniently downloaded. All-important unit operating data is easily accessed and viewed. Password protected unit setpoints, complete with description and setting range, are available at the touch of a screen.



Figure 5, Compressor Controller

A major feature of the MicroTech II controller is the distributive control scheme. The picture to the right shows the compressor control panel (with cover removed) mounted at the rear of the unit, adjacent to the compressor itself. This panel also contains the oil pump contactor and overload. Also on the pLAN (control network) is the unit controller and operator interface touch screen. If the interface touch screen and/or unit controller (600-ton units and above), is out of service, the unit can continue to operate on the compressor controller alone. This feature provides unprecedented reliability in a control system.



MicroTech II Features and Benefits	
FEATURE	BENEFIT
Easy integration into building management system via McQuay's exclusive Open Choice™ feature.	Designer can to select any BAS supplier using industry standard protocols and know the MicroTech II control will easily interface with it.
Easy to read, adjustable, 15-inch, Super VGA color touchscreen operator interface	Operators can observe chiller operation at a glance, easily select detail screens and change setpoints
Historic trend data-can be downloaded via USB	Water temperatures, refrigerant pressures, and motor load plots can provide valuable unit operation data
Precise ± 0.2 °F chilled water control	Provides stability in the water system
Proactive pre-shutdown correction of "unusual conditions" allows unit to stay online	Activates alarm and modifies chiller operation to provide maximum possible cooling
Automatic control of hot water and source water pumps, if desired	Integrated lead/lag and automatic engagement of backup pump
25 previous alarm descriptions stored in memory	Invaluable asset in troubleshooting
Multiple language capability, metric or in-lb units of measure	Great asset for world-wide applications

Designed with the System Operator in Mind

Reliable, economic use of any unit depends largely on an easy operator interface. That's why operation simplicity was one of the main considerations in the development of the MicroTech II controller. The operator interface with the unit is a 15-inch, Super VGA color touch-screen. The operator can clearly see the entire unit graphically displayed, with key operating parameters viewable on the screen. Other screens, such as alarm history and set points, are easily accessed through touch screen buttons.

For added convenience the unit operating and maintenance manual is installed in the chiller's microprocessor memory, so that they are viewable on the touchscreen or can be downloaded to a computer through the onboard USB port.

Proactive Control

By constantly monitoring unit status, the MicroTech II controller will automatically take proactive measures to relieve abnormal conditions or shut the unit down if a fault occurs. For example, if a problem occurs in the source water and suction pressure starts to drop, the controller will automatically hold the load point and activate an alarm signal. A further drop in pressure will initiate compressor

unloading in an effort to maintain the setpoint pressure. If the pressure continues to drop, the unit will shut off at the cutout pressure setting.

Alarm History for Easy Troubleshooting

The MicroTech II controller's memory retains a record of faults and a time/date stamp. The controller's memory (no batteries required) can retain and display the cause of the current fault and the last twenty-five fault conditions. This method for retaining the fault is extremely useful for troubleshooting and maintaining an accurate record of unit performance and history.

The MicroTech II controller features a three-level password security system to provide protection against unauthorized use.

Figure 6, MicroTech II Controller Home Screen

The Home Screen shown to the right is the primary viewing screen. It gives real time data on unit status, water temperatures, chilled water setpoint and motor amp draw. This display answers the vital question of whether the unit is doing what it is supposed to be doing?

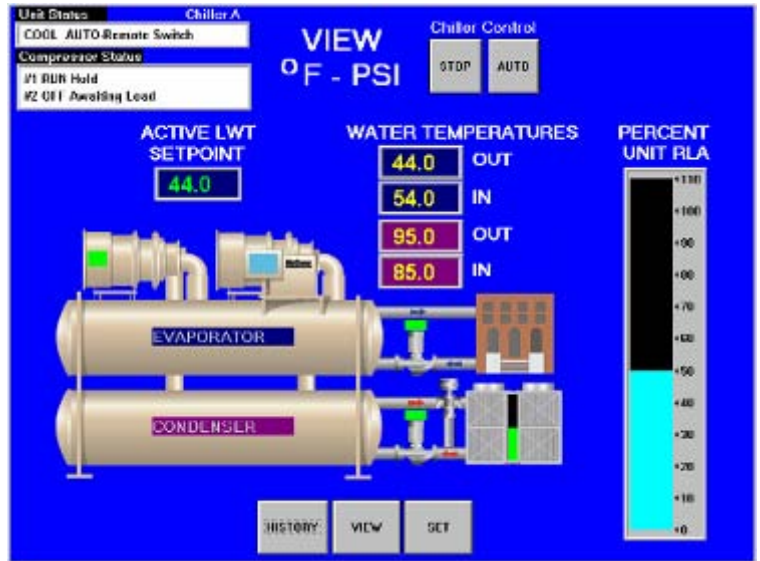

If an alarm occurs, a red button appears on the screen (a remote signal is also available). Pressing this button accesses the Active Fault Screen that gives complete fault information. Once the problem is resolved, the fault can be quickly and easily cleared.

Changing Setpoints

Changing setpoints is easy with the McQuay MicroTech II control. Setpoints are grouped by type in the right-hand column. Pressing one of them will display the group's individual setpoints.

For example, to change the hot water set point, press SET from any screen, then press the WATER button and this screen appears, press button #1, Leaving Water Temperature, and you are ready to input a password and then a new value.

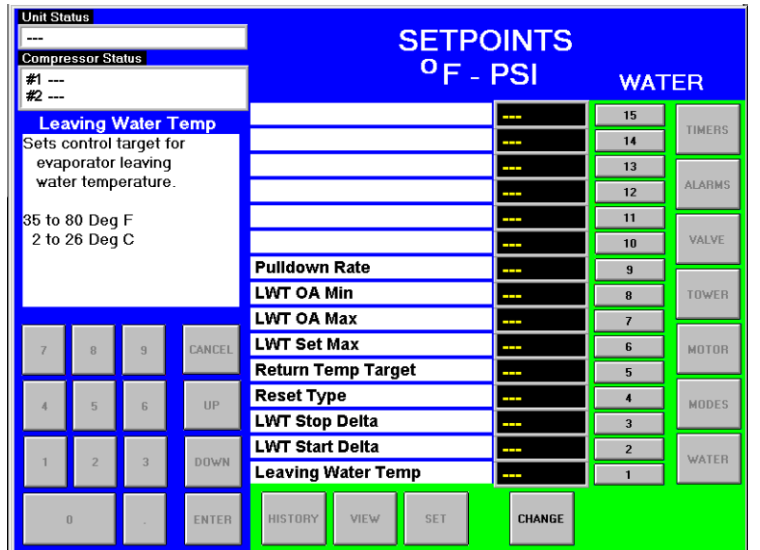

Trend Logging

Ever wonder how your unit performed last week? Were you holding the correct hot water temperature? What kind of heating load did the chiller have?

Thanks to its huge memory, the McQuay MicroTech II controller can provide the answers, and plot water temperatures, refrigerant pressures, and motor load data. These values can also be downloaded through a convenient USB port, located in the unit control panel, and pasted into a spreadsheet for archiving or further detailed evaluation.

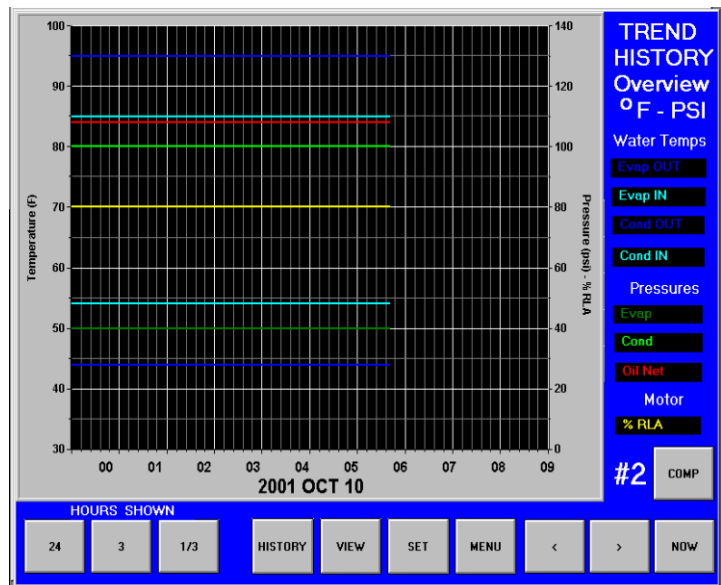

MicroTech II Controller Increases Chiller Operating Economy

Many standard features have been incorporated into MicroTech II control in order to maintain the operating economy of McQuay Templifier units. In addition to replacing normal relay logic circuits, we've enhanced the controller's energy saving capabilities with the following features:

- User-programmable compressor soft loading. Prevents excessive power draw during pull down from high chilled water temperature conditions.
- Demand limit control. Maximum motor current draw can be set on the panel, or can be adjusted from a remote 4-20ma or 1-5 VDC BAS signal. This feature controls maximum demand charges during high usage periods.
- Plotting Historic Trends. Past operation of the chiller can be plotted as trend lines and even downloaded to spread sheets for evaluation-a valuable tool for optimizing efficiency.

Application

Figure 7, Piping Schematic, Models TGZ 040 – 120

R332541601 Rev.00
Package Templifier
(Sheet 1)

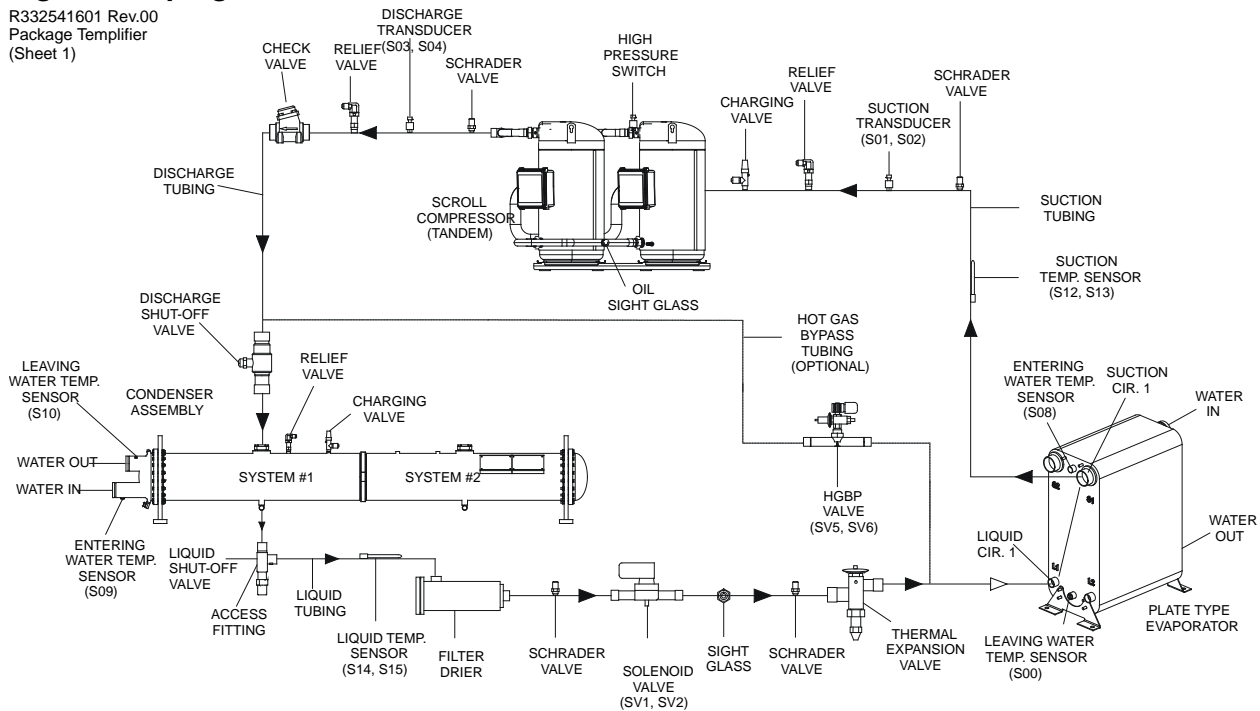
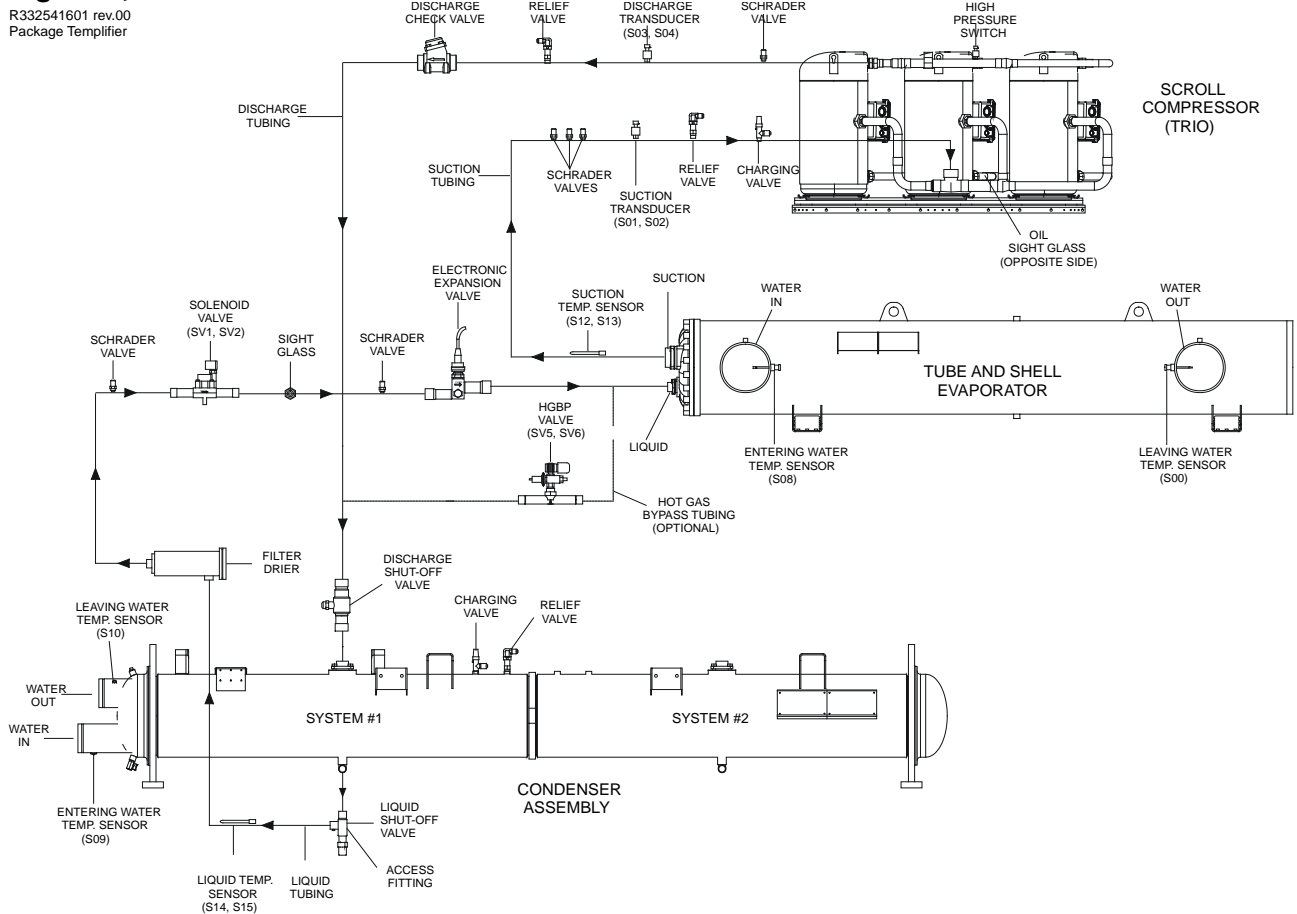

Figure 8, Models TGZ 150 - 190

R332541601 rev.00
Package Templifier



General

A Templifier unit is controlled by the heating load as sensed at the leaving hot (condenser) water connection. The amount of cooling done in the evaporator is uncontrolled and is a result of the amount of cooling required to meet the heating load. If there is insufficient waste heat for the unit to meet the heating load, the Templifier unit will begin to pull down the waste heat temperature, i.e. the evaporator water temperature will drop. Templifier units are equipped with a low source water temperature over-ride control feature. The control unloads the unit to prevent the leaving evaporator temperature from falling below a predetermined setpoint. This occurrence basically means that there is insufficient waste heat to support the heat load requirements. Consequently the hot water temperature will fall since the heating load is larger than the Templifier unit output. Supplementary heat is activated at this point to make up the heat difference.

This is an important concept. The heating load requirements over time, the concurrent availability of waste heat, and the size and control of a supplementary heater must be coordinated.

Model TGZ, scroll compressor Templifier units can also operate as conventional chillers, by moving a panel-mounted switch from Heat to Cool. An external BAS digital input signal can also be used.

TGZ Operating Limits

Templifier units are designed to operate over a wide range of temperatures so as to have wide application possibilities. The following operating limits are based on vessel and compressor limits.

Figure 9 gives the operating envelope for TGZ units. "OK" area is on the edge of the envelope and care should be exercised to not exceed the temperature limits during operation, n/a are not available operating points.

Figure 9, TGZ Operating Envelope

EVAP LWT TEMP.	CONDENSER LEAVING WATER TEMPERATURE									
	70 F 21 C	80 F 27 C	90 F 32 C	100 F 38 C	110 F 43 C	120 F 49 C	130 F 54 C	140 F 60 C	150 F 66 C	160 F 71 C
85 F 29 C	n/a	n/a	n/a	n/a	OK					OK
80 F 26 C	n/a	n/a	n/a	n/a						OK
70 F 21 C	n/a	n/a	n/a	OK						OK
60 F 15 C	n/a	n/a	OK							OK
50 F 10 C	n/a	OK								OK
45 F 7 C	n/a									OK
40 F 4 C	OK									OK
35 F 2 C	OK									OK
30 F -1 C	OK							OK	n/a	n/a
25 F -4 C	OK						OK	n/a	n/a	n/a
20 F -7 C	OK					OK	n/a	n/a	n/a	n/a

Table 1, TGZ Temperature Limits, I.P. Units of Measure

COOLING CYCLE	MIN. TEMP.	MAX. TEMP.	NOTES:
Evaporator Leaving Water Temp.	40°F	60°F	In Cooling Cycle controlling Evap LWT - The Maximum Setpoint temp is 60°F
Condenser Leaving Water Temp	70°F	160° F	With Evap LWT above 50°F, the Cond LWT must be 30degrees F above Evap. LWT
Evaporator Water Delta-T	6°F	16°F	
With Glycol in Evap - Evap LWT	15°F	60°F	With Evap LWT below 40°F, the Cond EWT must not exceed 120 degrees F above the Evap LWT. Example: Evap LWT = 20°F Cond LWT must not exceed 140°F

Heating Cycle			
Evaporator Leaving Water Temp	40°F	85°F	With Evap LWT above 70°F, the Cond LWT must be 30 degrees F above Evap LWT
Condenser Leaving Water Temp	110°F	160°F	
Evaporator Water Delta-T	6°F	16°F	
Condenser Water Delta - T	Min.	Max	
with 2 Pass Condenser	10°F	15°F	Cond Water Delta-T should be 10 degrees F minimum for good condenser subcooling
with 4 Pass Condenser	15°F	40°F	

Table 2, TGZ Flow Limits, I.P. Units of Measure

UNIT NOMINAL TONS	40	50	60	80	100	110	120	150	170	190
Evaporator GPM Range										
10 F Water Temp Delta-T, 65° ELWT/130° CLWT	72	100	121	162	189	218	246	283	326	369
16-6 Water Temp Delta-T, 65° ELWT/130° LWT	45-120	62-167	75-202	101-270	118-315	136-363	154-410	177-472	204-543	231-615
10 Water Temp Delta-T, Full Unit Range	34-120	45-167	55-202	83-270	98-315	113-363	128-410	147-472	169-543	192-615
Condenser GPM Range - 4 Pass Condenser										
20 F Water Temp Delta-T, 65° ELWT/130° CLWT	47	64	77	103	120	138	156	180	207	234
40-15 F Water Temp Delta-T, 65° ELWT/130° CLWT	23-63	32-86	38-103	51-138	60-160	69-184	78-208	90-240	103-276	117-312
Condenser GPM Range - 2 Pass Condenser										
10 F Water Temp Delta-T, 65 ELWT/13° CLWT	94	128	154	206	240	276	312	360	414	468
15 F Water Temp Delta-T, 6° 5ELWT/130° CLWT	63	85	103	137	160	184	208	240	276	312

NOTE: ELWT=Evaporator Leaving Water Temperature, CLWT=Condenser Water Leaving Temperature.

Table 3, TGZ Temperature Limits, S.I. Units of Measure

COOLING CYCLE	MIN. TEMP.	MAX. TEMP.	NOTES:
Evaporator Leaving Water Temp.	4°C	15°C	In Cooling Cycle controlling Evap LWT - The Maximum Setpoint temp is 15°C
Condenser Leaving Water Temp	21°C	71°C	With Evap LWT above 10°C, the Cond LWT must be 17 degrees C above Evap. LWT
Evaporator Water Delta-T	-14°C	-9°C	
With Glycol in Evap - Evap LWT	-9°C	16°C	With Evap LWT below 4°C, the Cond EWT must not exceed 66 degrees C above the Evap LWT. Example: Evap LWT = -6°C Cond LWT must not exceed 60°C

Heating Cycle			
Evaporator Leaving Water Temp	4°C	29°C	With Evap LWT above 21°C, the Cond LWT must be 17 degrees C above Evap LWT
Condenser Leaving Water Temp	43°C	71°C	
Evaporator Water Delta-T	-9°C	16°C	
Condenser Water Delta - T	Min.	Max	
with 2 Pass Condenser	12°C	-9°C	Cond Water Delta-T should be 6 degrees C minimum for good condenser subcooling
with 4 Pass Condenser	-0°C	4°C	

Table 4, TGZ Flow Limits, S.I. Units of Measure

UNIT MODEL NO.	40	50	60	80	100	110	120	150	170	190
Evaporator l/s / Range										
5.5 F Water Temp Delta-T, 18° ELWT/54° CLWT	5	6	8	10	12	14	16	18	21	23
3-9 C Water Temp Delta-T, 18° ELWT/54° CLWT	3-8	4-11	5-13	6-17	7-20	9-23	10-26	11-30	13-34	15-39
5.5 C Water Temp Delta-T, Full Unit Range	2-8	3-11	3-13	5-17	6-20	7-23	8-26	9-30	11-34	12-39
Condenser l/s Range - 4 Pass Condenser										
11 C Water Temp Delta-T, 18° ELWT/54° CLWT	3	4	5	6	8	9	10	11	13	15
8-22 C Water Temp Delta-T, 18° ELWT/54° CLWT	1-4	2-5	2-6	3-9	4-10	4-12	5-13	6-15	6-17	7-20
Condenser l/s Range - 2 Pass Condenser										
5.5 C Water Temp Delta-T, 18° ELWT/54° CLWT	6	8	10	13	15	17	20	23	26	30
8 C Water Temp Delta-T, 18° ELWT/54° CLWT	4	5	6	7	10	12	13	15	17	20

NOTE: ELWT=Evaporator Leaving Water Temperature, CLWT=Condenser Water Leaving Temperature.

Waste Heat (Source Water) Side

Cooling Tower Water

Most commercial and institutional HVAC related Templifier applications use a chiller’s condenser outlet water for a heat source. Some points to remember:

- The condenser water from the air-conditioning system (waste heat source) is treated tower from an open system and proper tower water treatment and blowdown help to prevent fouling and possible clogging of the evaporator.
- Models TGZ 040 through 120 require an intermediate heat exchanger between the tower water and the Templifier evaporator.

- This heat-source water flows through the tube side of the evaporator of a centrifugal Templifier unit (Model TSC) and is subject to the same fouling (and attendant required maintenance) as a chiller condenser. A 20-mesh strainer is required at the evaporator inlet.
- TGZ Scroll Templifier units have brazed-plate, direct expansion evaporators on models 040 to 120 and shell-and-tube on models 150 to 190. A 40-mesh strainer is required on the entering fluid connection of brazed-plate evaporators (TGZ 040-120) and a 20-mesh strainer on shell-and-tube evaporators (TGZ 150-190).

⚠ CAUTION

Templifier Models TGZ 040 through TGZ 120 must have clean source water from a closed and treated loop to the brazed-plate evaporator. For open water loop applications, an intermediate heat exchanger between source water and evaporator is required. Failure to provide a clean, closed water loop can cause equipment failure and possible revocation of the unit warranty.

- A Templifier unit will often utilize only a portion of the entire tower water flow and require a bypass during normal operation. It is recommended that all installations have a tower water bypass around the Templifier unit's evaporator so that the chiller plant can remain operational in the event of Templifier evaporator servicing. (See Figure 1 on page 3.)

Cooling tower systems are usually designed with 95°F (35°C) entering to 85°F (29.4°C) leaving water temperatures. These temperatures will vary somewhat in areas with unusually high or low wet bulb temperatures. Air-conditioning chillers are then designed to operate in this environment as the worst or most severe condition. The cooling tower water temperature is allowed to drop as lower wet-bulb temperatures become available. This is good practice since chiller efficiency improves.

Important Note: These lower than design condenser water temperatures *must* be accounted for when selecting a Templifier unit. The Templifier unit must be selected to operate at the *lowest expected water temperature leaving the air-conditioning condenser during Templifier unit operation*. However, the COP used for economic evaluations should be based on a higher, weighted average source-water temperature.

Return Chilled Water

Using return chilled water as a heat source provides additional Templifier economic advantages.

First, as long as there is a heating load, the Templifier unit can produce chilled water and off-load the chilled water plant. The plant may be able to be reduced in size, depending on the ability of the Templifier unit to operate during periods of peak cooling load. A heat exchanger between the hot water loop and the cooling tower could provide a heat sink that is always available. The Templifier unit's heat rejection to the hot water loop is passed on to the cooling tower.

Second, additional energy is saved because the Templifier unit is now producing useful work in both the evaporator (chilling water) and in the condenser (heating water). An example helps clarify the point.

Take a Model TGZ 100 operating under the following two conditions:

- Heating water to 150°F with tower source water leaving the evaporator at 80°F.
- Evaporator heat=1018 MBH, Heating capacity=1341 MBH, 94.6 kW, Useful COP=4.15
- Heating water to 150°F with return chilled water leaving the TGZ evaporator at 50°F.
- Evaporator heat=600 MBH (50 tons cooling). Heating capacity=914 MBH, 92 kW,
- Useful COP=600 MBH + 914 MBH / 92 kW x 3413=COP 4.8
- Another way of putting it is a useful heating COP=2.91 plus 50 tons of free cooling.

The choice between using tower water as a heat source and using return chilled water is job dependent and should be analyzed for each project. A McQuay sales representative can analyze a specific project using the McQuay Energy Analyzer program, as described on page 5.

NOTE: Failure to provide a clean, closed water loop can cause equipment failure and possible revocation of the unit warranty. See product warranty for details.

Geothermal Warm Ground Water

Sufficient quantities of warm ground water are available in some locations to act as a heat source.

To maximize COP, use as high a quantity of ground water (to reduce Delta-T) as possible and consider the following:

- Flow capability of the evaporator.
- Quantity of water available and disposal considerations.
- Pump power

Ground water may contain:

- Particulate matter (sand, mud) that should be filtered out
- Corrosive elements that may require special evaporator materials or an intermediate heat exchanger
- High mineral content that can cause scaling. This will require a de-scaling maintenance program or an intermediate heat exchanger as shown in Figure 10.

Figure 10, Intermediate Heat Exchanger

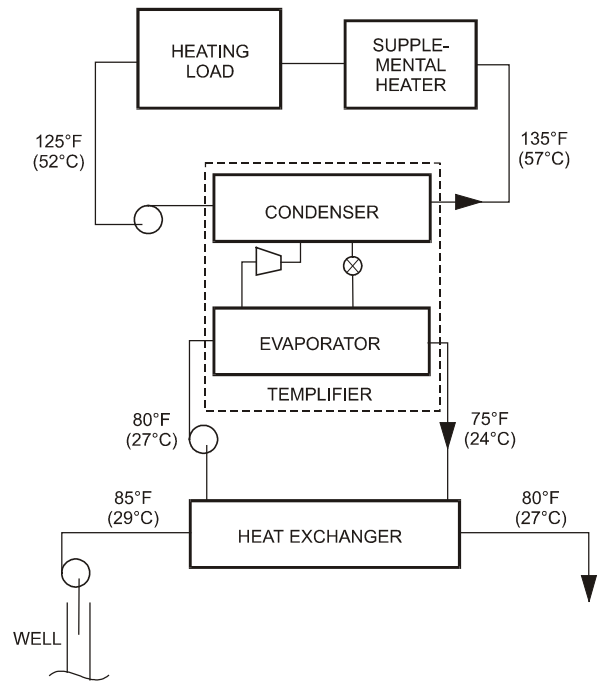

Solar Collectors

Templifier units can be mated with solar collector arrays and storage tanks to great advantage. The collectors do not have to be designed to provide the required use temperature. Instead, the collectors provide heat to the Templifier unit's evaporator and the Templifier amplifies the solar heat to the use temperature. This allows utilizing solar heat as low 50°F (10°C) to provide hot water output up to 136°F (58°C) for TSC units and 160°F (71°C) for TGZ units.

This temperature amplification reduces the number of expensive collectors required and/or allows more BTUs to be collected from an existing array.

Process Waste Water

Warm waste water from textile plants and pulp and paper plants is often contaminated with chemicals and particulate matter (gray water), requiring intermediate heat exchangers, perhaps tube-in-tube type that can handle high particulate concentrations.

Miscellaneous

There are many sources of waste heat in industry. Things to remember when considering their suitability to Templifier systems are the quality of the water, the temperature extremes possible and the availability of source heat.

Water Heating Side

General recommendations for the hot water side of the Templifier system include:

- The lowest possible hot water temperature should be selected in order to maximize the unit COP. Booster heaters should be employed for open systems such as laundry or dishwashing water that have temperature requirements higher than the Templifier unit's capability.
- Supplementary heaters are usually required in case the heat pump is unavailable or there is insufficient waste heat available.
- Temperature control strategy
- TSC Centrifugal Templifier units are controlled by the leaving hot water temperature. To reduce the chance of compressor stall, the hot water temperature is reset downwards based on a selectable leaving evaporator (source water) temperature.
- TGZ Scroll Templifier units are controlled by the leaving hot water temperature. Higher COPs and better unloading can be achieved when the entering water temperature is controlled. This is accomplished by resetting the leaving hot water setpoint downward based on the hot water Delta-T (assuming a constant hot water flow). This method is especially recommended for space heating where it essentially provides hot water reset based on heating load since the hot water temperature to the heating load decreases as the load decreases.

Service Hot Water

Service hot water systems will invariably use a storage tank due to the large variation in demand. Large buildings will use a recirculating hot water system that will provide instant hot water at the point of use. A Templifier unit can be used in the system as shown in Figure 11.

Temperature control should be on the leaving water temperature in order to maintain tank temperature. The tank temperature should be as low as possible, usually 120°F (49°C) for laundry tub, and shower use and 140°F (60°C) for kitchen use.

Supplementary/standby heat should be provided in case the Templifier unit is off-line or if there is insufficient source heat to maintain the setpoint temperature.

A Templifier unit used for both service water heating and space heating should employ an intermediate heat exchanger between the service water system and the unit.

Some local codes may require an additional heat transfer device (heat exchanger) between the refrigerant and potable water

Figure 11, Service Hot Water

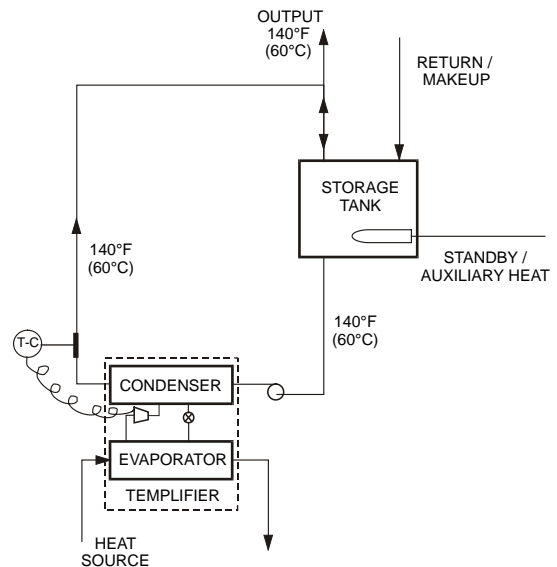

Outside Air Heating

Templifier units are well suited to heating outside air because of the relatively low air temperature requirements. It is imperative that precautions be taken to prevent freezing the coil. Even though mixed air temperatures can be above freezing or even at setpoint shutting off water flow, cold air can stratify at the bottom of the heating coil and freeze the coil.

Figure 12 illustrates a method of using a continuously running small circulating pump and three-way valve (two-way valve can also be used) to provide full water flow to the coil at all times. The flow switch overrides normal control and throws the control valve to full open preventing freeze-up. Overheating of the air will result. Power failure or operator error can defeat this protective arrangement.

Figure 12, Outside Air Heating

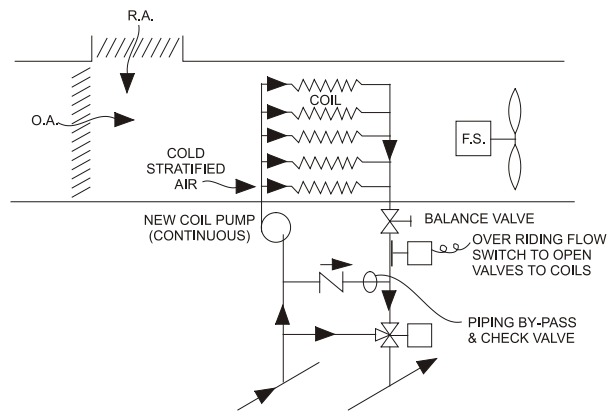

Water-Loop Heat Pump Systems

Unitary water-source heat pumps (WSHP) in closed water loops have proven to be a flexible and efficient system for many buildings, especially offices, schools, health care facilities and hotels. These systems should be balanced in regard to the disposition of heat, i.e. not throwing away any heat that can be recovered and used somewhere, somehow in the building. Furthermore, when there is truly excess heat, thought should be given to storing it for later use. Typically, excess heat can be generated during the day and used at night when the net building load requires heat input to the loop.

The Templifier unit can be used to advantage in WSHP systems by recovering low grade heat that would otherwise be rejected and increasing its temperature to a useful level. This high grade heat can be:

- Stored up to 136°F (58°C) for TSC units and 160°F (71°C) for TGZ units during periods of excess heat, usually daytime hours, and then used as a heat source when heat input into the system is required, usually at night. A conventional storage tank (without a Templifier unit) in the main loop has to be excessively large since it is limited to the min/max loop temperature, usually 60°F to 90°F (15°C to 32°C).
- Used instantaneously for other building heating loads such as domestic hot water, reheat, and make-up air heating.

Figure 13 illustrates how to place the Templifier Heat Pump in the WSHP system. Controls are usually set so that:

- The water heater comes on to control a minimum of 60°F (15°C) loop temperature.
- The heat rejection device comes on to control a maximum of 90°F (32°C) loop temperature.
- The Templifier unit will cycle and load in response to its heating load but also have an evaporator leaving water temperature override to prevent cooling the loop below 63°F (17°C). This eliminates the possibility of the Templifier unit's cooling the loop below the minimum loop temperature and energizing the system heater.

Figure 13, Water Source Heat Pump System

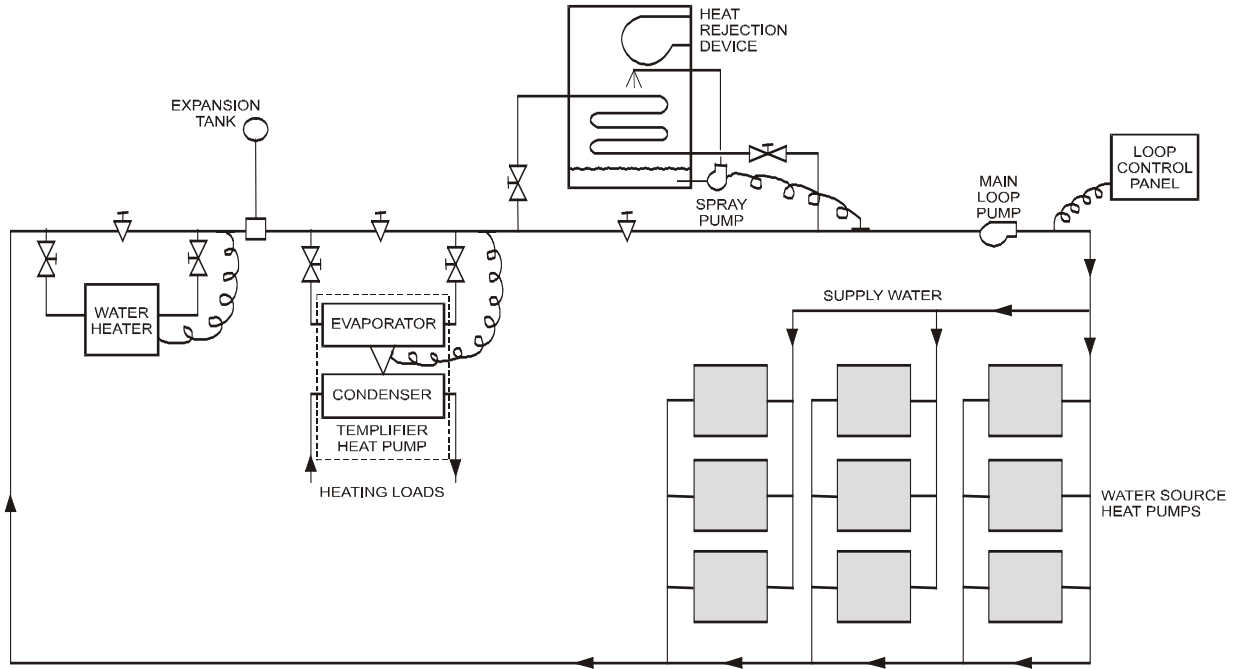

Environmental Impact

The environmental impact of any process or equipment is vitally important today and will continue to be in the future. Templifier Heat Pump Water Heaters have some distinct advantages when it comes to their effect on our environment. Environmental impact is measured in several ways:

- **ODP-Ozone Depletion Potential**; measures the impact of a substance on the depletion of the ozone layer in the upper atmosphere. With refrigerants, this action is caused by chlorine. HFC-134a contains no chlorine and has a zero ODP.
- **GWP-Global Warming Potential**; measures the contribution of a substance to the greenhouse gas effect which causes global warming. This is a pound to pound comparison, discounting the application of the substance and any other effects caused by its use. The number, relative to CO₂ for a 100 year integration time horizon is HFC-134a=1300.
- **TEWI-Total Equivalent Warming Impact**; is a combination of the refrigerant GWP, unit refrigerant emissions rate, and the refrigeration system's energy efficiency. Science has agreed that a systems approach is necessary to evaluate the *real* effect of a substance on global warming. This is TEWI. In a Templifier unit, the contribution of the refrigerant GWP is insignificant when compared to the effect of a unit's power needs translated to power plant CO₂ emissions.

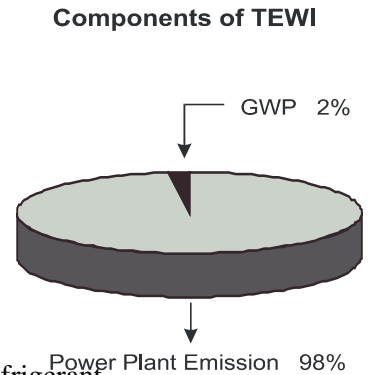

The percentages shown below will vary slightly depending on unit refrigerant loss and on the efficiency of local power generation. Equipment operators should keep equipment leak free (minimize the 2% segment) and operate as efficiently as possible (minimize the 98% segment).

The significant influence in establishing the TEWI of a hot water plant is the system used to produce the heat, as illustrated in the following examples. Compare the fuel burned (products of combustion) to produce one million BTUs of hot water at 120°F.

Figure 14, Comparative Fuel Use

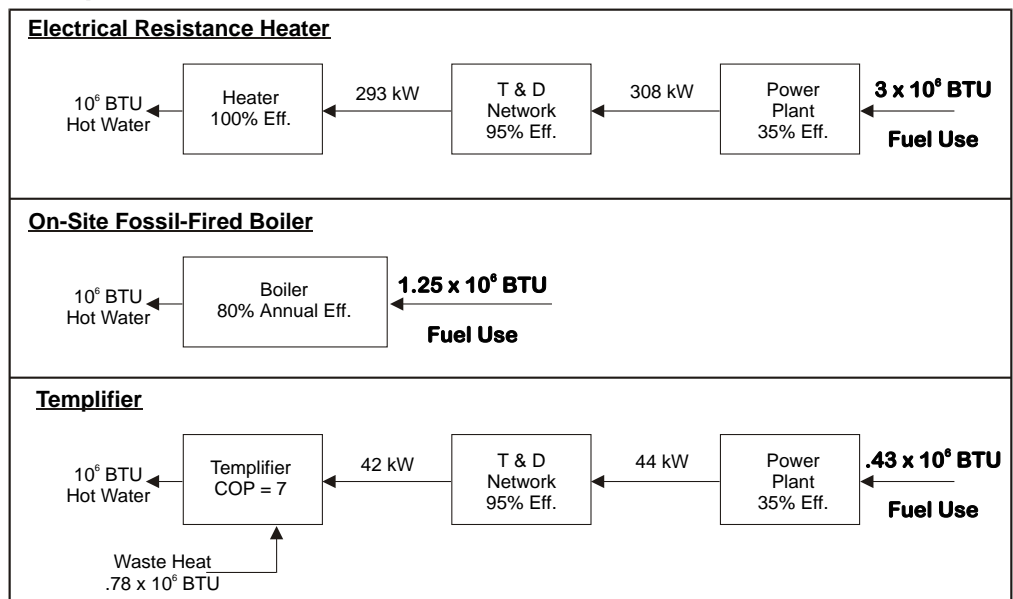

Compared to a Templifier unit, a resistance heater burns seven times the fuel quantity and an on-site boiler consumes three times the amount. The Templifier provides an advantage for buildings designed for LEED® certification.

LEED

Energy recovery systems such as a Templifier system can contribute points to the Energy and Atmosphere section of the LEED rating system. Energy performance above the minimum level efficiency, as determined by ASHRAE 90.1-2004, can earn up to 10 points. Energy recovery systems reduce fossil fuel consumption and lower the cost of heating, thus contributing to the reduction in a building's carbon footprint.

Templifier units, which use R-134a, also qualify for a point under the Enhanced Refrigerant Management Credit of the LEED rating system.

Carbon Footprint

Carbon footprint is a measure of the amount of carbon released to the atmosphere and should be minimized. A Templifier unit usually off-loads a fossil fired boiler with electrical energy. Total carbon reduction then becomes a matter of whether the generating plant is fired by fossil fuels or by non-polluting energy such as hydro or nuclear power. The reduction is not as great if fossil fuels are used.

ASHRAE 90.1

ASHRAE 90.1 allows simultaneous heating and cooling if at least 75% of the reheat energy is provided by a site recovered energy source.

It is also important to note that condenser heat recovery is required for domestic hot water systems if they operate 24 hours per day, have a cooling load of at least 400 tons and a domestic hot water load of at least one million Btu/hr. A Templifier unit recovering waste heat going to a cooling tower and generating hot water for reheat meets both of these requirements. With boilers having a COP of less than 1 and Templifier unit's having a COP of close to 4, it can be an attractive way to comply with ASHRAE 90.1.

Since reheat water is generally at a relatively low temperature, very attractive COPs result.

Selection Procedure

TGZ Scroll

Capacity ratings for Model TGZ Templifiers are found in Table 7 and Table 8 for Inch-Pound (I-P) units and in Table 9 and Table 10 for System International (SI) units. The ratings are based on leaving source water (evaporator) temperature and leaving hot water (condenser) temperature.

The ratings are based on a 10 degree F evaporator Delta-T, a 20 degree F condenser Delta-T and the standard four-pass condenser arrangement.

There is no correction for other evaporator Delta-Ts. Table 5 has corrections for condenser Delta-Ts other than 20 degrees. Table 6 contains corrections for non-standard fouling factors.

In many cases it will be necessary to manipulate flow, entering and leaving temperatures, and delta-T values to arrive at the conditions given in the tables. For example, source water temperature is often noted as the *entering* temperature and must be converted to *leaving* temperature. Use the following formulae:

$$\text{Heat Output/Heat Input}=\text{COP}$$

$$\text{GPM} \times \text{Delta T } ^\circ\text{F} \times 500=\text{BTU/Hr} \qquad \text{L/S} \times \text{Delta-T } ^\circ\text{C}=0.24 \text{ kW}$$

$$\text{kW} \times 3413=\text{BTU/Hr}$$

$$\text{Evaporator Heat In} + \text{Power kW}=\text{Condenser Heat Out}$$

Sample Selection

Select a Templifier unit to produce 1,000 MBH of hot water, heating 200 gpm of water to 140°F. Source water is available from a 1,000 ton air-conditioning system's condenser water going to the cooling tower and varies from 95°F to 70°F.

Thought should be given as to whether the Templifier unit must produce full capacity throughout the entire source water temperature range or whether it is acceptable to produce less heat as the source water temperature drops. The second strategy can benefit from a smaller unit size and more full-load operation.

In this sample selection it is assumed that the Templifier unit must produce design heating capacity throughout the entire source water temperature range. That is, 1,000 MBH heating output with entering source water as low as 70°F.

A 1,000 ton chiller system will have a nominal flow of 3,000 gpm of condenser water, well in excess of the Templifier unit's needs. With excessive source water flow available, it is prudent to use a high flow rate, sufficient to yield a 5-degree range (permissible in the heating mode only) in the Templifier evaporator, giving a 65°F leaving temperature. This will maximize the COP.

There are several ways to arrive at the required source water flow. One is as follows:

1. With the heating capacity and the source and hot water leaving temperatures known, a unit can be selected from the Table 8, Heating/Cooling Performance (IP), 60 Hz, 140°F to 160°F

Select a Model TGZ 080 with the following performance:

Heating capacity of 1006 MBH - COP of 4.08

Cooling capacity of 759 MBH - 72.3 kW

2. Correct the heating and cooling capacities, COP and kW, for condenser Delta-T from Table 5 on page 27. This example has a 20 degree condenser Delta-T and a correction factor of one, so no correction is required.

- Calculate the source water flow with cooling (evaporator) capacity of 759MBH,

$$GPM \times \Delta T \times 500/1000 = \text{Evap MBH}$$

$$GPM = (759 \times 1000) / (5 \text{ deg} \times 500) = 303 \text{ gpm}$$
- The COP of 4.08 is the worst case anticipated (highest lift). For economic evaluations an average COP should be used. Using a COP of 5.81 at 90°F leaving (extrapolated from Table 8) and the COP of 4.08 at 65°F leaving, calculate an average COP of 4.9 at 77.5°F.

50-Hertz Selections

For 50-hertz applications, multiply the capacity in the 60-hertz performance tables by 0.83 and the power by 0.81. Units are available at 400 volts for 50-hertz power.

Delta-T Effect on Operation

Unit controller control band for staging logic and TGZ leaving water temperature operating range around the setpoint:

- For 4 compressor unit - control band is 0.3 times the condenser water temperature Delta -T at 100% unit load
- For 6 compressor unit - control band is 0.2 times the condenser water temperature Delta -T. at 100% unit load

Note: The control band is divided by 2 for the amount of temperature above and below the target setpoint.

Example:

Control band for a 4-compressor unit with 20-degree F condenser water temperature Delta-T = 0.3 times the Delta-T of 20

Control Band will be 0.3 times 20 = 6 F

Band Range above and below target setpoint = 6/2 = 3 F

For a target leaving condenser water setpoint = 130°F, and a total control band = 6 degrees F, the unit will stage up when condenser water temperature is lower than 130.0 F minus 3 F = 127.0 F, and will stage down when the condenser water temperature is higher than 130.0 F plus 3 F = 133.0 F

Note: The same formula is used for evaporator control band calculation if in the cooling mode.

TSC Centrifugal

Due to the large number of centrifugal component combinations available, units are selected on a computer program. Consult the local McQuay sales office for unit performance. The following parameters are required:

Heating Mode

Source Heat: flow available, minimum and maximum temperature to the evaporator, fouling factor

Hot Water: flow available, minimum and maximum temperature to the condenser, fouling factor

Electrical characteristics

Cooling Mode

Chilled water: flow, temperature in and out, capacity required, fouling factor

Tower water (or other heat sink): flow, temperature in and out, capacity required, fouling factor

Electrical characteristics

TGZ Capacity Adjustment Factors

Table 5, Condenser Water Temperature Range Correction Factor

CONDENSER WATER DELTA-T		UNIT PERFORMANCE MULTIPLIER		CONDENSER PASSES
DEG. F	DEG. C	HEATING CAPACITY	COP	
6.0	3.3	0.92	0.92	Not recommended due to low liquid subcooling
10.0	5.5	0.95	0.95	2 Pass Condenser
15.0	8.3	0.98	0.98	2 or 4 Pass Condenser
20.0	11.0	1.00	1.00	4 Pass Condenser
25.0	13.8	1.02	1.02	4 Pass Condenser
30.0	16.5	1.05	1.05	4 Pass Condenser
35.0	19.3	1.07	1.07	4 Pass Condenser
40.0	22.0	1.09	1.09	4 Pass Condenser

NOTE: Evaporator water temperature range has a negligible effect on unit performance over the acceptable range of 5 to 20 degrees F (3 to 11 degrees C).

Table 6, Fouling Factor Correction

FOULING FACTOR		CONDENSER		EVAPORATOR	
FT ² HR °F/BTU	M ² °C/KW	CAPACITY	COP, KW	CAPACITY	COP, KW
0.00025	0.044	1.00	1.00	0.993	0.998
0.00075	0.132	0.98	1.038	Not Recommended	

Performance Data

TGZ Scroll

Table 7, Heating/Cooling Performance (IP), 60 Hz, 110°F to 130°F

TGZ UNIT SIZE	LEAVING SOURCE TEMP (°F)	LEAVING HOT WATER TEMPERATURE											
		110°F				120°F				130°F			
		EVAP CAP (MBH)	UNIT KW	HEAT CAP (MBH)	COP	EVAP CAP (MBH)	UNIT KW	HEAT CAP (MBH)	COP	EVAP CAP (MBH)	UNIT KW	HEAT CAP (MBH)	COP
40	45	272	25.2	358	4.17	253	28.2	349	3.63	233	31.6	341	3.17
	55	338	25.6	425	4.86	316	28.6	413	4.23	292	32.0	402	3.68
	65	413	25.8	501	5.69	387	28.7	485	4.95	360	32.1	470	4.29
	75	498	25.6	586	6.70	469	28.4	565	5.84	437	31.6	545	5.06
	85	593	24.9	678	7.99	559	27.5	653	6.97	524	30.5	628	6.03
50	45	384	31.8	492	4.53	359	35.6	480	3.96	331	39.9	468	3.43
	55	467	32.4	578	5.23	441	36.0	564	4.59	406	40.2	543	3.96
	65	465	34.7	584	4.93	523	36.7	649	5.18	500	40.7	639	4.59
	75	654	34.7	773	6.52	631	37.9	761	5.88	597	41.7	739	5.19
	85	778	37.0	904	7.17	742	39.8	877	6.46	703	43.3	851	5.75
60	45	464	38.0	593	4.58	435	42.3	579	4.01	402	47.3	563	3.49
	55	565	38.7	697	5.28	533	42.9	679	4.64	497	47.8	661	4.05
	65	677	39.8	813	5.99	643	43.8	792	5.30	605	48.5	770	4.65
	75	803	41.3	943	6.70	765	45.2	919	5.96	724	49.7	893	5.27
	85	941	43.4	1089	7.36	900	47.1	1061	6.60	855	51.4	1031	5.88
80	45	591	50.4	763	4.44	557	56.3	749	3.90	522	62.9	737	3.43
	55	736	51.3	911	5.21	695	57.2	890	4.56	654	63.8	871	4.00
	65	907	52.3	1086	6.08	858	58.2	1057	5.33	809	64.8	1030	4.66
	75	1107	53.7	1290	7.05	1050	59.4	1253	6.18	992	66.0	1217	5.41
	85	1339	55.4	1528	8.09	1273	61.0	1481	7.11	1205	67.5	1436	6.23
100	45	693	58.7	893	4.46	654	65.0	876	3.95	615	72.2	861	3.49
	55	861	59.8	1065	5.22	814	66.6	1041	4.58	773	73.9	1025	4.07
	65	1059	60.1	1264	6.17	1002	67.7	1233	5.34	945	75.4	1202	4.67
	75	1290	58.9	1491	7.42	1223	67.8	1454	6.29	1155	76.3	1415	5.44
	85	1559	55.9	1749	9.17	1479	66.4	1706	7.53	1400	76.1	1660	6.39
110	45	773	66.9	1015	4.23	753	74.1	1006	3.98	708	82.3	989	3.52
	55	992	68.2	1224	5.26	937	75.9	1196	4.61	885	84.2	1173	4.08
	65	1220	68.4	1453	6.22	1154	77.2	1417	5.38	1088	85.9	1381	4.71
	75	1483	67.5	1714	7.44	1408	77.2	1672	6.34	1330	86.9	1627	5.48
	85	1795	63.7	2012	9.25	1704	75.7	1962	7.59	1612	86.7	1908	6.44
120	45	852	75.0	1136	4.00	852	83.1	1136	4.00	801	92.4	1116	3.54
	55	1122	76.5	1383	5.30	1060	85.2	1351	4.65	998	94.5	1320	4.09
	65	1380	76.8	1642	6.27	1306	86.6	1601	5.42	1231	96.4	1560	4.74
	75	1676	76.0	1936	7.46	1593	86.7	1889	6.39	1505	97.6	1838	5.52
	85	2031	71.5	2275	9.33	1928	84.9	2218	7.65	1825	97.3	2157	6.49
150	45	1040	88.0	1340	4.46	981	97.5	1314	3.95	922	108.3	1292	3.49
	55	1292	89.8	1598	5.22	1220	100.0	1561	4.58	1160	110.9	1538	4.07
	65	1589	90.1	1896	6.17	1503	101.6	1850	5.34	1417	113.1	1803	4.67
	75	1936	88.3	2237	7.42	1834	101.7	2181	6.29	1733	114.5	2123	5.44
	85	2338	83.8	2624	9.17	2219	99.6	2559	7.53	2100	114.2	2490	6.39
170	45	1197	100.3	1539	4.50	1130	111.1	1509	3.98	1062	123.4	1483	3.52
	55	1487	102.3	1836	5.26	1405	113.9	1794	4.62	1328	126.3	1759	4.08
	65	1829	102.6	2180	6.22	1731	115.7	2126	5.38	1632	128.9	2072	4.71
	75	2225	101.2	2570	7.45	2112	115.8	2507	6.34	1995	130.4	2440	5.48
	85	2692	95.5	3018	9.26	2555	113.5	2943	7.60	2419	130.1	2862	6.45
190	45	1355	112.5	1739	4.53	1278	124.7	1704	4.00	1201	138.5	1674	3.54
	55	1683	114.8	2075	5.30	1590	127.8	2026	4.65	1497	141.8	1980	4.09
	65	2070	115.2	2463	6.27	1958	129.9	2402	5.42	1846	144.7	2340	4.74
	75	2514	114.0	2903	7.46	2390	130.0	2834	6.39	2258	146.4	2757	5.52
	85	3047	107.2	3412	9.33	2892	127.4	3326	7.65	2737	146.0	3235	6.49

Continued next page.

Table 8, Heating/Cooling Performance (IP), 60 Hz, 140°F to 160°F

TGZ UNIT SIZE	LEAVING SOURCE TEMP. (°F)	LEAVING HOT WATER TEMPERATURE											
		140°F				150°F				160°F			
		EVAP CAP (MBH)	KW	HEAT CAP (MBH)	COP	EVAP CAP (MBH)	KW	HEAT CAP (MBH)	COP	EVAP CAP (MBH)	KW	HEAT CAP (MBH)	COP
40	45	213	35.3	333	2.77	192	39.3	326	2.43	170	43.6	319	2.14
	55	268	35.7	390	3.20	243	39.8	379	2.79	217	44.2	368	2.44
	65	332	35.8	454	3.72	303	39.8	439	3.23	273	44.3	424	2.80
	75	405	35.2	525	4.37	371	39.3	505	3.77	336	43.7	486	3.25
	85	487	34.0	603	5.19	449	38.0	578	4.46	409	42.4	553	3.83
50	45	296	44.9	449	2.94	267	50.5	439	2.55	229	56.8	423	2.18
	55	380	45.1	533	3.47	344	50.7	517	2.99	306	57.0	500	2.57
	65	465	45.5	621	4.00	428	51.0	602	3.46	382	57.3	577	2.95
	75	559	46.3	717	4.54	512	51.7	688	3.90	476	57.9	674	3.41
	85	652	47.7	815	5.01	619	52.8	799	4.43	572	58.9	773	3.85
60	45	365	53.0	546	3.02	323	59.5	526	2.59	276	66.7	503	2.21
	55	458	53.3	640	3.52	413	59.6	617	3.03	364	66.7	591	2.60
	65	562	53.9	746	4.05	515	60.0	720	3.51	462	66.9	690	3.02
	75	678	54.9	865	4.62	627	60.8	835	4.02	572	67.5	802	3.48
	85	806	56.4	999	5.19	752	62.0	964	4.55	693	68.5	927	3.97
80	45	487	70.3	727	3.03	452	78.5	720	2.69	417	87.5	715	2.40
	55	612	71.3	855	3.52	569	79.5	840	3.10	526	88.7	829	2.74
	65	759	72.3	1006	4.08	709	80.6	984	3.58	658	89.9	964	3.14
	75	933	73.5	1184	4.72	874	81.8	1153	4.13	814	91.2	1125	3.62
	85	1137	74.9	1393	5.45	1068	83.3	1352	4.76	998	92.6	1314	4.16
100	45	574	80.9	851	3.08	533	91.7	846	2.70	490	105.1	849	2.37
	55	717	82.3	998	3.56	668	92.2	982	3.12	617	104.4	973	2.73
	65	887	83.8	1173	4.10	828	93.3	1146	3.60	768	104.7	1125	3.15
	75	1087	85.0	1377	4.75	1018	94.6	1341	4.15	948	105.5	1308	3.63
	85	1321	85.6	1613	5.52	1240	95.5	1566	4.81	1159	106.4	1522	4.19
110	45	661	92.2	976	3.10	614	104.5	970	2.72	565	119.8	973	2.38
	55	826	93.7	1145	3.58	769	105.1	1127	3.14	710	119.0	1116	2.75
	65	1021	95.4	1347	4.13	953	106.3	1316	3.62	884	119.3	1291	3.17
	75	1252	96.9	1582	4.78	1172	107.8	1540	4.18	1091	120.2	1501	3.66
	85	1521	97.6	1854	5.56	1428	108.8	1800	4.84	1335	121.2	1748	4.22
120	45	748	103.5	1102	3.12	695	117.2	1095	2.74	639	134.4	1097	2.39
	55	934	105.2	1293	3.60	870	117.9	1272	3.16	804	133.5	1259	2.76
	65	1156	107.1	1521	4.16	1079	119.3	1486	3.65	1001	133.9	1458	3.19
	75	1416	108.7	1787	4.82	1326	120.9	1739	4.21	1235	134.9	1695	3.68
	85	1721	109.5	2094	5.61	1616	122.2	2033	4.88	1510	136.0	1974	4.25
150	45	862	121.4	1276	3.08	800	137.5	1269	2.70	735	157.7	1273	2.37
	55	1076	123.4	1497	3.56	1001	138.3	1473	3.12	925	156.7	1459	2.73
	65	1330	125.7	1759	4.10	1242	140.0	1720	3.60	1152	157.1	1688	3.15
	75	1630	127.6	2065	4.75	1527	141.9	2011	4.15	1421	158.3	1961	3.63
	85	1981	128.5	2419	5.52	1860	143.3	2349	4.81	1739	159.6	2283	4.19
170	45	992	138.3	1464	3.10	921	156.7	1455	2.72	847	179.6	1460	2.38
	55	1239	140.6	1718	3.58	1153	157.6	1691	3.14	1065	178.5	1674	2.75
	65	1532	143.2	2020	4.14	1430	159.5	1974	3.63	1326	179.0	1937	3.17
	75	1877	145.3	2373	4.79	1758	161.6	2310	4.19	1637	180.3	2252	3.66
	85	2281	146.4	2780	5.57	2142	163.3	2700	4.85	2002	181.8	2622	4.23
190	45	1123	155.2	1652	3.12	1042	175.9	1642	2.74	958	201.6	1646	2.39
	55	1402	157.8	1940	3.60	1305	176.9	1908	3.16	1205	200.3	1889	2.76
	65	1733	160.7	2282	4.16	1618	179.0	2229	3.65	1501	200.8	2186	3.19
	75	2124	163.1	2681	4.82	1989	181.4	2608	4.21	1852	202.4	2543	3.68
	85	2581	164.2	3142	5.61	2424	183.2	3050	4.88	2265	204.1	2961	4.25

NOTE: Performance is based on 4-pass condenser, 10-degree F evaporator delta-T, and 20-degree F condenser delta-T. See page 25 for selection information.

Table 9, Heating/Cooling Performance (SI) 60 Hz, 45°C to 55°C

TGZ UNIT SIZE	LEAVING SOURCE TEMP (°C)	LEAVING HOT WATER TEMPERATURE											
		45°C				50°C				55°C			
		EVAP CAP (KW)	KW INPUT	HEAT CAP (KW)	COP	EVAP CAP (KW)	KW INPUT	HEAT CAP (KW)	COP	EVAP CAP (KW)	KW INPUT	HEAT CAP (KW)	COP
040	7.0	77	26.1	103	3.98	72	28.9	101	3.52	67	32.0	99	3.10
	13.0	98	26.5	124	4.70	92	29.3	121	4.15	86	32.4	118	3.65
	18.0	117	26.7	144	5.41	111	29.4	140	4.77	104	32.5	136	4.19
	24.0	144	26.4	170	6.46	136	29.0	165	5.70	128	32.0	160	5.00
	30.0	174	25.6	199	7.82	165	28.0	193	6.90	155	30.8	186	6.04
050	7.0	109	33.0	142	4.33	103	36.4	139	3.83	95	40.4	136	3.36
	13.0	135	33.5	168	5.04	128	36.8	165	4.49	119	40.7	160	3.93
	18.0	139	35.3	174	4.93	150	37.4	188	5.03	144	41.2	185	4.50
	24.0	190	35.7	226	6.34	184	38.7	222	5.75	174	42.3	216	5.13
	30.0	229	38.1	267	7.03	219	40.7	259	6.38	208	44.0	252	5.73
060	7.0	132	39.3	409	2.15	124	43.3	168	3.88	116	47.9	163	3.42
	13.0	164	40.0	447	2.41	155	43.9	199	4.54	146	48.4	194	4.01
	18.0	194	40.9	497	2.45	184	44.7	229	5.13	174	49.1	223	4.55
	24.0	233	42.5	275	6.49	222	46.1	269	5.83	211	50.3	262	5.21
	30.0	277	44.7	321	7.20	265	48.1	314	6.53	253	52.1	305	5.87
080	7.0	169	52.2	221	4.25	160	57.6	217	3.78	151	63.7	214	3.37
	13.0	214	53.1	267	5.04	203	58.5	262	4.48	192	64.6	257	3.97
	18.0	258	54.0	312	5.80	246	59.4	305	5.15	233	65.5	298	4.56
	24.0	321	55.4	376	6.80	306	60.8	366	6.04	290	66.8	357	5.35
	30.0	394	57.3	451	7.90	376	62.5	439	7.04	358	68.5	426	6.24
100	7.0	198	60.6	258	4.28	188	66.4	254	3.84	177	73.1	250	3.43
	13.0	250	61.9	312	5.06	238	68.1	306	4.50	227	74.9	302	4.03
	18.0	302	62.4	364	5.85	287	69.3	356	5.15	272	76.3	348	4.57
	24.0	374	61.5	435	7.11	356	69.5	425	6.14	338	77.2	415	5.38
	30.0	458	58.8	517	8.85	437	68.2	505	7.43	416	77.1	493	6.40
110	7.0	223	69.0	294	4.26	217	75.7	292	3.86	204	83.3	287	3.45
	13.0	288	70.6	359	5.09	274	77.6	352	4.54	260	85.3	346	4.06
	18.0	348	71.1	419	5.89	331	78.9	409	5.18	313	86.9	400	4.60
	24.0	430	70.4	500	7.10	410	79.2	489	6.17	389	88.0	477	5.42
	30.0	528	67.0	595	8.88	504	77.7	581	7.48	479	87.9	567	6.45
120	7.0	247	77.4	330	3.97	245	84.9	330	3.89	231	93.5	324	3.48
	13.0	326	79.2	405	5.13	310	87.1	397	4.56	293	95.7	389	4.06
	18.0	393	79.8	473	5.95	374	88.5	462	5.23	354	97.5	452	4.64
	24.0	486	79.2	565	7.17	464	88.8	552	6.24	440	98.8	539	5.46
	30.0	597	75.1	672	9.01	570	87.2	657	7.55	542	98.6	640	6.50
150	7.0	297	90.8	388	4.28	282	99.6	381	3.84	266	109.7	375	3.43
	13.0	375	92.9	468	5.06	357	102.2	459	4.50	340	112.3	452	4.03
	18.0	453	93.6	546	5.85	430	103.9	534	5.15	408	114.4	522	4.57
	24.0	560	92.3	653	7.11	534	104.2	638	6.14	506	115.9	622	5.38
	30.0	687	88.2	776	8.85	656	102.3	758	7.43	623	115.7	739	6.40
170	7.0	342	103.5	445	4.32	324	113.5	438	3.87	306	124.9	431	3.46
	13.0	432	105.8	538	5.10	411	116.5	527	4.54	390	127.9	518	4.05
	18.0	521	106.7	628	5.91	495	118.3	614	5.20	469	130.3	600	4.61
	24.0	645	105.5	750	7.14	614	118.7	733	6.19	583	132.0	715	5.43
	30.0	792	100.5	892	8.94	755	116.6	872	7.50	718	131.8	850	6.46
190	7.0	387	116.1	376	3.97	367	127.3	494	3.89	347	140.2	487	3.48
	13.0	489	118.8	608	5.13	464	130.7	595	4.56	439	143.6	583	4.06
	18.0	590	119.7	710	5.95	561	132.8	694	5.23	531	146.3	677	4.64
	24.0	729	118.8	847	7.17	695	133.2	829	6.24	660	148.1	808	5.46
	30.0	896	112.7	1009	9.01	854	130.8	985	7.55	812	147.9	960	6.50

Continued next page.

Table 10, Heating/Cooling Performance (SI), 60 Hz, 60°C to 70°C

TGZ UNIT SIZE	LEAVING SOURCE TEMP (°C)	LEAVING HOT WATER TEMPERATURE											
		60°C				65°C				70°C			
		EVAP CAP (KW)	KW INPUT	HEAT CAP (KW))	COP	EVAP CAP (KW)	KW INPUT	HEAT CAP (KW)	COP	EVAP CAP (KW)	KW INPUT	HEAT CAP (KW)	COP
040	7.0	62	35.3	97	2.75	56	38.9	95	2.45	51	42.7	93	2.19
	13.0	79	35.7	115	3.22	73	39.4	112	2.85	66	43.3	109	2.52
	18.0	96	35.8	132	3.69	89	39.4	128	3.25	81	43.4	124	2.86
	24.0	119	35.2	154	4.38	110	38.8	149	3.85	101	42.8	144	3.37
	30.0	145	33.9	179	5.28	135	37.4	173	4.62	124	41.4	166	4.02
050	7.0	86	44.8	131	2.92	78	49.9	128	2.58	69	55.5	124	2.24
	13.0	112	45.1	157	3.49	103	50.1	153	3.06	93	55.7	148	2.67
	18.0	135	45.5	180	3.97	125	50.4	176	3.49	113	56.0	169	3.03
	24.0	164	46.3	211	4.55	152	51.1	203	3.98	142	56.6	199	3.52
	30.0	194	47.8	242	5.06	186	52.4	238	4.55	174	57.8	231	4.02
060	7.0	106	53.0	159	3.00	95	58.8	154	2.62	83	65.3	148	2.27
	13.0	135	53.4	189	3.54	124	59.0	183	3.10	111	65.3	176	2.70
	18.0	163	53.9	217	4.02	151	59.3	210	3.54	137	65.5	202	3.10
	24.0	199	54.9	254	4.63	186	60.2	246	4.10	171	66.2	238	3.60
	30.0	240	56.5	297	5.26	226	61.6	288	4.68	211	67.3	278	4.14
080	7.0	142	70.2	212	3.02	132	77.5	210	2.71	123	85.6	209	2.44
	13.0	181	71.3	252	3.54	170	78.7	248	3.16	158	86.9	245	2.83
	18.0	220	72.2	292	4.04	207	79.7	286	3.60	193	88.0	281	3.20
	24.0	275	73.5	348	4.74	259	81.0	340	4.20	243	89.3	332	3.73
	30.0	340	75.1	415	5.53	321	82.5	404	4.90	302	90.9	393	4.34
100	7.0	167	80.9	248	3.06	156	90.5	247	2.73	145	102.4	247	2.42
	13.0	212	82.3	294	3.58	199	91.2	290	3.19	185	102.0	287	2.82
	18.0	257	83.7	340	4.07	242	92.2	334	3.62	226	102.4	328	3.21
	24.0	320	85.1	405	4.76	302	93.6	395	4.23	283	103.4	386	3.75
	30.0	395	85.7	480	5.60	373	94.6	468	4.95	351	104.3	456	4.38
110	7.0	192	92.2	285	3.09	180	103.1	283	2.75	167	116.7	284	2.43
	13.0	244	93.8	338	3.60	229	103.9	333	3.21	214	116.2	330	2.84
	18.0	296	95.4	391	4.10	279	105.1	384	3.65	260	116.7	377	3.23
	24.0	369	97.0	465	4.79	348	106.7	454	4.25	326	117.8	444	3.77
	30.0	455	97.7	552	5.65	430	107.8	538	4.99	405	118.9	524	4.41
120	7.0	217	103.4	321	3.10	203	115.7	319	2.76	189	131.0	320	2.45
	13.0	276	105.2	381	3.62	259	116.6	376	3.23	242	130.4	372	2.86
	18.0	335	107.0	442	4.13	315	117.9	433	3.67	294	130.9	425	3.26
	24.0	417	108.8	525	4.83	393	119.7	513	4.29	369	132.1	501	3.80
	30.0	514	109.6	624	5.69	486	120.9	607	5.03	458	133.4	591	4.44
150	7.0	250	121.3	372	3.06	234	135.8	370	2.73	217	153.7	371	2.42
	13.0	318	123.5	441	3.58	298	136.8	435	3.19	278	153.0	431	2.82
	18.0	385	125.6	511	4.07	362	138.4	501	3.62	339	153.6	492	3.21
	24.0	480	127.6	607	4.76	452	140.4	593	4.23	424	155.0	579	3.75
	30.0	592	128.6	720	5.60	560	141.9	702	4.95	527	156.5	683	4.38
170	7.0	288	138.2	426	3.09	270	154.7	424	2.75	250	175.1	425	2.44
	13.0	366	140.7	507	3.60	344	155.9	499	3.21	320	174.3	494	2.84
	18.0	443	143.0	587	4.10	417	157.6	575	3.65	390	175.0	565	3.24
	24.0	552	145.4	698	4.80	521	159.9	681	4.26	489	176.6	665	3.78
	30.0	681	146.5	828	5.65	645	161.6	806	5.00	607	178.3	785	4.41
190	7.0	326	155.1	481	3.10	305	173.6	479	2.76	283	196.5	480	2.45
	13.0	414	157.9	572	3.62	389	174.9	564	3.23	362	195.6	558	2.86
	18.0	502	160.5	662	4.13	472	176.9	649	3.67	441	196.4	638	3.26
	24.0	625	163.1	788	4.83	590	179.5	769	4.29	553	198.2	751	3.80
	30.0	771	164.4	935	5.69	729	181.4	911	5.03	686	200.1	887	4.44

NOTE: Performance is based on 4-pass condenser, 5.5-degree C evaporator delta-T, and 11-degree C condenser delta-T. See page 25 for selection information.

Pressure Drop Data

TGZ Scroll

Figure 15, Evaporator Pressure Drop

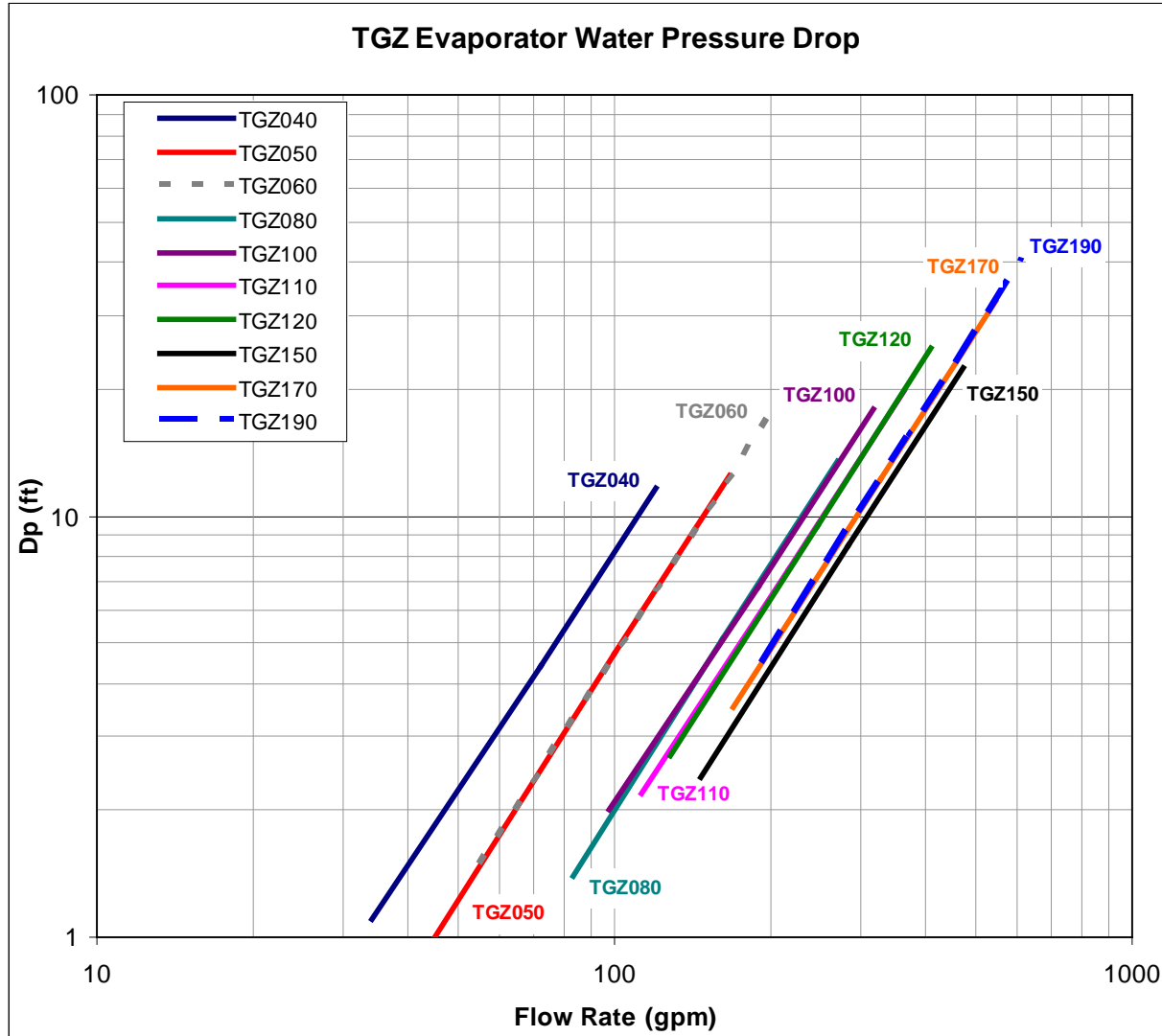

TGZ UNIT MODEL	EVAPORATOR MODEL	MINIMUM FLOW RATE				NOMINAL FLOW RATE				MAXIMUM FLOW RATE			
		INCH-POUND		S.I.		INCH-POUND		S.I.		INCH-POUND		S.I.	
		GPM	FT.	L/S	KPA	GPM	FT.	LPS	KPA	GPM	FT.	LPS	KPA
040A	AC250-70DQ	34	1.1	2.1	3.2	72	4.4	4.5	13.2	120	11.6	7.6	34.7
050A	AC250-94DQ	45	1.0	2.8	3.1	100	4.7	6.3	14.0	167	12.5	10.5	37.2
060A	AC250-94DQ	55	1.5	3.5	4.5	121	6.7	7.6	20.0	202	17.7	12.7	53.0
080A	AC350-162DQ	83	1.4	5.2	4.3	162	5.1	10.2	15.2	270	13.5	17.0	40.2
100A	AC350-162DQ	98	2.0	6.2	5.8	189	6.8	11.9	20.3	315	17.9	19.9	53.6
110A	AC350-182DQ	113	2.2	7.1	6.4	218	7.5	13.8	22.4	363	19.8	22.9	59.1
120A	AC350-182DQ	128	2.7	8.1	8.2	246	9.5	15.5	28.4	410	25.1	25.9	74.9
150A	EV34191111/9	147	2.4	9.3	7.3	283	8.5	17.9	25.4	472	22.5	29.8	67.1
170A	EV34191212/7	169	3.5	10.7	10.5	326	12.2	20.6	36.5	543	32.2	34.3	96.1
190A	EV34191212/7	192	4.5	12.1	13.4	369	15.5	23.3	46.3	615	40.9	38.8	122.3

Note: Nominal Flow Rate is gpm for 10°F Delta-T at unit operating conditions of evaporator at 75/65°F water temp and condenser at 110/30° F water temp.

Figure 16, Standard Four-pass Condenser Pressure Drop

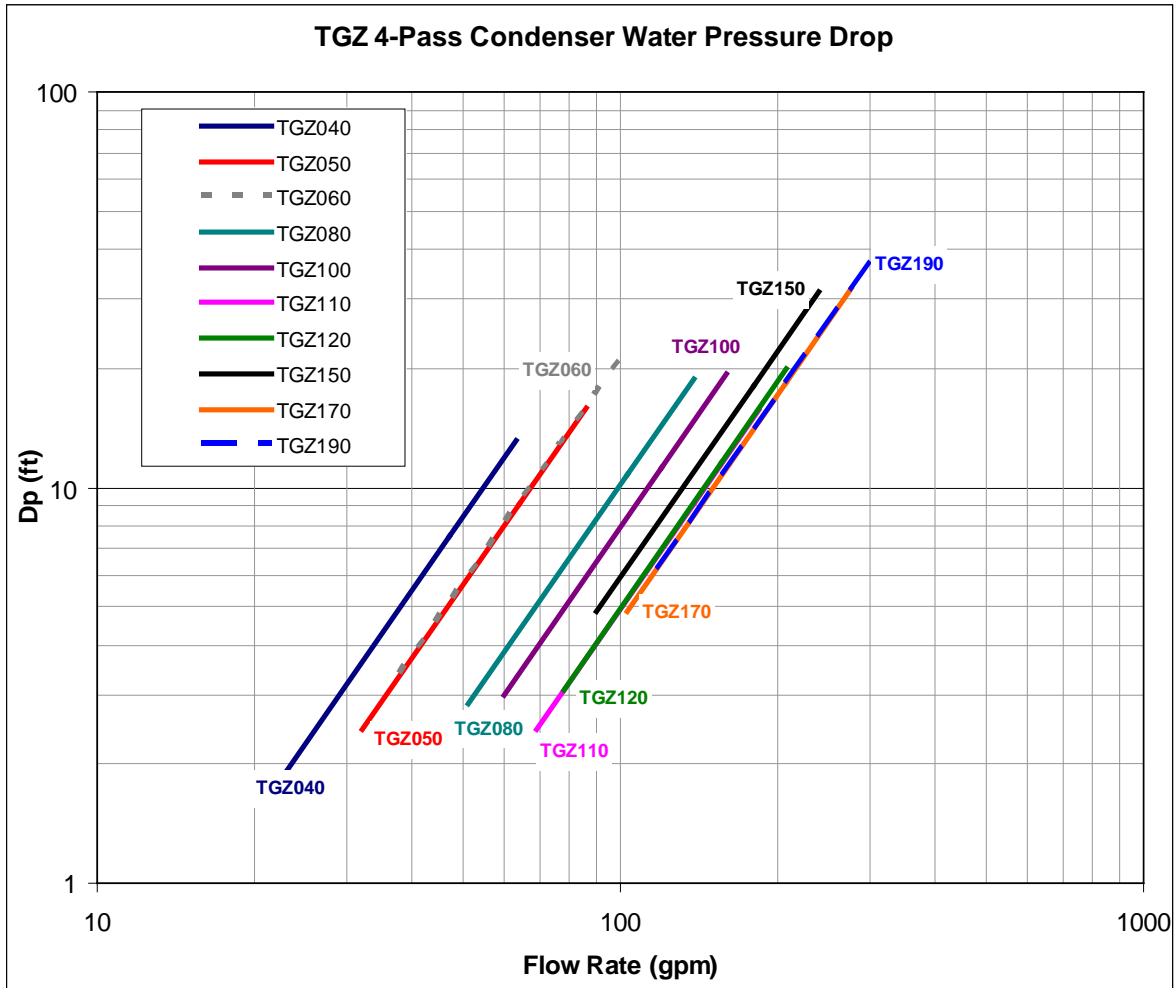

TGZ UNIT MODEL	COND. MODEL	MINIMUM FLOW RATE				NOMINAL FLOW RATE				MAXIMUM FLOW RATE			
		INCH-POUND		S.I.		INCH-POUND		S.I.		INCH-POUND		S.I.	
		GPM	FT	L/S	KPA	GPM	FT	L/S	KPA	GPM	FT	L/S	KPA
TGZ040	C1010-62	23	1.93	1.45	5.77	47	7.5	3.0	22.4	63	13.1	4.0	39.1
TGZ050	C1010-62	32	2.44	2.02	7.29	64	9.1	4.0	27.2	86	16.0	5.4	47.7
TGZ060	C1010-76	38	3.40	2.40	10.16	77	13.0	4.9	38.9	103	22.6	6.5	67.5
TGZ080	C1410-112	51	2.84	3.22	8.49	103	10.8	6.5	32.3	138	18.8	8.7	56.3
TGZ100	C1410-128	60	3.00	3.79	8.97	120	11.2	7.6	33.5	160	19.3	10.1	57.8
TGZ110	C1610-164	69	2.44	4.35	7.29	138	9.1	8.7	27.2	184	15.7	11.6	47.0
TGZ120	C1610-164	78	3.08	4.92	9.21	156	11.5	9.8	34.4	208	19.9	13.1	59.4
TGZ150	C1612-164	90	4.85	5.68	14.50	180	18.1	11.4	54.1	240	31.3	15.1	93.4
TGZ170	C1612-184	103	4.89	6.50	14.60	207	18.4	13.1	55.0	276	31.8	17.4	95.0
TGZ190	C1612-184	117	6.24	7.38	18.66	234	23.3	14.8	69.6	312	40.2	19.7	120.3

Figure 17, Optional Two-pass Condenser

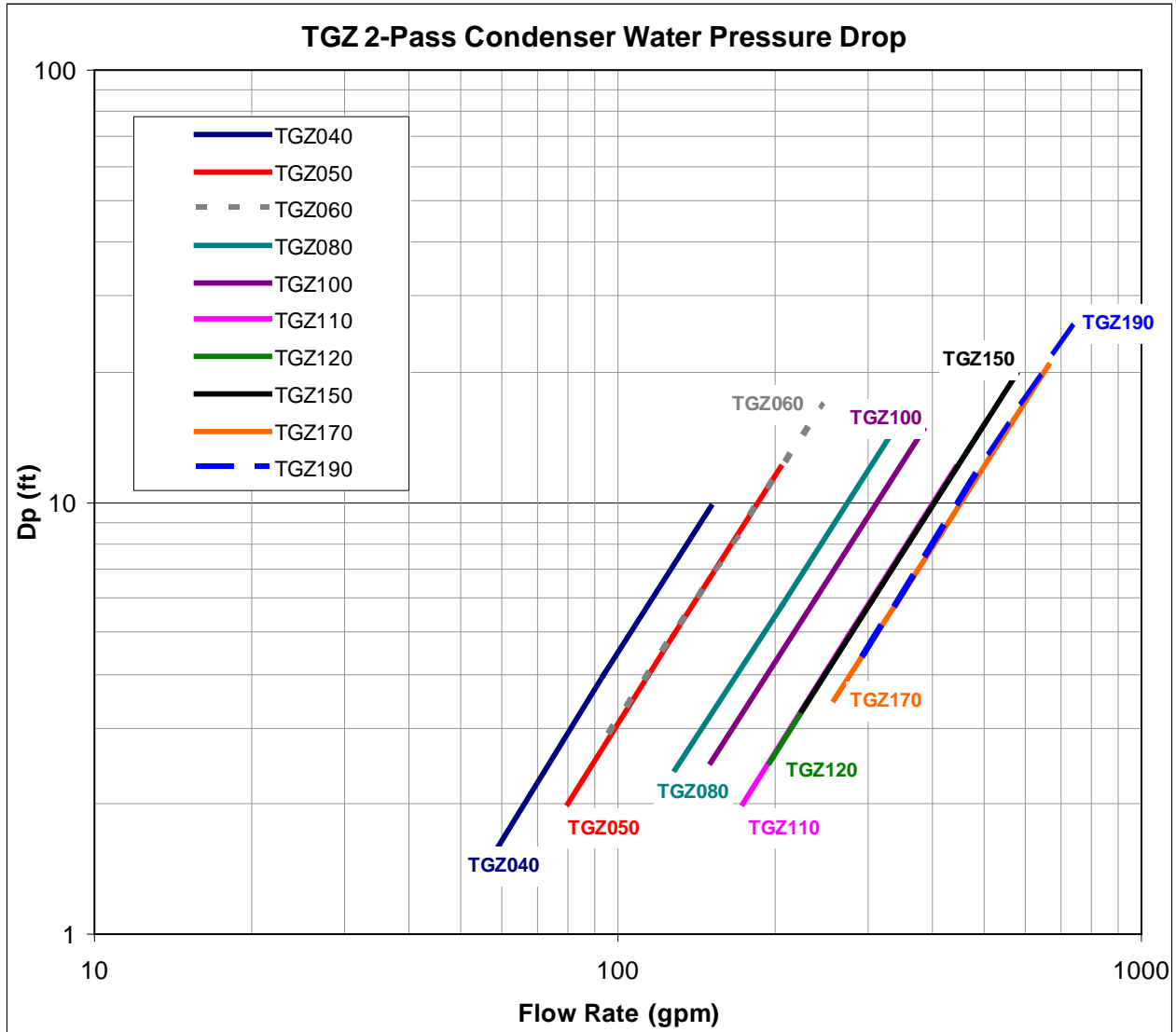

TGZ UNIT MODEL	COND. MODEL.	MINIMUM FLOW RATE				NOMINAL FLOW RATE				MAXIMUM FLOW RATE			
		INCH-POUND		S.I.		INCH-POUND		S.I.		INCH-POUND		S.I.	
		GPM	FT	L/S	KPA	GPM	FT	L/S	KPA	GPM	FT	LPS	KPA
TGZ040	C1010-62	59	1.6	3.7	4.9	94	4.0	5.9	12.0	150	9.8	9.5	29.3
TGZ050	C1010-62	80	2.0	5.0	6.0	128	4.9	8.1	14.6	205	12.0	12.9	35.8
TGZ060	C1010-76	96	2.9	6.1	8.5	154	7.0	9.7	20.9	246	17.0	15.5	51.0
TGZ080	C1410-112	129	2.4	8.1	7.1	206	5.8	13.0	17.3	330	14.2	20.8	42.3
TGZ100	C1410-128	150	2.5	9.5	7.3	240	6.0	15.1	17.9	384	14.7	24.2	43.8
TGZ110	C1610-164	173	2.0	10.9	6.0	276	4.9	17.4	14.6	442	12.0	27.9	35.8
TGZ120	C1610-164	195	2.5	12.3	7.6	312	6.2	19.7	18.5	499	15.1	31.5	45.3
TGZ150	C1612-164	225	3.3	14.2	9.9	360	8.1	22.7	24.2	576	19.8	36.3	59.1
TGZ170	C1612-184	259	3.5	16.3	10.4	414	8.5	26.1	25.4	662	20.8	41.8	62.1
TGZ190	C1612-184	293	4.4	18.5	13.2	468	10.8	29.5	32.3	749	26.4	47.2	78.8

TGZ Electrical Data

Table 11, Compressor Amp Draw

TGZ UNIT SIZE	VOLTS	FREQ. (HERTZ)	STANDARD UNIT W/O EXT. OL'S RATED LOAD AMPS PER COMPRESSOR						OPTIONAL UNIT WITH EXT. OL'S RATED LOAD AMPS (SEE NOTE 1) PER COMPRESSOR						LOCKED ROTOR AMPS COMPRESSORS ACROSS-THE-LINE STARTING					
			CIRCUIT 1			CIRCUIT 2			CIRCUIT 1			CIRCUIT 2			CIRCUIT 1			CIRCUIT 2		
			No.1	No.3	No.5	No.2	No.4	No.6	No.1	No.3	No.5	No.2	No.4	No.6	No.1	No.3	No.5	No.2	No.4	No.6
040	208	60	35.3	35.3	-	35.3	35.3	-	30.8	30.8	-	30.8	30.8	-	239	239	-	239	239	-
	230		35.3	35.3	-	35.3	35.3	-	28.0	28.0	-	28.0	28.0	-	239	239	-	239	239	-
	460		17.9	17.9	-	17.9	17.9	-	14.0	14.0	-	14.0	14.0	-	125	125	-	125	125	-
	575		11.5	11.5	-	11.5	11.5	-	11.2	11.2	-	11.2	11.2	-	80	80	-	80	80	-
050	208	60	48.1	48.1	-	48.1	48.1	-	42.0	42.0	-	42.0	42.0	-	300	300	-	300	300	-
	230		48.1	48.1	-	48.1	48.1	-	38.4	38.4	-	38.4	38.4	-	300	300	-	300	300	-
	460		21.8	21.8	-	21.8	21.8	-	19.2	19.2	-	19.2	19.2	-	150	150	-	150	150	-
	575		19.9	19.9	-	19.9	19.9	-	15.2	15.2	-	15.2	15.2	-	109	109	-	109	109	-
060	208	60	54.0	54.0	-	54.0	54.0	-	54.0	54.0	-	54.0	54.0	-	340	340	-	340	340	-
	230		52.6	52.6	-	52.6	52.6	-	48.8	48.8	-	48.8	48.8	-	340	340	-	340	340	-
	460		25.6	25.6	-	25.6	25.6	-	24.4	24.4	-	24.4	24.4	-	173	173	-	173	173	-
	575		21.2	21.2	-	21.2	21.2	-	19.6	19.6	-	19.6	19.6	-	132	132	-	132	132	-
080	208	60	73.1	73.1	-	73.1	73.1	-	58.0	58.0	-	58.0	58.0	-	505	505	-	505	505	-
	230		73.1	73.1	-	73.1	73.1	-	52.8	52.8	-	52.8	52.8	-	505	505	-	505	505	-
	460		30.1	30.1	-	30.1	30.1	-	26.4	26.4	-	26.4	26.4	-	225	225	-	225	225	-
	575		24.4	24.4	-	24.4	24.4	-	21.2	21.2	-	21.2	21.2	-	180	180	-	180	180	-
100	208	60	73.1	73.1	-	73.1	73.1	-	69.2	69.2	-	69.2	69.2	-	500	500	-	500	500	-
	230		73.1	73.1	-	73.1	73.1	-	62.4	62.4	-	62.4	62.4	-	500	500	-	500	500	-
	460		35.3	35.3	-	35.3	35.3	-	31.2	31.2	-	31.2	31.2	-	250	250	-	250	250	-
	575		28.2	28.2	-	28.2	28.2	-	25.2	25.2	-	25.2	25.2	-	198	198	-	198	198	-
110	208	60	73.1	73.1	-	93.6	93.6	-	69.2	69.2	-	88.8	88.8	-	500	500	-	599	599	-
	230		73.1	73.1	-	93.6	93.6	-	62.4	62.4	-	80.0	80.0	-	500	500	-	599	599	-
	460		35.3	35.3	-	45.5	45.5	-	31.2	31.2	-	40.0	40.0	-	250	250	-	310	310	-
	575		28.2	28.2	-	36.5	36.5	-	25.2	25.2	-	32.0	32.0	-	198	198	-	239	239	-
120	208	60	93.6	93.6	-	93.6	93.6	-	88.8	88.8	-	88.8	88.8	-	599	599	-	599	599	-
	230		93.6	93.6	-	93.6	93.6	-	80.0	80.0	-	80.0	80.0	-	599	599	-	599	599	-
	460		45.5	45.5	-	45.5	45.5	-	40.0	40.0	-	40.0	40.0	-	310	310	-	310	310	-
	575		36.5	36.5	-	36.5	36.5	-	32.0	32.0	-	32.0	32.0	-	239	239	-	239	239	-
150	208	60	73.1	73.1	73.1	73.1	73.1	73.1	69.2	69.2	69.2	69.2	69.2	69.2	500	500	500	500	500	500
	230		73.1	73.1	73.1	73.1	73.1	73.1	62.4	62.4	62.4	62.4	62.4	62.4	500	500	500	500	500	500
	460		35.3	35.3	35.3	35.3	35.3	35.3	31.2	31.2	31.2	31.2	31.2	31.2	250	250	250	250	250	250
	575		28.2	28.2	28.2	28.2	28.2	28.2	25.2	25.2	25.2	25.2	25.2	25.2	198	198	198	198	198	198
170	208	60	73.1	73.1	73.1	93.6	93.6	93.6	69.2	69.2	69.2	88.8	88.8	88.8	500	500	500	599	599	599
	230		73.1	73.1	73.1	93.6	93.6	93.6	62.4	62.4	62.4	80.0	80.0	80.0	500	500	500	599	599	599
	460		35.3	35.3	35.3	45.5	45.5	45.5	31.2	31.2	31.2	40.0	40.0	40.0	250	250	250	310	310	310
	575		28.2	28.2	28.2	36.5	36.5	36.5	25.2	25.2	25.2	32.0	32.0	32.0	198	198	198	239	239	239
190	208	60	93.6	93.6	93.6	93.6	93.6	93.6	88.8	88.8	88.8	88.8	88.8	88.8	599	599	599	599	599	599
	230		93.6	93.6	93.6	93.6	93.6	93.6	80.0	80.0	80.0	80.0	80.0	80.0	599	599	599	599	599	599
	460		45.5	45.5	45.5	45.5	45.5	45.5	40.0	40.0	40.0	40.0	40.0	40.0	310	310	310	310	310	310
	575		36.5	36.5	36.5	36.5	36.5	36.5	32.0	32.0	32.0	32.0	32.0	32.0	239	239	239	239	239	239

NOTES:

- External overloads only available on Templifier units with 140°F maximum condenser leaving water temperature.
- Unit wire sizing amps are equal to 125% of the largest compressor-motor RLA plus 100% of RLA of all other loads in the circuit including control transformer.
- Single point power supply requires a single fused disconnect to supply electrical power to the unit.
- Compressor RLA values are for wire sizing purposes only and do not reflect normal operating current draw.

Table 12, Wire Sizing Amps, Standard Multi-Point Power Supply

TGZ UNIT SIZE	VOLTS	FREQ. (HERTZ)	MINIMUM CIRCUIT AMPACITY (MCA)				POWER SUPPLY							
			WITHOUT EXTERNAL OVERLOADS		WITH EXTERNAL OVERLOADS		WITHOUT EXTERNAL OVERLOADS			WITH EXTERNAL OVERLOADS				
			MULTIPLE POINT POWER SUPPLY						FIELD WIRE QTY.	WIRE GAUGE 75°C		FIELD WIRE QTY.	WIRE GAUGE 75°C	
			CIRCUIT #1	CIRCUIT #2	CIRCUIT #1	CIRCUIT #2	CIRCUIT #1	CIRCUIT #2		CIRCUIT #1	CIRCUIT #2		CIRCUIT #1	CIRCUIT #2
040	208	60	79	79	69	69	3	#4	#4	3	#4	#4		
	230		79	79	63	63	3	#4	#4	3	#6	#6		
	460		40	40	32	32	3	#8	#8	3	#10	#10		
	575		26	26	25	25	3	#10	#10	3	#10	#10		
050	208	60	108	108	95	95	3	#2	#2	3	#3	#3		
	230		108	108	86	86	3	#2	#2	3	#3	#3		
	460		49	49	43	43	3	#8	#8	3	#8	#8		
	575		45	45	34	34	3	#8	#8	3	#10	#10		
060	208	60	122	122	122	122	3	#1	#1	3	#1	#1		
	230		118	118	110	110	3	#1	#1	3	#2	#2		
	460		58	58	55	55	3	#6	#6	3	#6	#6		
	575		48	48	44	44	3	#8	#8	3	#8	#8		
080	208	60	165	165	131	131	3	2/0	2/0	3	1/0	1/0		
	230		165	165	119	119	3	2/0	2/0	3	#1	#1		
	460		68	68	59	59	3	#4	#4	3	#6	#6		
	575		55	55	48	48	3	#6	#6	3	#8	#8		
100	208	60	165	165	156	156	3	2/0	2/0	3	2/0	2/0		
	230		165	165	140	140	3	2/0	2/0	3	1/0	1/0		
	460		79	79	70	70	3	#4	#4	3	#4	#4		
	575		64	64	57	57	3	#6	#6	3	#6	#6		
110	208	60	165	211	156	200	3	2/0	4/0	3	2/0	3/0		
	230		165	211	140	180	3	2/0	4/0	3	1/0	3/0		
	460		79	102	70	90	3	#4	#2	3	#4	#3		
	575		64	82	57	72	3	#6	#4	3	#6	#4		
120	208	60	211	211	200	200	3	4/0	4/0	3	3/0	3/0		
	230		211	211	180	180	3	4/0	4/0	3	3/0	3/0		
	460		102	102	90	90	3	#2	#2	3	#3	#3		
	575		82	82	72	72	3	#4	#4	3	#4	#4		
150	208	60	238	238	225	225	3	250	250	3	4/0	4/0		
	230		238	238	203	203	3	250	250	3	4/0	4/0		
	460		115	115	101	101	3	#2	#2	3	#2	#2		
	575		92	92	82	82	3	#3	#3	3	#4	#4		
170	208	60	238	304	225	289	3	250	350	3	4/0	350		
	230		238	304	203	260	3	250	350	3	4/0	300		
	460		115	148	101	130	3	#2	1/0	3	#2	#1		
	575		92	119	82	104	3	#3	#1	3	#4	#2		
190	208	60	304	304	289	289	3	350	350	3	350	350		
	230		304	304	260	260	3	350	350	3	300	300		
	460		148	148	130	130	3	1/0	1/0	3	#1	#1		
	575		119	119	104	104	3	#1	#1	3	#2	#2		

NOTES:

1. Unit wire sizing amps are equal to 125% of the largest compressor-motor RLA plus 100% of the other compressor RLA's.
2. Multiple point power supply requires a separate fused disconnect for each circuit to supply electrical power to the unit.
3. External compressor overload option is only available for units with 140° F maximum leaving condenser water temperature.
4. Wire sizes shown above are for standard ambient temperature and short runs of wire.

Table 13, Wire Sizing Amps, Optional Single Point Power Supply

TGZ UNIT SIZE	VOLTS	MINIMUM CIRCUIT AMPACITY (MCA)		POWER SUPPLY			
		SINGLE POINT POWER SUPPLY) WITHOUT EXT OL'S	SINGLE POINT POWER SUPPLY WITH EXT OL'S	WITHOUT EXTERNAL OL'S FIELD WIRE QUANTITY	WIRE GAUGE 75°C	WITH EXTERNAL OL'S FIELD WIRE QUANTITY	WIRE GAUGE 75°C
040	208	150	131	3	1/0	3	1/0
	230	150	119	3	1/0	3	#1
	460	76	60	3	#4	3	#6
	575	49	48	3	#8	3	#8
050	208	204	179	3	4/0	3	3/0
	230	204	163	3	4/0	3	2/0
	460	93	82	3	#3	3	#4
	575	85	65	3	#4	3	#6
060	208	230	230	3	4/0	3	4/0
	230	224	207	3	4/0	3	4/0
	460	109	104	3	#2	3	#2
	575	90	83	3	#3	3	#4
080	208	311	247	3	400	3	250
	230	311	224	3	400	3	4/0
	460	128	112	3	#1	3	#2
	575	104	90	3	#2	3	#3
100	208	311	294	3	400	3	350
	230	311	265	3	400	3	300
	460	150	133	3	1/0	3	1/0
	575	120	107	3	#1	3	#2
110	208	357	338	6 (2)	3/0	6 (2)	2/0
	230	357	305	6 (2)	3/0	3	350
	460	173	152	3	2/0	3	2/0
	575	139	122	3	1/0	3	#1
120	208	398	377	6 (2)	3/0	6 (2)	3/0
	230	398	340	6 (2)	3/0	6 (2)	2/0
	460	193	170	3	3/0	3	2/0
	575	155	136	3	2/0	3	1/0
150	208	457	433	6 (2)	4/0	6 (2)	4/0
	230	457	390	6 (2)	4/0	6 (2)	3/0
	460	221	195	3	4/0	3	3/0
	575	176	158	3	3/0	3	2/0
170	208	524	496	6 (2)	300	6 (2)	250
	230	524	447	6 (2)	300	6 (2)	4/0
	460	254	224	3	250	3	4/0
	575	203	180	3	4/0	3	3/0
190	208	585	555	6 (2)	350	6 (2)	300
	230	585	500	6 (2)	350	6 (2)	250
	460	284	250	3	300	3	250
	575	228	200	3	4/0	3	3/0

NOTES:

1. Unit wire sizing amps are equal to 125% of the largest compressor-motor RLA plus 100% of the other compressor RLA's.
2. Single point power supply requires a single fused disconnect to supply electrical power to the unit.
3. External compressor overload option is only available for units with 140° F maximum leaving condenser water temperature.
4. Wire Sizes shown above are for standard ambient temperature and short runs of wire.

Table 14, Maximum Fuse Sizing

TGZ UNIT SIZE	VOLTS	FREQ. (HERTZ)	SINGLE POINT POWER SUPPLY		MULTIPLE POINT POWER SUPPLY			
			WITHOUT EXTERNAL OL'S TOTAL UNIT	WITH EXTERNAL OL'S TOTAL UNIT	WITHOUT EXTERNAL OL'S		WITH EXTERNAL OL'S	
					CIRC.#1	CIRC.#2	CIRC.#1	CIRC.#2
040	208	60	175	150	110	110	100	100
	230		175	125	110	110	90	90
	460		90	70	50	50	45	45
	575		60	50	35	35	35	35
050	208	60	250	200	150	150	125	125
	230		250	200	150	150	110	110
	460		110	100	70	70	60	60
	575		100	70	60	60	45	45
060	208	60	250	250	175	175	175	175
	230		250	250	150	150	150	150
	460		125	125	80	80	70	70
	575		110	100	60	60	60	60
080	208	60	350	300	225	225	175	175
	230		350	250	225	225	150	150
	460		150	125	90	90	80	80
	575		125	110	70	70	60	60
100	208	60	350	350	225	225	200	200
	230		350	300	225	225	200	200
	460		175	150	110	110	100	100
	575		125	125	90	90	80	80
110	208	60	450	400	225	300	200	250
	230		450	350	225	300	200	250
	460		200	175	110	125	100	125
	575		175	150	90	110	80	100
120	208	60	450	450	300	300	250	250
	230		450	400	300	300	250	250
	460		225	200	125	125	125	125
	575		175	150	110	110	100	100
150	208	60	500	500	300	300	250	250
	230		500	450	300	300	250	250
	460		250	225	150	150	125	125
	575		200	175	110	110	100	100
170	208	60	600	500	300	350	250	350
	230		600	500	300	350	250	300
	460		300	300	150	175	125	150
	575		225	200	110	150	100	125
190	208	60	600	600	350	350	350	350
	230		600	500	350	350	300	300
	460		300	250	175	175	150	150
	575		350	225	150	150	125	125

NOTE:

1. "Maximum Fuse Sizes" are selected at approximately 225% of the largest compressor RLA plus 100% of other compressor RLA values.

Table 15, Connection Sizes, Single Point Power Supply, Without External Overloads

TGZ UNIT SIZE	VOLTS	FREQ. (HERTZ)	POWER BLOCK TERMINAL		FACTORY INSTALLED		FACTORY INSTALLED HSCCR	
			POWER BLOCK OR		DISCONNECT SWITCH		DISCONNECT SWITCH	
			SIZE (1)	CONNECTION (2) WIRE RANGE - CU	SWITCH SIZE (1)	CONNECTION (2) WIRE RANGE - CU	CIRC. SIZE (1)	CONNECTION (2) WIRE RANGE - CU
040	208	60	380	#4 - 500 kcmil	250	#6 - 350 kcmil	250	#6 - 350 kcmil
	230		380	#4 - 500 kcmil	250	#6 - 350 kcmil	250	#6 - 350 kcmil
	460		175	#14 - 2/0	100	#10 - 1/0	150	#6 - 350 kcmil
	575		175	#14 - 2/0	100	#10 - 1/0	90	#10 - 1/0
050	208	60	380	#4 - 500 kcmil	250	#6 - 350 kcmil	350	(2) 3/0 - 500 kcmil
	230		380	#4 - 500 kcmil	250	#6 - 350 kcmil	350	(2) 3/0 - 500 kcmil
	460		175	#14 - 2/0	125	#3 - 3/0	175	#6 - 350 kcmil
	575		175	#14 - 2/0	100	#10 - 1/0	150	#6 - 350 kcmil
060	208	60	380	#4 - 500 kcmil	250	#6 - 350 kcmil	400	(2) 3/0 - 500 kcmil
	230		380	#4 - 500 kcmil	250	#6 - 350 kcmil	400	(2) 3/0 - 500 kcmil
	460		175	#14 - 2/0	125	#3 - 3/0	200	#6 - 350 kcmil
	575		175	#14 - 2/0	100	#10 - 1/0	150	#6 - 350 kcmil
080	208	60	380	#4 - 500 kcmil	400	(2) 3/0 - 500 kcmil	400	(2) 3/0 - 500 kcmil
	230		380	#4 - 500 kcmil	400	(2) 3/0 - 500 kcmil	400	(2) 3/0 - 500 kcmil
	460		175	#14 - 2/0	250	#6 - 350 kcmil	225	#6 - 350 kcmil
	575		175	#14 - 2/0	125	#3 - 3/0	175	#6 - 350 kcmil
100	208	60	380	#4 - 500 kcmil	400	(2) 3/0 - 500 kcmil	600	(2) 3/0 - 500 kcmil
	230		380	#4 - 500 kcmil	400	(2) 3/0 - 500 kcmil	600	(2) 3/0 - 500 kcmil
	460		175	#14 - 2/0	250	#6 - 350 kcmil	250	#6 - 350 kcmil
	575		175	#14 - 2/0	250	#6 - 350 kcmil	200	#6 - 350 kcmil
110	208	60	380	#4 - 500 kcmil	400	(2) 3/0 - 500 kcmil	600	(2) 3/0 - 500 kcmil
	230		380	#4 - 500 kcmil	400	(2) 3/0 - 500 kcmil	600	(2) 3/0 - 500 kcmil
	460		380	#4 - 500 kcmil	250	#6 - 350 kcmil	300	(2) 3/0 - 500 kcmil
	575		175	#14 - 2/0	250	#6 - 350 kcmil	250	#6 - 350 kcmil
120	208	60	760	(2) #2 - 500 kcmil	600	(2) 3/0 - 500 kcmil	700	(2) 3/0 - 500 kcmil
	230		760	(2) #2 - 500 kcmil	600	(2) 3/0 - 500 kcmil	700	(2) 3/0 - 500 kcmil
	460		380	#4 - 500 kcmil	250	#6 - 350 kcmil	400	(2) 3/0 - 500 kcmil
	575		175	#14 - 2/0	250	#6 - 350 kcmil	300	(2) 3/0 - 500 kcmil
150	208	60	760	(2) #2 - 500 kcmil	600	(2) 3/0 - 500 kcmil	800	(3) 1/0 - 500 kcmil
	230		760	(2) #2 - 500 kcmil	600	(2) 3/0 - 500 kcmil	800	(3) 1/0 - 500 kcmil
	460		380	#4 - 500 kcmil	250	#6 - 350 kcmil	400	(2) 3/0 - 500 kcmil
	575		380	#4 - 500 kcmil	250	#6 - 350 kcmil	300	(2) 3/0 - 500 kcmil
170	208	60	760	(2) #2 - 500 kcmil	600	(2) 3/0 - 500 kcmil	1000	(3) 1/0 - 500 kcmil
	230		760	(2) #2 - 500 kcmil	600	(2) 3/0 - 500 kcmil	1000	(3) 1/0 - 500 kcmil
	460		380	#4 - 500 kcmil	400	(2) 3/0 - 500 kcmil	450	(2) 3/0 - 500 kcmil
	575		380	#4 - 500 kcmil	250	#6 - 350 kcmil	350	(2) 3/0 - 500 kcmil
190	208	60	760	(2) #2 - 500 kcmil	800	(3) 1/0 - 500 kcmil	1000	(3) 1/0 - 500 kcmil
	230		760	(2) #2 - 500 kcmil	800	(3) 1/0 - 500 kcmil	1000	(3) 1/0 - 500 kcmil
	460		380	#4 - 500 kcmil	400	(2) 3/0 - 500 kcmil	500	(2) 3/0 - 500 kcmil
	575		380	#4 - 500 kcmil	400	(2) 3/0 - 500 kcmil	400	(2) 3/0 - 500 kcmil

NOTES:.

1. "Size" is the maximum amperage rating for the terminals or the main electrical device...
2. "Connection" is the range of wire sizes that the terminals on the electrical device will accept.

Table 16, Connection Sizes, Single Point Power Supply with External Overloads

TGZ UNIT SIZE	VOLTS	FREQ. (HERTZ)	POWER BLOCK TERMINAL		FACTORY INSTALLED DISCONNECT		FACTORY INSTALLED HSCCR	
			POWER BLOCK OR BUS BAR LUGS		DISCONNECT SWITCH MOLDED CASE		DISCONNECT SWITCH (CIRCUIT BREAKER)	
			SIZE (1)	CONNECTION (2) WIRE RANGE - CU	SWITCH SIZE (1)	CONNECTION (2) WIRE RANGE - CU	CIRC. BRKR SIZE (1)	CONNECTION (2) WIRE RANGE - CU
040	208	60	335	#6 - 400 kcmil	250	#6 - 350 kcmil	250	#6 - 350 kcmil
	230		335	#6 - 400 kcmil	250	#6 - 350 kcmil	250	#6 - 350 kcmil
	460		175	#14 - 2/0	100	#3 - 3/0	150	#4 - 350 kcmil
	575		175	#14 - 2/0	100	#3 - 3/0	150	#4 - 350 kcmil
050	208	60	335	#6 - 400 kcmil	250	#6 - 350 kcmil	250	#6 - 350 kcmil
	230		335	#6 - 400 kcmil	250	#6 - 350 kcmil	250	#6 - 350 kcmil
	460		175	#14 - 2/0	125	#3 - 3/0	125	#3 - 3/0
	575		175	#14 - 2/0	100	#3 - 3/0	100	#3 - 3/0
060	208	60	335	#6 - 400 kcmil	250	#6 - 350 kcmil	400	(2) 3/0 - 500 kcmil
	230		335	#6 - 400 kcmil	250	#6 - 350 kcmil	400	(2) 3/0 - 500 kcmil
	460		175	#14 - 2/0	125	#3 - 3/0	125	#3 - 3/0
	575		175	#14 - 2/0	100	#3 - 3/0	125	#3 - 3/0
080	208	60	760	(2) #2 - 500 kcmil	400	(2) 3/0 - 500 kcmil	400	(2) 3/0 - 500 kcmil
	230		760	(2) #2 - 500 kcmil	400	(2) 3/0 - 500 kcmil	400	(2) 3/0 - 500 kcmil
	460		335	#6 - 400 kcmil	250	#6 - 350 kcmil	250	#6 - 350 kcmil
	575		335	#6 - 400 kcmil	125	#3 - 3/0	125	#3 - 3/0
100	208	60	760	(2) #2 - 500 kcmil	400	(2) 3/0 - 500 kcmil	600	(2) 3/0 - 500 kcmil
	230		760	(2) #2 - 500 kcmil	400	(2) 3/0 - 500 kcmil	600	(2) 3/0 - 500 kcmil
	460		335	#6 - 400 kcmil	250	#6 - 350 kcmil	250	#6 - 350 kcmil
	575		335	#6 - 400 kcmil	250	#6 - 350 kcmil	250	#6 - 350 kcmil
110	208	60	760	(2) #2 - 500 kcmil	400	(2) 3/0 - 500 kcmil	600	(2) 3/0 - 500 kcmil
	230		760	(2) #2 - 500 kcmil	400	(2) 3/0 - 500 kcmil	600	(2) 3/0 - 500 kcmil
	460		335	#6 - 400 kcmil	250	#6 - 350 kcmil	250	#6 - 350 kcmil
	575		335	#6 - 400 kcmil	250	#6 - 350 kcmil	250	#6 - 350 kcmil
120	208	60	760	(2) #2 - 500 kcmil	600	(2) 3/0 - 500 kcmil	600	(2) 3/0 - 500 kcmil
	230		760	(2) #2 - 500 kcmil	600	(2) 3/0 - 500 kcmil	600	(2) 3/0 - 500 kcmil
	460		335	#6 - 400 kcmil	250	#6 - 350 kcmil	400	(2) 3/0 - 500 kcmil
	575		335	#6 - 400 kcmil	250	#6 - 350 kcmil	250	#6 - 350 kcmil
150	208	60	760	(2) #2 - 500 kcmil	600	(2) 3/0 - 500 kcmil	800	(3) 1/0 - 500 kcmil
	230		760	(2) #2 - 500 kcmil	600	(2) 3/0 - 500 kcmil	800	(3) 1/0 - 500 kcmil
	460		335	#6 - 400 kcmil	250	#6 - 350 kcmil	400	(2) 3/0 - 500 kcmil
	575		335	#6 - 400 kcmil	250	#6 - 350 kcmil	250	#6 - 350 kcmil
170	208	60	760	(2) #2 - 500 kcmil	800	(3) 1/0 - 500 kcmil	800	(3) 1/0 - 500 kcmil
	230		760	(2) #2 - 500 kcmil	800	(3) 1/0 - 500 kcmil	800	(3) 1/0 - 500 kcmil
	460		335	#6 - 400 kcmil	400	(2) 3/0 - 500 kcmil	400	(2) 3/0 - 500 kcmil
	575		335	#6 - 400 kcmil	250	#6 - 350 kcmil	400	(2) 3/0 - 500 kcmil
190	208	60	760	(2) #2 - 500 kcmil	800	(3) 1/0 - 500 kcmil	800	(3) 1/0 - 500 kcmil
	230		760	(2) #2 - 500 kcmil	800	(3) 1/0 - 500 kcmil	800	(3) 1/0 - 500 kcmil
	460		335	#6 - 400 kcmil	400	(2) 3/0 - 500 kcmil	400	(2) 3/0 - 500 kcmil
	575		335	#6 - 400 kcmil	400	(2) 3/0 - 500 kcmil	400	(2) 3/0 - 500 kcmil

NOTES:

1. "Size" is the maximum amperage rating for the terminals or the main electrical device.
2. "Connection" is the range of wire sizes that the terminals on the electrical device will accept.

Table 17, Connection Sizes, Multi-Point Power Connection, without External Overloads

TGZ UNIT SIZE	VOLTS	POWER TERMINAL BLOCK				FACTORY INSTALLED DISCONNECT			
		CIRCUIT #1		CIRCUIT #2		CIRCUIT #1		CIRCUIT #2	
		POWER BLOCK/ BUS BAR LUGS SIZE	CONN. WIRE RANGE	POWER BLOCK/ BUS BAR LUGS SIZE	CONN. WIRE RANGE	MOLDED CASE			
						SWITCH SIZE	CONNECTION WIRE RANGE	SWITCH SIZE	CONNECTION WIRE RANGE
040	208	175	#14 - 2/0	175	#14 - 2/0	100	#10 - 1/0	100	#10 - 1/0
	230	175	#14 - 2/0	175	#14 - 2/0	100	#10 - 1/0	100	#10 - 1/0
	460	175	#14 - 2/0	175	#14 - 2/0	100	#10 - 1/0	100	#10 - 1/0
	575	175	#14 - 2/0	175	#14 - 2/0	100	#10 - 1/0	100	#10 - 1/0
050	208	175	#14 - 2/0	175	#14 - 2/0	125	#3 - 3/0	125	#3 - 3/0
	230	175	#14 - 2/0	175	#14 - 2/0	125	#3 - 3/0	125	#3 - 3/0
	460	175	#14 - 2/0	175	#14 - 2/0	100	#10 - 1/0	100	#10 - 1/0
	575	175	#14 - 2/0	175	#14 - 2/0	100	#10 - 1/0	100	#10 - 1/0
060	208	175	#14 - 2/0	175	#14 - 2/0	125	#3 - 3/0	125	#3 - 3/0
	230	175	#14 - 2/0	175	#14 - 2/0	125	#3 - 3/0	125	#3 - 3/0
	460	175	#14 - 2/0	175	#14 - 2/0	100	#10 - 1/0	100	#10 - 1/0
	575	175	#14 - 2/0	175	#14 - 2/0	100	#10 - 1/0	100	#10 - 1/0
080	208	175	#14 - 2/0	175	#14 - 2/0	250	#6 - 350 kcmil	250	#6 - 350 kcmil
	230	175	#14 - 2/0	175	#14 - 2/0	250	#6 - 350 kcmil	250	#6 - 350 kcmil
	460	175	#14 - 2/0	175	#14 - 2/0	100	#10 - 1/0	100	#10 - 1/0
	575	175	#14 - 2/0	175	#14 - 2/0	100	#10 - 1/0	100	#10 - 1/0
100	208	175	#14 - 2/0	175	#14 - 2/0	250	#6 - 350 kcmil	250	#6 - 350 kcmil
	230	175	#14 - 2/0	175	#14 - 2/0	250	#6 - 350 kcmil	250	#6 - 350 kcmil
	460	175	#14 - 2/0	175	#14 - 2/0	100	#10 - 1/0	100	#10 - 1/0
	575	175	#14 - 2/0	175	#14 - 2/0	100	#10 - 1/0	100	#10 - 1/0
110	208	380	#4 - 500 kcmil	380	#4 - 500 kcmil	250	#6 - 350 kcmil	250	#6 - 350 kcmil
	230	380	#4 - 500 kcmil	380	#4 - 500 kcmil	250	#6 - 350 kcmil	250	#6 - 350 kcmil
	460	175	#14 - 2/0	175	#14 - 2/0	100	#10 - 1/0	125	#3 - 3/0
	575	175	#14 - 2/0	175	#14 - 2/0	100	#10 - 1/0	100	#10 - 1/0
120	208	380	#4 - 500 kcmil	380	#4 - 500 kcmil	250	#6 - 350 kcmil	250	#6 - 350 kcmil
	230	380	#4 - 500 kcmil	380	#4 - 500 kcmil	250	#6 - 350 kcmil	250	#6 - 350 kcmil
	460	175	#14 - 2/0	175	#14 - 2/0	125	#3 - 3/0	125	#3 - 3/0
	575	175	#14 - 2/0	175	#14 - 2/0	100	#10 - 1/0	100	#10 - 1/0
150	208	380	#4 - 500 kcmil	380	#4 - 500 kcmil	400	(2) 3/0 - 500 kcmil	400	(2) 3/0 - 500 kcmil
	230	380	#4 - 500 kcmil	380	#4 - 500 kcmil	400	(2) 3/0 - 500 kcmil	400	(2) 3/0 - 500 kcmil
	460	175	#14 - 2/0	175	#14 - 2/0	125	#3 - 3/0	125	#3 - 3/0
	575	175	#14 - 2/0	175	#14 - 2/0	125	#3 - 3/0	125	#3 - 3/0
170	208	380	#4 - 500 kcmil	380	#4 - 500 kcmil	400	(2) 3/0 - 500 kcmil	400	(2) 3/0 - 500 kcmil
	230	380	#4 - 500 kcmil	380	#4 - 500 kcmil	400	(2) 3/0 - 500 kcmil	400	(2) 3/0 - 500 kcmil
	460	175	#14 - 2/0	175	#14 - 2/0	250	#6 - 350 kcmil	250	#6 - 350 kcmil
	575	175	#14 - 2/0	175	#14 - 2/0	125	#3 - 3/0	250	#6 - 350 kcmil
190	208	380	#4 - 500 kcmil	380	#4 - 500 kcmil	400	(2) 3/0 - 500 kcmil	400	(2) 3/0 - 500 kcmil
	230	380	#4 - 500 kcmil	380	#4 - 500 kcmil	400	(2) 3/0 - 500 kcmil	400	(2) 3/0 - 500 kcmil
	460	175	#14 - 2/0	175	#14 - 2/0	250	#6 - 350 kcmil	250	#6 - 350 kcmil
	575	175	#14 - 2/0	175	#14 - 2/0	250	#6 - 350 kcmil	250	#6 - 350 kcmil

Table 18, Connection Sizes, Multi-Point Power Connection, with External Overloads

TGZ UNIT SIZE	VOLTS	POWER TERMINAL BLOCK				FACTORY INSTALLED DISCONNECT			
		CIRCUIT #1		CIRCUIT #2		CIRCUIT #1		CIRCUIT #2	
		POWER BLOCK OR BUS BAR LUGS SIZE	CONN. WIRE RANGE	POWER BLOCK OR BUS BAR LUGS SIZE	CONN. WIRE RANGE	MOLDED CASE			
						SWITCH SIZE	CONN. WIRE RANGE	SWITCH SIZE	CONN. WIRE RANGE -
040	208	175	#14 - 2/0	175	#14 - 2/0	100	#10 - 1/0	100	#10 - 1/0
	230	175	#14 - 2/0	175	#14 - 2/0	100	#10 - 1/0	100	#10 - 1/0
	460	175	#14 - 2/0	175	#14 - 2/0	100	#10 - 1/0	100	#10 - 1/0
	575	175	#14 - 2/0	175	#14 - 2/0	100	#10 - 1/0	100	#10 - 1/0
050	208	175	#14 - 2/0	175	#14 - 2/0	125	#3 - 3/0	125	#3 - 3/0
	230	175	#14 - 2/0	175	#14 - 2/0	125	#3 - 3/0	125	#3 - 3/0
	460	175	#14 - 2/0	175	#14 - 2/0	100	#10 - 1/0	100	#10 - 1/0
	575	175	#14 - 2/0	175	#14 - 2/0	100	#10 - 1/0	100	#10 - 1/0
060	208	175	#14 - 2/0	175	#14 - 2/0	125	#3 - 3/0	125	#3 - 3/0
	230	175	#14 - 2/0	175	#14 - 2/0	125	#3 - 3/0	125	#3 - 3/0
	460	175	#14 - 2/0	175	#14 - 2/0	100	#10 - 1/0	100	#10 - 1/0
	575	175	#14 - 2/0	175	#14 - 2/0	100	#10 - 1/0	100	#10 - 1/0
080	208	175	#14 - 2/0	175	#14 - 2/0	250	#6 - 350 kcmil	250	#6 - 350 kcmil
	230	175	#14 - 2/0	175	#14 - 2/0	250	#6 - 350 kcmil	250	#6 - 350 kcmil
	460	175	#14 - 2/0	175	#14 - 2/0	100	#10 - 1/0	100	#10 - 1/0
	575	175	#14 - 2/0	175	#14 - 2/0	100	#10 - 1/0	100	#10 - 1/0
100	208	175	#14 - 2/0	175	#14 - 2/0	250	#6 - 350 kcmil	250	#6 - 350 kcmil
	230	175	#14 - 2/0	175	#14 - 2/0	250	#6 - 350 kcmil	250	#6 - 350 kcmil
	460	175	#14 - 2/0	175	#14 - 2/0	100	#10 - 1/0	100	#10 - 1/0
	575	175	#14 - 2/0	175	#14 - 2/0	100	#10 - 1/0	100	#10 - 1/0
110	208	380	#4 - 500 kcmil	380	#4 - 500 kcmil	250	#6 - 350 kcmil	250	#6 - 350 kcmil
	230	380	#4 - 500 kcmil	380	#4 - 500 kcmil	250	#6 - 350 kcmil	250	#6 - 350 kcmil
	460	175	#14 - 2/0	175	#14 - 2/0	100	#10 - 1/0	125	#3 - 3/0
	575	175	#14 - 2/0	175	#14 - 2/0	100	#10 - 1/0	100	#10 - 1/0
120	208	380	#4 - 500 kcmil	380	#4 - 500 kcmil	250	#6 - 350 kcmil	250	#6 - 350 kcmil
	230	380	#4 - 500 kcmil	380	#4 - 500 kcmil	250	#6 - 350 kcmil	250	#6 - 350 kcmil
	460	175	#14 - 2/0	175	#14 - 2/0	125	#3 - 3/0	125	#3 - 3/0
	575	175	#14 - 2/0	175	#14 - 2/0	100	#10 - 1/0	100	#10 - 1/0
150	208	380	#4 - 500 kcmil	380	#4 - 500 kcmil	400	(2) 3/0 - 500 kcmil	400	(2) 3/0 - 500 kcmil
	230	380	#4 - 500 kcmil	380	#4 - 500 kcmil	400	(2) 3/0 - 500 kcmil	400	(2) 3/0 - 500 kcmil
	460	175	#14 - 2/0	175	#14 - 2/0	125	#3 - 3/0	125	#3 - 3/0
	575	175	#14 - 2/0	175	#14 - 2/0	125	#3 - 3/0	125	#3 - 3/0
170	208	380	#4 - 500 kcmil	380	#4 - 500 kcmil	400	(2) 3/0 - 500 kcmil	400	(2) 3/0 - 500 kcmil
	230	380	#4 - 500 kcmil	380	#4 - 500 kcmil	400	(2) 3/0 - 500 kcmil	400	(2) 3/0 - 500 kcmil
	460	175	#14 - 2/0	175	#14 - 2/0	250	#6 - 350 kcmil	250	#6 - 350 kcmil
	575	175	#14 - 2/0	175	#14 - 2/0	125	#3 - 3/0	250	#6 - 350 kcmil
190	208	380	#4 - 500 kcmil	380	#4 - 500 kcmil	400	(2) 3/0 - 500 kcmil	400	(2) 3/0 - 500 kcmil
	230	380	#4 - 500 kcmil	380	#4 - 500 kcmil	400	(2) 3/0 - 500 kcmil	400	(2) 3/0 - 500 kcmil
	460	175	#14 - 2/0	175	#14 - 2/0	250	#6 - 350 kcmil	250	#6 - 350 kcmil
	575	175	#14 - 2/0	175	#14 - 2/0	250	#6 - 350 kcmil	250	#6 - 350 kcmil

Field Wiring

The TGZ units are supplied standard with compressor contactors and power terminal block, designed for multi-point power supply to the unit, no compressor circuit breakers. Available options are:

- Single-point connection to power block with compressor circuit breakers
- Single-point connection to disconnect switch with compressor circuit breakers
- High short circuit current rating with single-point disconnect switch
- Multi-point connection to disconnect switch, no compressor circuit breakers

A factory-installed control transformer is standard. Optionally, a field-installed control power source can be wired to the unit.

Wiring and conduit selections must comply with the National Electrical Code and/or local requirements.

Unit power inlet wiring must enter the control box through the right side. A 7/8-inch pilot knockout is provided. (Refer to the unit dimension drawings beginning on page 51 for the location of power (and control) connections.)

CAUTION

To avoid equipment damage, use only copper conductors in main terminal block.

Figure 18, TGZ Field Wiring Diagram

FIELD WIRING DIAGRAM WITH MICROTECH CONTROLLER WITH PACKAGE UNIT WITH WATER COOLED CONDENSER

NOTE: ALL FIELD
WIRING TO BE
INSTALLED AS NEC
CLASS 1
WIRING SYSTEM WITH
CONDUCTOR
RATED 600 VOLTS.

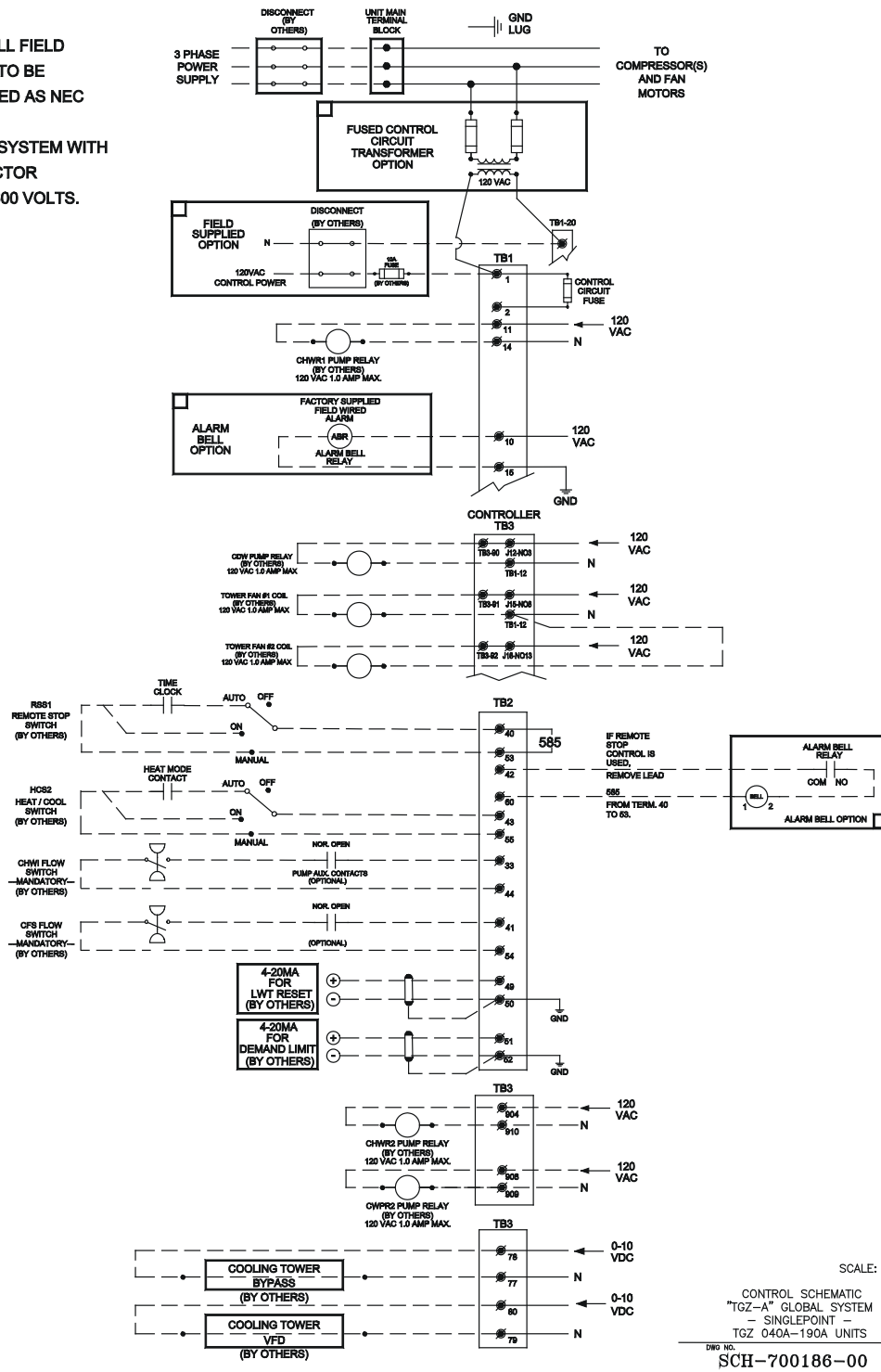

TSC Electrical Data

Figure 19, TSC Field Wiring Diagram

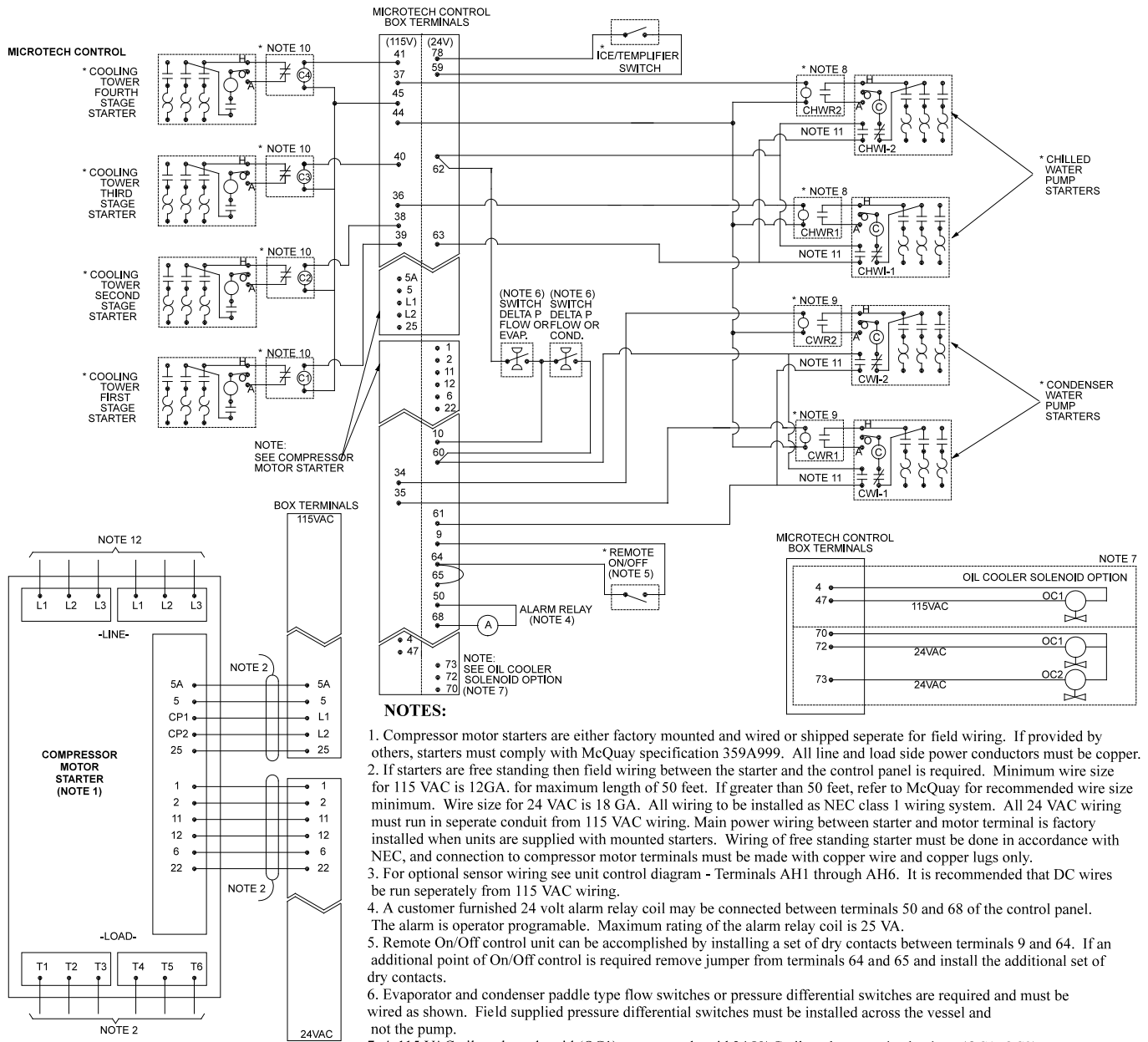

FOR DC VOLTAGE AND 4-20 MA CONNECTIONS (SEE NOTE 3)

FOR DETAILS OF CONTROL REFER TO UNIT CONTROL SCHEMATIC 071853301

* FIELD SUPPLIED ITEM

NOTES:

1. Compressor motor starters are either factory mounted and wired or shipped separate for field wiring. If provided by others, starters must comply with McQuay specification 359A999. All line and load side power conductors must be copper.
2. If starters are free standing then field wiring between the starter and the control panel is required. Minimum wire size for 115 VAC is 12GA. for maximum length of 50 feet. If greater than 50 feet, refer to McQuay for recommended wire size minimum. Wire size for 24 VAC is 18 GA. All wiring to be installed as NEC class 1 wiring system. All 24 VAC wiring must run in separate conduit from 115 VAC wiring. Main power wiring between starter and motor terminal is factory installed when units are supplied with mounted starters. Wiring of free standing starter must be done in accordance with NEC, and connection to compressor motor terminals must be made with copper wire and copper lugs only.
3. For optional sensor wiring see unit control diagram - Terminals AH1 through AH6. It is recommended that DC wires be run separately from 115 VAC wiring.
4. A customer furnished 24 volt alarm relay coil may be connected between terminals 50 and 68 of the control panel. The alarm is operator programable. Maximum rating of the alarm relay coil is 25 VA.
5. Remote On/Off control unit can be accomplished by installing a set of dry contacts between terminals 9 and 64. If an additional point of On/Off control is required remove jumper from terminals 64 and 65 and install the additional set of dry contacts.
6. Evaporator and condenser paddle type flow switches or pressure differential switches are required and must be wired as shown. Field supplied pressure differential switches must be installed across the vessel and not the pump.
7. A 115 VAC oil cooler solenoid (OC1) or a two solenoid 24 VAC oil cooler motorized valve. (OC1, OC2) are two options required on some models. Refer to the installation manual and wire as shown.
8. Optional customer supplied 115 VAC 25VA maximum coil rated chilled water pump relay (CHWR 1 and 2) may be wired as shown. This option will cycle the chilled water pump in response to building load.
9. The condenser water pump must cycle with the unit. A customer supplied 115VAC 25VA maximum coil rated condenser water pump relay (CWR 1 and 2) is to be wired as shown.
10. Optional customer supplied 115 VAC 25 VA maximum coil rated cooling tower fan relays (C1 - C4) may be wired as shown. This option will cycle the cooling tower fans in order to maintain unit head pressure.
11. Auxilliary 24 VAC rated contacts in both the chilled water and condenser water pump starters must be wired as shown.
12. Incoming power lugs on the McQuay self-manufactured starter are sized for 2 4/0 (0000) cables per phase. Six main power leads are required if A. The three wire conductor size exceeds 4/0 (0000) or B. The RLA of the compressor exceeds 184 amps.
13. All wiring to be NEC Class 1

TSC Motor Starters

McQuay has a wide variety of centrifugal compressor starter types and options to fit virtually all applications. The specifics of the final selection of size, enclosure, and options are covered in the catalog *Cat Starters-6* (or later). Please consult the local McQuay sales office or the starter catalog for starter details. This section contains a general overview only.

Mounting Options, Low Voltage, 200 to 600 Volts

Factory-mounted; starters furnished, mounted and wired in the factory. Due to shipping width limitations, the starters for TSC 100 through 126 are shipped loose with cable kits and mounting brackets for field installation on the unit by others.

Freestanding; furnished by McQuay and drop shipped to the job site for setting and wiring by others.

Starters by others; starters furnished by others must meet McQuay Specification R35999901, available from the local McQuay sales office. The starters are furnished and installed by others.

Table 19, Low Voltage Starter Mounting Arrangements

Size	Factory-Mounted	Free-Standing	Brackets & Cables
TSC 063-087	X	X	
TSC 100-126		X	X

Mounting Options, Medium Voltage, 2300 to 6000 Volts

All starter types in these voltages are for field setting and wiring only.

Starter Types

Solid state starters are available for both low and medium voltages and are similar in construction and features regardless of voltage.

For low voltage application, Wye-Delta Closed Transition starters are available, in addition to solid state.

For medium voltage application, autotransformer, primary reactor reduced voltage and across-the-line starters are offered in addition to solid state.

Physical Data

TGZ Scroll

Table 20, TGZ 040A - 060A

TGZ Unit Model	TGZ 040A		TGZ 050A		TGZ 060A	
No. Of Circuits	2		2		2	
COMPRESSORS						
Nominal Horsepower	10	10	13	13	15	15
Number per Circuit	2	2	2	2	2	2
Unloading Steps, %	25 / 50 / 75 / 100		25 / 50 / 75 / 100		25 / 50 / 75 / 100	
Oil Charge, per compr. oz (l)	110 (3.3)		110 (3.3)		110 (3.3)	
CONDENSER						
Number	1		1		1	
No. Refrigerant Circuits	2		2		2	
Diameter, in. (mm)	10.75 (273)		10.75 (273)		10.75 (273)	
Tube Length, in (mm)	122 (3099)		122 (3099)		122 (3099)	
Design W.P.,psig (kPa):						
Refrigerant Side	500 (3447)		500 (3447)		500 (3447)	
Water Side	232 (1599)		232 (1599)		232 (1599)	
Relief Valve Setting, psig (kPa)	500 (3447)		500 (3447)		500 (3447)	
No. Of Water Passes - Standard	4		4		4	
No. Of Water Passes - Optional	2		2		2	
Water Volume, gallons (l)	13.6 (51.5)		13.6 (51.5)		16.3 (61.8)	
Pump-Down Capacity lb., (kg)	121.7 (55.2)	121.7 (55.2)	121.7 (55.2)	121.7 (55.2)	107.3 (48.7)	107.3 (48.7)
Connections:						
Water In & Out, in., (mm) (4 Pass)	3 (76)		3 (76)		3 (76)	
Water In & Out, in., (mm) (2 Pass)	4 (102)		4 (102)		4 (102)	
Relief Valve, Flare in., (mm)	5/8 (15.9)		5/8 (15.9)		5/8 (15.9)	
Purge Valve, Flare in., (mm)	5/8 (15.9)		5/8 (15.9)		5/8 (15.9)	
Vent & Drain, in (mm) FPT	1/2 (12.7)		1/2 (12.7)		1/2 (12.7)	
Liquid Subcooling	Integral		Integral		Integral	
EVAPORATOR, BRAZED-PLATE						
Number	1		1		1	
No. Refrigerant Circuits	2		2		2	
Water Volume, gallons (l)	3.7 (14.0)		5.0 (18.9)		5.0 (18.9)	
Refrigerant Side D.W.P., psig, (kPa)	450 (3102)		450 (3102)		450 (3102)	
Relief Valve Setting, psig (kPa)	450 (3102)		450 (3102)		450 (3102)	
Water Side D.W.P., psig, (kPa)	450 (3102)		450 (3102)		450 (3102)	
Water Connections:						
In & Out, in. (mm) victaulic	3 (76)		3 (76)		3 (76)	
Drain & Vent	Field Supplied		Field Supplied		Field Supplied	
UNIT DIMENSIONS						
Length, in. (mm)	139 (3530)		139 (3530)		139 (3530)	
Width, in. (mm)	33 (838)		33 (838)		33 (838)	
Height, in. (mm)	63.2 (1605)		63.2 (1605)		63.2 (1605)	
UNIT WEIGHTS						
Operating WT., lb., (kg)	2604 (1181)		2644 (1199)		2699 (1224)	
Shipping WT., lb. (kg)	2434 (1104)		2464 (1117)		2496 (1132)	
R-134a Ref. Charge, lb. (kg)	45 (20.4)	45 (20.4)	45 (20.4)	45 (20.4)	50 (22.7)	50 (22.7)

Table 21, TGZ 080A – 100A

TGZ Unit Model	TGZ 080A		TGZ 100A	
No. Of Circuits	2		2	
COMPRESSORS				
Nominal Horsepower	20	20	25	25
Number per Circuit	2	2	2	2
Staging Steps, %	25 / 50 / 75 / 100		25 / 50 / 75 / 100	
Oil Charge, per compressor. oz (l)	158 (4.7)		200 (5.9)	
CONDENSER				
Number	1		1	
No. Refrigerant Circuits	2		2	
Diameter, in. (mm)	14 (356)		14 (356)	
Tube Length, in (mm)	122 (3099)		122 (3099)	
Design W.P.,psig (kPa):				
Refrigerant Side	500 (3447)		500 (3447)	
Water Side	232 (1599)		232 (1599)	
Relief Valve Setting, psig (kPa)	500 (3447)		500 (3447)	
No. Of Water Passes - Standard	4		4	
No. Of Water Passes - Optional	2		2	
Water Volume, gallons (l)	27.5 (104)		27.5 (104)	
Pump-Down Capacity lb., (kg)	186 (84)	186 (84)	186 (84)	186 (84)
Connections:				
Water In & Out, in., (mm) (4 Pass)	4 (102)		4 (102)	
Water In & Out, in., (mm) (2 Pass)	4 (102)		4 (102)	
Relief Valve, Flare in., (mm)	5/8 (15.9)		5/8 (15.9)	
Purge Valve, Flare in., (mm)	5/8 (15.9)		5/8 (15.9)	
Vent & Drain, in (mm) FPT	1/2 (12.7)		1/2 (12.7)	
Liquid Subcooling	Intergral		Intergral	
EVAPORATOR, BRAZED PLATE				
Number	1		1	
No. Refrigerant Circuits	2		2	
Water Volume, gallons (l)	8.7 (32.9)		8.7 (32.9)	
Refrigerant Side D.W.P., psig, (kPa)	450 (3102)		450 (3102)	
Relief Valve Setting, psig (kPa)	450 (3102)		450 (3102)	
Water Side D.W.P., psig, (kPa)	450 (3102)		450 (3102)	
Water Connections:				
In & Out, in. (mm) victaulic	3 (76)		3 (76)	
Drain & Vent	Field Supplied		Field Supplied	
UNIT DIMENSIONS				
Length, in. (mm)	153 (3886)		153 (3886)	
Width, in. (mm)	32.5 (826)		32.5 (826)	
Height, in. (mm)	65.5 (1664)		65.5 (1664)	
UNIT WEIGHTS				
Operating WT., lb., (kg)	4422 (2005)		4749 (2154)	
Shipping WT., lb. (kg)	4116 (1867)		4418 (2004)	
R-134a Ref. Charge, lb. (kg)	85 (38.6)	85 (38.6)	90 (40.8)	90 (40.8)

Table 22, TGZ 110A – 120A

TGZ Unit Model	TGZ 110A		TGZ 120A	
No. Of Circuits	2		2	
COMPRESSORS				
Nominal Horsepower	25	30	30	30
Number per Circuit	2	2	2	2
Staging, 4 Stages, Circuit #1 in Lead	23 / 50 / 73 / 100		25 / 50 / 75 / 100	
Staging, 4 Stages, Circuit #2 in Lead	27 / 50 / 77 / 100		25 / 50 / 75 / 100	
Oil Charge, per compressor. oz (l)	200 (5.9)	213 (6.3)	213 (6.3)	
CONDENSER				
Number	1		1	
No. Refrigerant Circuits	2		2	
Diameter, in. (mm)	16.0 (406.4)		16.0 (406.4)	
Tube Length, in (mm)	120 (3048)		120 (3048)	
Design W.P.,psig (kPa):				
Refrigerant Side	500 (3447)		500 (3447)	
Water Side	232 (1599)		232 (1599)	
Relief Valve Setting, psig (kPa)	500 (3447)		500 (3447)	
No. Of Water Passes - Standard	4		4	
No. Of Water Passes - Optional	2		2	
Water Volume, gallons (l)	35.4 (134)		35.4 (134)	
Pump-Down Refrig Capacity, lb., (kg)	252 (114)	252 (114)	252 (114)	252 (114)
Connections:				
Water In & Out, in., (mm) (4 Pass)	4 (102)		4 (102)	
Water In & Out, in., (mm) (2 Pass)	5 (127)		5 (127)	
Relief Valve, Flare in., (mm)	5/8 (15.9)		5/8 (15.9)	
Purge Valve, Flare in., (mm)	5/8 (15.9)		5/8 (15.9)	
Vent & Drain, in (mm) FPT	1/2 (12.7)		1/2 (12.7)	
Liquid Subcooling	Integral		Integral	
EVAPORATOR, BRAZED-PLATE				
Number	1		1	
No. Refrigerant Circuits	2		2	
Water Volume, gallons (l)	9.7 (36.7)		9.7 (36.7)	
Refrigerant Side D.W.P., psig, (kPa)	450 (3102)		450 (3102)	
Relief Valve Setting, psig (kPa)	450 (3102)		450 (3102)	
Water Side D.W.P., psig, (kPa)	450 (3102)		450 (3102)	
Water Connections:				
In & Out, in. (mm) victaulic	3 (76)		3 (76)	
Drain & Vent	Field Supplied		Field Supplied	
UNIT DIMENSIONS				
Length, in. (mm)	153 (3886)		153 (3886)	
Width, in. (mm)	34.5 (876)		34.5 (876)	
Height, in. (mm)	67 (1702)		67 (1702)	
UNIT WEIGHTS				
Operating WT., lb., (kg)	5373 (2437)		5319 (2412)	
Shipping WT., lb. (kg)	4967 (2253)		4913 (2228)	
R-134a Ref. Charge, lb. (kg)	110 (49.9)	110 (49.9)	110 (49.9)	110 (49.9)

Table 23, TGZ 150A – 190A

TGZ Unit Model	TGZ 150A		TGZ 170A		TGZ 190A	
No. Of Circuits	2		2		2	
COMPRESSORS						
Nominal Horsepower	25	25	25	30	30	30
Number per Circuit	3	3	3	3	3	3
Staging, 6 Stages, Circuit #1 in Lead	17 / 33 / 50 / 67 / 83 / 100		15 / 33 / 48 / 67 / 81 / 100		17 / 33 / 50 / 67 / 83 / 100	
Staging, 6 Stages, Circuit #2in Lead	17 / 33 / 50 / 67 / 83 / 100		19 / 33 / 52 / 67 / 85 / 100		17 / 33 / 50 / 67 / 83 / 100	
Oil Charge, per compressor. oz (l)	200 (5.9)		200 (5.9)	213 (6.3)	213 (6.3)	
CONDENSER						
Number	1		1		1	
No. Refrigerant Circuits	2		2		2	
Diameter, in. (mm)	16 (406.4)		16 (406.4)		16 (406.4)	
Tube Length, in (mm)	144 (3658)		144 (3658)		144 (3658)	
Design W.P.,psig (kPa):						
Refrigerant Side	500 (3447)		500 (3447)		500 (3447)	
Water Side	232 (1599)		232 (1599)		232 (1599)	
Relief Valve Setting, psig (kPa)	500 (3447)		500 (3447)		500 (3447)	
No. Of Water Passes - Standard	4		4		4	
No. Of Water Passes - Optional	2		2		2	
Water Volume, gallons (l)	42.5 (160.9)		47.1 (178.4)		47.1 (178.4)	
Pump-Down Refrig Capacity, lb., (kg)	302 (137)	302 (137)	277 (126)	277 (126)	277 (126)	277 (126)
Connections:						
Water In & Out, in., (mm) (4 Pass)	4 (102)		4 (102)		4 (102)	
Water In & Out, in., (mm) (2 Pass)	5 (127)		5 (127)		5 (127)	
Relief Valve, Flare in., (mm)	5/8 (15.9)		5/8 (15.9)		5/8 (15.9)	
Purge Valve, Flare in., (mm)	5/8 (15.9)		5/8 (15.9)		5/8 (15.9)	
Vent & Drain, in (mm) FPT	1/2 (12.7)		1/2 (12.7)		1/2 (12.7)	
Liquid Subcooling	Integral		Integral		Integral	
EVAPORATOR, SHELL-and-TUBE						
Number	1		1		1	
No. Refrigerant Circuits	2		2		2	
Water Volume, gallons (l)	57.6 (218)		56.9 (215.4)		56.9 (215.4)	
Refrigerant Side D.W.P., psig, (kPa)	450 (3102)		450 (3102)		450 (3102)	
Water Side D.W.P., psig, (kPa)	150 (1034)		150 (1034)		150 (1034)	
Relief Valve Setting, psig (kPa)	450 (3102)		450 (3102)		450 (3102)	
Water Connections:						
In & Out, in. (mm) victaulic	8 (203)		8 (203)		8 (203)	
Drain & Vent	1/2 (12.7)		1/2 (12.7)		1/2 (12.7)	
UNIT DIMENSIONS						
Length, in. (mm)	174 (4420)		174 (4420)		174 (4420)	
Width, in. (mm)	34 (864)		34 (864)		34 (864)	
Height, in. (mm)	78 (1981)		78 (1981)		78 (1981)	
UNIT WEIGHTS						
Operating WT., lb., (kg)	7877 (3572)		7991 (3624)		7972 (3616)	
Shipping WT., lb. (kg)	7019 (3183)		7101 (3220)		7082 (3212)	
R-134a Refrigerant Charge, lb. (kg)	140 (63.5)	140 (63.5)	150 (68)	150 (68)	150 (68)	150 (68)

TGZ Dimensional Data

Figure 20, Dimensions, TGZ 040A - 060A, Standard 4-pass Condenser

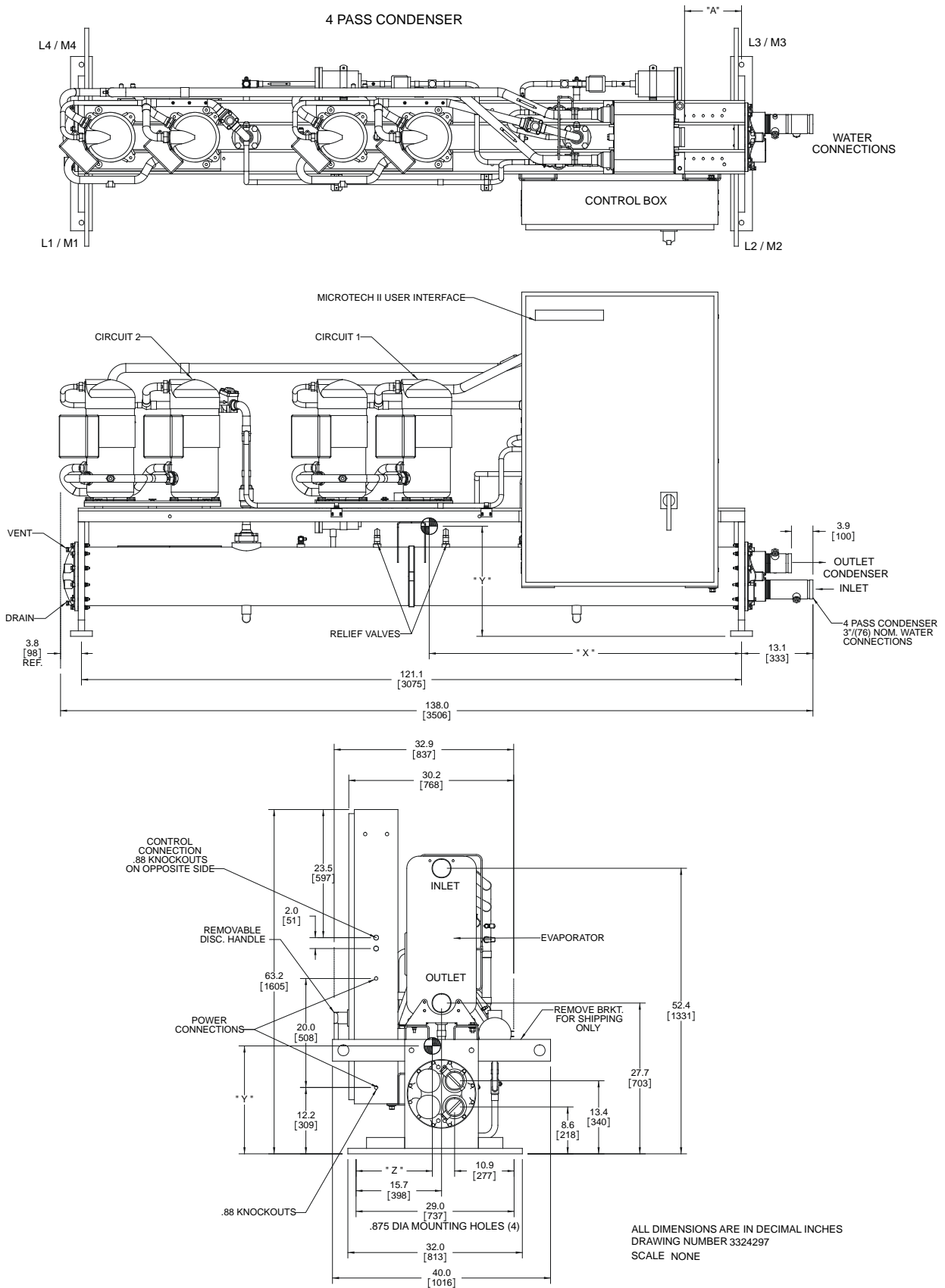

Figure 21, Dimensions, TGZ 040A – 060A, Optional 2-Pass Condenser

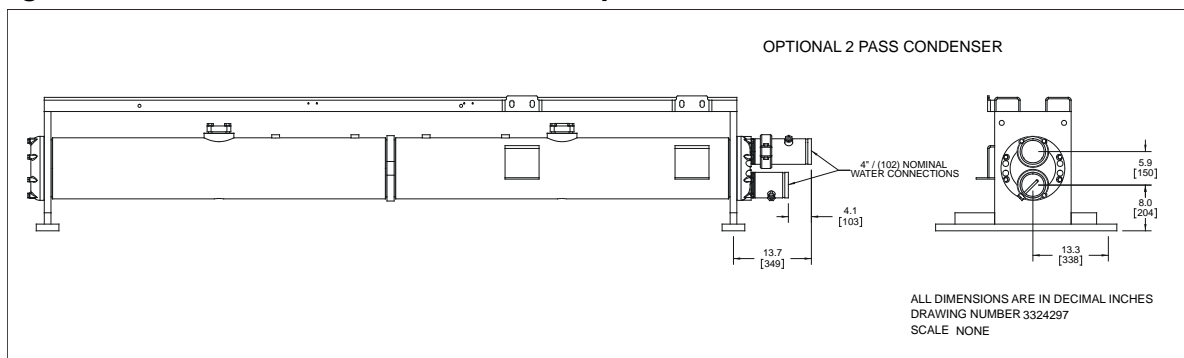

Table 24, 2-Pass and 4-pass Dimensions

TGZ MODEL NUMBER	CHILLER WATER CONNECTION IN(MM) VICTAULIC		CONDENSER WATER CONNECTION IN(MM) VICTAULIC (4 PASS)	CONDENSER WATER CONNECTION IN(MM) VICTAULIC (2 PASS)	CENTER OF GRAVITY		
	SIZE	A	SIZE	SIZE	X	Y	Z
TGZ 040	3 (76)	13.1 (333)	3 (76)	4 (102)	58.3	23.5	14.4
TGZ 050	3 (76)	10.5 (267)	3 (76)	4 (102)	57.4	24.0	14.4
TGZ 060	3 (76)	10.5 (267)	3 (76)	4 (102)	57.5	23.9	14.4

NOTE: Lifting and corner weights are in the "Weights" section on page 59.

Figure 22, Dimensions, TGZ 080A – 100A, Standard 4-Pass Condenser

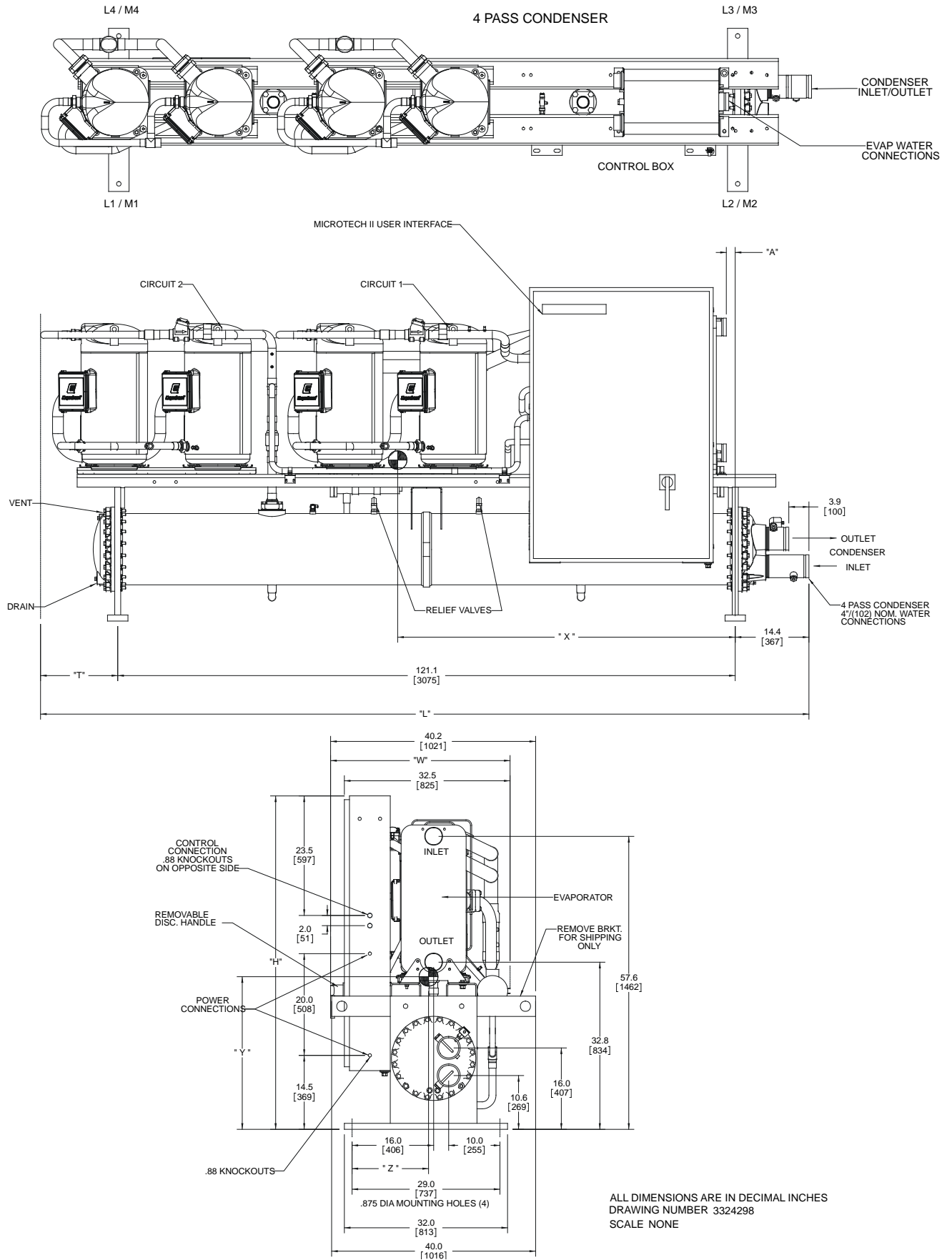
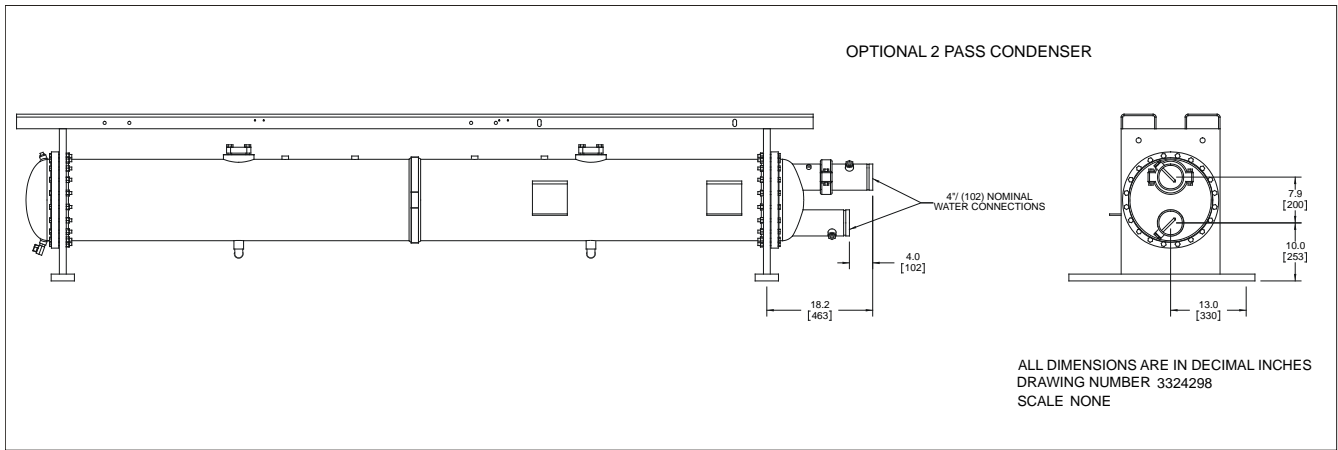

Figure 23, Dimensions, TGZ 080A - 100A, Optional 2-Pass Condenser



NOTE: Lifting and corner weights are in the “Weights” section on page 59.

Table 25, 2-Pass and 4-pass Dimensions

TGZ MODEL	CHILLER WATER CONNECTION IN(MM) VICTAULIC		CONDENSER WATER CONNECTION IN(MM) VICTAULIC (4 PASS)	CONDENSER WATER CONNECTION IN(MM) VICTAULIC (2 PASS)	T	CENTER OF GRAVITY		
	SIZE	A	SIZE (NOM)	SIZE (NOM)		X	Y	Z
TGZ 080	3 (76)	1.7 (43)	4 (102)	4 (102)	13.6 (345)	63.2	30.1	15.1
TGZ 100	3 (76)	1.7 (43)	4 (102)	4 (102)	14.4 (366)	65.6	31.3	15.4

Figure 24, Dimensions, TGZ 110 – 120, Standard 4-Pass Condenser

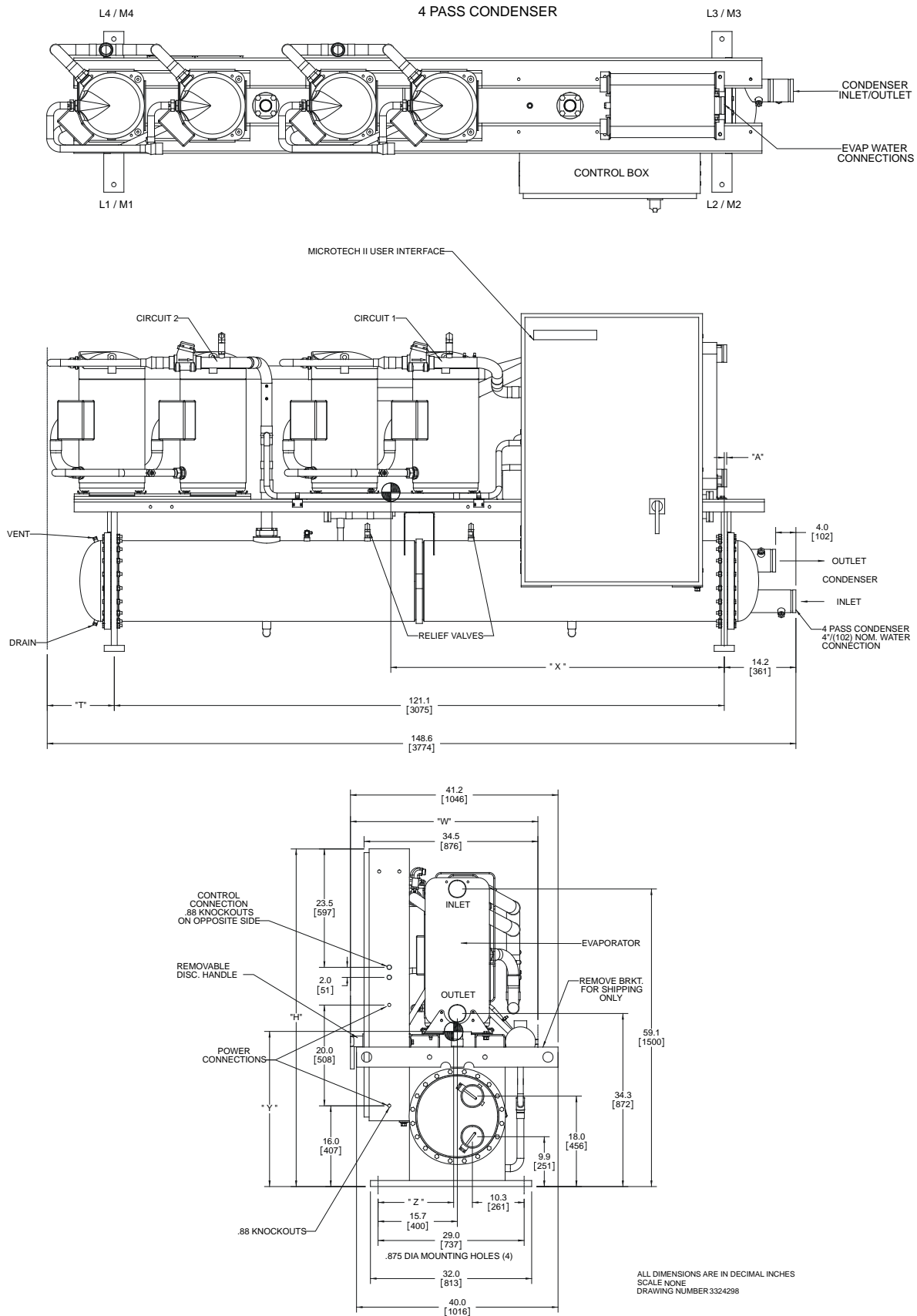
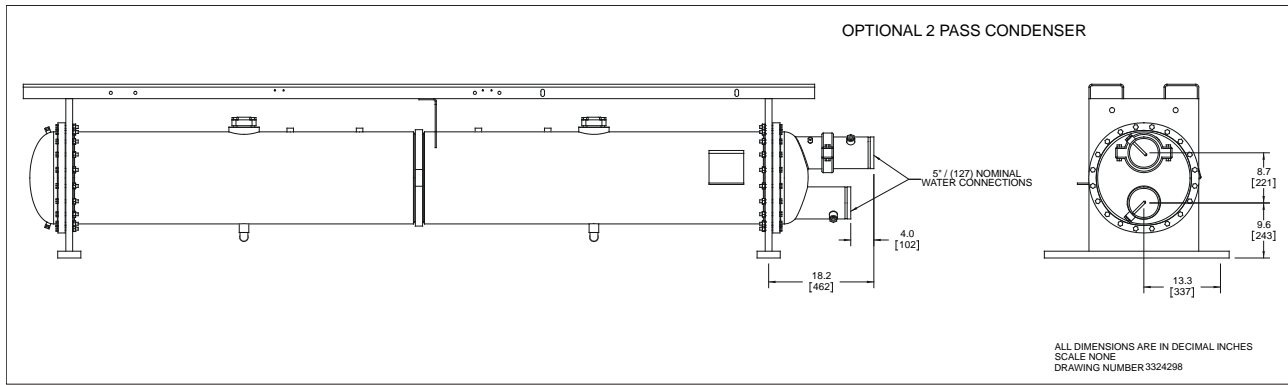

Figure 25, Dimensions, Optional 2-Pass Condenser



NOTE: Lifting and corner weights are in the “Weights” section on page 59.

Table 26, 2-Pass and 4-pass Dimensions

TGZ MODEL	CHILLER WATER CONNECTION IN (MM) VICTAULIC		CONDENSER WATER CONNECTION IN (MM) VICTAULIC (4 PASS)	CONDENSER WATER CONNECTION IN (MM) VICTAULIC (2 PASS)	T	CENTER OF GRAVITY		
	SIZE	A	SIZE	SIZE		X	Y	Z
TGZ 110	3 (76)	0.5 (13)	4 (102)	5 (127)	13.3 (338)	64.3	30.6	15.0
TGZ 120	3 (76)	0.5 (13)	4 (102)	5 (127)	13.3 (338)	64.0	30.1	15.0

Figure 26, Dimensions, TGZ 150A – 190A, Standard 4-Pass Condenser

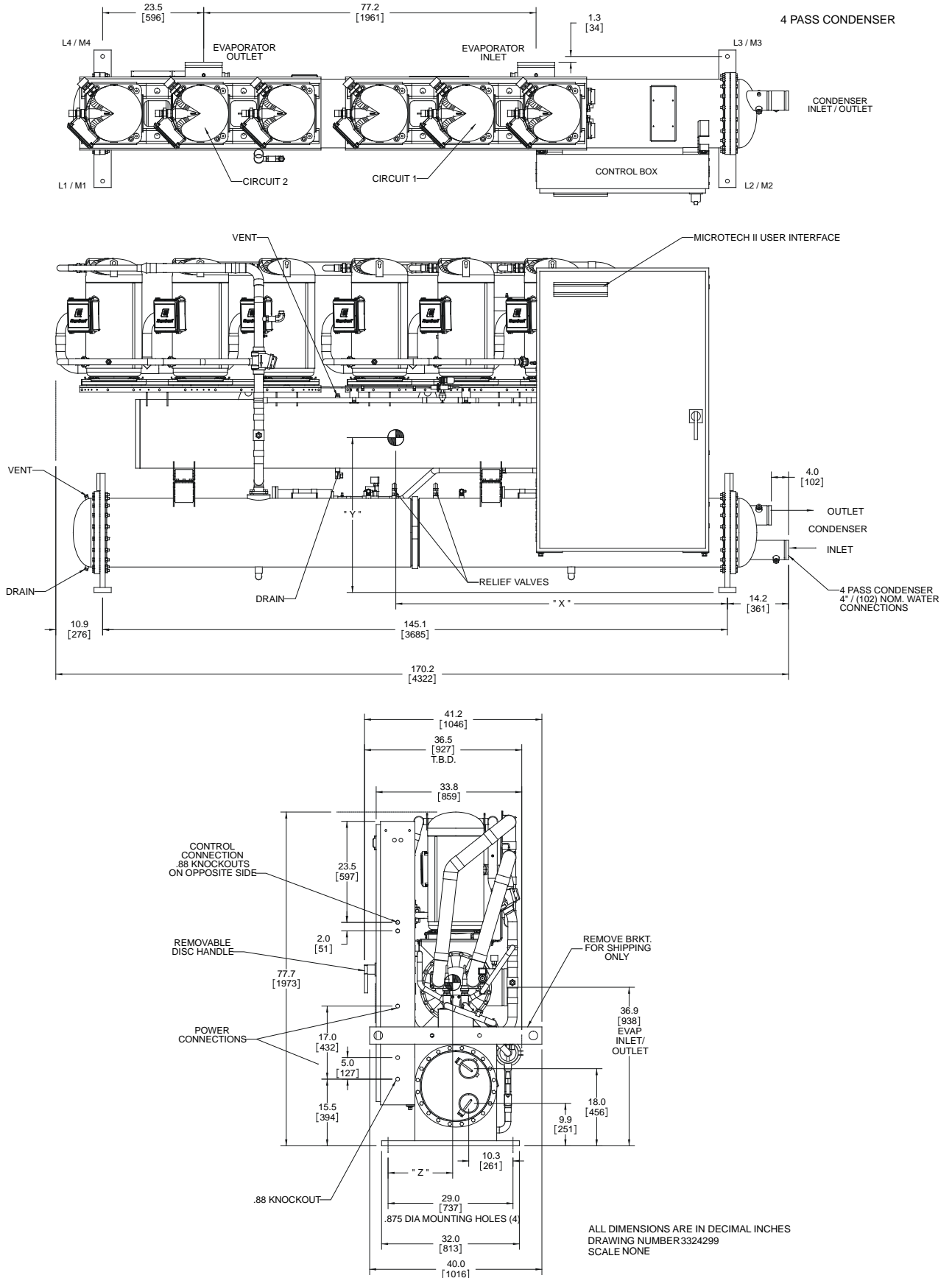
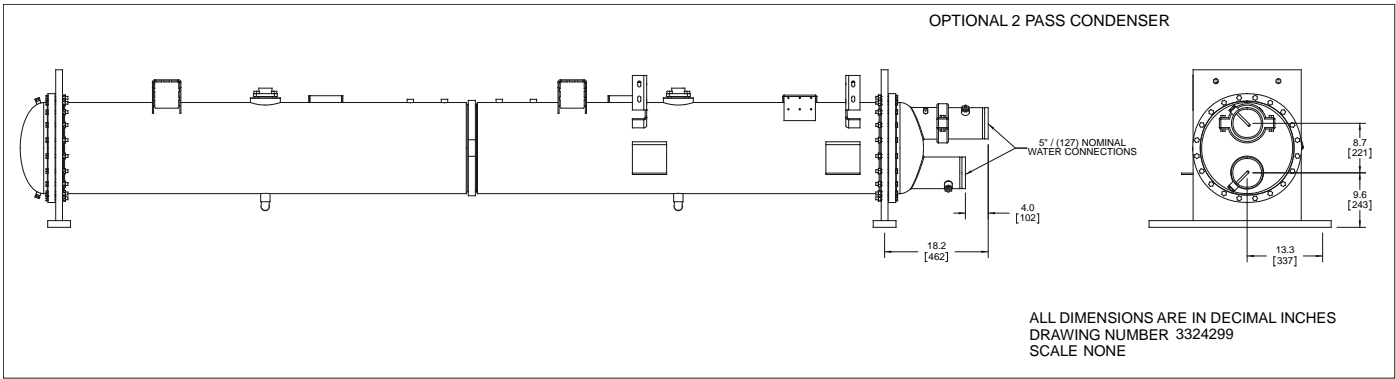

Figure 27, Dimensions, TGZ 150A - 190A, Optional 2-Pass Condenser



NOTE: Lifting and corner weights are in the “Weights” section on page 59.

Table 27, 2-Pass and 4-pass Dimensions

TGZ MODEL	CHILLER WATER CONNECTION IN(MM) VICTAULIC	CONDENSER WATER CONNECTION IN(MM) VICTAULIC (4 PASS)	CONDENSER WATER CONNECTION IN(MM) VICTAULIC (2 PASS)	CENTER OF GRAVITY		
	SIZE	SIZE	SIZE	X	Y	Z
TGZ 150	8 (203)	4 (102)	5 (127)	78.5	36.0	15.1
TGZ 170	8 (203)	4 (102)	5 (127)	78.4	37.3	15.1
TGZ 190	8 (203)	4 (102)	5 (127)	78.5	38.9	15.0

Weights

NOTE: Refer to the unit dimension drawing for lifting and mounting point's physical location.

Table 28, TGZ Lifting, Mounting, and Total Weights, Inch-Lbs Units

MODEL	LIFTING WEIGHT FOR EACH POINT (LBS)				MOUNTING LOADS FOR EACH POINT (LBS)				SHIPPING WEIGHT (LBS)	OPERATING WEIGHT (LBS)
	L1	L2	L3	L4	M1	M2	M3	M4		
TGZ040A	592	638	625	580	633	682	668	620	2434	2604
TGZ050A	590	653	641	580	633	701	688	622	2464	2644
TGZ060A	597	660	650	588	646	714	703	636	2496	2699
TGZ080A	1034	947	1021	1115	1111	1017	1097	1198	4116	4422
TGZ100A	1126	952	1072	1268	1211	1023	1152	1363	4418	4749
TGZ110A	1271	1123	1207	1366	1375	1215	1305	1478	4967	5373
TGZ120A	1257	1122	1195	1339	1361	1214	1294	1450	4913	5319
TGZ150A	1823	1546	1675	1975	2046	1735	1880	2216	7019	7877
TGZ170A	1846	1570	1694	1991	2077	1767	1906	2241	7101	7991
TGZ190A	1848	1566	1682	1986	2081	1763	1894	2235	7082	7972

Table 29, TGZ Lifting, Mounting, and Total Weights, SI Units

MODEL	LIFTING WEIGHT FOR EACH POINT (KG)				MOUNTING LOADS FOR EACH POINT (KG)				SHIPPING WEIGHT (KG)	OPERATING WEIGHT (KG)
	L1	L2	L3	L4	M1	M2	M3	M4		
TGZ040A	269	289	283	263	287	309	303	281	1104	1181
TGZ050A	268	296	291	263	287	318	312	282	1118	1199
TGZ060A	271	299	295	267	293	324	319	288	1132	1224
TGZ080A	469	430	463	506	504	461	498	543	1867	2006
TGZ100A	511	432	486	575	549	464	523	618	2004	2154
TGZ110A	577	509	547	620	624	551	592	670	2253	2437
TGZ120A	570	509	542	607	617	551	587	658	2229	2413
TGZ150A	827	701	760	896	928	787	853	1005	3184	3573
TGZ170A	837	712	768	903	942	802	865	1017	3221	3625
TGZ190A	838	710	763	901	944	800	859	1014	3212	3616

Figure 28, Lifting and Mounting Points Location

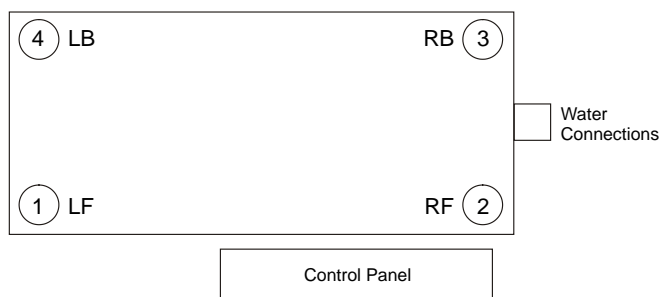

Sound Data

TGZ Sound Data

Table 30, TGZ Sound Power

TGZ Unit Size	Octave Band Sound Power Levels per ARI Standard 575 (dB)								Overall "A" Weighted
	63 Hz	125 Hz	250 Hz	500 Hz	1000 Hz	2000 Hz	4000 Hz	8000 Hz	
040	46	50	61	83	75	80	75	63	86
050	46	49	61	80	73	78	75	63	83
060	46	49	61	80	73	78	75	63	83
080	57	61	72	83	86	85	82	70	90
100	58	62	74	84	88	86	83	72	92
110	58	62	74	84	89	88	83	72	93
120	58	62	75	86	91	90	84	75	95
150	58	62	74	84	88	86	83	72	92
170	58	62	75	85	90	88	84	73	94
190	60	63	75	86	92	91	85	75	96

Note: Sound Power per ARI Standard 575.

Table 31, TGZ Sound Power with Sound Blankets

TGZ Unit Size	Octave Band Sound Power Levels per ARI Standard 575 (dB)								Overall "A" Weighted
	63 Hz	125 Hz	250 Hz	500 Hz	1000 Hz	2000 Hz	4000 Hz	8000 Hz	
040	46	50	58	75	65	73	64	50	78
050	46	49	58	72	64	73	64	49	76
060	46	49	58	72	64	73	64	49	76
080	57	61	68	79	78	77	74	63	84
100	58	62	70	80	81	80	75	65	86
110	58	62	71	82	82	81	75	67	87
120	58	62	72	83	83	84	77	68	89
150	58	62	70	80	81	80	75	65	86
170	58	62	72	81	83	83	77	67	88
190	60	63	74	83	86	86	80	70	91

Table 32, TGZ Sound Pressure

TGZ Unit Size	Octave Band Sound Pressure Levels per ARI Standard 575 (dB)								Overall "A" Weighted
	63 Hz	125 Hz	250 Hz	500 Hz	1000 Hz	2000 Hz	4000 Hz	8000 Hz	
040	38	42	53	75	67	72	67	55	78
050	38	41	53	72	65	70	66	55	75
060	38	41	53	72	65	70	66	55	75
080	49	53	64	75	78	77	73	62	82
100	50	54	66	76	80	78	75	64	84
110	50	54	66	76	81	80	75	64	85
120	50	54	67	78	83	82	76	67	87
150	50	54	66	76	80	78	75	64	84
170	50	54	67	77	82	80	76	65	86
190	52	55	67	78	84	83	77	67	88

Note: Distance from the unit is one meter.

Table 33, TGZ Sound Pressure with Sound Blankets

TGZ Unit Size	Octave Band Sound Pressure Levels per ARI Standard 575 (dB)								Overall "A" Weighted
	63 Hz	125 Hz	250 Hz	500 Hz	1000 Hz	2000 Hz	4000 Hz	8000 Hz	
040	38	42	50	67	57	65	56	42	70
050	38	41	50	64	56	65	56	41	68
060	38	41	50	64	56	65	56	41	68
080	49	53	60	71	70	69	66	55	76
100	50	54	62	72	73	72	67	57	78
110	50	54	63	74	74	73	67	59	79
120	50	54	64	75	75	76	69	60	81
150	50	54	62	72	73	72	67	57	78
170	50	54	64	73	75	75	69	59	80
190	52	55	66	75	78	78	72	62	83

Note: Distance from the unit is one meter.

Test Data

Sound testing is performed in accordance with ARI Standard 575. Values are taken at one meter from the unit and with the units fully loaded. Values are mid-band. Octave band readings are flat dBa, overall are "A" weighted.

Sound Reduction

Sound blankets are available as an option on all size TGZ units. One blanket is supplied for each compressor. The blankets are secured with Velcro straps for a tight fit. They can be ordered with the unit and factory installed or ordered after shipment for field installation. They are easily removed for service and inspection purposes.

Options

TGZ Scroll Templifier

Controls/Instrumentation

Water Flow Switch

Factory-installed evaporator and condenser water flow switches in the water piping to safeguard the unit from flow interruptions. Installation of water flow switches is mandatory and they must be installed in the field if the factory option is not ordered.

Remote Interface Panel

A remote interface panel, field wired to the unit, providing all the data viewable on the unit's controller, including alarm clearing and setpoint change capability.

BAS Interface

McQuay's Open Choice feature consists of a factory-installed communication module for LONMARK®, Modbus®, or BACnet® with MSTP or Ethernet.

Electrical

Power Connections

TGZ chillers are supplied as standard with compressor contractors and power block, designed for multi-point power supply to the unit, no compressor circuit breakers. Available options are:

- Single-point power connection to power block with compressor circuit breakers
- Single-point power connection to disconnect switch with compressor circuit breakers
- Multi-point power connection to disconnect switches, no compressor circuit breakers
- High short circuit current rating with single-point disconnect switch. See page 39 for ratings. Not available on TGZ 190 at 208/230V with supplementary overloads or TGZ 150 to 190 at 208/230V without supplementary overloads.

Phase and Under/Over Voltage Protection

Factory-installed option giving phase loss with under/over voltage protection with LED indication of fault type.

Ground Fault Protection

Protects equipment from damage from low-level line-to-ground fault currents, less than those required for conductor protection, and quickly shuts off power.

Supplementary Overloads

The supplemental overloads option is used to reduce the required electrical service size and wire sizing to the water-cooled version of TGZ chillers. The overload option is only available for models with single-point electrical power connections.

Unit

Hot Gas Bypass

Factory mounted hot gas bypass permits unit operation down to approximately 10% of full load capacity and includes a hot gas bypass valve, solenoid valve and manual shutoff valve. Hot gas bypass is provided on both refrigerant circuits.

Vibration Isolators

Spring or rubber-in-shear vibration isolators are available as a kit for field installation to reduce vibration transmission through the unit base.

Acoustical Compressor Wraps

Factory-(or field installed) installed acoustical compressor wraps are available for all units when ultra low sound levels are required. There is one wrap for each compressor and they are easily removed.

Condenser Connections

Left-hand condenser water connections (as viewed looking at the control panel) are optional.

Double Insulation

The evaporator is available with an additional layer of 3/4-inch insulation. This option is recommended for ice or low temperature applications or for high ambient humidity.

Skid

The unit is equipped with a disposable wooden skid to assist in some rigging situations. The skid option is strongly recommended for ease of handling and to help prevent damage if a crane is not available for rigging at site.

Paint

As standard, the compressors have the manufacturer's black paint and insulation and piping is unpainted. As an option, the entire unit can be painted with McQuay beige paint.

TSC Centrifugal Templifiers

Vessels

Marine Water Boxes

Provides tube access for inspection, cleaning, and removal without dismantling water piping.

Flanges (Victaulic standard)

ANSI raised face flanges on either the evaporator or condenser. Mating flanges are by others.

0.028 or 0.035 in. Tube Wall Thickness

For applications with aggressive water conditions requiring thicker tube walls.

Cupro-nickel or Titanium Tube Material

For use with corrosive water conditions, only available with clad tube sheets.

Water Side Vessel Construction of 300 psi (150 psi is Standard)

For high pressure water systems, typically high-rise building construction.

Water Flow or Differential Pressure Switches

A proof of flow device is mandatory in the water system. They can be field supplied, mounted and wired. This option provides them as a factory mounted and wired option.

Controls

English or Metric Display

Either English or metric units for operator ease of use.

BAS Interface Module for the Applicable Protocol Being Used.

Electrical

Optional Starters for Factory or Field Mounting

See details in the Motor Starter section on page 46 of this manual.

NEMA 4 Watertight Enclosure

For use where there is a possibility of water intrusion into the control panel.

NEMA 12 Dust-tight Enclosure

For use in dusty areas.

Unit

Export Packaging

Can be either slat or full crate for additional protection during shipment. Units normally shipped in containers.

Pumpout Unit

Available in 1100 to 4900 pound sizes.

Refrigerant Monitor

For remote mounting including accessories such as 4-20ma signal, strobe light, audible horn, air pick-up filter.

Sound Attenuation Package

Consists of acoustical insulation on the discharge line.

Extended Warranties

Extended 1, 2, 3, or 4 year warranties for parts only or for parts and labor are available for the entire unit or compressor/motor only.

Guide Specifications

Scroll Compressor Heat Recovery Water Heater

TGZ Scroll

PART 1 - GENERAL

1.01 SUMMARY

Section includes design, performance criteria, refrigerants, controls, and installation requirements for water-cooled scroll compressor packaged chillers.

1.02 REFERENCES

Comply with applicable Standards/Codes of ARI 550/590-98, ANSI/ASHRAE 15, ASME Section VIII, NEC, and OSHA as adopted by the State.

1.03 SUBMITTALS

- A. Submit shop drawings and product data in accordance with contract specifications.
- B. Submittals shall include the following:
 - 1. Dimensioned plan and elevation view drawings, required clearances, and location of all field connections.
 - 2. Summary of all auxiliary utility requirements such as: electricity, water, etc. Summary shall indicate quality and quantity of each required utility.
 - 3. Single-line schematic drawing of the power field hookup requirements, indicating all items that are furnished.
 - 4. Schematic diagram of control system indicating points for field connection. Diagram shall fully delineate field and factory wiring.
 - 5. Installation manual.

1.04 QUALITY ASSURANCE

- A. Qualifications: Equipment manufacturer must specialize in the manufacture of the products specified and have five years experience with similar equipment and the refrigerant offered.
- B. Regulatory Requirements: Comply with the codes and standards specified.
- C. Chiller manufacturer's facility must be ISO registered.

1.05 DELIVERY AND HANDLING

- A. Units shall be delivered to the job site completely assembled and charged with refrigerant and oil by the manufacturer.
- B. Comply with the manufacturer's instructions for rigging and handling equipment.

1.06 WARRANTY

The equipment manufacturer’s warranty shall be for a period of one year from date of equipment start-up but not more than 18 months from shipment. The warranty shall cover defective material and workmanship within the above period, excluding refrigerant.

PART 2--PRODUCTS

2.01 ACCEPTABLE MANUFACTURERS

- A. McQuay International
- B. (Approved Equal)

2.02 UNIT DESCRIPTION

Provide and install as shown on the plans factory assembled, factory charged, and factory run-tested, scroll compressor water heater in the quantity specified. Each chiller shall consist of multiple hermetic scroll compressors, multi-circuit brazed plate or shell-and-tube evaporator, shell-and-tube hot water heater, control system and all components necessary for controlled unit operation. Refrigerant shall be R-134a.

2.03 DESIGN REQUIREMENTS

- A. General: Provide a complete scroll compressor water heater as specified herein and as shown on the drawings. The unit shall be in accordance with the standards referenced in section 1.02 and any local codes in effect.
- B. Performance: Refer to the schedule of performance on the drawings. Performance shall be in accordance with applicable ARI Standard.
- C. Acoustics: Sound pressure levels for the unit shall not exceed the following specified levels. The manufacturer shall provide the necessary sound treatment to meet these levels if required. Sound data shall be provided with the quotation. Test shall be in accordance with ARI Standard 575.

Octave Band

	63	125	250	500	1000	2000	4000	8000	dBA
	_____	_____	_____	_____	_____	_____	_____	_____	_____

2.04 UNIT COMPONENTS

- A. Compressors: The compressors shall be hermetic, scroll type with oil heater and suction strainer. The compressor motor shall be refrigerant gas cooled, high torque, hermetic induction type, two-pole, with inherent thermal protection on all three phases and shall be mounted on RIS vibration isolator pads.
- B. Evaporator: On Models TGZ 040 through 120, the evaporator shall be direct expansion type with stainless steel plates brazed together with copper. It shall be insulated with 3/4 inch (19mm) closed cell polyurethane insulation and have 653 psi (4500 kPa) water side working pressure. A 40-mesh strainer must be installed in the chiller inlet piping

On Models TGZ 150 through 190, the evaporator shall be shell-and-tube

construction, insulated with 3/4 inch (19mm) closed cell polyurethane insulation, and with 150 psi (1033kPa) water-side working pressure.

- C. Condenser: Horizontal shell-and-tube type with steel shell and integral finned copper tubes rolled into steel tube sheets. Construct condenser in accordance with the requirements of ASME Section VIII Unfired Pressure Vessel Code and ANSI B9.1 Safety Code. It shall be designed for 232 psi (1599 kPa) water side working pressure and 500 psig (3445 kPa) refrigerant side pressure and be provided with 500 psig (3445 kPa) ASME, ANSI B9.1 pressure relief valves. It shall be insulated with 3/4 inch (19mm) closed cell polyurethane insulation.
- D. Refrigerant Circuit: Each refrigerant circuit shall include a liquid line shutoff valve, replaceable core or sealed filter-drier, sight glass with moisture indicator, liquid line solenoid valve, expansion valve, and insulated suction line.
- E. Controls:
The unit shall be capable of operating as a heat-recovery water heater or as a water-cooled chiller. Changeover shall be by a panel-mounted Heat/Cool switch or by a remote, digital input signal.

When in the heating mode, unit capacity shall be controlled by a temperature sensor in the leaving condenser (hot) water. Reset of leaving water temperature based on condenser Delta-T shall be provided. This control strategy shall hold the entering water temperature approximately constant and lower the leaving water temperature proportionally to the heating load.

When in the cooling mode, unit capacity shall be controlled by the leaving evaporator water temperature. Reset shall be available based on the return temperature or a 4-20ma external signal.

Control Panel:

The control panel shall contain a microprocessor controller providing operating and equipment protection controls, plus motor starting equipment, factory wired, operationally tested, and ready for operation. Standard components shall include a control transformer with primary and secondary fusing, microprocessor transformers with integral fusing, compressor contactors, circuit breakers, single-point wiring arrangement and switches for each circuit pumpdown and unit control power. The control panel shall have a hinged tool-locked door.

Equipment protection devices controlled by the microprocessor include motor protection, high pressure, loss of refrigerant, loss of water flow, freeze protection, and low refrigerant pressure. Controls shall include auto/stop switch, chilled water setpoint adjustment, anti-recycle timer, and digital display with water temperature and setpoint, operating temperatures and pressures, and diagnostic messages. The following features and functions shall be included:

1. The LCD-type display shall have a minimum of 20 characters with all messages in plain English. Coded messages are not acceptable.
2. Critical parameters shall have their own section of control and shall be password protected.
3. Resetting chilled water temperature by a remote 4-20mA DC signal.
4. Auto restart after a power failure, not requiring external battery backup or auxiliary power for maintaining program memory.

5. Shutdowns shall be date and time stamped. A minimum of six previous occurrences shall be kept in a revolving memory.
6. Start-to-start and stop-to-start timers to provide minimum compressor off-time with maximum motor protection.
7. Compressor lead/lag manually or automatically by compressor number of starts.
8. Continuous diagnostic checks of unit to provide a pre-alarm signal in advance of a shutdown allowing time for remedial action to be taken.
9. The controller shall contain the following features as a minimum:

Equipment Protection

The unit shall be protected in two ways: (1) by alarms that shut the unit down and require manual reset to restore unit operation and (2) by limit alarms that reduce unit operation in response to some out-of-limit condition. Shut down alarms shall activate an alarm signal.

Shutdown Alarms

- No evaporator water flow
- Low evaporator pressure
- High condenser pressure
- Motor protection system
- Phase voltage protection (Optional)
- Evaporator freeze protection
- Sensor failures

Limit Alarms

- Condenser pressure stage down, unloads unit at high discharge pressures
- Low evaporator pressure hold, holds stage #1 until pressure rises
- Low evaporator pressure unload, shuts off one compressor

Unit Enable Selection

Enables unit operation from local keypad, digital input, or BAS

Unit Mode Selection

Selects heating cooling, cooling w/glycol, or test operation mode

Analog Inputs

Reset of leaving water temperature, 4-20 mA

Digital Inputs

- Unit off switch
- Remote start/stop
- Heat-Cool Mode
- Flow switch
- Motor protection

Digital Outputs

- Shutdown alarm; field wired, activates on an alarm condition, off when alarm is cleared
- Evaporator pump; field wired, starts pump when unit is set to start

Optional Building Automation System (BAS) Interface

The unit shall be equipped with an optional factory-installed BAS communication module

Factory mounted DDC controller(s) shall support communication on a BACnet®, Modbus® or LONMARKS ® network via one of the data link / physical layers listed below as specified by the successful Building Automation System (BAS) supplier.

- BACnet MS/TP master (Clause 9)
- BACnet IP, (Annex J)
- BACnet ISO 8802-3, (Ethernet)
- LONMARK® FTT-10A. The unit controller shall be LONMARK® certified.

The information communicated between the BAS and the factory mounted unit controllers shall include the reading and writing of data to allow unit monitoring, control and alarm notification as specified in the unit sequence of operation and the unit points list.

For chillers communicating over a LONWORKS network, the corresponding LONMARK eXternal Interface File (XIF) shall be provided with the chiller submittal data.

All communication from the chiller unit controller as specified in the points list shall be via standard BACnet objects. Proprietary BACnet objects shall not be allowed. BACnet communications shall conform to the BACnet protocol (ANSI/ASHRAE135-2001). A BACnet Protocol Implementation Conformance Statement (PICS) shall be provided along with the unit submittal.

F. The following options are to be included:

- Hot gas bypass on all circuits.
- Chilled water flow switch to be field mounted in the chilled water line and field wired to terminals in the control panel.
- R-I-S or spring vibration isolators for field installation per plans.
- Disconnect switch, single or multi-point
- High interrupt single-point disconnect switch
- High short circuit current rating with single-point disconnect switch
- Single point power connection
- Phase and under/over voltage protection
- Ground fault protection
- BAS interface module for LONWORKS, Modbus, or BACnet Communication with MSTP or Ethernet
- Double evaporator insulation
- Acoustical compressor blankets
- Supplemental overloads
- Entire unit painted with beige paint
- Shipping skid

PART 3 - EXECUTION

3.01 INSTALLATION

- A. Install in strict accordance with manufacturer's requirements, shop drawings, and Contract Documents.
- B. Adjust and level unit on supports.
- C. Coordinate electrical installation with electrical contractor.
- D. Coordinate controls with control contractor.
- E. Provide all appurtenances required to ensure a fully operational and functional chiller.

3.02 START-UP

- A. Ensure proper charge of refrigerant and oil.
- B. Provide testing, and starting of machine, and instruct the Owner in its proper operation and maintenance.

SECTION 15XXX
CENTRIFUGAL HEAT PUMP WATER HEATER
TSC Centrifugal Templifier

PART 1 — GENERAL

1.1 SUMMARY

Section includes design, performance criteria, refrigerants, controls, and installation requirements for centrifugal heat pump water heaters.

1.2 REFERENCES

Comply with the following codes and standards

Underwriters Laboratory	OSHA as adopted by the State
ANSI/ASHRAE 15	ASME Section VIII

1.3 SUBMITTALS

Submittals shall include the following:

- A. Dimensioned plan and elevation view drawings, including motor starter cabinet, required clearances, and location of all field piping and electrical connections.
- B. Summaries of all auxiliary utility requirements such as: electricity, water, air, etc. Summary shall indicate quality and quantity of each required utility.
- C. Diagram of control system indicating points for field interface and field connection. Diagram shall fully depict field and factory wiring.
- D. Manufacturer's performance data.
- E. Before shipment, submit a certification of satisfactory completion of factory run test signed by a company officer..
- F. Installation and Operating Manuals.

1.4 QUALITY ASSURANCE

- A. Qualifications: Equipment manufacturer must specialize in the manufacture of the products specified and have five years experience with the equipment and refrigerant offered.
- B. Regulatory Requirements: Comply with Section 1.2 in codes and standards
- C. Water heater manufacturer plant shall be ISO Registered.

1.5 DELIVERY AND HANDLING

- A. Units shall be delivered to the job site completely assembled and charged with refrigerant and oil.
- B. Comply with the manufacturer's instructions for rigging and transporting units. Leave protective covers in place until installation.

1.6 WARRANTY

The refrigeration equipment manufacturer's warranty shall be for a period of one year from date of equipment start up or 18 months from shipment whichever occurs first. The warranty shall include parts and labor costs for the repair or replacement of defects in material or workmanship excluding refrigerant.

1.7 MAINTENANCE

Unit maintenance shall be the responsibility of the owner.

PART 2 — PRODUCTS

2.1 ACCEPTABLE MANUFACTURERS

- A. McQuay International
- B. (Approved Equal)

2.2 UNIT DESCRIPTION

Provide and install as shown on the plans a factory assembled, factory charged, and factory run-tested heat pump water heater. Each unit shall be complete with a single-stage hermetic centrifugal compressor with lubrication and control system, (factory mounted starter), evaporator, condenser, refrigerant control device and any other components necessary for a complete and operable package.

2.3 DESIGN REQUIREMENTS

- A. General: Provide a complete heat pump water heater as specified herein. Machine shall be provided according to referenced standards Section 1.2. In general, unit shall consist of a compressor, condenser, evaporator, lubrication system, starter and control system. Unit shall be charged with HCFC-134a refrigerant
- B. Performance: Refer to schedule on the drawings.
- C. Acoustics: Sound pressure levels for the complete unit shall not exceed the following specified levels. Provide the necessary acoustic treatment to the unit as required. Data shall be in dB. Data shall be the highest levels recorded at all load points. Test shall be in accordance with ARI Standard 575.

Octave Band									
63	125	250	500	1000	2000	4000	8000	dBA	
—	—	—	—	—	—	—	—	—	—

2.4 WATER HEATER COMPONENTS

- A. Compressor:
 - 1. Unit shall have a single-stage, hermetic centrifugal compressor. Casing design shall ensure major wearing parts, main bearings, and thrust bearings are accessible for maintenance and replacement. The lubrication system shall protect machine during coast down period resulting from a loss of electrical power.
 - 2. The impeller shall be statically and dynamically balanced. The compressor shall be vibration tested and not exceed a level of 0.14 IPS.
 - 3. Movable inlet guide vanes actuated by an internal oil pressure driven piston shall accomplish unloading. Compressors using an unloading system that requires penetrations through the compressor housing or linkages, or both that must be lubricated and adjusted are acceptable provided the manufacturer provides a five-year inspection agreement consisting of semi-annual inspection, lubrication, and annual change out of any compressor seals. A statement of inclusion must accompany any quotations.
- B. Lubrication System: The compressor shall have an independent lubrication system to provide lubrication to all parts requiring oil. Provide a heater in the oil sump to maintain oil at sufficient temperature to minimize affinity of refrigerant, and thermostatically controlled water-cooled oil cooler. Coolers located inside the evaporator or condenser are not acceptable due to inaccessibility. A positive displacement oil pump shall be powered through the unit control transformer.
- C. Refrigerant Evaporator and Condenser:

1. Evaporator and condenser shall be of the shell-and-tube type, designed, constructed, tested and stamped according to the requirements of the ASME Code, Section VIII. Provide intermediate tube supports at a maximum of 24 inch spacing.
 2. Tubes shall be enhanced for maximum heat transfer, rolled into steel tube sheets and sealed with Locktite or equal sealer. The tubes shall be individually replaceable.
 3. Provide isolation valves and sufficient volume to hold the full refrigerant charge in the condenser or provide a separate pumpout system with storage tank.
 4. The water sides shall be designed for a minimum of 150 psig or as specified elsewhere. Vents and drains shall be provided.
 5. Evaporator minimum refrigerant temperature shall be 33°F.
 6. A self-metering and adjustable expansion valve shall control refrigerant flow to the evaporator. Fixed orifice devices or float controls with hot gas bypass are not acceptable because of inefficient control at low load conditions. The liquid line shall have a moisture indicating sight glass.
 7. The evaporator and condenser shall be separate shells. A single shell containing both vessel functions is not acceptable because of the possibility of internal leaks.
 8. Reseating type spring loaded pressure relief valves according to ASHRAE-15 safety code shall be furnished. The evaporator shall be provided with single or multiple valves. The condenser shall be provided with dual relief valves equipped with a transfer valve so one valve can be removed for testing or replacement without loss of refrigerant or removal of refrigerant from the vessel. Rupture disks are not acceptable.
 9. The condenser and any other component or part of a component subject to condensing moisture shall be insulated with UL recognized 3/4 inch closed cell insulation. All joints and seams shall be carefully sealed to form a vapor barrier.
 10. Provide water pressure differential switches on each vessel to prevent unit operation with no flow. Furnished, mounted and wired by the contractor.
- D. Prime Mover: Squirrel cage induction motor of the hermetic type of sufficient size to efficiently fulfill compressor horsepower requirements. Motor shall be liquid refrigerant cooled with internal thermal overload protection devices embedded in the winding of each phase. Motor shall be compatible with the starting method specified hereinafter. If the Contractor chooses to provided an open drive motor or compressor, verify in the submittal that the scheduled equipment room ventilation system will accommodate the additional heat and maintain the equipment room at design indoor temperature based on 95°F outdoor ambient ventilation air available.
- If additional cooling is required, manufacturer shall be responsible for the installation, wiring and controls of a cooling system.

E. Motor Starter:

1. The main motor starter is to be factory mounted and fully wired to the water heater and factory tested during the run test of the unit.

-- Or --

The main motor starter is to be furnished by the water heater manufacturer and shipped loose for floor mounting and field wiring to the chiller package. It shall be free-standing with NEMA-1 enclosure.

2. For air-cooled motors the water heater manufacturer shall be responsible for providing the cooling of the refrigeration machinery room. The sensible cooling load shall be based on the total heat rejection to the atmosphere from the refrigeration units.
3. For open motor unit, an oil reservoir shall collect any oil and refrigerant that leaks past the seal. A float device shall be provided to open when the reservoir is full, directing the refrigerant/oil mixture back into the compressor housing. Manufacturer shall warrant the shaft seal, reservoir, and float valve system against leakage of oil and refrigerant to the outside of the refrigerating unit for a period of 5 years from the initial start-up including parts and labor to replace a defective seal and any refrigerant required to trim the charge original specifications.
4. The starter must comply with the requirements of Section 1.2.
5. All controllers are to be continuous duty AC magnetic type constructed according to NEMA standards for Industrial Controls and Systems (ICS) and capable of carrying the specified current on a continuous basis. The starter shall be:

Wye-Delta Closed Transition - The wye contactor shall be capable of handling 33% of the delta locked rotor current and be equipped with properly sized resistors to provide a smooth transition. The resistors shall be protected with a transition resistor protector, tripping in a maximum of two seconds, locking out the starter, and shall be manually reset. A clearly marked transition timer shall be adjustable from 0 to 30 seconds.

-- Or --

Solid-State Reduced Voltage - Starter shall be furnished with silicon controlled rectifiers (SCR) connected for starting and include a bypass contactor. When operating speed is reached, the bypass contactor shall be energized removing the SCRs from the circuit during normal running. The starter shall be capable of across-the-line starting in an emergency.

6. The starter shall be coordinated with the water heater package(s) making certain all terminals are properly marked according to the chiller manufacturer's wiring diagrams.
7. The starters shall be equipped with redundant motor control relays (MCR) with coils in parallel. The relays interconnect the starters with the unit control panels and directly operate the main motor contactors. The MCRs shall constitute the only means of energizing the motor contacts.
8. The main contactors shall have a normally open and a normally closed auxiliary contact rated at 125VA pilot duty at 115 VAC. An additional set of normally open contacts shall be provided for each MCR.
9. There shall be electronic overloads in each phase set at 107% of the rated load amps of each motor. Overloads shall be manual reset and shall de-energize the main contactors when the overcurrent occurs. The overloads shall be adjustable and selected for mid-range. Overloads shall be adjusted for a locked

rotor trip time of 8 seconds at full voltage and must trip in 60 seconds or less at reduced voltage (33% of delta LRA).

10. Each starter shall have a current transformer and adjustable voltage dropping resistor(s) to supply a 5.0 VAC signal at full load to the unit control panels.

11. Each starter shall be equipped with a line-to-115 VAC control transformer, fused in both the primary and secondary, to supply power to the control panels, oil heaters and oil pumps.

12. Each starter shall include hase failure and reversal protection

F. CONTROL PANEL

Control is by microprocessor-based unit and compressor controllers with a 4-by-20-character display to view system parameters, denote alarms and input setpoints. The unit shall also have a 15-inch super VGA color touchscreen monitor and USB port.

The touchscreen shall have fault history and trend logging capabilities, which are transferable to other PC management systems such as an Excel spreadsheet via a USB port. Active trend logging data shall be available for viewing in 20 minute, 2 hour or 8 hour intervals. A full 30 days of history is downloadable via a USB port. The following trended parameters shall be displayed:

- Entering and leaving source water temperature
- Entering and leaving hot water temperature
- Evaporator saturated refrigerant pressure
- Condenser saturated refrigerant pressure
- Net oil pressure
- % rated load amps

In addition to the trended items above, other real-time operating parameters are also shown on the touchscreen. These items can be displayed in two ways: by a unit graphic showing each component or from a color-coded, bar chart format. At a minimum, the following critical areas must be monitored:

- Oil sump temperature
- Oil feed line temperature
- Evaporator saturated refrigerant temperature
- Suction temperature
- Condenser saturated refrigerant temperature
- Discharge temperature
- Liquid line temperature

Complete unit operating and maintenance instructions shall be viewable on the touchscreen and be downloadable via an onboard USB port.

Complete fault history shall be displayed using an easy to decipher, color coded set of messages that are date and time stamped. The last 20 faults shall be downloadable from the USB port.

Automatic corrective action to reduce unnecessary cycling shall be accomplished through pre-emptive control of low evaporator or high discharge pressure conditions to keep the unit operating through ancillary transient conditions.

Factory mounted DDC controllers shall support operation on a BACnet, Modbus or LONWORKS network via a factory-installed communication module.

Factory mounted DDC controller(s) shall support operation on a BACnet®, Modbus® or LONMARKS ® network via one of the data link / physical layers listed below as specified by the successful Building Automation System (BAS) supplier.

- BACnet MS/TP master (Clause 9)
- BACnet IP, (Annex J)
- BACnet ISO 8802-3, (Ethernet)
- LONWORKS FTT-10A. The unit controller shall be LONMARK® certified.

The information communicated between the BAS and the factory mounted unit controllers shall include the reading and writing of data to allow unit monitoring, control and alarm notification as specified in the unit sequence of operation and the unit points list.

For chillers communicating over a LONWORKS network, the corresponding LONMARK eXternal Interface File (XIF) shall be provided with the chiller submittal data.

All communication from the chiller unit controller as specified in the points list shall be via standard BACnet objects. Proprietary BACnet objects shall not be allowed. BACnet communications shall conform to the BACnet protocol (ANSI/ASHRAE135-2001). A BACnet Protocol Implementation Conformance Statement (PICS) shall be provided along with the unit submittal.

PART 3 — EXECUTION

3.1 INSTALLATION

- A. Install according to manufacturer's requirements, shop drawings, and Contract Documents.
- B. Adjust unit alignment on concrete foundations, sole plates or subbases as called for on drawings.
- C. Arrange the piping on each vessel to allow for dismantling the pipe to permit head removal and tube cleaning.
- D. Furnish and install necessary auxiliary water piping for oil cooler.
- E. Coordinate electrical installation with electrical contractor.
- F. Coordinate controls with control contractor.
- G. Provide all materiel required to ensure a fully operational and functional water heater.

3.2 START-UP

- A. Units shall be factory charged with the proper refrigerant and oil.
- B. Factory Authorized Start-Up Services: Provide for as long a time as is necessary to ensure proper operation of the unit, but in no case for less than two full working days. During the period of start-up, the Start-up Technician shall instruct the Owner's representative in proper care and operation of the unit.

This document contains the most current product information as of this printing. For the most up-to-date product information, please go to www.mcquay.com.

All McQuay equipment is sold pursuant to McQuay's Standard Terms and Conditions of Sale and Limited Product Warranty. Consult your local McQuay Representative for warranty details. Refer to form 933-430285Y-00-A (09/08). To find your local representative, go to www.mcquay.com

