

SOUTHERN OREGON UNIVERSITY REQUEST FOR PROPOSALS

#2014-0327

**Design/Build Services for Cox Hall Fire Alarm/ Mass Notification System Replacement
1400 Siskiyou Blvd., Ashland, Oregon**

ISSUE DATE: March 27, 2014

RFP CLOSING (DUE) DATE: April 15, 2014, 4:00 PM, Local Time

Important Notice: Read this RFP carefully. By submitting a Proposal in response to this RFP, you acknowledge that you have read, understand, and agree to comply with all the provisions of this RFP. SOU may modify this RFP or make additional information available to potential Proposers. It is the responsibility of potential Proposers to refer daily to the OUS Current Business and Bidding Opportunities website (<https://secure.ous.edu/bid/>) to check for any available addenda, responses to clarifying questions, or solicitation cancellations. SOU will attempt to provide notice of addendums to all firms that provide email contact information to the contact below, but are under no obligation to do so and failure to receive such notice will not be sufficient basis for protest.

CONTRACT ADMINISTRATOR: Southern Oregon University

Drew Gilliland, Director of Facilities
Phone: (541) 552-6233
FAX: (541) 552-6235
Email: <mailto:gilliland@sou.edu>

PROPOSAL SUBMITTAL LOCATION

Southern Oregon University
Facilities Management and Planning
Attention: Drew Gilliland
Director of Facilities
351 Walker Avenue
Ashland, Oregon 97520
soubid@sou.edu

NO LATE PROPOSALS WILL BE ACCEPTED

TABLE OF CONTENTS

- I. Introduction
- II. Project Description
- III. M.W.E.S.B. Management Plan
- IV. Selection Procedure
- V. Project Timetable
- VI. Proposal Submission
- VII. General RFP Provisions
- VIII. Enclosures

I. INTRODUCTION

The Oregon State Board of Higher Education, on behalf of Southern Oregon University (“**SOU**” or the “**Owner**”), is seeking Proposals from qualified firms interested in providing Design/Build services (design and installation) to SOU for a project described below (the “**Project**”). This system will be installed at Cox Hall on the SOU campus in Ashland.

In addition to the Sample Design/Build Agreement, SOU will use the July 1, 2012 Oregon University System General Conditions for Public Improvement Contracts and Supplemental General Conditions (the “**OUS General Conditions**”) as the basis for the final agreement (attached to this RFP as **Exhibits E and F**). The OUS General Conditions shall apply to the work of all subcontractors and to the work of the Design/Builder to the extent that they do not conflict with the Design/Builder Agreement.

The attached Exhibit E Sample Design/Build Agreement (also referred to herein as the Design/Build Agreement) contains contract terms and conditions and the General Conditions applicable to the Project, and will form the basis of the final Design/Build Agreement. If you are unable to comply with these terms and conditions without any material modifications, then you should not submit a Proposal for this Project.

All Proposers must be registered with the Oregon Construction Contractors Board and have the required Public Works Bond on file with the Construction Contractors Board (CCB) prior to submitting a Proposal. Failure to be registered and have the bond in place will result in the rejection of your Proposal as non-responsive. All subcontractors must file a Public Works Bond with the CCB prior to starting work on the project, unless exempt.

The Design/Build firm shall be skilled in design, construction, understanding construction methods and techniques, selecting subcontractors, coordinating construction processes, and be capable of providing consultation and assistance to the Owner. The Design/Builder must be able to communicate the design and construction-related aspects of the Project to all team members throughout the design and construction process. In addition, the Design/Builder must be familiar with the local labor and sub-contracting market and be capable of working and contracting directly with sub-contractors.

Bureau of Labor and Industries (BOLI) Prevailing Wage Rates for Residential projects are applicable to the construction phase of this Project. The Design/Builder and all subcontractors shall comply with the provisions of ORS 279C.800 through 279C.870 relative to Prevailing Wage Rates. See OUS General Conditions, Sections C.1 and C.2, regarding wage rate compliance and payroll certification requirements. Workers shall be paid the applicable rates per the January 1, 2014 BOLI Prevailing Wage Rate schedule. If a contractor fails to pay for labor or services, SOU can pay and withhold these amounts from payments due the Design/Builder (ORS 279C.5.15). The Design/Builder and their subcontractors shall provide a written schedule to employees showing the number of hours per day and days per week the employee may be required to work (ORS 279C.520). The Design/Builder and their subcontractors must promptly pay for any medical services they have agreed to pay (ORS 279C.530).

Compensation shall be based upon a lump sum price to include all design and construction services, as set forth in the Sample Design/Build Agreement attached. Related contracting provisions are contained in **Exhibits A through H** as detailed in **Part VIII** of this RFP entitled "Enclosures".

II. PROJECT DESCRIPTION

The project consists of design and installation of a new fire alarm and mass notification system in Cox Hall at Southern Oregon University in Ashland, Oregon. The original Cox Hall is a dormitory building that was constructed in 1957. A four-story addition at the east side was built in 2001. This project is to replace the existing fire alarm system in the entire facility. The new system must be compatible with, and interconnected to, the existing campus fire alarm and mass notification systems. Portions of the existing alarm system can be reused at the Design/Builder's option as long as the completed system complies with all code and jurisdiction requirements. The Design/Builder shall submit design drawings and calculations to the City for review, secure and pay for all permits and obtain required inspections from the City of Ashland and Ashland Fire Department.

Systems by Johnson Controls, Notifier and Simplex are approved for this project. The mass notification system must be audible at all interior building areas. Allow for installation of two exterior speakers for broadcasting mass notification messages.

SOU has basic AutoCAD floor plans available for Cox Hall (see Exhibit H for pdf version). Exhibit I contains the drawings for the 2001 fire alarm system.

III. MWESB MANAGEMENT PLAN

The State Board of Higher Education strongly encourages the utilization of minority-owned, woman-owned, and emerging small businesses (MWESB) on our capital construction projects. It is OUS policy to award a minimum of 10% of points for Proposals based on a Management Plan that details bidder's plans to subcontract with MWESBs or use MWESB suppliers. The Management Plan can also include discussion of your firm's commitment to employing a diverse workforce and participation in outreach to the MWESB community. The Management Plan should provide a historical narrative of your firm's use of MWESB businesses on projects of similar size and scope as this Project. Submit the MWESB management plan as a separate document along with the Design/Build Proposal form.

IV. SELECTION PROCEDURE

Proposals will be evaluated by the selection committee which will be comprised of representatives from SOU.

V. PROJECT TIMETABLE

Project timetable is approximately as follows:

March 27, 2014	RFP Issued
April 4, 2014 1:00 p.m.	Optional Pre-Proposal Meeting on Site
April 7, 2014 1:00 p.m.	Written Questions Due from Proposers
April 8, 2014 4:00 p.m.	Response to Questions Posted on Website
April 15, 2014 4:00 p.m.	Proposals Submitted to SOU
April 15, 2014 4:00 p.m.	Design/Builder Selection Intent to Award
April 22, 2014	Signed Contract. Commence Design Work
June 30, 2014	Project Completion

VI. PROPOSAL SUBMISSION

Design/Build proposals must be submitted on the enclosed form and received by **April 15, 2014 at 4:00 p.m. local time**. On the Bid Form, bidders are required to list key personnel proposed for the Project, references for three (3) comparable projects, and equipment proposed for use in this Project.

Submit **Proposals to:**

Drew Gilliland

Director of Facilities

Southern Oregon University

351 Walker Avenue

Ashland OR 97520

Phone: 541-552-6233 FAX: 541-552-6235

email: soubid@sou.edu

Sealed, hand delivered or emailed proposals are acceptable for this project. Responses received after the closing date and time will not be considered.

VII. GENERAL RFP PROVISIONS

1. Questions and General Information:

All questions and contacts with SOU regarding any information in this RFP must be addressed either in writing, fax, or email to:

Keith Beed
SOU Utilities Supervisor
351 Walker Avenue
Ashland OR 97520
Phone: 541-552-8435 FAX: 541-552-6235
email: <mailto:beedk@sou.edu>

If you are unclear about any information contained in this document (project description, scope, response format, etc.), you are urged to submit those questions for formal clarification. All questions and answers received by SOU in regards to this solicitation will be posted on the OUS bidding opportunities website as an addendum.

2. Investigation of References:

Owner reserves the right to investigate all references in addition to supplied references and investigate past performance of any Proposer with respect to its successful performance of similar services, compliance with specifications and contractual obligations, completion or delivery of a project on schedule, and lawful payment of subcontractors and employees. Owner may postpone the award or the execution of the contract after the announcement of the apparent successful proposer in order to complete its investigation. Information provided by references may prevail in final selection, regardless of preliminary scoring results.

Despite its right to investigate all Proposer references, Owner is not obligated to utilize references as part of its evaluation criteria and may decline to investigate or consider references. Any decision made by Owner in regards to the use of references, including restricting the consideration of references to only Finalists, will not be considered grounds for protest.

3. Financial Capacity:

Owner reserves the right to investigate and evaluate, at any time prior to award and execution of the contract, the Proposer's financial capacity to perform the contemplated Services. Submission of Proposals shall constitute approval for Owner to obtain any credit report information Owner deems necessary to conduct the evaluation. Owner shall notify the firms, in writing, of any other documentation required, which may include, but need not be limited to: recent profit-and-loss history; current balance statements; assets-to-liabilities ratio, including number and amount of secured versus unsecured creditor claims; availability of short and long-term financing; bonding

capacity and credit information, etc. Failure to promptly provide this information shall result in rejection of the submission.

Owner may postpone the award or execution of a contract or selection of finalists in order to complete its investigation and evaluation. Failure of a firm to demonstrate financial capacity shall render them non-responsible and shall constitute grounds for response rejection.

4. Modification or Withdrawal of Proposal: Any Proposal may be modified or withdrawn at any time prior to the Closing Date and Time, provided that a written request is received by Owner's Representative prior to the Closing Date and Time. The withdrawal of a Proposal will not prejudice the right of a Proposer to submit a new proposal.

5. Protests of Specifications: Protests of the RFP specifications may be made only if a term or condition of the RFP violates Applicable Law. Protests of Specifications must be received in writing prior to the date and time indicated in the Project Timetable at Owner's Representative address or email address listed under "General Information" in this Section IV. Protests may not be emailed or faxed. Protests of the RFP specifications must include the reason for the protest and any proposed changes to the requirements.

6. Requests for Clarification and Requests for Change: Proposers may submit questions regarding the specifications of the RFP. Questions must be received in writing prior to the date and time indicated in the Project Timetable at Owner's Representative address or email address listed under "General Information" in this RFP. Requests for changes must include the reason for the change and any recommended modifications to the RFP requirements. The purpose of this requirement is to permit Owner to correct, prior to consideration of the Proposals, RFP terms or technical requirements that may be improvident or which unjustifiably restrict competition.

7. Addenda: If any part of this RFP is amended, addenda will be provided on OUS's Current Business and Bidding Opportunities website (<https://secure.ous.edu/bid/>). Proposers are exclusively responsible for checking OUS's Current Business and Bidding Opportunities website to determine whether any addenda have been issued. **By submitting a Proposal, each Proposer thereby agrees that it accepts all risks and waives all claims associated with or related to its failure to obtain any addendum or addendum information.**

8. Post-Selection Review and Protest of Award: Owner will name the apparent successful Proposer in a "Notice of Intent to Award" email. Identification of the apparent successful Proposer is procedural only and creates no right in the named Proposer to award of the contract. Competing Proposers will be notified in writing of the selection of the apparent successful Proposer and shall be given seven (7) calendar days from the date on the "Notice of Intent to Award" letter to request and review documents regarding the selection process and to file a written protest of award. Any protest must comply with OAR 580-061-0145. Any award protest must be received in writing at Owner's Representative address or email address listed under "General Information" in this RFP.

Owner will consider any protests received and:

(A) reject all protests and proceed with final evaluation of, and any contract language

negotiation with, the apparent successful Proposer and, pending the satisfactory outcome of this final evaluation and negotiation, enter into a contract with the named Proposer; OR

(B) sustain a meritorious protest(s) and reject the apparent successful Proposer as nonresponsive if such Proposer is unable to demonstrate that its Proposal complied with all material requirements of the solicitation and Oregon public procurement law; thereafter, Owner may name a new apparent successful Proposer; OR

(C) reject all Proposals and cancel the procurement.

Owner's Vice President for Finance and Administration or designee will timely respond to any protests after receipt. The decision shall be final.

9. Acceptance of Contractual Requirements: Failure of the selected Proposer to execute a contract and deliver required insurance certificates within ten (10) calendar days after notification of an award may result in cancellation of the award. This time period may be extended at the option of Owner.

10. Public Records: Proposals are deemed confidential until the "Notice of Intent to Award" is issued. This RFP and one copy of each original Proposal received in response to it, together with copies of all documents pertaining to the award of a contract, will be kept and made a part of a file or record which will be open to public inspection. If a Proposal contains any information that is considered a **TRADE SECRET** under the Oregon Revised Statutes ("ORS") 192.501(2), **SUCH INFORMATION MUST BE LISTED ON A SEPARATE SHEET CAPABLE OF SEPARATION FROM THE REMAINING PROPOSAL AND MUST BE CLEARLY MARKED WITH THE FOLLOWING LEGEND:**

"This information constitutes a trade secret under ORS 192.501(2), and shall not be disclosed except in accordance with the Oregon Public Records Law, ORS Chapter 192."

By submitting a Proposal in response to this RFP, Proposers acknowledge and agree that any information not set apart and labeled as described above is not a trade secret under ORS 192.501(2) and may be subject to disclosure under the Oregon Public Records Law. The Oregon Public Records Law exempts from disclosure only bona fide trade secrets, and the exemption from disclosure applies only "unless the public interest requires disclosure in the particular instance." ORS 192.500(1). Therefore, non-disclosure of documents or any portion of a document submitted as part of a Proposal, including those labeled as Trade Secrets, may depend upon official or judicial determinations made pursuant to the Public Records Law.

11. RFP Preparation Costs: Cost of developing the Proposal, attendance at an interview (if requested by Owner) or mandatory walk-through, or any other such costs are entirely the responsibility of the Proposer and will not be reimbursed by Owner. By submitting a Proposal, each Proposer thereby accepts all risks, and waives all claims, associated with or related to the costs it incurs in Proposal preparation, submission, and participation in the solicitation process.

12. Clarification and Clarity: Owner reserves the right to seek clarification of each Proposal or to make an award without further discussion of Proposals received. Therefore, it is important that each Proposal initially be submitted in the most complete, clear, and favorable manner possible.

13. Right to Reject Proposals: Owner reserves the right to reject any or all Proposals if such rejection would be in the public interest. Whether such rejection is in the public interest will be solely determined by Owner.

14. Cancellation: Owner reserves the right to cancel or postpone this RFP at any time or to award no contract.

15. Proposal Terms: All Proposals, including any price quotations, will be valid and firm through the period of contract execution.

16. Usage: It is the intention of Owner to utilize the services of the successful Proposer to provide Services as outlined in Sections I and II of this RFP.

17. Review for Responsiveness: Upon receipt of all Proposals, Owner's Representative or designee will determine the responsiveness of all Proposals before submitting them to the evaluation committee. If a Proposal is incomplete or unresponsive in part or in whole, it may be rejected and, if rejected, will not be submitted to the evaluation committee. Owner reserves the right to determine if an inadvertent error is solely clerical or is a minor informality which may be waived when determining if an error is grounds for disqualifying a Proposal. The Proposer's contact person identified in the Proposal will be notified by Owner to communicate the reason(s) the Proposal is non-responsive. One copy of the Proposal will be archived.

18. Rejections and Withdrawals. Owner reserves the right to reject any or all Proposals or to withdraw any item from the award.

19. RFP Incorporated into Contract. This RFP will become part of the final contract between the Owner and the selected Proposer (also referred to herein as the "Contractor"). The Contractor will be bound to perform according to the terms of this RFP, its Proposal, and the terms of Exhibits E, F and G.

20. Communication Blackout Period. Except as called for in this RFP, Proposers may not communicate about this RFP with members of the evaluation committee or any employees of Owner until the apparent successful Proposer is selected and all protests, if any, have been resolved. The contact person designated by the "General Information" section of this RFP is exempted from this blackout period. If any Proposer initiates or continues contact in violation of this provision, Owner may, in its sole discretion, reject that Proposer's Proposal and remove it from consideration for award of a contract under this RFP.

21. Ownership of Proposals. All Proposals in response to this RFP are the sole property of Owner and subject to the provisions of ORS 192.410-192.505 (the Public Records Act).

22. Clerical Errors in Awards. Owner reserves the right to correct inaccurate awards resulting from its clerical errors.

23. Rejection of Qualified Proposals. Proposals may be rejected in whole or in part if they limit or modify any of the terms and conditions and/or specifications of the RFP. Any terms contained in Proposals that conflict with or modify the terms of this RFP and sample contract are expressly rejected unless specifically adopted in writing by Owner.

24. Collusion. By responding, the Proposer states that the proposal is not made in connection with any competing Proposer submitting a separate response to the RFP, and is, in all aspects, fair and without collusion or fraud.

25. Commencement of Work: The Contractor shall commence no Services until all insurance requirements have been met, the Protest of Awards deadline has been passed, and a contract has been fully executed.

26. EQUAL EMPLOYMENT COMPLIANCE

By submitting a Proposal, the Proposer certifies conformance to the applicable federal, state and local laws, acts executive orders, statutes, administrative rules, regulations, ordinances and related court rulings concerning Affirmative Action toward Equal Employment Opportunities. All information and reports required by the Federal or Oregon State or local Governments having responsibility for the enforcement of the foregoing shall be supplied to Owner upon request for purposes of investigation to ascertain compliance with the foregoing.

Owner is committed to increasing opportunities for Emerging Small Businesses and Minority and Women Owned Businesses, and Owner strongly encourages its contractors to use these businesses in providing services and materials for Owner contracts and projects.

Pursuant to OAR 580-061-0030, by submitting a Proposal, the Proposer certifies that the Proposer has not discriminated against Minority, Women or Emerging Small Business Enterprises in obtaining any required subcontracts.

Pursuant to OAR 580-061-0040, Proposers are hereby notified that the OSBHE has adopted policies applicable to consultants and contractors that prohibit sexual harassment and those Proposers and their employees are required to adhere to Owner's policy prohibiting sexual harassment in their interactions with members of Owner's community.

27. CERTIFICATION OF COMPLIANCE WITH TAX LAWS

By submission of the Proposal, the undersigned hereby certifies under penalty of perjury that the undersigned is authorized to act on behalf of Contractor and that Contractor is, to the best of the undersigned's knowledge, not in violation of any Oregon Tax Laws. For purposes of this certification, "Oregon Tax Laws" means a state tax imposed by ORS 401.792 to 401.816 and ORS chapters 118, 314, 316, 317, 318, 320, 321 and 323; the elderly rental assistance program under ORS 310.630 to 310.706; and local taxes administered by the Department of Revenue

under ORS 305.620.

VIII. ENCLOSURES

Exhibit A - Design/Build Agreement Proposal Form – RFP 2014-0327

Exhibit B - Performance Bond Form

Exhibit C - Payment Bond Form

Exhibit D - “Sample” Design/Build Agreement Form

Exhibit E - OUS General Conditions

Exhibit F - OUS Supplemental General Conditions

Exhibit G – Building Floor Plans

Exhibit H - Existing Fire Alarm Drawings

OREGON UNIVERSITY SYSTEM
DESIGN/BUILD AGREEMENT
PROPOSAL FORM-RFP #2014-0327

OUS CAMPUS: Southern Oregon University

PROJECT: Cox Hall Fire Alarm Replacement

PROPOSAL CLOSING: **April 15, 2014 at 4:00 p.m.**

PROPOSAL OPENING: **April 15, 2014 at 4:00 p.m.**

FROM: _____
Name of Contractor

TO: Oregon State Board of Higher Education
Southern Oregon University
351 Walker Avenue
Ashland, Oregon 97520

1. The Undersigned (*check one of the following and insert information requested*):

___ a. An individual doing business under an assumed name registered under the laws of the State of _____; or

___ b. A partnership registered under the laws of the State of _____;

or

___ c. A corporation organized under the laws of the State of _____; or

___ d. A limited liability corporation organized under the laws of the State of _____

hereby proposes to furnish all material and labor and perform all work hereinafter indicated to provide Design Services and Construction Work for the above project in strict accordance with the Request for Proposals:

Base Proposal - Complete Cost for a Code Compliant Fire Alarm System with Mass Notification Included, Interconnected with the Existing Campus Systems.

_____ Dollars (\$_____)

and the Undersigned agrees to be bound by the following documents:

- RFP #2014-0327
 - OUS General Conditions
 - Prevailing Wage Rates
 - Design/Build Agreement
 - OUS Supplemental General Conditions
 - Payroll and Certified Statement Form
- ADDENDA numbered ____ through ____, inclusive (*fill in blanks*)

2. The Undersigned proposes to add to the Base Proposal indicated above the items of work relating to the following Alternate(s): **No Alternates**

3. No Proposal Security is required for this project.

4. Performance and Payment Bonds required for this project equal to the contract amount.

5. The Undersigned certifies that: (1) This Proposal has been arrived at independently and is being submitted without collusion with and without any agreement, understanding, or planned common course of action with any other vendor of materials, supplies, equipment or services described in the RFP designed to limit independent bidding or competition; and (2) The contents of this Proposal have not been communicated by the Undersigned or its employees or agents to any person not an employee or agent of the Undersigned or its surety on any Bond furnished with the Proposal and will not be communicated to such person prior to the official opening of the Proposal.

6. The undersigned **HAS, HAS NOT** (*circle applicable status*) paid unemployment or income taxes in Oregon within the past 12 months and **HAS, HAS NOT** (*circle applicable status*) a business address in Oregon.

7. The Undersigned agrees, if awarded a contract, to comply with the provisions of ORS 279C.800 through 279C.870 pertaining to the payment of the prevailing rates of wage.

8. Contractor's CCB registration number is _____. As a condition to submitting a Proposal, a Contractor must be registered with the Oregon Construction Contractors Board in accordance with ORS 701.035 to 701.055, and disclose the registration number. Failure to register and disclose the number will make the proposal unresponsive and it will be rejected, unless contrary to federal law.

9. The successful Proposer hereby certifies that all subcontractors who will perform construction work as described in ORS 701.005(2) were registered with the Construction Contractors Board in accordance with ORS 701.035 to 701.055 at the time the subcontractor(s) made a proposal to work under the contract.

10. The successful Proposer hereby certifies that, in compliance with the Worker's Compensation Law of the State of Oregon, its Worker's Compensation Insurance provider is _____, Policy No. _____, and that Contractor shall submit Certificates of Insurance as required.

11. The Undersigned certifies that it has not discriminated against minority, women, or

emerging small businesses in obtaining any subcontracts for this project.

12. Contractor's Key Personnel. The Contractor's project staff for this project shall consist of the following personnel:

Principal-in-Charge: _____

Project Manager: _____

Design Professionals: _____ (License #_____)
_____ (License #_____)

On-Site Job Superintendent: _____

13. Design-Build References. Provide the names, addresses, and phone numbers of three Owners to be used as references for this project. These references should be from projects that have relevance to the project identified in the Request for Proposals. Verify that the individuals referenced have had direct contact with the referenced project, and the phone numbers are accurate. SOU may check with these references and/or may check with other references associated with past work of your firm.

Name of Reference #1: _____
Company: _____
Address: _____
Phone Number: _____
Project Description: _____

Name of Reference #2: _____
Company: _____
Address: _____
Phone Number: _____
Project Description: _____

Name of Reference #3: _____
Company: _____
Address: _____
Phone Number: _____
Project Description: _____

By signature below, Contractor agrees to be bound by this Proposal.

NAME OF FIRM _____

ADDRESS _____

FEDERAL TAX ID _____

TELEPHONE NO _____

FAX NO _____

SIGNATURE 1) _____

Sole Individual

or 2) _____

Partner

or 3) _____

Authorized Officer of Corporation

(SEAL)

Attested: Secretary of Corporation

Payment information will be reported to the IRS under the name and taxpayer ID # provided above. Information not matching IRS records could subject Contractor to 31 percent backup withholding.

******* END OF PROPOSAL *******

OREGON UNIVERSITY SYSTEM
STANDARD PUBLIC IMPROVEMENT CONTRACT
PERFORMANCE BOND

Bond No. _____
Solicitation _____
Project Name _____

_____ (Surety #1)	Bond Amount No. 1:	\$ _____
_____ (Surety #2)*	Bond Amount No. 2:*	\$ _____
<i>* If using multiple sureties</i>	Total Penal Sum of Bond:	\$ _____

We, _____ as Principal, and the above identified Surety(ies), authorized to transact surety business in Oregon, as Surety, hereby jointly and severally bind ourselves, our respective heirs, executors, administrators, successors and assigns firmly by these presents to pay unto the State of Oregon, acting by and through the State Board of Higher Education, on behalf of the Oregon University System (OUS), the sum of (Total Penal Sum of Bond) _____
(Provided, that we the Sureties bind ourselves in such sum “jointly and severally” as well as “severally” only for the purpose of allowing a joint action or actions against any or all of us, and for all other purposes each Surety binds itself, jointly and severally with the Principal, for the payment of such sum only as is set forth opposite the name of such Surety), and

WHEREAS, the Principal has entered into a contract with the OUS, the plans, specifications, terms and conditions of which are contained in the above-referenced Solicitation;

WHEREAS, the terms and conditions of the contract, together with applicable plans, standard specifications, special provisions, schedule of performance, and schedule of contract prices, are made a part of this Performance Bond by reference, whether or not attached to the contract (all hereafter called “Contract”); and

WHEREAS, the Principal has agreed to perform the Contract in accordance with the terms, conditions, requirements, plans and specifications, and all authorized modifications of the Contract which increase the amount of the work, the amount of the Contract, or constitute an authorized extension of the time for performance, notice of any such modifications hereby being waived by the Surety:

NOW, THEREFORE, THE CONDITION OF THIS BOND IS SUCH that if the Principal herein shall faithfully and truly observe and comply with the terms, conditions and provisions of the Contract, in all respects, and shall well and truly and fully do and perform all matters and things undertaken by Contractor to be performed under the Contract, upon the terms set forth therein,

and within the time prescribed therein, or as extended as provided in the Contract, with or without notice to the Sureties, and shall indemnify and save harmless the OUS, and _____ (name of institution and any other Owner agency), and members thereof, its officers, employees and agents, against any direct or indirect damages or claim of every kind and description that shall be suffered or claimed to be suffered in connection with or arising out of the performance of the Contract by the Principal or its subcontractors, and shall in all respects perform said contract according to law, then this obligation is to be void; otherwise, it shall remain in full force and effect.

Nonpayment of the bond premium will not invalidate this bond, nor shall the State of Oregon or the OUS, be obligated for the payment of any premiums.

This bond is given and received under authority of ORS Chapters 279C and 351, the provisions of which hereby are incorporated into this bond and made a part hereof.

IN WITNESS WHEREOF, WE HAVE CAUSED THIS INSTRUMENT TO BE EXECUTED AND SEALED BY OUR DULY AUTHORIZED LEGAL REPRESENTATIVES.

Dated this _____ day of _____, 20__.

PRINCIPAL: _____

By _____
Signature

Official Capacity

Attest: _____
Corporation Secretary

SURETY: _____

[Add signatures for each surety if using multiple bonds]

BY ATTORNEY-IN-FACT:

[Power-of-Attorney must accompany each surety bond]

Name

Signature

Address

City State Zip

Phone Fax

OREGON UNIVERSITY SYSTEM

STANDARD PUBLIC IMPROVEMENT CONTRACT

PAYMENT BOND

Bond No. _____
Solicitation _____
Project Name _____

_____ (Surety #1) Bond Amount No. 1: \$ _____
_____ (Surety #2)* Bond Amount No. 2:* \$ _____
** If using multiple sureties* Total Penal Sum of Bond: \$ _____

We, _____, as Principal, and the above identified Surety(ies), authorized to transact surety business in Oregon, as Surety, hereby jointly and severally bind ourselves, our respective heirs, executors, administrators, successors and assigns firmly by these presents to pay unto the State of Oregon, acting by and through the State Board of Higher education, on behalf of the Oregon University System (OUS), the sum of (Total Penal Sum of Bond) _____ (Provided, that we the Sureties bind ourselves in such sum "jointly and severally" as well as "severally" only for the purpose of allowing a joint action or actions against any or all of us, and for all other purposes each Surety binds itself, jointly and severally with the Principal, for the payment of such sum only as is set forth opposite the name of such Surety), and

WHEREAS, the Principal has entered into a contract with the OUS, the plans, specifications, terms and conditions of which are contained in above-referenced Solicitation;

WHEREAS, the terms and conditions of the contract, together with applicable plans, standard specifications, special provisions, schedule of performance, and schedule of contract prices, are made a part of this Payment Bond by reference, whether or not attached to the contract (all hereafter called "Contract"); and

WHEREAS, the Principal has agreed to perform the Contract in accordance with the terms, conditions, requirements, plans and specifications, and schedule of contract prices which are set forth in the Contract and any attachments, and all authorized modifications of the Contract which increase the amount of the work, or the cost of the Contract, or constitute authorized extensions of time for performance of the Contract, notice of any such modifications hereby being waived by the Surety:

NOW, THEREFORE, THE CONDITION OF THIS BOND IS SUCH that if the Principal shall faithfully and truly observe and comply with the terms, conditions and provisions of the Contract, in all respects, and shall well and truly and fully do and perform all matters and things by it undertaken to be performed under said Contract and any duly authorized modifications that are made, upon the terms set forth therein, and within the time prescribed therein, or as extended therein as provided in the Contract, with or without notice to the Sureties, and shall indemnify and save harmless the OUS and _____ (name of institution and any other Owner agency), and members thereof, its officers, employees and agents, against any claim for direct or indirect damages of every kind and description that shall be suffered or

claimed to be suffered in connection with or arising out of the performance of the Contract by the Contractor or its subcontractors, and shall promptly pay all persons supplying labor, materials or both to the Principal or its subcontractors for prosecution of the work provided in the Contract; and shall promptly pay all contributions due the State Industrial Accident Fund and the State Unemployment Compensation Fund from the Principal or its subcontractors in connection with the performance of the Contract; and shall pay over to the Oregon Department of Revenue all sums required to be deducted and retained from the wages of employees of the Principal and its subcontractors pursuant to ORS 316.167, and shall permit no lien nor claim to be filed or prosecuted against the State on account of any labor or materials furnished; and shall do all things required of the Principal by the laws of this State, then this obligation shall be void; otherwise, it shall remain in full force and effect.

Nonpayment of the bond premium will not invalidate this bond, nor shall the State of Oregon, or the OUS be obligated for the payment of any premiums.

This bond is given and received under authority of ORS Chapters 279C and 351, the provisions of which hereby are incorporated into this bond and made a part hereof.

IN WITNESS WHEREOF, WE HAVE CAUSED THIS INSTRUMENT TO BE EXECUTED AND SEALED BY OUR DULY AUTHORIZED LEGAL REPRESENTATIVES:

Dated this _____ day of _____, 20__.

PRINCIPAL: _____

By _____
Signature

Official Capacity

Attest: _____
Corporation Secretary

SURETY: _____

[Add signatures for each if using multiple bonds]

BY ATTORNEY-IN-FACT:

[Power-of-Attorney must accompany each bond]

Name

Signature

Address

City State Zip

Phone Fax

**“SAMPLE”
DESIGN/BUILD AGREEMENT**

OWNER: State of Oregon acting by and through
the Board of Higher Education on behalf
of Southern Oregon University (the "Owner")

DESIGN/BUILDER: _____ (the "CONTRACTOR")

PROJECT: **Cox Hall Fire Alarm Replacement** (the "Project")

(The Owner and the Design/Builder are collectively referred to hereafter as the "Parties")

RECITALS

- A. WHEREAS, Owner owns and operates the Facility described as the North Campus Village; North Residence Hall; and
- B. WHEREAS, Owner issued a Request for Proposals (the "RFP") dated November 26, 2013 in order to obtain the services of a **Design/Builder** (the "CONTRACTOR") to competently assume responsibility for completion of the design and construction of a solar photovoltaic system at the Stevenson Union (the "Project"); and
- C. WHEREAS, CONTRACTOR submitted a written Proposal in response to Owner's RFP and Owner selected CONTRACTOR as the most qualified responsive and responsible design/builder to complete the Project; and
- D. WHEREAS, Owner and Contractor now wish to memorialize their respective rights and responsibilities regarding Contractor's design and construction of the solar photovoltaic system at the North Campus Village; North Residence Hall; and
- E. WHEREAS, Owner is authorized under the laws of the State of Oregon to enter into the Contract for the purposes set forth herein.

NOW, THEREFORE, in consideration of the mutual promises contained in this document, and intending to be legally bound hereby, Owner and Contractor agree as follows:

AGREEMENT

1. DEFINITIONS

Key terms used within the Contract are defined at **Section A.1** of the Oregon University System General Conditions for Public Improvement Contracts, revised May 1, 2012 (the

“**OUS General Conditions**”), except as modified or supplemented as follows:

- 1.1 “Agreement” means this 21 page document entitled, “Design/Build Agreement,” excluding exhibits and material incorporated herein by reference, and is interchangeable with the term “OUS Public Improvement Agreement form” used in Section A.1 of the OUS General Conditions.
- 1.2 “Contract Documents” means the documents identified in **Section 2.1** of this Agreement.
- 1.3 “Construction Documents” means Owner-approved Plans, drawings, Specifications and other documents necessary to allow complete and accurate construction of the Project.
- 1.4 “Construction Work” or “Work” means the providing of all work, services, construction management services, materials, equipment, transportation, tools, labor and incidentals necessary to complete the construction work described in and reasonably inferred from the Contract Documents, including but not limited to the services and work set forth in Section 3.5 of this Agreement.
- 1.5 “Contract Price” means that amount set forth in the Contractor’s Proposal pertaining to the total fixed cost of the Project for both Design Services and Construction Work.
- 1.6 “Design/Builder” means the Contractor in its capacity of being responsible for providing all services necessary to achieve the purposes and intent of the RFP including without limitation, Project coordination and supervision, architectural and engineering design, procurement of goods, materials and services necessary to complete the Project, Construction Work, and commissioning services.
- 1.7 “Design Professional” means: 1) an architect who is registered and holds a valid certificate in the practice of architecture in the State of Oregon; 2) an engineer who is registered and holds a valid certificate in the practice of engineering in the State of Oregon; 3) a surveyor who is registered and holds a valid certificate in the practice of land surveying in the State of Oregon; and 4) such other professional person or entity otherwise registered and holding a valid certificate to provide professional design services in the State of Oregon.
- 1.8 “Design Services” means all the design services, construction administration services and related services to be performed by the Contractor under the Contract, including but not limited to Sections 3.3 and 3.4 of this Agreement and as described in Exhibit 6.
- 1.9 “Direct Construction Costs” means the costs to the Owner of all divisions of construction, including portable equipment designed or specified in the construction Specifications.
- 1.10 “Facility” means North Campus Village; North Residence Hall located at 445

Stadium Street in Ashland, OR.

- 1.11 “Notice to Proceed” means the official written notice from Owner that indicates that all of the threshold contractual requirements have been met, including full negotiation of Contract terms, execution and delivery of all Contract Documents, Owner’s receipt of acceptable and fully executed performance and payment bonds and certificates of insurance, and that the Contractor is authorized to proceed with the work.
- 1.12 “Owner” means the State of Oregon acting by and through the Oregon State Board of Higher Education on behalf of Southern Oregon University.
- 1.16 “RFP” means that Request for Proposals dated September 12, 2013, to which this form of Contract is attached and pursuant to which this completed Contract is drafted and executed by the Parties.
- 1.17 “Statement of Work” means the Design Services and Construction Work set forth in detail in the Construction Documents.
- 1.18 “Work Product” means the work product required to be delivered by CONTRACTOR under the Contract, as more particularly defined in **Section 3.3** of this Agreement.
- 1.19 “Project Management Services” means the project management services that the CONTRACTOR will perform throughout the period of performance of the Contract, as more particularly described in Section 3.2 of this Agreement.

2. CONTRACT DOCUMENTS; OWNERSHIP OF WORK PRODUCT

The Contract Documents listed in **Section 2.1 below** of this Design/Build Agreement (the “Contract Documents”) are intended to reflect the Parties’ understanding of their respective rights and responsibilities concerning completion of the Work within the Contract Time and for the Contract Price.

- 2.1 Interpretation.** Notwithstanding the order of precedence provision set forth in Section A.3.1 of the OUS General Conditions, in the event of any inconsistency, conflict, or ambiguity between or among the Contract Documents, the Contract Documents shall take precedence in the following order:
 - 2.1.1** All written modifications, amendments and change orders to this Contract that have been executed by Owner following any required State of Oregon governmental approvals;
 - 2.1.2** This Agreement, minus exhibits and material incorporated by reference;
 - 2.1.3** The OUS General Conditions;
 - 2.1.4** All design and construction drawings, Plans, Specifications and documents prepared and approved for the Project;
 - 2.1.5** The RFP and all attachments thereto generated as part of services/work.

2.1.6 The Contractor's Proposal submitted in response to the RFP.

2.1.7 Remaining documents incorporated into the Contract by reference.

The OUS General Conditions, to the extent not inconsistent with the Contract, shall also apply to the work of all subcontractors performing work on the Project.

2.2 Ownership of Work Product. All drawings, Plans, Specifications, prototypes, reports, and other work product required to be delivered by CONTRACTOR under the Contract ("**Work Product**") shall be the exclusive property of Owner. Owner and CONTRACTOR intend that such Work Product be deemed "work made for hire." If for any reason the Work Product is not deemed "work made for hire," CONTRACTOR hereby irrevocably assigns to Owner all of its right, title and interest in and to any and all of the Work Product, whether arising from copyright, or any state or federal intellectual property law or doctrine. CONTRACTOR shall execute such further documents and instruments as Owner may reasonably request in order to fully vest such rights in Owner. CONTRACTOR forever waives any and all rights relating to the Work Product, including without limitation, any and all rights arising under 17 USC §106A or any other rights of identification of authorship or rights of approval, restriction or limitation on use or subsequent modifications.

2.2.1 CONTRACTOR, notwithstanding other conditions in this **Section 2.1**, shall have the right to utilize such Work Product on its brochures or other literature that it may utilize for marketing and sales, and in addition, CONTRACTOR may use standard line drawings, Specifications and calculations on other unrelated projects.

3. CONTRACTOR'S SERVICES

3.1 General.

3.1.1 As the Design/Builder for this Project, CONTRACTOR shall perform all Project Management Services, Design Services, and Construction Work necessary to complete the Project.

3.1.2 CONTRACTOR shall obtain at its own expense, and shall maintain in effect for the duration of the Contract, the insurance coverage required in **Section G** of the OUS General Conditions.

3.1.3 CONTRACTOR shall perform all services in good faith and shall perform all Design Services and Construction Work as expeditiously as is consistent with the highest professional skill, care and the orderly progress of that work.

3.1.4 Within one week after execution of this Agreement, CONTRACTOR shall submit for Owner's approval a schedule for the performance of CONTRACTOR's Design Services and Construction Work, which shall include allowances for periods of time required for Owner's review and for approval of submissions by authorities having jurisdiction over the Project. Time limits established by this schedule and approved by Owner shall not, except for reasonable cause, be exceeded by CONTRACTOR or Owner.

3.2 Project Management.

- 3.2.1** CONTRACTOR shall appoint a CONTRACTOR staff person as CONTRACTOR's Project Manager (the "CPM", who is identified in **Section 4** of this Agreement) who will be reasonably available to Owner and who shall have the expertise and experience required to supervise the Work for the duration of the Project. CPM shall communicate regularly with Owner and shall have the authority to act on behalf of CONTRACTOR. CPM shall consult with the Owner's Project Manager (the "OPM") on issues affecting design, construction, Contract performance, Project budget and Project schedule. The CPM may be replaced during the Project only with Owner's prior consent, consistent with the provisions of **Section 4.5** of this Agreement.
- 3.2.2** The CPM shall provide Owner with a status report every two weeks, in which it shall detail the progress of the Work including the following: 1) whether the Work is proceeding according to schedule; 2) any discrepancies, conflicts, or ambiguities in the Construction Documents that require resolution; 3) any safety issues related to the Work; 4) any other matter that requires resolution to ensure timely and cost-effective completion of the Work. At least four working days prior to the scheduled meeting, CONTRACTOR shall submit to Owner a list of identified matters that will require resolution; any matters that require Owner approvals, and any proposed deviations from the Project schedule.
- 3.2.3** The CPM shall be the principal contact between the OPM and all other CONTRACTOR representatives, and will be responsible for all communications, including, but not limited to, conveying concerns, decisions and formal actions.
- 3.2.4** The CPM shall be responsible for maintaining thorough and complete project records and regular briefings to the OPM. The CPM will coordinate the flow of information, communications and formal documents so that Owner has the material required for its timely action on policy, design and budget matters. The CPM will be responsible for transmission of documentation required for Owner approval or actions.
- 3.2.5** Owner's review of, and response to, any of the matters presented above shall not relieve CONTRACTOR of its obligation to complete the Design Services and Construction Work within the Contract Times set forth in Section 14 of this Agreement, and shall not be construed as relieving CONTRACTOR of its complete and exclusive control over the means, methods, sequences and techniques for executing the work.

3.3 Design.

CONTRACTOR shall prepare, for approval by Owner, Construction Documents, consisting of drawings, Plans, Specifications and other documents as required for the Master Permit Program and construction of the entire Project.

- 3.3.1.** The Construction Documents must meet the following requirements:

3.3.1.1 CONTRACTOR shall provide drawings and Plans which set forth the architectural, structural, mechanical and electrical construction requirements for the Project.

3.3.1.2 CONTRACTOR shall provide Owner with catalog cuts of all items not specified in the RFP.

3.3.1.3 CONTRACTOR shall provide Owner with in-progress Construction Documents as needed. At the completion of construction the CONTRACTOR shall supply record drawings, and a copy of the final Construction Documents on a re-recordable compact disk.

3.3.1.4 CONTRACTOR shall file all documents required for the approval of the Project through the City of Ashland Building Division and Fire Department.

3.3.2 All specified items shall be standard, cataloged, manufactured items or “off the shelf” items.

3.3.3 Recycled products shall be used where they are economically feasible. The CONTRACTOR shall give preference to materials and supplies manufactured from recycled materials under the following conditions:

- a) The recycled product is available;
- b) The recycled product meets applicable standards;
- c) The recycled product can be substituted for a comparable non-recycled product; and
- d) Recycled product costs do not exceed the costs of non-recycled products by more than five percent.

3.4 Construction Administration Services

3.4.1 GENERAL OFFICE CONSTRUCTION ADMINISTRATION.

CONTRACTOR shall process submittals, including without limitation, the receipt, review and disposition of shop drawings, product data, and samples. CONTRACTOR shall transmit any such submittals to Owner, as required and shall maintain a master file of submittal communications. CONTRACTOR shall keep a submittal log on a spreadsheet program and send a copy to the Owner on a weekly basis.

3.4.2 INSPECTION COORDINATION. CONTRACTOR shall provide all necessary services relating to independent inspection and testing required by applicable regulatory agencies, or relating to other inspection, testing of the systems and equipment installed on the Project site as part of the Work, including but not limited to the following: administration and coordination of field testing as required by the Contract Documents; establishing the scope, standards, procedures and frequency of testing and inspections required to complete the Work; arranging for testing and inspections; notifying inspection and testing agencies of status of any portion of the Work requiring

testing and inspection; evaluating compliance by testing and inspection agencies with required scope, standards, procedures and frequency; review of reports on inspections and tests; notifying the Owner of any observed deficiencies in the Work; and, providing copies of all reports on inspections and tests, as well as copies of all correspondence from the testing and inspection agencies, to the Owner.

- 3.4.3 SUPPLEMENTAL DOCUMENTS.** CONTRACTOR shall prepare, reproduce and distribute supplemental drawings, Plans and Specifications and shall issue interpretations in response to requests for clarification by Owner's Project Manager, or sub-contractors or as required by construction exigencies. CONTRACTOR shall be responsible for notifying the appropriate parties of Owner's instructions and of changed requirements and schedule revisions.
- 3.4.4 CHANGE REQUESTS/CHANGE ORDERS.** With respect to Change Requests and Change Orders requested or approved by the Owner, CONTRACTOR shall prepare, reproduce and distribute drawings, Plans and Specifications to describe Work to be added, deleted or modified; review proposals from sub-contractor(s) for reasonableness of quantities and costs of labor and materials; review and recommend changes in time for substantial completion; coordinate communications, approvals and notifications. CONTRACTOR shall keep a log of all change requests on a spreadsheet program and copy the Owner bi-weekly.
- 3.4.5 PAYMENT REVIEW.** CONTRACTOR shall evaluate and certify applications for payment and shall maintain detailed records supporting approved applications for payment.
- 3.4.6 PROJECT CLOSEOUT.** CONTRACTOR shall verify that Work is sufficiently complete, in accordance with the Contract Documents, to permit occupancy or utilization for the use for which it is intended. CONTRACTOR shall coordinate a detailed inspection with the OPM to ensure that the Work conforms to the Contract Documents; to verify the list submitted by the sub-contractor(s) of items to be completed or corrected; to determine the amounts to be withheld until Final Completion; to issue Certificates of Substantial Completion; to perform inspection(s) upon notice by the sub-contractor(s) that the Work is ready for final inspection and acceptance; to notify Owner and sub-contractor(s) of deficiencies found in follow-up inspection(s), if any; to perform final inspection with the Owner's representative to verify Final Completion of the Work; to receive and transmit warranties, affidavits, receipts, releases and waivers of lien or bonds indemnifying the Owner against liens; and to issue Final Certificate(s) for Payment.
- 3.4.7 RECORD DRAWINGS.** CONTRACTOR shall provide Design Services consisting of: preparation of record drawings on reproducible mylar, and on a re-recordable compact disk, based on information furnished by the sub-contractor(s) including significant changes in the Work made during

construction including modifying the floor plan layouts including partitions, furniture and equipment; transmittal of record drawings and general data, appropriately identified, to the Owner and others as directed.

3.4.8 **WARRANTY REVIEW.** One month prior to the expiration of the warranties of any sub-contractor(s) and manufacturer(s), the CONTRACTOR shall perform a warranty review, documenting defects or deficiencies in installation, materials, systems and equipment and preparing instructions to the sub-contractor(s) and manufacturer(s) for correction of noted defects. The CONTRACTOR shall then follow through to ensure that each defect or deficiency is appropriately addressed and verify that an appropriate remedy has been accomplished. The CONTRACTOR shall copy the Owner on the correspondence related to these warranty issues.

3.5 Construction Services/Construction Management Services.

3.5.1 CONTRACTOR shall have complete control over and charge of and shall be responsible for construction means, methods, techniques, sequences or procedures, and for safety precautions and programs in connection with the Work on the Project, so that, upon completion of the Work the Project shall be structurally sound and shall be a complete, fully-functioning facility suitable for the purposes for which it is intended. These roles are solely CONTRACTOR's responsibility under the Contract. CONTRACTOR shall be fully responsible for maintaining construction schedules and for any failure to carry out the Work in accordance with the Contract Documents. CONTRACTOR shall be deemed to have complete control over or charge of acts or omissions of all CONTRACTOR employees, agents, Design Professionals, and construction managers, as well as subcontractors, or their agents or employees, or of any other persons performing portions of the Work.

3.5.2 CONTRACTOR's responsibility to provide the Design Services and Construction Work under the Contract commences with the execution of this Agreement and terminates upon CONTRACTOR's satisfaction of all obligations set forth in the Contract including those enumerated at **Section K** of the OUS General Conditions.

3.5.3 CONTRACTOR shall provide, supervise and administer all Construction Work of the Contract as set forth in this Agreement and in the OUS General Conditions, unless otherwise provided in the Contract.

3.5.4 CONTRACTOR's duties, responsibilities and limitations of authority shall not be modified or extended without the express written agreement of the Parties and any required local or State of Oregon governmental approvals.

3.5.5 Except as may otherwise be provided in the Contract Documents or when direct communications have otherwise been specifically authorized, Owner shall conduct all communications concerning the Design Services and Construction Work through the CPM.

- 3.5.6** Subject to the right to suspend and terminate as provided in **Section J** of the OUS General Conditions, in no event shall the existence of any claim, dispute or question constitute a justification for either party to suspend or terminate the progress of the Work, and both parties, in such event, shall continue to prosecute the Work and perform under the Contract diligently, and shall resolve the claim, dispute or question either by agreement or mediation or other lawful means.
 - 3.5.7** At its own expense, CONTRACTOR shall correct Construction Work which does not conform to the Construction Documents.
 - 3.5.8** CONTRACTOR warrants to Owner that materials and equipment incorporated in the Construction Work will be new unless otherwise specified, and that the Construction Work will be of good quality, free from faults and defects, and in conformance with the Contract Documents. CONTRACTOR shall correct at its own expense work not conforming to these requirements in accordance with the terms of the Contract Documents.
 - 3.5.9** OWNER shall secure and pay for building and other permits and governmental fees, licenses and inspections necessary for the proper execution and completion of the Construction Work which are either customarily secured or are legally required.
- 3.6 Additional Services.** All other services requested by Owner and mutually agreed to in writing by Owner and CONTRACTOR, including, among others, changes in the Design Services or Construction Work described in this Agreement, shall constitute Additional Services and shall be paid by Owner as provided in the written agreement applicable thereto.

4. RELATIONSHIP BETWEEN AND ROLES OF THE PARTIES

4.1 Owner Responsibilities.

- 4.1.1** Owner shall designate a representative authorized to act on Owner's behalf with respect to the Project. Owner or such authorized representative shall examine documents submitted by CONTRACTOR and shall promptly render decisions pertaining thereto to avoid delay in the orderly progress of the Work. Owner shall render approval of formal submittals within ten (10) calendar days after receipt of submittals from CONTRACTOR.
- 4.1.2** If Owner observes or otherwise becomes aware of a fault or defect in the Work or nonconformity with the Design or Construction Documents, Owner shall give prompt written notice thereof to CONTRACTOR.
- 4.1.3** Owner shall furnish required information and services and shall promptly render decisions pertaining thereto to avoid delay in the orderly progress of the design and construction.
- 4.1.4** No approval or acceptance of Construction Documents or changes herein given by or on behalf of Owner shall establish any warranty or representation

on the part of Owner that such Construction Documents or changes are technically sound, complete or correct.

4.1.5 Owner shall communicate with the Design Professionals only through CONTRACTOR's Representative except in matters of public safety.

4.2 Independent Contractor. The CONTRACTOR is an independent Contractor and not an officer, employee, or agent of Owner as those terms are used in ORS 30.265.

4.3 CONTRACTOR's Key Personnel. The CONTRACTOR's project staff shall consist of the following personnel. The CONTRACTOR's personnel identified herein shall be considered unique, key personnel, and shall not be replaced during the Project without the written permission of Owner, which shall not be unreasonably withheld.

4.3.1 _____ (*complete*) shall be the CONTRACTOR's Principal-in-Charge.

4.3.2 _____ (*complete*) shall be the CPM and shall participate in all meetings throughout the Project term.

4.3.3 _____ (*complete*) shall be the CONTRACTOR's Design Professional(s) that will provide all Design Services provided for in the Contract.

4.3.4 _____ (*complete*) shall be the CONTRACTOR's on-site job superintendent for the Construction Work throughout the Project.

4.4 Design Builder's Consultants/Subcontractors. The CONTRACTOR shall be assisted by the consultants and/or subcontractors set forth in **Exhibit 5** hereto. The Parties acknowledge and agree that the Consultants have been reviewed and approved by the Owner, prior to the execution of this Agreement.

4.5 Replacement of CONTRACTOR's Project Team. If the CONTRACTOR intends to substitute Key Personnel, Consultants, or Subcontractors, a request must be given to Owner at least 10 days prior to the intended time of substitution. When Owner has approved replacements, the CONTRACTOR shall provide a transition period of at least 10 working days during which the original and replacement personnel shall be working on the Project concurrently, if feasible. Once a replacement for any Key Personnel, Consultants or Sub-contractors is authorized, further replacement shall not occur without the written permission of Owner.

5. COMPENSATION OF CONTRACTOR

Owner shall pay CONTRACTOR the Contract Price stated in Section 7 of this Agreement for all Design Services and Construction Work according to the provisions of **Section E** "Payments" of the OUS General Conditions on the dates listed below:

5.1 Design Services. Following execution of this Agreement, the CONTRACTOR shall submit its application for payment to Owner for Design Services performed during the prior month. Subject to the terms and conditions of Section E of the General

Conditions, Owner will make payment within 45 Days of receipt of an application for payment.

- 5.2 Construction Work. On the fifth (5th) of each month following commencement of Construction Work, the CONTRACTOR shall submit its application for payment to Owner in compliance with the terms and conditions of Section E of the OUS General Conditions. Owner will make payment to the CONTRACTOR, subject to the terms and conditions of Section E of the OUS General Conditions, within 45 Days of receipt of each application for payment. Owner shall withhold retainage in the amount of 5% from all payments relating to Construction Work, in accordance with the provisions of Subsection E.5 of the OUS General Conditions.

6. TERMINATION

- 6.1 **Parties Right to Terminate for Convenience.** The Contract may be terminated by written mutual consent of the parties.
- 6.2 **Owner's Right to Terminate for Convenience.** Owner may, in its sole discretion, terminate the Contract by written notice to CONTRACTOR specifying the termination date of the Contract. Should the Owner terminate the Contract for convenience by providing 15 days advance written notice thereof to CONTRACTOR, Owner shall pay to CONTRACTOR that sum equal to the percentage of the Work that is completed and accepted by Owner.
- 6.3 **Owner's Right to Terminate for Cause.** Owner may terminate the Contract, in whole or in part, immediately upon notice to CONTRACTOR, or such later date as Owner may establish in such notice, upon the occurrence of any of the following events:
- 6.3.1 Owner fails to receive funding, or appropriations, limitations or other expenditure authority at levels sufficient to pay for CONTRACTOR's services;
 - 6.3.2 Federal, state or local laws, regulations or guidelines are modified or interpreted in such a way that either the services under the Contract are prohibited or Owner is prohibited from paying for such services from the planned funding source;
 - 6.3.3 CONTRACTOR no longer holds a license or certificate that is required to perform the services;
 - 6.3.4 CONTRACTOR commits any material breach or default of any covenant, warranty, obligation or agreement under the Contract, fails to perform the Design Services or Construction Work under the Contract within the time specified herein or any extension thereof, or so fails to perform as to endanger CONTRACTOR's performance under the Contract in accordance with its terms, and such breach, default or failure is not cured within 10 calendar days after delivery of Owner's notice, or such longer period of cure as Owner may specify in such notice.
- 6.4 **Cessation of Work.** Upon receiving a notice of termination, and except as otherwise directed in writing by Owner, CONTRACTOR shall immediately cease all activities related to the Contract.

6.5 CONTRACTOR's Right to Terminate for Cause.

6.5.1 CONTRACTOR may terminate the Contract if Owner fails to pay CONTRACTOR pursuant to the terms of the Contract, provided that Owner does not cure its failure to make payment to CONTRACTOR within 15 calendar days after receiving written notice from CONTRACTOR of such failure to make payment.

6.5.2 CONTRACTOR may terminate the Contract, for reasons other than non-payment, if Owner commits any other material breach or default of the Contract, and fails to cure such breach or default within 30 calendar days after delivery of CONTRACTOR's notice, or such longer period as CONTRACTOR may specify in such notice.

7. CONTRACT PRICE

The "Contract Price," namely the total fixed cost of the Project for both Design Services and Construction Work payable under the Contract, unless increased or decreased by the price of approved change orders, is _____ (*complete*) as established by the CONTRACTOR in its Proposal, and includes the entire cost of all labor, materials, tools, equipment, Consultants' fees, transportation, components and systems, allowances, bonds and insurance premiums, incidentals, contingencies, and CONTRACTOR'S overhead and profit

8. CHANGES IN THE WORK. Adjustments to the Contract Price required by changes in the Design Services or Construction Work beyond the stated scope may be determined by any of the methods listed in **Section D** of the OUS General Conditions.

9. RESERVED.

10. INSURANCE PROVISIONS. During the term of this Agreement, Design/Builder shall maintain in full force, at its own expense, from companies licensed to do business in Oregon, each insurance coverage required by **Section G.3** of the OUS General Conditions, except as modified below:

10.1 Professional Liability/Errors & Omissions. Design/Builder shall provide the Owner with proof of coverage for Professional Liability/Errors & Omissions insurance covering any damages caused by any negligent error, omission, or any act for the Project, its drawings and specifications and all related work products of the Design/Builder. The policy may be either a practice based policy or a policy pertaining to the specific project. Professional Liability insurance to be provided shall have minimum limits of \$1,000,000 per occurrence and \$2,000,000 aggregate and name the State of Oregon acting by and through the Oregon State Board of Higher Education on behalf of Southern Oregon University, and their officers, agents and employees as an additional insured in such insurance policy.

11. GENERAL SUBCONTRACTING REQUIREMENTS.

11.1 CONTRACTOR's Obligations under Subcontracts.

- 11.11 No use of a Subcontractor or supplier shall relieve the CONTRACTOR of any of its obligations or liabilities under the Contract. Except as may expressly otherwise be provided in the Contract, the CONTRACTOR shall be fully responsible and liable for the acts or omissions of all Subcontractors and suppliers including persons directly or indirectly employed by them. The CONTRACTOR shall have sole responsibility for managing and coordinating the operations of its Subcontractors and suppliers, including the settlement of disputes with or between the CONTRACTOR and any such Subcontractor or supplier.
- 11.1.2 The CONTRACTOR shall include in each subcontract and require each Subcontractor to include in any lower tier subcontract, all provisions necessary to make all of the provisions of the Contract Documents, including the OUS General Conditions, fully effective as applied to Subcontractors. CONTRACTOR shall indemnify Owner for any additional cost based on a subcontractor claim which results from the failure of CONTRACTOR to incorporate the provisions of this Contract in each subcontract. The CONTRACTOR shall provide all necessary Plans, Specifications, and instructions to its suppliers and Subcontractors to enable them to properly perform their work.
- 11.1.3 Except with the Owner's prior approval, payments to Subcontractors shall be subject to retainage of no more than 5%. The Owner and the CONTRACTOR shall agree upon a mutually acceptable procedure for review and approval of payments and retainage for Subcontractors.

12. MISCELLANEOUS LABOR.

- 12.1** The CONTRACTOR may provide normal layout, clean up, and other "pick-up" work required to complete the Project with its own forces, without the necessity of subcontracting.

- 13. ACCOUNTING; AUDIT ACCESS.** The CONTRACTOR shall keep full and detailed accounts and exercise such controls as may be necessary for proper financial management under the Contract; the accounting and control systems shall be satisfactory to Owner. Owner and Owner's representatives, including the Oregon Secretary of State accountants and auditors, shall be afforded reasonable and regular access to the CONTRACTOR's records, books, correspondence, instructions, drawings, Plans, Specifications, receipts, subcontracts, purchase orders, vouchers, memoranda and other data relating to this Agreement, and the CONTRACTOR shall preserve these for a period of three years after final payment, or for such longer period as may be required by law. Owner may, at its discretion, perform periodic audits of the Cost of the Work and any other reimbursable costs associated with the Project. Owner intends to conduct a final audit of reimbursable costs prior to the Agreement closeout. The CONTRACTOR shall cooperate fully with Owner in the performance of such audits.

14. CONTRACT TIME

- 14.1 Date of Commencement.** The Design Services work shall commence within five days of the Contractor's receipt of Owner's Notice to Proceed ("Date of Commencement") unless the parties mutually agree otherwise in writing.
- 14.2 Substantial Completion.** Substantial Completion for the entire Construction Work shall be achieved no later than (complete) calendar days after the Date of Commencement.
- 14.3 Interim Substantial Completion.** Interim Substantial Completion of identified portions of the Construction Work shall be completed pursuant to **Section H** of the OUS General Conditions.
- 14.4 Final Completion of the Construction Work.** Final Completion of the Construction Work, or identified portions of the Construction Work, shall be achieved as expeditiously as practicable. All of the dates set forth in this **Section 16** ("Contract Times") shall be subject to adjustment in accordance with the OUS General Conditions.

15. INDEMNITY

- A. Claims for Other Than Professional Liability.** Contractor shall indemnify, hold harmless and defend the Owner and its colleges and universities and any public agencies for which Design Services and Construction Work are performed under this Agreement as supplemented or amended, and their officers, agents, employees and members from and against all claims, suits, actions, losses, damages, liabilities, costs and expenses of whatsoever nature resulting from, arising out of, or relating to the activities of the Contractor or the Contractor's Consultants, partners, joint venturers, subcontractors, officers, agents or employees acting under or pursuant to this Agreement or any supplement or amendment hereto.
- B. Claims for Professional Liability.** Contractor shall save, defend, indemnify and hold harmless the Owner and its colleges and universities and any public agencies for which Design Services are to be performed under this Agreement as supplemented or amended, and their officers, agents, employees and members from and against all claims, suits or actions, losses, damages, liabilities, costs and expenses of whatsoever nature resulting from, arising out of or relating to the professional negligent acts, errors or omissions of Contractor or its Consultants, partners, joint venturers, subcontractors, officers, agents or employees acting under or pursuant to this Agreement or any supplement or amendment hereto.
- C. Owner Defense Requirements.** Notwithstanding the foregoing defense obligations of the Contractor, neither the Contractor nor any attorney engaged by the Contractor shall defend any claim in the name of the Owner, the State of Oregon or any agency of the State of Oregon, nor purport to act as legal representative of the Owner, the State of Oregon or any of its agencies, without the prior written consent of the Oregon Attorney General. The Owner may, at anytime at its election assume its own defense and settlement in the event that it determines that the Contractor is prohibited from defending

the Owner, that Contractor is not adequately defending the Owner's interests, or that an important governmental principle is at issue or that it is in the best interests of the Owner to do so. The Owner reserves all rights to pursue any claims it may have against the Contractor if the Owner elects to assume its own defense.

D. Agency's Actions. Sub-sections A. and B. above do not include indemnification by the Contractor of the Owner for the Owner's activities, whether related to this Agreement or otherwise.

16. LIMITATION OF LIABILITIES

Except for any liability of the Contractor arising under or related to the Contractor's failure to perform according to the standard of care or any other liability arising under or related to the Contractor's representations and warranties under **Section 17** of this Agreement, neither Party shall be liable for any indirect, incidental, consequential or special damages under this Agreement or any damages of any sort arising solely from the termination of this Agreement in accordance with its terms.

17. CONTRACTOR'S STANDARD OF CARE; REPRESENTATIONS AND WARRANTIES

- A. Standard of Care.** By execution of this Agreement, the Contractor agrees to perform the Design Services in accordance with the professional skill, care and standards of other professionals performing similar services under similar conditions.
- B. Performance Requirements.** By execution of this Agreement, the Contractor specifically agrees to perform the Design Services in accordance with the following requirements:
1. All Plans, drawings, Specifications, and other documents prepared by the Contractor shall accurately reflect, incorporate and comply with all applicable statutes, rules, regulations, ordinances and other laws which are applicable to the design and construction of the Project, and shall be complete and functional for the purposes intended (except as to any deficiencies which are due to causes beyond the control of Contractor);
 2. All Plans, drawings, Specifications, and other documents prepared by the Contractor pursuant to this Agreement shall accurately reflect existing conditions for the scope of the Design Services to be performed;
 3. The Project, if constructed in accordance with the intent established by such Plans, drawings, Specifications, and other documents, shall be structurally sound and a complete and properly functioning facility suitable for the purposes for which it is intended;
 4. The Contractor shall be responsible for any negligent inconsistencies or omissions in the Plans, drawings, Specifications, and other documents. While Contractor

cannot guarantee that the various documents required under this Agreement are completely free of all minor human errors and omissions, it shall be the responsibility of Contractor throughout the period of performance under this Agreement to use due care and perform with professional competence. Contractor will, at no additional cost to Owner, correct any and all errors and omissions in the Plans, drawings, Specifications, and other documents prepared by Contractor. Contractor further agrees to render assistance to Owner in resolving other problems relating to the design of, or specified materials used in, the Project at no additional cost;

5. The Owner's review or acceptance of documents, or authorization to continue to the next phase of design, bidding process participation, or construction administration, shall not be deemed as approval of the adequacy of the Plans, drawings, Specifications, or other documents. Any review or acceptance by the Owner will not relieve the Contractor of any responsibility for complying with the standard of care set forth herein. The Contractor is responsible for all Design Services to be performed under this Agreement, and agrees that it will be liable for all its negligent acts, errors, or omissions, if any, relative to the Design Services.
6. The representations and warranties set forth in this Section are in addition to, and not in lieu of, any other representations or warranties provided.

C. Contractor's Representations and Warranties. Contractor represents and warrants to Owner that:

1. Contractor has the power and authority to enter into and perform this Agreement;
2. When executed and delivered, this Agreement shall be a valid and binding obligation of the Contractor enforceable in accordance with its terms;
3. Contractor shall, at all times during the term of this Agreement be duly licensed to perform the Design Services, and if there is no licensing requirement for the profession or services, be duly qualified and competent. Contractor must also be registered with the Oregon Construction Contractors Board and have on file with the Construction Contractors Board the required Public Works Bond.
4. The Contractor is an experienced Contractor firm having the skill, legal capacity, and professional ability necessary to perform all the Design Services required under this Agreement and to design or administer a project having this scope and complexity;
5. The Contractor has the capabilities and resources necessary to perform the obligations of this Agreement;
6. The Contractor either is, or in a manner consistent with the standard of care set forth in this Agreement will become, familiar with all current laws, rules, and regulations which are applicable to the design and construction of the Project.

18. COMPLIANCE WITH APPLICABLE LAW

Contractor agrees to comply with all federal, state, county, and local laws, ordinances, and regulations applicable to the Design Services and Construction Work to be provided under this Agreement. Contractor specifically agrees to comply with all applicable requirements of federal and state civil rights and rehabilitation statutes, rules and regulations. Contractor also shall comply with the Americans with Disabilities Act of 1990 (Pub L No. 101-336), ORS 659.425, and all regulations and administrative rules established pursuant to those laws. Failure or neglect on the part of Contractor to comply with any or all such laws, ordinances, rules, and regulations shall not relieve Contractor of these obligations nor of the requirements of this Agreement. Contractor further agrees to make payments promptly when due, to all persons supplying to such Contractor labor or materials for the performance of the Design Services and Construction Work to be provided under this Agreement; pay all contributions or amounts due the Industrial Accident Fund from such contractor incurred in the performance of this Agreement; not permit any lien or claim to be filed or prosecuted against the State on account of any labor or material furnished; and pay to the Department of Revenue all sums withheld from employees pursuant to ORS 316.167. If Contractor fails or refuses to make any such payments required herein, the appropriate Institution official may pay such claim. Any payment of a claim in the manner authorized in this Section shall not relieve the Contractor or Contractor's surety from obligation with respect to any unpaid claims. Section 504 of the Rehabilitation Act of 1973, the Americans with Disabilities Act and the Oregon Building Codes require all new construction to be totally accessible to people with physical limitations. Owner expects that all spaces in designs for new facilities and in remodel projects will be accessible to people with physical limitations.

19. GOVERNING LAW; VENUE; CONSENT TO JURISDICTION

This Agreement shall be governed by and construed in accordance with the laws of the State of Oregon without regard to principles of conflicts of law. Any claim, action, suit or proceeding (collectively "Claim") between Owner and Contractor that arises from or relates to this Agreement shall be brought and conducted solely and exclusively within the Circuit Court of Jackson County for the State of Oregon; provided, however, if a Claim must be brought in a federal forum, it shall be brought and conducted solely and exclusively within the United States District Court for the District of Oregon. In no event shall this Section be construed as a waiver by the State of Oregon of any form of defense or immunity, whether based on sovereign immunity, governmental immunity, immunity based on the Eleventh Amendment to the United States Constitution or otherwise. **CONTRACTOR, BY EXECUTION OF THIS AGREEMENT, HEREBY CONSENTS TO THE IN PERSONAM JURISDICTION OF SAID COURTS.**

20. ACCESS TO RECORDS

For not less than six (6) years after the termination or full performance of this Agreement, the Owner, the Secretary of State's Office of the State of Oregon, the federal government, and their duly authorized representatives shall have access to the books, documents, papers, and records of the Contractor and the Consultants which are directly pertinent to this Agreement for the purpose of making audit, examination, excerpts, and transcripts. If for any reason, any part of this Agreement, or any resulting construction contract(s) is involved in litigation,

Contractor shall retain all pertinent records for not less than three years or until all litigation is resolved, whichever is longer. The Contractor will provide full access to such documents in preparation for and during any such litigation.

21. SEVERABILITY

The Parties agree that if any term or provision of this Agreement is declared by a court of competent jurisdiction to be illegal or in conflict with any law, the validity of the remaining terms and provisions shall not be affected, and the rights and obligations of the Parties shall be construed and enforced as if the Agreement did not contain the particular term or provision held to be invalid.

22. FORCE MAJEURE

Neither party shall be held responsible for delay or default caused by fire, riot, acts of God, and war which is beyond such party's reasonable control. Each party shall, however, make all reasonable efforts to remove or eliminate such a cause of delay or default and shall, upon the cessation of the cause, diligently pursue performance of its obligations under this Agreement.

23. NO WAIVER

The failure of the Owner to enforce any provision of this Agreement shall not constitute a waiver by the Owner of that or any other provision.

24. NOTICE; PARTIES' REPRESENTATIVES

Except as otherwise expressly provided in this Agreement, any notices to be given hereunder shall be given in writing by personal delivery, facsimile, or mailing the same, postage prepaid, to Contractor or Owner at the address or number set forth below, or to such other addresses or numbers as either Party may hereafter indicate pursuant to this Section. Any notice so addressed and mailed shall be deemed to be given five (5) calendar days after the date of mailing. Any notice delivered by facsimile shall be deemed to be given when receipt of the transmission is generated by the transmitting machine. To be effective against Owner, such facsimile transmission must be confirmed by telephone notice to Owner's Representative named below. Any notice by personal delivery shall be deemed to be given when actually delivered. Regular, day-to-day communications between the Parties may be transmitted through one of the methods set forth above, in person, by telephone, by e-mail, or by other similar electronic transmission.

Representatives for the Contractor and the Owner for purposes of notice and for other specific purposes provided for under this Agreement are:

Contractor: _____ *(complete)*

Telephone: _____ *(complete)*

Address: _____ *(complete)*

Owner: _____ *(complete)*

25. CONFIDENTIALITY.

Contractor shall maintain the confidentiality of information of Owner, unless withholding such information would violate the law, create the risk of significant harm to the public or prevent Contractor from establishing a claim or defense in an adjudicatory proceeding. Contractor shall require the Consultants to execute similar agreements to maintain the confidentiality of information of Owner.

26. CONFLICT OF INTEREST.

Except with Owner's prior written consent, Contractor shall not engage in any activity or accept any employment, interest or contribution that would or would reasonably appear to compromise Contractor's professional judgment with respect to this Project, including without limitation, concurrent employment on any project in direct competition with the Project, and will provide copies of any such agreements within ten (10) days of the full execution of such agreements.

27. MERGER CLAUSE

THIS AGREEMENT AND ANY ATTACHED EXHIBITS CONSTITUTE THE ENTIRE AGREEMENT BETWEEN THE PARTIES ON THE SUBJECT MATTER HEREOF. THERE ARE NO UNDERSTANDINGS, AGREEMENTS, OR REPRESENTATIONS, ORAL OR WRITTEN, NOT SPECIFIED HEREIN REGARDING THIS AGREEMENT. NO AMENDMENT, CONSENT, OR WAIVER OF TERMS OF THIS AGREEMENT SHALL BIND EITHER PARTY UNLESS IN WRITING AND SIGNED BY ALL PARTIES. ANY SUCH AMENDMENT, CONSENT, OR WAIVER SHALL BE EFFECTIVE ONLY IN THE SPECIFIED INSTANCE AND FOR THE SPECIFIC PURPOSE GIVEN. CONTRACTOR, BY THE SIGNATURE BELOW OF ITS AUTHORIZED REPRESENTATIVE, ACKNOWLEDGES HAVING READ AND UNDERSTOOD THIS AGREEMENT AND THE CONTRACTOR AGREES TO BE BOUND BY ITS TERMS AND CONDITIONS.

IN WITNESS WHEREOF, and intending to be legally bound, the authorized representatives of the parties hereto subscribe their names.

CONTRACTOR

STATE OF OREGON ACTING BY AND
THROUGH THE STATE BOARD OF HIGHER
on behalf of Southern Oregon University

By _____

By _____
Craig Morris

Title _____

Title **Vice President, Finance and Administration**

Date _____

Date _____

Federal I.D. #: _____

Approved for Legal Sufficiency
Department of Justice

Assistant Attorney General

Date

TABLE OF EXHIBITS

EXHIBITS

- Exhibit 1 Oregon University System General Conditions for Public Improvement Contracts
- Exhibit 2 OUS Supplemental General Conditions
- Exhibit 3 SOU Request for Proposal 2014-0327
- Exhibit 4 SOU Addendums _____ (*complete*), issued on dates _____ (*complete*)
- Exhibit 5 Contractor's Proposal dated _____ (*complete*)

OREGON UNIVERSITY SYSTEM

GENERAL CONDITIONS FOR PUBLIC IMPROVEMENT CONTRACTS

July 1, 2012

INSTRUCTIONS: The attached **Oregon University System General Conditions for Public Improvement Contracts** ("OUS Public Improvement General Conditions") apply to all designated public improvement contracts. Changes to the OUS Public Improvement General Conditions (including any additions, deletions or substitutions) should only be made by attaching Public Improvement Supplemental General Conditions. The text of these OUS Public Improvement General Conditions should not otherwise be altered.

TABLE OF SECTIONS

SECTION A **GENERAL PROVISIONS**

- A.1 DEFINITION OF TERMS
- A.2 SCOPE OF WORK
- A.3 INTERPRETATION OF CONTRACT DOCUMENTS
- A.4 EXAMINATION OF PLANS, SPECIFICATIONS, AND SITE
- A.5 INDEPENDENT CONTRACTOR STATUS
- A.6 RETIREMENT SYSTEM STATUS AND TAXES
- A.7 GOVERNMENT EMPLOYMENT STATUS

SECTION B **ADMINISTRATION OF THE CONTRACT**

- B.1 OWNER'S ADMINISTRATION OF THE CONTRACT
- B.2 CONTRACTOR'S MEANS AND METHODS
- B.3 MATERIALS AND WORKMANSHIP
- B.4 PERMITS
- B.5 COMPLIANCE WITH GOVERNMENT REGULATIONS
- B.6 SUPERINTENDENCE
- B.7 INSPECTION
- B.8 SEVERABILITY
- B.9 ACCESS TO RECORDS
- B.10 WAIVER
- B.11 SUBCONTRACTS AND ASSIGNMENT
- B.12 SUCCESSORS IN INTEREST
- B.13 OWNER'S RIGHT TO DO WORK
- B.14 OTHER CONTRACTS
- B.15 GOVERNING LAW
- B.16 LITIGATION
- B.17 ALLOWANCES
- B.18 SUBMITTALS, SHOP DRAWINGS, PRODUCT DATA, AND SAMPLES
- B.19 SUBSTITUTIONS
- B.20 USE OF PLANS AND SPECIFICATIONS
- B.21 FUNDS AVAILABLE AND AUTHORIZED
- B.22 NO THIRD PARTY BENEFICIARIES

SECTION C **WAGES AND LABOR**

- C.1 MINIMUM WAGES RATES ON PUBLIC WORKS
- C.2 PAYROLL CERTIFICATION AND FEE REQUIREMENTS, ADDITIONAL RETAINAGE
- C.3 PROMPT PAYMENT AND CONTRACT CONDITIONS
- C.4 PAYMENT FOR MEDICAL CARE
- C.5 HOURS OF LABOR

SECTION D **CHANGES IN THE WORK**

- D.1 CHANGES IN THE WORK
- D.2 DELAYS
- D.3 CLAIMS REVIEW PROCESS

SECTION E
PAYMENTS

- E.1 SCHEDULE OF VALUES
- E.2 APPLICATIONS FOR PAYMENT
- E.3 PAYROLL CERTIFICATION REQUIREMENT
- E.4 DUAL PAYMENT SOURCES
- E.5 RETAINAGE
- E.6 FINAL PAYMENT

SECTION F
JOB SITE CONDITIONS

- F.1 USE OF PREMISES
- F.2 PROTECTION OF WORKERS, PROPERTY, AND THE PUBLIC
- F.3 CUTTING AND PATCHING
- F.4 CLEANING UP
- F.5 ENVIRONMENTAL CONTAMINATION
- F.6 ENVIRONMENTAL CLEAN-UP
- F.7 FORCE MAJEURE

SECTION G
INDEMNITY, BONDING AND INSURANCE

- G.1 RESPONSIBILITY FOR DAMAGES/INDEMNITY
- G.2 PERFORMANCE AND PAYMENT SECURITY, PUBLIC WORKS BOND
- G.3 INSURANCE

SECTION H
SCHEDULE OF WORK

- H.1 CONTRACT PERIOD
- H.2 SCHEDULE
- H.3 PARTIAL OCCUPANCY OR USE

SECTION I
CORRECTION OF WORK

- I.1 CORRECTIONS OF WORK BEFORE FINAL PAYMENT
- I.2 WARRANTY WORK

SECTION J
SUSPENSION AND/OR TERMINATION OF THE WORK

- J.1 OWNER'S RIGHT TO SUSPEND THE WORK
- J.2 CONTRACTOR'S RESPONSIBILITIES
- J.3 COMPENSATION FOR SUSPENSION
- J.4 OWNER'S RIGHT TO TERMINATE CONTRACT
- J.5 TERMINATION FOR CONVENIENCE
- J.6 ACTION UPON TERMINATION

SECTION K
CONTRACT CLOSE-OUT

- K.1 RECORD DOCUMENTS
- K.2 OPERATION AND MAINTENANCE MANUALS
- K.3 COMPLETION NOTICES
- K.4 TRAINING
- K.5 EXTRA MATERIALS
- K.6 ENVIRONMENTAL CLEAN-UP
- K.7 CERTIFICATE OF OCCUPANCY
- K.8 OTHER CONTRACTOR RESPONSIBILITIES
- K.9 SURVIVAL

**OREGON UNIVERSITY SYSTEM
GENERAL CONDITIONS FOR PUBLIC IMPROVEMENT CONTRACTS
("OUS Public Improvement General Conditions")**

**SECTION A
GENERAL PROVISIONS**

A.1 DEFINITION OF TERMS

In the Contract Documents the following terms shall be as defined below:

APPLICABLE LAWS, means federal, state and local laws, codes, rules, regulations and ordinances applicable to the Work and to the Contract.

ARCHITECT/ENGINEER, means the Person appointed by the Owner to make drawings and specifications and, to provide contract administration of the Work contemplated by the Contract to the extent provided herein or by supplemental instruction of Owner (under which Owner may delegate responsibilities to the Architect/Engineer), in accordance with ORS Chapter 671 (Architects) or ORS Chapter 672 (Engineers) and administrative rules adopted thereunder.

BID, means an offer binding on the Bidder and submitted in response to an Instructions to Bidders or a proposal in connection with a Request for Proposals.

BIDDER, means an Entity that submits a Bid in response to Instructions to Bidders or a proposer in connection with a Request for Proposals.

CHANGE ORDER, means a written order which, when fully executed by the Parties to this Contract, constitutes a change to the Contract Documents. Change Orders shall be issued in accordance with the changes provisions in Section D and, if applicable, establish a Contract Price or Contract Time adjustment. A Change Order shall not be effective until executed as a Change Order.

CLAIM, means a demand by Contractor pursuant to Section D.3 for review of the denial of Contractor's initial request for an adjustment of Contract terms, payment of money, extension of Contract Time or other relief, submitted in accordance with the requirements and within the time limits established for review of Claims in these OUS Public Improvement General Conditions.

CONSTRUCTION CHANGE DIRECTIVE, means a written order by the Owner to the Contractor requiring a change in the Work within the general scope of the Contract Documents, issued under the changes provisions of Section D.

CONTRACT, means the written agreement between the Owner and the Contractor comprised of the Contract Documents which describe the Work to be done and the obligations between the parties.

CONTRACT DOCUMENTS, means the Solicitation Document and addenda thereto, Instructions to Bidders, Supplemental Instructions to Bidders, the OUS Public Improvement Contract, OUS Public Improvement General Conditions, Public Improvement Supplemental General Conditions, if any, the accepted Bid, Plans, Specifications, Change Orders, and Construction Change Directives.

CONTRACT PERIOD, as set forth in the Contract Documents, means the total period of time beginning with the full execution of this Contract and, if applicable, the issuance of a Notice to Proceed and concluding upon Final Completion.

CONTRACT PRICE, means the total of the awarded Bid amount, as increased or decreased by the price of approved alternates, as indicated in the Contract Documents.

CONTRACT TIME, means any incremental period of time allowed

under the Contract to complete any portion of the Work as reflected in the project schedule.

CONTRACTOR, means the Person awarded the Contract for the Work contemplated.

DAYS, are calendar days, including weekdays, weekends and holidays, unless otherwise specified.

DIRECT COSTS, means, unless otherwise provided in the Contract Documents, the cost of materials, including sales tax, cost of delivery; cost of labor, including social security, Medicare and unemployment insurance, and fringe benefits required by agreement or custom; worker's compensation insurance; project specific insurance (including, without limitation, Builder's Risk Insurance and Builder's Risk Installation Floater); bond premiums, rental cost of equipment, and machinery required for execution of the Work; Owner's costs to correct defective Work; and the additional costs of field personnel directly attributable to the Work.

FINAL COMPLETION, means the final completion of all requirements under the Contract, including Contract Closeout as described in Section K but excluding Warranty Work as described in Section I.2, and the final payment and release of all retainage, if any, released.

FORCE MAJEURE, means an act, event or occurrence caused by fire, riot, war, acts of God, nature, sovereign, or public enemy, strikes, freight embargoes or any other act, event or occurrence that is beyond the control of the party to this Contract who is asserting Force Majeure.

MWESB REPORT, means an accurate report by the Contractor to the Owner identifying all Minority, Women and Emerging Small Business (MWESB) enterprises, as those terms are defined in ORS 200.005, receiving contracts throughout the course of the Work. An initial MWESB report is required (see Section E.2.9) and MWESB Reports are required annually (see Section E.2.9) and as a condition of final payment (see Section K.1). The initial report shall be in the form required by OUS and as posted from time to time on the OUS website and shall include the total number of contracts and subcontracts awarded to MWESB enterprises and the dollar value of their respective contracts and subcontracts. The annual reports shall include the total number of contracts and subcontracts awarded to MWESB enterprises, the dollar value of each, and the expenditure toward each contract and subcontract during the previous twelve (12) months. The final report shall include the total number of contracts and subcontracts awarded to MWESB enterprises and the dollar value of their respective contracts and subcontracts including all Change Orders incorporated during the course of the project. The reports shall only include enterprises certified with the State of Oregon as MWESB enterprises and shall include individual identification of each enterprise as a Minority business enterprise, a Women business enterprise, and/or an Emerging Small Business Enterprise, as applicable.

NOTICE TO PROCEED, means the official written notice from the Owner stating that the Contractor is to proceed with the Work defined in the Contract Documents. Notwithstanding the Notice to Proceed, Contractor shall not be authorized to proceed with the Work until all initial Contract requirements, including the Contract, performance bond and payment bond, and certificates of insurance, have been fully executed and submitted to Owner in a suitable form.

OVERHEAD, means those items which may be included in the Contractor's markup (general and administrative expense and profit) and that shall not be charged as Direct Cost of the Work,

including without limitation such Overhead expenses as wages or salary of personnel above the level of foreman (i.e., superintendents and project managers), expenses of Contractor's offices and supplies at the job site (e.g. job trailer) and at Contractor's principal place of business and including expenses of personnel staffing the job site office and Contractor's principal place of business, and Commercial General Liability Insurance and Automobile Liability Insurance.

OWNER, means the State of Oregon acting by and through the Oregon State Board of Higher Education, in its own right or on behalf of one of its institutions as identified in the Solicitation Document, also known as the Oregon University System (OUS). Owner may elect, by written notice to Contractor, to delegate certain duties to more than one party, including without limitation, to an Architect/Engineer. However, nothing in these OUS Public Improvement General Conditions is intended to abrogate the separate design professional responsibilities of Architects under ORS Chapter 671 or of Engineers under ORS Chapter 672.

PERSON, means a natural person or entity doing business as a sole proprietorship, a partnership, a joint venture, a corporation, a limited liability company or partnership, or any other entity possessing the legal capacity to contract.

PLANS, means the drawings which show the location, type, dimensions, and details of the Work to be done under the Contract.

PUNCH LIST, means the list of Work yet to be completed or deficiencies which need to be corrected in order to achieve Final Completion of the Contract.

RECORD DOCUMENT, means the as-built Plans, Specifications, testing and inspection records, product data, samples, manufacturer and distributor/supplier warranties evidencing transfer of ownership to Owner, operational and maintenance manuals, shop drawings, Construction Change Directives, MWESB Reports, correspondence, certificate(s) of occupancy, and other documents listed in Subsection B.9.1 of these OUS Public Improvement General Conditions, recording all Services performed.

SOLICITATION DOCUMENT, means Instructions to Bidders or Bidders or a Request for Proposal or a Request for Quotes.

SPECIFICATION, means any description of the physical or functional characteristics of the Work, or of the nature of a supply, service or construction item. Specifications may include a description of any requirement for inspecting, testing or preparing a supply, service or construction item for delivery and the quantities or qualities of materials to be furnished under the Contract. Specifications generally will state the results or products to be obtained and may, on occasion, describe the method and manner of doing the Work to be performed. Specifications may be incorporated by reference and/or may be attached to the Contract.

SUBCONTRACTOR, means a Person having a direct contract with the Contractor, or another Subcontractor, to perform one or more items of the Work.

SUBSTANTIAL COMPLETION, means the date when the Owner accepts in writing the construction, alteration or repair of the improvement to real property constituting the Work or any designated portion thereof as having reached that state of completion when it may be used or occupied for its intended purpose. Substantial Completion of facilities with operating systems occurs only after thirty (30) continuous Days of successful, trouble-free operation of the operating systems as provided in Section K.4.2.

SUBSTITUTIONS, means items that in function, performance, reliability, quality, and general configuration are the same or better than the product(s) specified. Approval of any substitute item shall be solely determined by the Owner. The decision of the Owner is final.

PUBLIC IMPROVEMENT SUPPLEMENTAL GENERAL CONDITIONS, means those conditions that remove from, add to, or modify these OUS Public Improvement General Conditions. Public Improvement Supplemental General Conditions may be included in the Solicitation Document or may be a separate attachment to the Contract.

WORK, means the furnishing of all materials, equipment, labor, transportation, services and incidentals necessary to successfully complete any individual item or the entire Contract and the carrying out of duties and obligations imposed by the Contract Documents.

A.2 SCOPE OF WORK

The Work contemplated under this Contract includes all labor, materials, transportation, equipment and services for, and incidental to, the completion of all construction work in connection with the project described in the Contract Documents. The Contractor shall perform all Work necessary so that the project can be legally occupied and fully used for the intended use as set forth in the Contract Documents.

A.3 INTERPRETATION OF CONTRACT DOCUMENTS

- A.3.1 Unless otherwise specifically defined in the Contract Documents, words which have well-known technical meanings or construction industry meanings are used in the Contract Documents in accordance with such recognized meanings. Contract Documents are intended to be complementary. Whatever is called for in one, is interpreted to be called for in all. However, in the event of conflicts or discrepancies among the Contract Documents, interpretations will be based on the following descending order of precedence:
- (a) Contract Change Orders and Construction Change Directives, with those of later date having precedence over those of an earlier date;
 - (b) The Public Improvement Supplemental General Conditions;
 - (c) The OUS Public Improvement Contract;
 - (d) The OUS Public Improvement General Conditions;
 - (e) Division One (General Requirements) of the Specifications;
 - (f) Detailed Schedules of finishes, equipment and other items included in the Specifications;
 - (g) Plans and Specifications (other than Division One and the Detailed Schedules to the Specifications);
 - (h) Large-scale drawings on Plans;
 - (i) Small-scale drawings on Plans;
 - (j) Dimension numbers written on Plans which shall prevail and take precedence over dimensions scaled from Plans;
 - (k) The Solicitation Document, and any addenda thereto;
 - (l) The accepted Bid.
- A.3.2 In the case of an inconsistency between Plans and Specifications or within either document not clarified by addendum, the better quality or greater quantity of Work shall be provided in accordance with the Owner's interpretation in writing.
- A.3.3 If the Contractor finds discrepancies in, or omissions from the Contract Documents, or if the Contractor is in doubt as to their meaning, the Contractor shall at once notify the Owner. Matters concerning and interpretation of requirements of the Contract Documents will be decided by the Owner, who may delegate that duty in some instances to the Architect/Engineer. Responses to Contractor's requests for interpretation of Contract

Documents will be made in writing by Owner (or the Architect/Engineer) within any time limits agreed upon or otherwise with reasonable promptness. Interpretations and decisions of the Owner (or Architect/Engineer) will be consistent with the intent of and reasonably inferable from the Contract Documents. Contractor shall not proceed without direction in writing from the Owner (or Architect/Engineer).

- A.3.4 References to standard specifications, manuals, codes of any technical society, organization or association, to the laws or regulations of any governmental authority, whether such reference be specific or by implication, shall mean the latest standard specification, manual, code, laws or regulations in effect in the jurisdiction where the project is occurring on the first published date of the Solicitation Document, except as may be otherwise specifically stated.

A.4 EXAMINATION OF PLANS, SPECIFICATIONS, AND SITE

- A.4.1 It is understood that the Contractor, before submitting a Bid, has made a careful examination of the Contract Documents; has become fully informed as to the quality and quantity of materials and the character of the Work required; and has made a careful examination of the location and conditions of the Work and the sources of supply for materials. The Owner will in no case be responsible for any loss or for any unanticipated costs that may be suffered by the Contractor as a result of the Contractor's failure to acquire full information in advance in regard to all conditions pertaining to the Work. No oral agreement or conversation with any officer, agent, or personnel of the Owner, or with the Architect/Engineer either before or after the execution of this Contract, shall affect or modify any of the terms or obligations herein contained.
- A.4.2 Should the Plans or Specifications fail to particularly describe the materials, kind of goods, or details of construction of any aspect of the Work, Contractor shall have the duty to make inquiry of the Owner and Architect/Engineer as to what is required prior to performance of the Work. Absent Specifications to the contrary, the materials or processes that would normally be used to produce first quality finished Work shall be considered a part of the Contract requirements.
- A.4.3 Any design errors or omissions noted by the Contractor shall be reported promptly to the Owner, including without limitation, any nonconformity with Applicable Laws.
- A.4.4 If the Contractor believes that adjustments to cost or Contract Time is involved because of clarifications or instructions issued by the Owner (or Architect/Engineer) in response to the Contractor's notices or requests for information, the Contractor must submit a written request to the Owner, setting forth the nature and specific extent of the request, including all time and cost impacts against the Contract as soon as possible, but no later than thirty (30) Days after receipt by Contractor of the clarifications or instructions issued. If the Owner denies Contractor's request for additional compensation, additional Contract Time, or other relief that Contractor believes results from the clarifications or instructions, the Contractor may proceed to file a Claim under Section D.3, Claims Review Process. If the Contractor fails to perform the obligations of Sections A.4.1 to A.4.3, the Contractor shall pay such costs and damages to the Owner as would have been avoided if the Contractor had performed such obligations.

A.5 INDEPENDENT CONTRACTOR STATUS

The service or services to be performed under this Contract are those of an independent contractor as defined in ORS 670.600. Contractor represents and warrants that it is not an officer, employee or agent of the Owner as those terms are used in ORS 30.265.

A.6 RETIREMENT SYSTEM STATUS AND TAXES

Contractor represents and warrants that it is not a contributing member of the Public Employees' Retirement System and will be responsible for any federal or state taxes applicable to payment received under this Contract. Contractor will not be eligible for any benefits from these Contract payments of federal Social Security, employment insurance, workers' compensation or the Public Employees' Retirement System, except as a self-employed individual. Unless the Contractor is subject to backup withholding, Owner will not withhold from such payments any amount(s) to cover Contractor's federal or state tax obligations.

A.7 GOVERNMENT EMPLOYMENT STATUS

- A.7.1 If this payment is to be charged against federal funds, Contractor represents and warrants that it is not currently employed by the Federal Government. This does not preclude the Contractor from holding another contract with the Federal Government.
- A.7.2 Contractor represents and warrants that Contractor is not an employee of the State of Oregon for purposes of performing Work under this Contract.

SECTION B ADMINISTRATION OF THE CONTRACT

B.1 OWNER'S ADMINISTRATION OF THE CONTRACT

- B.1.1 The Owner shall administer the Contract as described in the Contract Documents (1) during construction (2) until final payment is due and (3) during the one-year period for correction of Work. The Owner will act as provided in the Contract Documents, unless modified in writing in accordance with other provisions of the Contract. In performing these tasks, the Owner may rely on the Architect/Engineer or other consultants to perform some or all of these tasks.
- B.1.2 The Owner will visit the site at intervals appropriate to the stage of the Contractor's operations (1) to become generally familiar with and to keep the Owner informed about the progress and quality of the portion of the Work completed, (2) to endeavor to guard the Owner against defects and deficiencies in the Work, and (3) to determine in general if Work is being performed in a manner indicating that the Work, when fully completed, will be in accordance with the Contract Documents. The Owner will not make exhaustive or continuous on-site inspections to check the quality or quantity of the Work. The Owner will neither have control over or charge of, nor be responsible for the construction means, methods, techniques, sequences or procedures, or for the safety precautions and programs in connection with the Work.
- B.1.3 Except as otherwise provided in the Contract Documents or when direct communications have been specifically authorized, the Owner and Contractor shall communicate with each other about matters arising out of or relating to the Contract. Communications by and with the Architect/Engineer's consultants shall be through the Architect/Engineer. Communications by and with Subcontractors and material suppliers shall be through the Contractor. Communications by and with separate contractors shall be through the Owner.
- B.1.4 Based upon the Architect/Engineer's evaluations of the Contractor's Application for Payment, or unless otherwise stipulated by the Owner, the Architect/Engineer will review and certify the amounts due the Contractor and will issue Certificates for Payment in such amounts.

B.2 CONTRACTOR'S MEANS AND METHODS; MITIGATION OF IMPACTS

B.2.1 The Contractor shall supervise and direct the Work, using the Contractor's best skill and attention. The Contractor shall be solely responsible for and have control over construction means, methods, techniques, sequences and procedures and for coordinating all portions of the Work under the Contract, unless the Contract Documents give other specific instructions concerning these matters. If the Contract Documents give specific instructions concerning construction means, methods, techniques, sequences or procedures, the Contractor shall evaluate the jobsite safety thereof and, except as stated below, shall be fully and solely responsible for the jobsite safety of such means, methods, techniques, sequences or procedures.

B.2.2 The Contractor is responsible to protect and maintain the Work during the course of construction and to mitigate any adverse impacts to the project, including those caused by authorized changes, which may affect cost, schedule, or quality.

B.2.3 The Contractor is responsible for the actions of all its personnel, laborers, suppliers, and Subcontractors on the project. The Contractor shall enforce strict discipline and good order among Contractor's employees and other persons carrying out the Work. The Contractor shall not permit employment of persons who are unfit or unskilled for the tasks assigned to them.

B.3 MATERIALS AND WORKMANSHIP

B.3.1 The intent of the Contract Documents is to provide for the construction and completion in every detail of the Work described. All Work shall be performed in a professional manner and unless the means or methods of performing a task are specified elsewhere in the Contract Documents, Contractor shall employ methods that are generally accepted and used by the industry, in accordance with industry standards.

B.3.2 The Contractor is responsible to perform the Work as required by the Contract Documents. Defective Work shall be corrected at the Contractor's expense.

B.3.3 Work done and materials furnished shall be subject to inspection and/or observation and testing by the Owner to determine if they conform to the Contract Documents. Inspection of the Work by the Owner does not relieve the Contractor of responsibility for the Work in accordance with the Contract Documents.

B.3.4 Contractor shall furnish adequate facilities, as required, for the Owner to have safe access to the Work including without limitation walkways, railings, ladders, tunnels, and platforms. Producers, suppliers, and fabricators shall also provide proper facilities and access to their facilities.

B.3.5 The Contractor shall furnish Samples of materials for testing by the Owner and include the cost of the Samples in the Contract Price.

B.4 PERMITS

Except to the extent otherwise directed by Owner, Contractor shall obtain and pay for all necessary permits, licenses and fees, except for those specifically excluded in the Public Improvement Supplemental General Conditions, for the construction of the Work, for temporary obstructions, enclosures, opening of streets for pipes, walls, utilities, environmental Work, etc., as required for the project. Contractor shall be responsible for all violations of the law, in connection with the construction or caused by obstructing streets, sidewalks or otherwise. Contractor shall give all requisite notices to public authorities.

B.5 COMPLIANCE WITH GOVERNMENT REGULATIONS

B.5.1 Contractor shall comply with Applicable Laws pertaining to the Work and the Contract. Failure to comply with such

requirements shall constitute a breach of Contract and shall be grounds for Contract termination. Without limiting the generality of the foregoing, Contractor expressly agrees to comply with the following, as applicable:

(i) Title VI and VII of Civil Rights Act of 1964, as amended; (ii) Section 503 and 504 of the Rehabilitation Act of 1973, as amended; (iii) the Health Insurance Portability and Accountability Act of 1996; (iv) the Americans with Disabilities Act of 1990, as amended; (v) ORS Chapter 659A; as amended; (vi) all regulations and administrative rules established pursuant to the foregoing laws; and (vii) all other applicable requirements of federal and state civil rights and rehabilitation statutes, rules and regulations.

B.5.2 Contractor shall comply with all applicable requirements of federal and state civil rights and rehabilitation statutes, rules and regulations, and

(a) Contractor shall not discriminate against Disadvantaged, Minority, Women or Emerging Small Business enterprises, as those terms are defined in ORS 200.005, or a business enterprise that is owned or controlled by or that employs a disabled veteran, as that term is defined in ORS 408.225, in the awarding of subcontracts.

(b) Contractor shall maintain, in current and valid form, all licenses and certificates required by Applicable Laws or this Contract when performing the Work.

B.5.3 Unless contrary to federal law, Contractor shall certify that it shall not accept a bid from Subcontractors to perform Work as described in ORS 701.005 under this Contract unless such Subcontractors are registered with the Construction Contractors Board in accordance with ORS 701.035 to 701.055 at the time they submit their bids to the Contractor.

B.5.4 Unless contrary to federal law, Contractor shall certify that each landscape contractor, as defined in ORS 671.520(2), performing Work under this Contract holds a valid landscape contractor's license issued pursuant to ORS 671.560.

B.5.5 The following notice is applicable to Contractors who perform excavation Work. "ATTENTION: Oregon law requires you to follow rules adopted by the Oregon Utility Notification Center. Those rules are set forth in OAR 952-001-0010 through OAR 952-001-0090. You may obtain copies of the rules by calling the center at (503)232-1987."

B.5.6 Failure to comply with any or all of the requirements of B.5.1 through B.5.5 shall be a breach of Contract and constitute grounds for Contract termination. Damages or costs resulting from such noncompliance shall be the responsibility of Contractor.

B.6 SUPERINTENDENCE

Contractor shall keep on the site, during the progress of the Work, a competent superintendent and any necessary assistants who shall be satisfactory to the Owner and who shall represent the Contractor on the site. Directions given to the superintendent by the Owner shall be confirmed in writing to the Contractor.

B.7 INSPECTION

B.7.1 Owner shall have access to the Work at all times.

B.7.2 Inspection of the Work will be made by the Owner at its discretion. The Owner will have authority to reject Work that does not conform to the Contract Documents. Any Work found to be not in conformance with the Contract Documents, in the discretion of the Owner, shall be removed and replaced at the Contractor's expense.

B.7.3 Contractor shall make or obtain at the appropriate time all tests, inspections and approvals of portions of the Work required by the Contract Documents or by Applicable Laws or orders of public authorities having jurisdiction. Unless otherwise provided, the Contractor shall make arrangements for such tests, inspections and approvals with an independent testing laboratory or entity acceptable to the Owner, or with the appropriate public authority, and shall bear all related costs of tests, inspections and approvals. Tests or inspections conducted pursuant to the Contract Documents shall be made promptly to avoid unreasonable delay in the Work. The Contractor shall give the Owner timely notice of when and where tests and inspections are to be made so that the Owner may be present for such procedures. Required certificates of testing, inspection or approval shall, unless otherwise required by the Contract Documents, be secured by the Contractor and promptly delivered to the Owner.

B.7.4 As required by the Contract Documents, Work done or material used without required inspection or testing and/or without providing timely notice to the Owner may be ordered removed at the Contractor's expense.

B.7.5 If directed to do so any time before the Work is accepted, the Contractor shall uncover portions of the completed Work for inspection. After inspection, the Contractor shall restore such portions of Work to the standard required by the Contract. If the Work uncovered is unacceptable or was done without required testing or inspection or sufficient notice to the Owner, the uncovering and restoration shall be done at the Contractor's expense. If the Work uncovered is acceptable and was done with sufficient notice to the Owner, the uncovering and restoration will be paid for pursuant to a Change Order.

B.7.6 If any testing or inspection reveals failure of the portions of the Work to comply with requirements established by the Contract Documents, all costs made necessary by such failure, including those of repeated procedures and compensation for the Owner's and Architect/Engineer's services and expenses, shall be at the Contractor's expense.

B.7.7 When the United States government participates in the cost of the Work, or the Owner has an agreement with other public or private organizations, or if any portion of the Work is being performed for a third party or in close proximity to third party facilities, representatives of these organizations shall have the right to inspect the Work affecting their interests or property. Their right to inspect shall not make them a party to the Contract and shall not interfere with the rights of the parties of the Contract. Instructions or orders of such parties shall be transmitted to the Contractor, through the Owner.

B.8 SEVERABILITY

If any provision of this Contract is declared by a court to be illegal or in conflict with any law, the validity of the remaining terms and provisions shall not be affected and the rights and obligations of the parties shall be construed and enforced as if the Contract did not contain the particular provision held to be invalid.

B.9 ACCESS TO RECORDS

B.9.1 Contractor shall keep, at all times on the Work site, one record copy of the complete Contract Documents, including the Plans, Specifications, Construction Change Directives and addenda, in good order and marked currently to record field changes and selections made during construction, and one record copy of Shop Drawings, Product Data, Samples and similar submittals, and shall at all times give the Owner access thereto.

B.9.2 Contractor shall retain and the Owner and its duly authorized representatives shall have access, for a period not less than ten (10) years, to all Record Documents, financial and accounting

records, and other books, documents, papers and records of Contractor which are pertinent to the Contract, including records pertaining to Overhead and indirect costs, for the purpose of making audit, examination, excerpts and transcripts. If for any reason, any part of the Work or this Contract shall be subject to litigation, Contractor shall retain all such records until all litigation is resolved and Contractor shall continue to provide Owner and/or its agents with full access to such records until such time as all litigation is complete and all periods for appeal have expired and full and final satisfaction of any judgment, order or decree is recorded and Owner receives a record copy of documentation from Contractor.

B.10 WAIVER

Failure of the Owner to enforce any provision of this Contract shall not constitute a waiver or relinquishment by the Owner of the right to such performance in the future nor of the right to enforce any other provision of this Contract.

B.11 SUBCONTRACTS AND ASSIGNMENT

B.11.1 Contractor shall require each Subcontractor, to the extent of the Work to be performed by the Subcontractor, to be bound by the terms and conditions of these OUS Public Improvement General Conditions, and to assume toward the Contractor all of the obligations and responsibilities which the Contractor assumes toward the Owner thereunder, unless (1) the same are clearly inapplicable to the subcontract at issue because of legal requirements or industry practices, or (2) specific exceptions are requested by Contractor and approved in writing by Owner. Where appropriate, Contractor shall require each Subcontractor to enter into similar agreements with sub-subcontractors at any level.

B.11.2 At Owner's request, Contractor shall submit to Owner prior to their execution either Contractor's form of subcontract, or the subcontract to be executed with any particular Subcontractor. If Owner disapproves such form, Contractor shall not execute the form until the matters disapproved are resolved to Owner's satisfaction. Owner's review, comment upon or approval of any such form shall not relieve Contractor of its obligations under this Agreement or be deemed a waiver of such obligations of Contractor.

B.11.3 Contractor shall not assign, sell, or transfer its rights, or delegate its responsibilities under this Contract, in whole or in part, without the prior written approval of the Owner. No such written approval shall relieve Contractor of any obligations of this Contract, and any transferee shall be considered the agent of the Contractor and bound to perform in accordance with the Contract Documents. Contractor shall remain liable as between the original parties to the Contract as if no assignment had occurred.

B.12 SUCCESSORS IN INTEREST

The provisions of this Contract shall be binding upon and shall accrue to the benefit of the parties to the Contract and their respective permitted successors and assigns.

B.13 OWNER'S RIGHT TO DO WORK

Owner reserves the right to perform other or additional work at or near the project site with other forces than those of the Contractor. If such work takes place within or next to the project site, Contractor shall coordinate work with the other contractors or forces, cooperate with all other contractors or forces, carry out the Work in a way that will minimize interference and delay for all forces involved, place and dispose of materials being used so as not to interfere with the operations of another, and join the Work with the work of the others in an acceptable manner and perform it in proper sequence to that of the others. The Owner will resolve any disagreements that may arise

between or among Contractor and the other contractors over the method or order of doing all work (including the Work). In case of unavoidable interference, the Owner will establish work priority (including the Work) which generally will be in the sequence that the contracts were awarded.

B.14 OTHER CONTRACTS

In all cases and at any time, the Owner has the right to execute other contracts related to or unrelated to the Work of this Contract. The Contractor of this Contract shall fully cooperate with any and all other contractors without additional cost to the Owner in the manner described in section B.13.

B.15 GOVERNING LAW

This Contract shall be governed by and construed in accordance with the laws of the State of Oregon without regard to principles of conflict of laws.

B.16 LITIGATION

Any Claim between Owner and Contractor that arises from or relates to this Contract and that is not resolved through the Claims Review Process in Section D.3 shall be brought and conducted solely and exclusively within the Circuit Court of Marion County for the State of Oregon, unless stated otherwise in the Contract Documents, provided, however, if a Claim must be brought in a federal forum, then it shall be brought and conducted solely and exclusively within the United States District Court for the District of Oregon. In no event shall this section be construed as a waiver by the State of Oregon of any form of defense or immunity, whether sovereign immunity, governmental immunity, immunity based on the Eleventh Amendment to the Constitution of the United States or otherwise, from any claim or from the jurisdiction of any court. CONTRACTOR, BY EXECUTION OF THIS CONTRACT, HEREBY CONSENTS TO THE IN PERSONAM JURISDICTION OF THE COURTS REFERENCED IN THIS SECTION B.16.

B.17 ALLOWANCES

B.17.1 The Contractor shall include in the Contract Price all allowances stated in the Contract Documents. Items covered by allowances shall be supplied for such amounts and by such persons or entities as the Owner may direct.

B.17.2 Unless otherwise provided in the Contract Documents:

- (a) when finally reconciled, allowances shall cover the cost to the Contractor of materials and equipment delivered at the site and all required taxes, less applicable trade discounts;
- (b) Contractor's costs for unloading and handling at the site, labor, installation costs, Overhead, profit and other expenses contemplated for stated allowance amounts shall be included in the Contract Price but not in the allowances;
- (c) whenever costs are more than or less than allowances, the Contract Price shall be adjusted accordingly by Change Order. The amount of the Change Order shall reflect (i) the difference between actual costs and the allowances under Section B.17.2(a) and (2) changes in Contractor's costs under Section B.17.2(b).
- (d) Unless Owner requests otherwise, Contractor shall provide to Owner a proposed fixed price for any allowance work prior to its performance.

B.18 SUBMITTALS, SHOP DRAWINGS, PRODUCT DATA AND SAMPLES

B.18.1 The Contractor shall prepare and keep current, for the Architect's/Engineer's approval (or for the approval of Owner if approval authority has not been delegated to the

Architect/Engineer), a schedule and list of submittals which is coordinated with the Contractor's construction schedule and allows the Architect/Engineer reasonable time to review submittals. Owner reserves the right to finally approve the schedule and list of submittals. Submittals include, without limitation, Shop Drawings, Product Data, and Samples which are described below:

- (a) Shop Drawings are drawings, diagrams, schedules and other data specially prepared for the Work by the Contractor or a Subcontractor (including any sub-subcontractor), manufacturer, supplier or distributor to illustrate some portion of the Work.
- (b) Product Data are illustrations, standard schedules, performance charts, instructions, brochures, diagrams and other information furnished by the Contractor to illustrate materials or equipment for some portion of the Work.
- (c) Samples are physical examples which illustrate materials, equipment or workmanship and establish standards by which the Work will be judged.

B.18.2 Shop Drawings, Product Data, Samples and similar submittals are not Contract Documents. The purpose of their submittal is to demonstrate for those portions of the Work for which submittals are required by the Contract Documents the way by which the Contractor proposes to conform to the information given and the design concept expressed in the Contract Documents. Review of submittals by the Architect/Engineer is not conducted for the purpose of determining the accuracy and completeness of other details such as dimensions and quantities, or for substantiating instructions for installation or performance of equipment or systems, or for approval of safety precautions or, unless otherwise specifically stated by the Architect/Engineer, of any construction means, methods, techniques, sequences or procedures, all of which remain the responsibility of the Contractor as required by the Contract Documents. The Architect/Engineer's review of the Contractor's submittals shall not relieve the Contractor of its obligations under the Contract Documents. The Architect/Engineer's approval of a specific item shall not indicate approval of an assembly of which the item is a component. Informational submittals upon which the Architect/Engineer is not expected to take responsive action may be so identified in the Contract Documents. Submittals which are not required by the Contract Documents may be returned by the Architect/Engineer without action.

B.18.3 The Contractor shall review for compliance with the Contract Documents, approve and submit to the Architect/Engineer Shop Drawings, Product Data, Samples and similar submittals required by the Contract Documents with reasonable promptness and in such sequence as to cause no delay in the Work or in the activities of the Owner or of separate contractors. Submittals which are not marked as reviewed for compliance with the Contract Documents and approved by the Contractor may be returned by the Architect/Engineer without action.

B.18.4 By approving and submitting Shop Drawings, Product Data, Samples and similar submittals, the Contractor represents that the Contractor has determined and verified materials, field measurements and field construction criteria related thereto, or will do so, and has checked and coordinated the information contained within such submittals with the requirements of the Work and of the Contract Documents.

B.18.5 The Contractor shall perform no portion of the Work for which the Contract Documents require submittal and review of Shop Drawings, Product Data, Samples or similar submittals until the respective submittal has been approved by the Architect/Engineer.

B.18.6 The Work shall be in accordance with approved submittals except that the Contractor shall not be relieved of responsibility for deviations from requirements of the Contract Documents by the Architect/Engineer's review or approval of Shop Drawings, Product Data, Samples or similar submittals unless the Contractor has specifically informed the Architect/Engineer in writing of such deviation at the time of submittal and (i) the Architect/Engineer has given written approval to the specific deviation as a minor change in the Work, or (ii) a Change Order or Construction Change Directive has been executed by Owner authorizing the deviation. The Contractor shall not be relieved of responsibility for errors or omissions in Shop Drawings, Product Data, Samples or similar submittals by the Architect/Engineer's review or approval thereof.

B.18.7 In the event that Owner elects not to have the obligations and duties described under this Section B.18 performed by the Architect/Engineer, or in the event no Architect/Engineer is employed by Owner on the project, all obligations and duties assigned to the Architect/Engineer hereunder shall be performed by the Owner.

B.19 SUBSTITUTIONS

The Contractor may make Substitutions only with the consent of the Owner, after evaluation by the Owner and only in accordance with a Change Order or Construction Change Directive. Substitutions shall be subject to the requirements of the Bid documents. By making requests for Substitutions, the Contractor: represents that the Contractor has personally investigated the proposed substitute product; represents that the Contractor will provide the same warranty for the Substitution that the Contractor would for the product originally specified unless approved otherwise; certifies that the cost data presented is complete and includes all related costs under this Contract including redesign costs, and waives all claims for additional costs related to the Substitution which subsequently become apparent; and will coordinate the installation of the accepted Substitution, making such changes as may be required for the Work to be completed in all respects.

B.20 USE OF PLANS AND SPECIFICATIONS

Plans, Specifications and related Contract Documents furnished to Contractor by Owner or Owner's Architect/Engineer shall be used solely for the performance of the Work under this Contract. Contractor and its Subcontractors and suppliers are authorized to use and reproduce applicable portions of such documents appropriate to the execution of the Work, but shall not claim any ownership or other interest in them beyond the scope of this Contract, and no such interest shall attach. Unless otherwise indicated, all common law, statutory and other reserved rights, in addition to copyrights, are retained by Owner.

B.21 FUNDS AVAILABLE AND AUTHORIZED

Owner reasonably believes at the time of entering into this Contract that sufficient funds are available and authorized for expenditure to finance the cost of this Contract within the Owner's appropriation or limitation. Contractor understands and agrees that, to the extent that sufficient funds are not available and authorized for expenditure to finance the cost of this Contract, Owner's payment of amounts under this Contract attributable to Services performed after the last day of the current biennium is contingent on Owner receiving from the Oregon Legislative Assembly appropriations, limitations or other expenditure authority sufficient to allow Owner, in the exercise of its reasonable administrative discretion, to continue to make payments under this Contract.

B.22 NO THIRD PARTY BENEFICIARIES

Owner and Contractor are the only parties to this Contract and are the only parties entitled to enforce its terms. Nothing in this Contract gives, is intended to give, or shall be construed to give or

provide any benefit or right, whether directly, indirectly, or otherwise, to third persons unless such third persons are individually identified by name herein and expressly described as intended beneficiaries of the terms of this Contract.

SECTION C WAGES AND LABOR

C.1 MINIMUM WAGE RATES ON PUBLIC WORKS

Contractor shall comply fully with the provisions of ORS 279C.800 through 279C.870. Documents establishing those conditions, as determined by the Commissioner of the Bureau of Labor and Industries (BOLI), are included as attachments to or are incorporated by reference in the Contract Documents. Pursuant to ORS 279C.830(1)(d), Contractor shall pay workers at not less than the specified minimum hourly rate of wage, and shall include that requirement in all subcontracts. If the Work is subject to both the state prevailing wage rate law and the federal Davis-Bacon Act, Contractor shall pay the higher of the applicable state or federal prevailing rate of wage. Contractor shall provide written notice to all workers of the number of hours per day and days per week such workers may be required to work.

C.2 PAYROLL CERTIFICATION AND FEE REQUIREMENTS

C.2.1 In accordance with ORS 279C.845, the Contractor and every Subcontractor shall submit written certified statements to the Owner, on the form prescribed by the Commissioner of the Bureau of Labor and Industries, certifying the hourly rate of wage paid each worker which the Contractor or the Subcontractor has employed on the project and further certifying that no worker employed on the project has been paid less than the prevailing rate of wage or less than the minimum hourly rate of wage specified in the Contract, which certificate and statement shall be verified by the oath of the Contractor or the Subcontractor that the Contractor or Subcontractor has read the certified statement, that the Contractor or Subcontractor knows the contents of the certified statement, and, that to the Contractor's or Subcontractor's best knowledge and belief, the certified statement is true. The certified statements shall set out accurately and completely the payroll records for the prior week, including the name and address of each worker, the worker's correct classification, rate of pay, daily and weekly number of hours worked, deductions made, and actual wages paid. Certified statements for each week during which the Contractor or Subcontractor has employed a worker on the project shall be submitted once a month, by the fifth business day of the following month. The Contractor and Subcontractors shall preserve the certified statements for a period of ten (10) years from the date of completion of the Contract.

C.2.2 Pursuant to ORS 279C.845(7), the Owner shall retain 25 percent of any amount earned by the Contractor on this public works project until the Contractor has filed the certified statements required by section C.2.1. The Owner shall pay to the Contractor the amount retained under this subsection within 14 days after the Contractor files the required certified statements, regardless of whether a Subcontractor has failed to file certified statements.

C.2.3 Pursuant to ORS 279C.845(8), the Contractor shall retain 25 percent of any amount earned by a first-tier Subcontractor on this public works project until the first-tier Subcontractor has filed with the Owner the certified statements required by C.2.1. Before paying any amount retained under this subsection, the Contractor shall verify that the first-tier Subcontractor has filed the certified statement. Within 14 days after the first-tier Subcontractor files the required certified statement the

Contractor shall pay the first-tier Subcontractor any amount retained under this subsection.

- C.2.4 In accordance with statutory requirements and administrative rules promulgated by the Commissioner of the Bureau of Labor and Industries, the fee required by ORS 279C.825(1) will be paid by Owner to the Commissioner.

C.3 PROMPT PAYMENT AND CONTRACT CONDITIONS

C.3.1 As a condition to Owner's performance hereunder, the Contractor shall:

- C.3.1.1 Make payment promptly, as due, to all persons supplying to Contractor labor or materials for the prosecution of the Work provided for in this Contract.
- C.3.1.2 Pay all contributions or amounts due the State Industrial Accident Fund from such Contractor or Subcontractor incurred in the performance of the Contract.
- C.3.1.3 Not permit any lien or claim to be filed or prosecuted against the Owner on account of any labor or material furnished. Contractor will not assign any claims that Contractor has against Owner, or assign any sums due by Owner, to Subcontractors, suppliers, or manufacturers, and will not make any agreement or act in any way to give Subcontractors a claim or standing to make a claim against the Owner.
- C.3.1.4 Pay to the Department of Revenue all sums withheld from employees pursuant to ORS 316.167.
- C.3.2 As a condition to Owner's performance hereunder, if Contractor fails, neglects or refuses to make prompt payment of any claim for labor or services furnished to the Contractor or a Subcontractor by any person in connection with the project as such claim becomes due, the proper officer(s) representing the Owner may pay the claim and charge the amount of the payment against funds due or to become due Contractor under this Contract. Payment of claims in this manner shall not relieve the Contractor or the Contractor's surety from obligation with respect to any unpaid claims.
- C.3.3 Contractor shall include in each subcontract for property or services entered into by the Contractor and a first-tier subcontractor, including a material supplier, for the purpose of performing a construction contract, a payment clause that obligates the Contractor to pay the first-tier Subcontractor for satisfactory performance under its subcontract within ten (10) Days out of such amounts as are paid to the Contractor by the public contracting agency under such contract.
- C.3.4 All employers, including Contractor, that employ subject workers who work under this contract in the State of Oregon shall comply with ORS 656.017 and provide the required Workers' Compensation coverage, unless such employers are exempt under ORS 656.126. Contractor shall ensure that each of its Subcontractors complies with these requirements.

C.4 PAYMENT FOR MEDICAL CARE

As a condition to Owner's performance hereunder, Contractor shall promptly, as due, make payment to any person, partnership, association or corporation furnishing medical, surgical, and hospital care or other needed care and attention, incident to sickness or injury, to the employees of such Contractor, all sums of which the Contractor agrees to pay for such services and all moneys and sums which the Contractor has collected or deducted from the wages of personnel pursuant to any law, contract or agreement for the purpose of providing or paying for such services.

C.5 HOURS OF LABOR

As a condition to Owner's performance hereunder, no person shall be employed to perform Work under this Contract for more than ten (10) hours in any one day or forty (40) hours in any one week, except in cases of necessity, emergency or where public policy absolutely requires it. In such instances, Contractor shall pay the employee at least time and a half pay:

- (a) For all overtime in excess of eight (8) hours a day or forty (40) hours in any one week when the work week is five consecutive Days, Monday through Friday; or
- (b) For all overtime in excess of ten (10) hours a day or forty (40) hours in any one week when the work week is four consecutive Days, Monday through Friday; and
- (c) For all Work performed on Saturday and on any legal holiday specified in ORS 279C.540.

This section C.5 will not apply to Contractor's Work under this Contract to the extent Contractor is currently a party to a collective bargaining agreement with any labor organization.

This Section C.5 shall not excuse Contractor from completion of the Work within the time required under this Contract.

SECTION D CHANGES IN THE WORK

D.1 CHANGES IN WORK

- D.1.1 The terms of this Contract shall not be waived, altered, modified, supplemented or amended in any manner whatsoever, without prior written agreement and then only after any necessary approvals have been obtained. A Change Order is required, which shall not be effective until its execution by the parties to this Contract and all approvals required by public contracting laws have been obtained.
- D.1.2 It is mutually agreed that changes in Plans, quantities, or details of construction are inherent in the nature of construction and may be necessary or desirable during the course of construction. Within the general scope of this Contract, the Owner may at any time, without notice to the sureties and without impairing the Contract, require changes consistent with this Section D.1. All changes to the Work shall be documented and Change Orders shall be executed under the conditions of the Contract Documents. Such changes may include, but are not limited to:
- (a) Modification of specifications and design.
- (b) Increases or decreases in quantities.
- (c) Increases or decreases to the amount of Work.
- (d) Addition or elimination of any Work item.
- (e) Change in the duration of the project.
- (f) Acceleration or delay in performance of Work.
- (g) Deductive changes.

Deductive changes are those that reduce the scope of the Work, and shall be made by mutual agreement whenever feasible. In cases of suspension or partial termination under Section J, Owner reserves the right to unilaterally impose a deductive change and to self perform such Work, for which the provisions of B.13 (Owner's Right to Do Work) shall then apply. Adjustments in compensation shall be made under the provisions of D.1.3, in which costs for deductive changes shall be based upon a Direct Costs adjustment together with the related percentage markup specified for profit, Overhead and other indirect costs, unless otherwise agreed to by Owner.

- D.1.3 The Owner and Contractor agree that adjustments to or deletions from the Work shall be administered and compensated according to the following:

- (a) Unit pricing may be utilized at the Owner’s option when unit prices or solicitation alternates were provided that established the cost for adjustments to Work, and a binding obligation exists under the Contract on the parties covering the terms and conditions of the adjustment to Work.
- (b) If the Owner elects not to utilize unit pricing, or in the event that unit pricing is not available or appropriate, fixed pricing may be used for adjustments to or deletions from the Work. In fixed pricing the basis of payments or total price shall be agreed upon in writing between the parties to the Contract, and shall be established before the Work is done whenever feasible. Notwithstanding the foregoing, the mark-ups set forth in D.1.3(c) shall be utilized in establishing fixed pricing, and such mark-ups shall not be exceeded. Cost and price data relating to adjustments to or deletions from the Work shall be supplied by Contractor to Owner upon request, but Owner shall be under no obligation to make such requests.
- (c) In the event that unit pricing and fixed pricing are not utilized, then adjustments to or deletions from the Work shall be performed on a cost reimbursement basis for Direct Costs. Such Work shall be compensated on the basis of the actual, reasonable and allowable cost of labor, equipment, and material furnished on the Work performed. In addition, the following markups shall be added to the Contractor’s or Subcontractor’s Direct Costs as full compensation for profit, Overhead and other indirect costs for Work directly performed with the Contractor’s or Subcontractor’s own forces:

On Labor.....	15%
On Equipment.....	10%
On Materials.....	10%

- (d) When adjustments to or deletions from the Work under D.1.3(c) are invoiced by an authorized Subcontractor at any level, each ascending tier Subcontractor or Contractor will be allowed a supplemental mark-up on each piece of subcontract Work covered by a Change Order as follows:

\$0.00 - \$5,000.00	10%, and then
Over \$5,000.00	5%

Payments made to the Contractor shall be complete compensation for Overhead, profit, and all costs that were incurred by the Contractor or by other forces furnished by the Contractor, including Subcontractors, for adjustments to or deletions from the Work pursuant to a Change Order. Owner may establish a maximum cost for additional Work under this Section D.1.3, which shall not be exceeded for reimbursement without additional written authorization from Owner in the form of a Change Order. Contractor shall not be required to complete such additional Work without additional authorization.

- D.1.4 Any necessary adjustment of Contract Time that may be required as a result of adjustments to or deletions from the Work must be agreed upon by the parties before the start of the revised Work unless Owner authorizes Contractor to start the revised Work before agreement on Contract Time adjustment. Contractor shall submit any request for additional compensation (and additional Contract Time if Contractor was authorized to start Work before an adjustment of Contract Time was approved) as soon as possible but no later than thirty (30) Days after receipt of Owner’s request for additional Work. If Contractor’s request for additional compensation or adjustment of Contract Time is not made within the thirty (30) Day time limit, Contractor’s requests pertaining to that additional Work shall be barred. The thirty (30) Day time limit for making requests shall not be extended for any reason, including without

limitation Contractor’s claimed inability to determine the amount of additional compensation or adjustment of Contract Time, unless an extension is granted in writing by Owner. If the Owner denies Contractor’s request for additional compensation or adjustment of Contract Time, Contractor may proceed to file a Claim under Section D.3, Claims Review Process. No other reimbursement, compensation, or payment will be made, except as provided in Section D.1.5 for impact claims.

- D.1.5 If any adjustment to Work under Section D.1.3 causes an increase or decrease in the Contractor’s cost of, or the Contract Time required for the performance of any other part of the Work under this Contract, Contractor shall submit a written request to the Owner, setting forth the nature and specific extent of the request, including all time and cost impacts against the Contract as soon as possible, but no later than thirty (30) Days after receipt of Owner’s request for adjustments to or deletions from the Work by Contractor.

The thirty (30) Day time limit applies to claims of Subcontractors, suppliers, or manufacturers who may be affected by Owner’s request for adjustments to or deletions from the Work and who request additional compensation or an extension of Contract Time to perform; Contractor has responsibility for contacting its Subcontractors, suppliers, or manufacturers within the thirty (30) Day time limit, and including their requests with Contractor’s requests. If the request involves Work to be completed by Subcontractors, or materials to be furnished by suppliers or manufacturers, such requests shall be submitted to the Contractor in writing with full analysis and justification for the adjustments to compensation and Contract Time requested. The Contractor shall analyze and evaluate the merits of the requests submitted by Subcontractors, suppliers, and manufacturers to Contractor prior to including those requests and Contractor’s analysis and evaluation of those requests with Contractor’s requests for adjustments to compensation or Contract Time that Contractor submits to the Owner. Failure of Subcontractors, suppliers, manufacturers or others to submit their requests to Contractor for inclusion with Contractor’s requests submitted to Owner within the time period and by the means described in this section shall constitute a waiver of these Subcontractor claims. The Owner will not consider direct requests or claims from Subcontractors, suppliers, manufacturers or others not a party to this Contract. The consideration of such requests and claims under this section does not give any Person, not a party to the Contract the right to bring a claim against Owner, whether in this claims process, in litigation, or in any dispute resolution process.

If the Owner denies the Contractor’s request for adjustment to compensation or Contract Time, the Contractor may proceed to file a Claim under Section D.3, Claims Review Process.

- D.1.6 No request or Claim by the Contractor for additional costs or an adjustment of Contract Time shall be allowed if made after receipt of final payment application under this Contract. Final payment application must be made by Contractor within the time required under Section E.6.4.
- D.1.7 It is understood that changes in the Work are inherent in construction of this type. The number of changes, the scope of those changes, and the effect they have on the progress of the original Work cannot be defined at this time. The Contractor is notified that numerous changes may be required and that there will be no compensation made, unless and only to the extent otherwise provided in the Contract Documents, to the Contractor directly related to the number of changes. Each change will be evaluated for extension of Contract Time and increase or decrease in compensation based on its own merit.

D.2 DELAYS

D.2.1 Delays in construction include "Avoidable Delays", which are defined in Section D.2.1.1, and "Unavoidable Delays", which are defined in Section D.2.1.2. The effect of Avoidable Delays is described in Section D.2.2 and the effect of Unavoidable Delays is described in Section D.2.3.

D.2.1.1 Avoidable Delays include any delays other than Unavoidable Delays, and include delays that otherwise would be considered Unavoidable Delays but that:

- (a) Could have been avoided by the exercise of care, prudence, foresight, and diligence on the part of the Contractor or its Subcontractors.
- (b) Affect only a portion of the Work and do not necessarily prevent or delay the prosecution of neither other parts of the Work nor the completion of the whole Work within the Contract Time.
- (c) Do not impact activities on the accepted critical path schedule.
- (d) Are associated with the reasonable interference of other contractors employed by the Owner that do not necessarily prevent the completion of the whole Work within the Contract Time.

D.2.1.2 Unavoidable Delays include delays other than Avoidable Delays that are:

- (a) To the extent caused by any actions of the Owner, or any other employee or agent of the Owner, or by separate contractor employed by the Owner.
- (b) To the extent caused by any site conditions which differ materially from what was represented in the Contract Documents or from conditions that would normally be expected to exist and be inherent to the construction activities defined in the Contract Documents. The Contractor shall notify the Owner immediately of differing site conditions before the area has been disturbed. The Owner will investigate the area and make a determination as to whether or not the conditions differ materially from either the conditions stated in the Contract Documents or those which could reasonably be expected in execution of this particular Contract. If Contractor and the Owner agree that a differing site condition exists, any adjustment to compensation or Contract Time will be determined based on the process set forth in Section D.1.5 for adjustments to or deletions from Work. If the Owner disagrees that a differing site condition exists and denies Contractor's request for additional compensation or Contract Time, Contractor may proceed to file a Claim under Section D.3, Claims Review Process.
- (c) To the extent caused by Force Majeure acts, events or occurrences that could not have been avoided by the exercise of care, prudence, foresight, and diligence on the part of the Contractor or its Subcontractors.
- (d) To the extent caused by adverse weather conditions. Any adverse weather conditions must be substantiated by documentary evidence that weather conditions were abnormal for the specific time period claimed, could not have been anticipated by the Contractor, and adversely impacted the project in a manner that could not be avoided by rescheduling the Work or by implementing measures to protect against the weather so that the Work could proceed. A rain, windstorm, high water, or other natural phenomenon for the specific locality of the Work, which might reasonably have been anticipated from the previous 10-year historical records of the general locality of the Work, shall not be construed as abnormal. The parties

agree that rainfall greater than the following levels cannot be reasonably anticipated:

- (i) Daily rainfall equal to, or greater than, 0.50 inch during a month when the monthly rainfall exceeds the normal monthly average by twenty-five percent (25 %) or more.
- (ii) daily rainfall equal to, or greater than, 0.75 inch at any time.

The Office of the Environmental Data Service of the National Oceanic and Atmospheric Administration of the U.S. Department of Commerce nearest the project site shall be considered the official agency of record for weather information.

D.2.2 Contractor shall not be entitled to additional compensation or additional Contract Time for Avoidable Delays.

D.2.3 In the event of Unavoidable Delays, based on principles of equitable adjustment, Contractor may be entitled to the following:

- (a) Contractor may be entitled to additional compensation or additional Contract Time, or both, for Unavoidable Delays described in Section D.2.1.2 (a) and (b).
- (b) Contractor may be entitled to additional Contract Time for Unavoidable Delays described in Section D.2.1.2(c) and (d).

In the event of any requests for additional compensation or additional Contract Time, or both, as applicable, arising under this Section D.2.3 for Unavoidable Delays, other than requests for additional compensation or additional Contract Time for differing site conditions for which a review process is established under Section D.2.1.2 (b), Contractor shall submit a written notification of the delay to the Owner within two (2) Days of the occurrence of the cause of the delay. This written notification shall state the cause of the potential delay, the project components impacted by the delay, and the anticipated additional Contract Time extension or the additional compensation, or both, as applicable, resulting from the delay. Within seven (7) Days after the cause of the delay has been mitigated, or in no case more than thirty (30) Days after the initial written notification, the Contractor shall submit to the Owner, a complete and detailed request for additional compensation or additional Contract Time, or both, as applicable, resulting from the delay. If the Owner denies Contractor's request for additional compensation or adjustment of Contract Time, the Contractor may proceed to file a Claim under Section D.3, Claims Review Process.

If Contractor does not timely submit the notices required under this Section D.2, then unless otherwise prohibited by law, Contractor's Claim shall be barred.

D.3 CLAIMS REVIEW PROCESS

D.3.1 All Contractor Claims shall be referred to the Owner for review. Contractor's Claims, including Claims for adjustments to compensation or Contract Time, shall be submitted in writing by Contractor to the Owner within five (5) Days after a denial of Contractor's initial request for an adjustment of Contract terms, payment of money, extension of Contract Time or other relief, provided that such initial request has been submitted in accordance with the requirements and within the time limits established in these OUS Public Improvement General Conditions. Within thirty (30) Days after the initial Claim, Contractor shall submit to the Owner a complete and detailed description of the Claim (the "Detailed Notice") that includes all information required by Section D.3.2. Unless the Claim is

made in accordance with these time requirements, it shall be waived by Contractor.

- D.3.2 The Detailed Notice of the Claim shall be submitted in writing by Contractor and shall include a detailed, factual statement of the basis of the Claim, pertinent dates, Contract provisions which support or allow the Claim, reference to or copies of any documents which support the Claim, the dollar value of the Claim, and the Contract Time adjustment requested for the Claim. If the Claim involves Work to be completed by Subcontractors, the Contractor will analyze and evaluate the merits of the Subcontractor claim prior to forwarding it and that analysis and evaluation to the Owner. The Owner will not consider direct claims from Subcontractors, suppliers, manufacturers, or others not a party to this Contract. Contractor agrees that it will make no agreement, covenant, or assignment, nor will it commit any other act that will permit or assist any Subcontractor, supplier, manufacturer, or other to directly or indirectly make a claim against Owner.
- D.3.3 The Owner will review all Claims and take one or more of the following preliminary actions within ten (10) Days of receipt of the Detailed Notice of a Claim: (1) request additional supporting information from the Contractor; (2) inform the Contractor and Owner in writing of the time required for adequate review and response; (3) reject the Claim in whole or in part and identify the reasons for rejection; (4) based on principles of equitable adjustment, recommend approval of all or part of the Claim; or (5) propose an alternate resolution.
- D.3.4 The Owner's decision shall be final and binding on the Contractor unless appealed by written notice to the Owner within fifteen (15) Days of receipt of the decision. The Contractor must present written documentation supporting the Claim within fifteen (15) Days of the notice of appeal. After receiving the appeal documentation, the Owner shall review the materials and render a decision within thirty (30) Days after receiving the appeal documents.
- D.3.5 The decision of the Owner shall be final and binding unless the Contractor delivers to the Owner its request for mediation, which shall be a non-binding process, within fifteen (15) Days of the date of the Owner's decision. The mediation process will be considered to have commenced as of the date the Contractor delivers the request. Both parties acknowledge and agree that participation in mediation is a prerequisite to commencement of litigation of any disputes relating to the Contract. Both parties further agree to exercise their best efforts in good faith to resolve all disputes within sixty (60) Days of the commencement of the mediation through the mediation process set forth herein.

In the event that a lawsuit must be filed within this sixty (60) Day period in order to preserve a cause of action, the parties agree that, notwithstanding the filing, they shall proceed diligently with the mediation to its conclusion prior to actively prosecuting the lawsuit, and shall seek from the Court in which the lawsuit is pending such stays or extensions, including the filing of an answer, as may be necessary to facilitate the mediation process. Further, in the event settlements are reached on any issues through mediation, the plaintiff shall promptly cause to be entered by the Court a stipulated general judgment of dismissal with prejudice, or other appropriate order limiting the scope of litigation as provided in the settlement.

- D.3.6 Should the parties arrive at an impasse regarding any Claims or disputed Claims, it is agreed that the parties shall participate in mediation as specified in Section D.3.5. The mediation process will be considered to have been commenced as of the date one party delivers to the other its request in writing to mediate. The mediator shall be an individual mutually acceptable to both parties, but in the absence of agreement each party shall select a temporary mediator and the temporary mediators shall jointly

select the permanent mediator. Each party shall pay its own costs for the time and effort involved in mediation. The cost of the mediator shall be split equally between the two parties. Both parties agree to exercise their best effort in good faith to resolve all disputes in mediation. Participation in mediation is a mandatory requirement of both the Owner and the Contractor. The schedule, time and place for mediation will be mutually acceptable, or, failing mutual agreement, shall be as established by the mediator. The parties agree to comply with Owner's administrative rules governing the confidentiality of mediation, if any, and shall execute all necessary documents to give effect to such confidentiality rules. In any event, the parties shall not subpoena the mediator or otherwise require the mediator to produce records, notes or work product, or to testify in any future proceedings as to information disclosed or representations made in the course of mediation, except to the extent disclosure is required by law.

- D.3.7 Unless otherwise directed by Owner, Contractor shall proceed with the Work while any Claim, or mediation or litigation arising from a Claim, is pending. Regardless of the review period or the final decision of the Owner, the Contractor shall continue to diligently pursue the Work as identified in the Contract Documents. In no case is the Contractor justified or allowed to cease or Delay Work, in whole or in part, without a written stop work order from the Owner.

SECTION E PAYMENTS

E.1 SCHEDULE OF VALUES

The Contractor shall submit, at least ten (10) Days prior to submission of its first application for progress payment, a schedule of values ("Schedule of Values") for the contracted Work. This schedule shall provide a breakdown of values for the contracted Work and will be the basis for progress payments. The breakdown shall demonstrate reasonable, identifiable, and measurable components of the Work. Unless objected to by the Owner, this schedule shall be used as the basis for reviewing Contractor's applications for payment. If objected to by Owner, Contractor shall revise the schedule of values and resubmit the same for approval of Owner.

E.2 APPLICATIONS FOR PAYMENT

E.2.1 Owner shall make progress payments on the Contract monthly as Work progresses, in accordance with the requirements of this Section E.2. Applications for payment shall be based upon estimates of Work completed and the Schedule of Values. As a condition precedent to Owner's obligation to pay, all applications for payment shall be approved by the Owner. A progress payment shall not be considered acceptance or approval of any Work or waiver of any defects therein. Owner shall pay to Contractor interest for overdue invoices at the rate of two-thirds of one percent per month on the progress payment, not including retainage, due the Contractor. Overdue invoices will be those that have not been paid within forty five (45) days from the latest of:

- (a) The date of the receipt of the accurate invoice;
- (b) The date Owner receives the correct application for payment if no invoice is received;
- (c) The date all goods and services have been received; or
- (d) The date a Claim is made certain by agreement of the parties or by operation of law.

Notwithstanding the foregoing, in instances when an application for payment is filled out incorrectly, or when there is any defect or impropriety in any submitted application or when there is a good faith dispute, Owner shall so notify the Contractor within

fifteen (15) Days stating the reason or reasons the application for payment is defective or improper or the reasons for the dispute. A defective or improper application for payment, if corrected by the Contractor within seven (7) Days of being notified by the Owner, shall not cause a payment to be made later than specified in this section unless interest is also paid. Payment of interest will be postponed when payment on the principal is delayed because of disagreement between the Owner and the Contractor.

Owner reserves the right, instead of requiring the Contractor to correct or resubmit a defective or improper application for payment, to reject the defective or improper portion of the application for payment and pay the remainder of the application for such amounts which are correct and proper.

Owner, upon written notice to the Contractor, may elect to make payments to the Contractor only by means of Electronic Funds Transfers (EFT) through Automated Clearing House (ACH) payments. If Owner makes this election, the Contractor shall arrange for receipt of the EFT/ACH payments.

E.2.2 Contractor shall submit to the Owner an application for each payment and, if required, receipts or other vouchers showing payments for materials and labor including payments to Subcontractors. Contractor shall include in its application for payment a schedule of the percentages of the various parts of the Work completed, based on the Schedule of Values which shall aggregate to the payment application total, and shall include, on the face of each copy thereof, a certificate in substantially the following form:

"I, the undersigned, hereby certify that the above bill is true and correct, and the payment therefore, has not been received.

Signed: _____
Dated: _____"

E.2.3 Generally, applications for payment will be accepted only for materials that have been installed. Under special conditions, applications for payment for stored materials will be accepted at Owner's sole discretion. Such a payment, if made, will be subject to the following conditions:

(a) The request for stored material shall be submitted at least thirty (30) Days in advance of the application for payment on which it appears. Applications for payment shall be entertained for major equipment, components or expenditures only.

(b) The Contractor shall submit applications for payment showing the quantity and cost of the material stored.

(c) The material shall be stored in a bonded warehouse and Owner shall be granted the right to access the material for the purpose of removal or inspection at any time during the Contract Period.

(d) The Contractor shall name the Owner as co-insured on the insurance policy covering the full value of the property while in the care and custody of the Contractor until it is installed. A certificate noting this coverage shall be issued to the Owner.

(e) Payments shall be made for materials and equipment only. The submitted amount in the application for payment shall be reduced by the cost of transportation from the storage site to the project site and for the cost of an inspector to verify delivery and condition of the goods at the storage site. The cost of storage and inspection shall be borne solely by the Contractor.

(f) Within sixty (60) Days of the application for payment, the Contractor shall submit evidence of payment covering the material and/or equipment stored and of payment for the storage site.

(g) Payment for stored materials and/or equipment shall in no way indicate acceptance of the materials and/or equipment or waive any rights under this Contract for the rejection of the Work or materials and/or equipment not in conformance with the Contract Documents.

(h) All required documentation shall be submitted with the respective application for payment.

E.2.4 The Owner reserves the right to withhold all or part of a payment, or may nullify in whole or part any payment previously made, to such extent as may be necessary in the Owner's opinion to protect the Owner from loss because of:

- (a) Work that is defective and not remedied, or that has been demonstrated or identified as failing to conform with Applicable Laws or the Contract Documents,
- (b) third party claims filed or evidence reasonably indicating that such claims will likely be filed unless security acceptable to the Owner is provided by the Contractor;
- (c) failure of the Contractor to make payments properly to Subcontractors or for labor, materials or equipment (in which case Owner may issue checks made payable jointly to Contractor and such unpaid Persons under this provision, or directly to Subcontractors and suppliers at any level under Section C.3.2.1);
- (d) reasonable evidence that the Work cannot be completed for the unpaid balance of the Contract Price;
- (e) damage to the Work, Owner or another contractor;
- (f) reasonable evidence that the Work will not be completed within the Contract Time required by the Contract, and that the unpaid balance would not be adequate to cover actual or liquidated damages for the anticipated delay;
- (g) failure to carry out the Work in accordance with the Contract Documents; or
- (h) assessment of liquidated damages, when withholding is made for offset purposes.

E.2.5 Subject to the provisions of the Contract Documents, the amount of each progress payment shall be computed as follows:

- (a) Take that portion of the Contract Price properly allocable to completed Work as determined by multiplying the percentage completion of each portion of the Work by the share of the total Contract Price allocated to that portion of the Work in the Schedule of Values, less retainage as provided in Section E.5. Pending final determination of cost to the Owner of changes in the Work, no amounts for changes in the Work can be included in applications for payment until the Contract Price has been adjusted by a Change Order;
- (b) Add that portion of the Contract Price properly allocable to materials and equipment delivered and suitably stored at the site for subsequent incorporation in the completed construction (or, if approved in advance by the Owner pursuant to Section E.2.3, suitably stored off the site at a location agreed upon in writing), less retainage as provided in Section E.5;
- (c) Subtract the aggregate of previous payments made by the Owner; and
- (d) Subtract any amounts for which the Owner has withheld or nullified payment as provided in the Contract Documents.

E.2.6 Contractor's applications for payment shall not include requests for payment for portions of the Work for which the Contractor does not intend to pay to a Subcontractor or material supplier.

E.2.7 The Contractor warrants to Owner that title to all Work covered by an application for payment will pass to the Owner no later than the time of payment. The Contractor further warrants that upon submittal of an application for payment all Work for which payments are received from the Owner shall be free and clear of liens, claims, security interests or encumbrances in favor of the Contractor, Subcontractors, material suppliers, or other persons or entities making a claim by reason of having provided financing, labor, materials and equipment relating to the Work.

E.2.8 If Contractor disputes any determination by Owner with regard to any application for payment, Contractor nevertheless shall continue to expeditiously perform the Work. No payment made hereunder shall be or be construed to be final acceptance or approval of that portion of the Work to which such partial payment relates or shall relieve Contractor of any of its obligations hereunder.

E.2.9 Contractor shall submit its initial MWESB Report within ten (10) Days of Contractor's execution of the Contract. Contractor shall submit annual MWESB Reports on June 30 of each year the Contract is active. Contracts - first executed by Contractor within ninety (90) Days before June 30 of the year of execution by Contractor may at the discretion of Owner be exempt from submitting the annual MWESB Report otherwise due on that June 30. The final MWESB Report shall be filed with the application for final payment. Timely receipt of MWESB Reports by Owner shall be a condition precedent to Owner's obligation to pay any progress payments or final payment otherwise due.

E.3 PAYROLL CERTIFICATION REQUIREMENT

Owner's receipt of payroll certification pursuant to Section C.2 of this Contract shall be a condition precedent to Owner's obligation to pay any progress payments or final payment otherwise due.

E.4 DUAL PAYMENT SOURCES

Contractor shall not be compensated for Work performed under this Contract from any state agency other than the agency that is a party to this Contract.

E.5 RETAINAGE

E.5.1 Retainage shall be withheld and released in accordance with the requirements set forth in OAR 580-063-0045.

E.5.1.1 Owner may reserve as retainage from any progress payment an amount not to exceed five percent of the payment. As Work progresses, Owner may reduce the amount of retainage on or may eliminate retainage on any remaining monthly Contract payments after 50 percent of the Work under the Contract is completed if, in the Owner's discretion, such Work is progressing satisfactorily. Elimination or reduction of retainage shall be allowed only upon written application by the Contractor, which application shall include written approval of Contractor's surety; except that when the Work is 97-1/2 percent completed the Owner may, at its discretion and without application by the Contractor, reduce the retained amount to 100 percent of the value of the Work remaining to be done. Upon receipt of written application by the Contractor, Owner shall respond in writing within a reasonable time.

E.5.1.2 Contractor may request in writing:

(a) to be paid amounts which would otherwise have been retained from progress payments where Contractor has deposited acceptable bonds and securities of equal value with Owner or in a custodial account or other mutually-agreed account satisfactory to Owner, with an approved bank or trust company to be held in lieu of the cash retainage for the benefit of Owner;

(b) for construction projects over \$1,000,000, that retainage be deposited in an interest bearing account, established through the State Treasurer for state agencies, in a bank, savings bank, trust company or savings association for the benefit of Owner, with earnings from such account accruing to the Contractor; or

(c) that the Owner allow Contractor to deposit a surety bond for the benefit of Owner, in a form acceptable to Owner, in lieu of all or a portion of funds retained, or to be retained. Such bond and any proceeds therefrom shall be made subject to all claims in the manner and priority as set forth for retainage.

When the Owner has accepted the Contractor's election of option (a) or (b), Owner may recover from Contractor any additional costs incurred through such election by reducing Contractor's final payment. Where the Owner has agreed to Contractor's request for option (c), Contractor shall accept like bonds from Subcontractors and suppliers on the project from which Contractor has required retainages.

E. 5.1.3 The retainage held by Owner shall be included in and paid to the Contractor as part of the final payment of the Contract Price. The Owner shall pay to Contractor interest at the rate of two-thirds of one percent per month on the final payment due Contractor, interest to commence forty five (45) Days after the date which Owner receives Contractor's final approved application for payment and Work under the Contract has been completed and accepted and to run until the date when final payment is tendered to Contractor. The Contractor shall notify Owner in writing when the Contractor considers the Work complete and deliver to Owner its final application for payment and Owner shall, within thirty (30) Days after receiving the written notice and the application for payment, either accept the Work or notify the Contractor of Work yet to be performed on the Contract. If Owner does not within the time allowed notify the Contractor of Work yet to be performed to fulfill contractual obligations, the interest provided by this subsection shall commence to run forty five (45) Days after the end of the 30-Day period.

E.5.1.4 Owner will reduce the amount of the retainage if the Contractor notifies the Owner that the Contractor has deposited in an escrow account with a bank or trust company, in a manner authorized by the Owner, bonds and securities of equal value of a kind approved by the Owner and such bonds and securities have in fact been deposited in accordance with Applicable Laws.

E.5.1.5 Contractor agrees that if Contractor elects to reserve a retainage from any progress payment due to any Subcontractor or supplier, such retainage shall not exceed five percent of the payment, and such retainage withheld from Subcontractors and suppliers shall be subject to the same terms and conditions stated in Subsection E.5 as apply to Owner's retainage from any progress payment due to Contractor.

E.6 FINAL PAYMENT

E.6.1 Upon completion of all the Work under this Contract, the Contractor shall notify the Owner, in writing, that Contractor has completed Contractor's obligations under the Contract and shall prepare its application requesting final payment. Upon receipt

of such notice and application for payment, the Owner will inspect the Work, and, if acceptable, submit to Contractor a recommendation as to acceptance of the completed Work and the final estimate of the amount due the Contractor. If the Work is not acceptable, Owner will notify Contractor within fifteen (15) Days of Contractor's request for final payment. Upon approval of this final application for payment by the Owner and compliance by the Contractor with provisions in Section K, and Contractor's satisfaction of other provisions of the Contract Documents as may be applicable, the Owner shall pay to the Contractor all monies due under the provisions of these Contract Documents.

- E.6.2 Neither final payment nor any remaining retained percentage shall become due until the Contractor submits to the Owner (1) a certificate evidencing that insurance required by the Contract Documents to remain in force after final payment is currently in effect and will not be canceled or allowed to expire until at least thirty (30) Days' prior written notice has been given to the Owner, (2) a written statement that the Contractor knows of no substantial reason that the insurance will not be renewable to cover the period required by the Contract Documents, (3) consent of surety, if any, to final payment and (4), if required by the Owner, other data establishing payment or satisfaction of obligations, such as receipts, releases and waivers of liens, claims, security interests or encumbrances arising out of the Contract, to the extent and in such form as may be designated by the Owner. If a Subcontractor refuses to furnish a release or waiver required by the Owner, the Contractor may furnish a bond satisfactory to the Owner to indemnify the Owner against such lien. If such lien remains unsatisfied after payments are made, the Contractor shall refund to the Owner all money that the Owner may be compelled to pay in discharging such lien, including all costs and reasonable attorneys' fees.
- E.6.3 Acceptance of final payment by the Contractor, a Subcontractor or material supplier shall constitute a waiver of claims by that payee except those previously made in writing and identified by that payee as unsettled at the time of final application for payment.
- E.6.4 Contractor agrees to submit its final payment application within ninety (90) Days after Substantial Completion, unless written extension is granted by Owner. Contractor shall not delay final payment application for any reason, including without limitation nonpayment of Subcontractors, suppliers, manufacturers or others not a party to this Contract, or lack of resolution of a dispute with Owner or any other person of matters arising out of or relating to the Contract. If Contractor fails to submit its final payment application within ninety (90) Days after Substantial Completion, and Contractor has not obtained written extension by Owner, all requests or Claims for additional costs or an extension of Contract Time shall be waived.

SECTION F JOB SITE CONDITIONS

F.1 USE OF PREMISES

Contractor shall confine equipment, storage of materials and operation of Work to the limits indicated by Contract Documents, Applicable Laws, permits or directions of the Owner. Contractor shall follow the Owner's instructions regarding use of premises, if any.

F.2 PROTECTION OF WORKERS, PROPERTY AND THE PUBLIC

F.2.1 Contractor shall maintain continuous and adequate protection of all of the Work from damage and shall protect the Owner, workers and property from injury or loss arising in connection with this Contract. Contractor shall remedy acceptably to the Owner any damage, injury, or loss, except such as may be directly due to errors in the Contract Documents or caused by authorized representatives or personnel of the Owner.

Contractor shall adequately protect adjacent property as provided by law and the Contract Documents.

- F.2.2 Contractor shall take all necessary precautions for the safety of all personnel on the job site or otherwise engaged in the undertaking of the Work and shall comply with the Contract Documents, best practices and all applicable provisions of federal, state and municipal safety laws and building and fire codes to prevent accidents or injury to persons on, about or adjacent to the premises where the Work is being performed. Contractor shall erect and properly maintain at all times, as required by the conditions and progress of the Work, all necessary safeguards for protection of workers and the public against any hazards created by construction. Contractor shall designate a responsible employee or associate on the Work site, whose duty shall be the prevention of accidents. The name and position of the person designated shall be reported to the Owner. The Owner has no responsibility for Work site safety. Work site safety shall be the responsibility of the Contractor.
- F.2.3 Contractor shall not enter upon private property without first obtaining permission from the property owner or its duly authorized representative. Contractor shall be responsible for the preservation of all public and private property along and adjacent to the Work contemplated under the Contract and shall use every precaution necessary to prevent damage thereto. In the event the Contractor damages any property, the Contractor shall at once notify the property owner and make, or arrange to make, full restitution. Contractor shall, immediately and in writing, report to the Owner, all pertinent facts relating to such property damage and the ultimate disposition of the claim for damage.
- F.2.4 Contractor shall be responsible for protection of adjacent work areas including impacts brought about by activities, equipment, labor, utilities, vehicles and materials on the site.
- F.2.5 Contractor shall at all times direct its activities in such a manner as to minimize adverse effects on the environment. Handling of all materials shall be conducted so no release will occur that may pollute or become hazardous.
- F.2.6 In an emergency affecting the safety of life or limb or of the Work or of adjoining property, the Contractor, without special instruction or authorization from the Owner, shall act reasonably to prevent threatened loss or injury, and shall so act, without appeal, if instructed by the Owner. Any compensation claimed by the Contractor on account of emergency work shall be determined in accordance with section D.

F.3 CUTTING AND PATCHING

- F.3.1 Contractor shall be responsible for coordinating all cutting, fitting, or patching of the Work to make its several parts come together properly and fit to receive or be received by work of other contractors or Subcontractors shown upon, or reasonably implied by, the Contract Documents.
- F.3.2 Contractor shall be responsible for restoring all cut, fitted, or patched surfaces to an original condition; provided, however, that if a different condition is specified in the Contract Documents, then Contractor shall be responsible for restoring such surfaces to the condition specified in the Contract Documents.

F.4 CLEANING UP

From time to time as may be prudent or ordered by the Owner and, in any event, immediately after completion of the Work, the Contractor shall, at its own expense, clean up and remove all refuse and unused materials of any kind resulting from the Work. If Contractor fails to do so within twenty-four hours after notification by the Owner

the work may be done by others and the cost charged to the Contractor and deducted from payment due the Contractor.

F.5 ENVIRONMENTAL CONTAMINATION

F.5.1. Contractor shall be held responsible for and shall indemnify, defend (with counsel of Owner's choice), and hold harmless Owner from and against any costs, expenses, damages, claims, and causes of action, (including attorney fees), or any of them, resulting from all spills, releases, discharges, leaks and disposal of environmental pollution, including storage, transportation, and handling during the performance of the Work or Contractor's obligations under the Contract which occur as a result of, or are contributed by, the negligence or actions of Contractor or its personnel, agents, or Subcontractors or any failure to perform in accordance with the Contract Documents (except to the extent otherwise void under ORS 30.140). Nothing in this section F.5.1 shall limit Contractor's responsibility for obtaining insurance coverages required under Section G.3 of this Contract, and Contractor shall take no action that would void or impair such coverages.

F.5.1.1 Contractor agrees to promptly dispose of such spills, releases, discharge or leaks to the satisfaction of Owner and regulatory agencies having jurisdiction in a manner that complies with Applicable Laws. Cleanup shall be at no cost to the Owner and shall be performed by properly qualified and, if applicable, licensed personnel.

F.5.1.2 Contractor shall obtain the Owner's written consent prior to bringing onto the Work site any (i) environmental pollutants or (ii) hazardous substances or materials, as the same or reasonably similar terms are used in any Applicable Laws. Notwithstanding such written consent from the Owner, the Contractor, at all times, shall:

- (a) properly handle, use and dispose of all environmental pollutants and hazardous substances or materials brought onto the Work site, in accordance with all Applicable Laws;
- (b) be responsible for any and all spills, releases, discharges, or leaks of (or from) environmental pollutants or hazardous substances or materials which Contractor has brought onto the Work site; and
- (c) promptly clean up and remediate, without cost to the Owner, such spills, releases, discharges, or leaks to the Owner's satisfaction and in compliance with all Applicable Laws.

F.5.2 Contractor shall report all reportable quantity releases, as such releases are defined in Applicable Laws, including but not limited to 40 CFR Part 302, Table 302.4 and in OAR 340-142-0050, to applicable federal, state, and local regulatory and emergency response agencies. Upon discovery, regardless of quantity, Contractor must telephonically report all releases to the Owner. A written follow-up report shall be submitted to Owner within 48 hours of the telephonic report. Such written report shall contain, as a minimum:

- (a) Description of items released (identity, quantity, manifest numbers, and any and all other documentation required by law.)
- (b) Whether amount of items released is EPA/DEQ reportable, and, if so, when reported.
- (c) Exact time and location of release, including a description of the area involved.
- (d) Containment procedures initiated.

(e) Summary of communications about the release between Contractor and members of the press or State, local or federal officials other than Owner.

(f) Description of cleanup procedures employed or to be employed at the site, including disposal location of spill residue.

(g) Personal injuries, if any, resulting from, or aggravated by, the release.

F.6 ENVIRONMENTAL CLEAN-UP

F.6.1 Unless disposition of environmental pollution is specifically a part of this Contract, or was caused by the Contractor (reference F.5 Environmental Contamination), Contractor shall immediately notify Owner of any hazardous substance(s) which Contractor discovers or encounters during performance of the Work required by this Contract. "Hazardous substance(s)" means any hazardous, toxic and radioactive materials and those substances defined as "hazardous substances," "hazardous materials," "hazardous wastes," "toxic substances," or other similar designations in any federal, state, or local law, regulation, or ordinance, including without limitation asbestos, polychlorinated biphenyl (PCB), or petroleum, and any substances, materials or wastes regulated by 40 CFR, Part 261 and defined as hazardous in 40 CFR S 261.3. In addition to notifying Owner of any hazardous substance(s) discovered or encountered, Contractor shall immediately cease working in any particular area of the project where a hazardous substance(s) has been discovered or encountered if continued work in such area would present a risk or danger to the health or well being of Contractor's or any Subcontractor's work force, property or the environment.

F.6.2 Upon being notified by Contractor of the presence of hazardous substance(s) on the project site, Owner shall arrange for the proper disposition of such hazardous substance(s).

F.7 FORCE MAJEURE

A party to this Contract shall not be held responsible for delay or default due to Force Majeure acts, events or occurrences unless they could have been avoided by the exercise of reasonable care, prudence, foresight, and diligence by that party. The Owner may terminate this Contract upon written notice after determining that delay or default caused by Force Majeure acts, events or occurrences will reasonably prevent successful performance of the Contract.

SECTION G INDEMNITY, BONDING, AND INSURANCE

G.1 RESPONSIBILITY FOR DAMAGES / INDEMNITY

G.1.1 Contractor shall be responsible for all damage to property, injury to persons, and loss, expense, inconvenience, and delay that may be caused by, or result from, the carrying out of the Work to be done under this Contract, or from any act, omission or neglect of the Contractor, its Subcontractors, employees, guests, visitors, invitees and agents.

G.1.2 To the fullest extent permitted by law, Contractor shall indemnify, defend (with counsel approved by Owner) and hold harmless the Owner, Architect/Engineer, Architect/Engineer's consultants, and their respective officers, directors, agents, employees, partners, members, stockholders and affiliated companies (collectively "Indemnitees") from and against all liabilities, damages, losses, claims, expenses (including reasonable attorney fees), demands and actions of any nature whatsoever which arise out of, result from or are related to, (a) any damage, injury, loss, expense, inconvenience or delay described in this Section G.1., (b) any accident or occurrence which happens or is alleged to have happened in or about the

project site or any place where the Work is being performed, or in the vicinity of either, at any time prior to the time the Work is fully completed in all respects, (c) any failure of the Contractor to observe or perform any duty or obligation under the Contract Documents which is to be observed or performed by the Contractor, or any breach of any agreement, representation or warranty of the Contractor contained in the Contract Documents or in any subcontract, (d) the negligent acts or omissions of the Contractor, a Subcontractor or anyone directly or indirectly employed by them or any one of them or anyone for whose acts they may be liable, regardless of whether or not such claim, damage, loss or expense is caused in part by a party indemnified hereunder (except to the extent otherwise void under ORS 30.140), and (e) any lien filed upon the project or bond claim in connection with the Work. Such obligation shall not be construed to negate, abridge, or reduce other rights or obligations of indemnity which would otherwise exist as to a party or person described in this Section G.1.2.

G.1.3 In claims against any person or entity indemnified under Section G.1.2 by an employee of the Contractor, a Subcontractor, anyone directly or indirectly employed by them or anyone for whose acts they may be liable, the indemnification obligation under Section G.1.2 shall not be limited by a limitation on amount or type of damages, compensation or benefits payable by or for the Contractor or a Subcontractor under workers' compensation acts, disability benefit acts or other employee benefit acts.

G.2 PERFORMANCE AND PAYMENT SECURITY; PUBLIC WORKS BOND

G.2.1 When the Contract Price is \$100,000 or more (or \$50,000 or more in the case of Contracts for highways, bridges and other transportation projects), the Contractor shall furnish and maintain in effect at all times during the Contract Period a performance bond in a sum equal to the Contract Price and a separate payment bond also in a sum equal to the Contract Price. Contractor shall furnish such bonds even if the Contract Price is less than the above thresholds if otherwise required by the Contract Documents.

G.2.2 Bond forms furnished by the Owner and notarized by awarded Contractor's surety company authorized to do business in Oregon are the only acceptable forms of performance and payment security, unless otherwise specified in the Contract Documents.

G.2.3 Before execution of the Contract the Contractor shall file with the Construction Contractors Board, and maintain in full force and effect, the separate public works bond required by Oregon Laws 2005, Chapter 360, and OAR 839-025-0015, unless otherwise exempt under those provisions. The Contractor shall also include in every subcontract a provision requiring the Subcontractor to have a public works bond filed with the Construction Contractors Board before starting Work, unless otherwise exempt, and shall verify that the Subcontractor has filed a public works bond before permitting any Subcontractor to start Work.

G.3 INSURANCE

G.3.1 Primary Coverage: Insurance carried by Contractor under this Contract shall be the primary coverage. The coverages indicated are minimums unless otherwise specified in the Contract Documents.

G.3.2 Workers' Compensation: All employers, including Contractor, that employ subject workers who work under this Contract in the State of Oregon shall comply with ORS 656.017 and provide the required Workers' Compensation coverage, unless such employers are exempt under ORS 656.126. This shall include

Employer's Liability Insurance with coverage limits of not less than the minimum amount required by statute for each accident. Contractors who perform the Work without the assistance or labor of any employee need not obtain such coverage if the Contractor certifies so in writing. Contractor shall ensure that each of its Subcontractors complies with these requirements. The Contractor shall require proof of such Workers' Compensation coverage by receiving and keeping on file a certificate of insurance from each Subcontractor or anyone else directly employed by either the Contractor or its Subcontractors.

G.3.3 Builder's Risk Insurance:

G.3.3.1 Builder's Risk: During the term of this Contract, for new construction the Contractor shall obtain and keep in effect Builder's Risk insurance on an all risk forms, including earthquake and flood, for an amount equal to the full amount of the Contract, plus any changes in values due to modifications, Change Orders and loss of materials added. Such Builder's Risk shall include, in addition to earthquake and flood, theft, vandalism, mischief, collapse, transit, debris removal, and architect's fees ("soft costs") associated with delay of project due to insured peril. Any deductible shall not exceed \$50,000 for each loss, except the earthquake and flood deductible which shall not exceed 2 percent of each loss or \$50,000, whichever is greater. The deductible shall be paid by Contractor if Contractor is negligent. The policy will include as loss payees Owner, the Contractor and its Subcontractors as their interests may appear.

G.3.3.2 Builder's Risk Installation Floater: For Work other than new construction, Contractor shall obtain and keep in effect during the term of this Contract, a Builder's Risk Installation Floater for coverage of the Contractor's labor, materials and equipment to be used for completion of the Work performed under this Contract. The minimum amount of coverage to be carried shall be equal to the full amount of the Contract. The policy will include as loss payees Owner, the Contractor and its Subcontractors as their interests may appear. Owner may waive this requirement at its sole and absolute discretion.

G.3.3.3 Such insurance shall be maintained until Owner has occupied the facility.

G.3.3.4 A loss insured under the Builder's Risk insurance shall be adjusted by the Owner and made payable to the Owner as loss payee. The Contractor shall pay Subcontractors their just shares of insurance proceeds received by the Contractor, and by appropriate agreements, written where legally required for validity, shall require Subcontractors to make payments to their Sub-subcontractors in similar manner. The Owner shall have power to adjust and settle a loss with insurers.

G.3.4 General Liability Insurance:

G.3.4.1 Commercial General Liability: Upon execution of this Contract, Contractor shall obtain, and keep in effect at Contractor's expense for the term of this Contract, Commercial General Liability Insurance covering bodily injury and property damage in the amount of \$1,000,000 per claim and \$2,000,000 per occurrence in a form satisfactory to Owner. This insurance shall include personal injury liability, products and completed operations, and contractual liability coverage for the indemnities provided under this Contract (to the extent contractual liability coverage for the indemnity is available in the marketplace), and shall be issued on an occurrence basis.

G.3.4.2 Automobile Liability: Contractor shall obtain, at Contractor's expense, and keep in effect during the term of this Contract, Automobile Liability Insurance covering owned, and/or hired vehicles, as applicable. The coverage may be written in combination with the Commercial General Liability Insurance. Contractor shall provide proof of insurance of not less than

\$1,000,000 per claim and \$2,000,000 per occurrence. Contractor and its Subcontractors shall be responsible for ensuring that all non-owned vehicles maintain adequate Automobile Liability insurance while on site.

- G.3.4.3 Owner may adjust the insurance amounts required in Section G.3.4.1 and G.3.4.2 based upon institution specific risk assessments through the issuance of Supplemental General Conditions to this Contract.
- G.3.4.4 "Tail" Coverage: If any of the required liability insurance is arranged on a "claims made" basis, "tail" coverage will be required at the completion of this Contract for a duration of 36 months or the maximum time period available in the marketplace if less than 36 months. Contractor shall furnish certification of "tail" coverage as described or continuous "claims made" liability coverage for 36 months following Final Completion. Continuous "claims made" coverage will be acceptable in lieu of "tail" coverage, provided its retroactive date is on or before the effective date of this Contract. Owner's receipt of the policy endorsement evidencing such coverage shall be a condition precedent to Owner's obligation to make final payment and to Owner's final acceptance of Work or services and related warranty (if any).
- G.3.4.5: Umbrella Liability (if required by Owner through issuance of Supplemental General Conditions): Contractor shall obtain, at Contractor's expense, and keep in effect during the term of this Contract, Umbrella liability Insurance over and above the general liability, automobile liability and workers' compensation coverage if required by Owner in specified limits at time of requirement.
- G.3.4.6 Pollution Liability (if required by Owner through issuance of Supplemental General Conditions): Contractor shall obtain, at Contractor's expense, and keep in effect during the term of this Contract, Pollution liability Insurance in minimum amounts of \$1,000,000, or other amount as indicated in the Supplemental General Conditions, naming Owner as "additional insured," as noted in the "additional insured section below.
- G.3.5 Additional Insured: The general liability insurance coverage, professional liability, umbrella, and pollution liability if required, shall include the Owner as additional insureds but only with respect to the Contractor's activities to be performed under this Contract.
- If Contractor cannot obtain an insurer to name the Owner as additional insureds, Contractor shall obtain at Contractor's expense, and keep in effect during the term of this Contract, Owners and Contractors Protective Liability Insurance, naming the Owner as additional insureds with not less than a \$2,000,000 limit per occurrence. This policy must be kept in effect for 36 months following Final Completion. As evidence of coverage, Contractor shall furnish the actual policy to Owner prior to execution of the Contract.
- G.3.6 Notice of Cancellation or Change: If the Contractor receives a non-renewal or cancellation notice from an insurance carrier affording coverage required herein, or receives notice that coverage no longer complies with the insurance requirements herein, Contractor agrees to notify Owner by fax within five (5) business days with a copy of the non-renewal or cancellation notice, or written specifics as to which coverage is no longer in compliance. When notified by Owner, the Contractor agrees to stop Work pursuant to this Contract, unless all required insurance remains in effect. Any failure to comply with the reporting provisions of this insurance, except for the potential exhaustion of aggregate limits, shall not affect the coverages provided to the Owner and its institutions, divisions, officers, and employees.

Owner shall have the right, but not the obligation, of prohibiting Contractor from entering the Work site until a new certificate(s) of insurance is provided to Owner evidencing the replacement coverage. The Contractor acknowledges and agrees that Owner reserves the right to withhold payment to Contractor until evidence of reinstated or replacement coverage is provided to Owner.

- G.3.7 Certificate(s) of Insurance: As evidence of the insurance coverage required by this Contract, the Contractor shall furnish certificate(s) of insurance to the Owner prior to execution of the Contract. The certificate(s) will specify all of the parties who are additional insureds or loss payees for this contract. Insurance coverage required under this Contract shall be obtained from insurance companies or entities acceptable to the Owner and that are eligible to provide such insurance under Oregon law. Eligible insurers include admitted insurers that have been issued a certificate of authority from the Oregon Department of Consumer and Business Services authorizing them to conduct an insurance business and issue policies of insurance in the state of Oregon, and certain non-admitted surplus lines insurers that satisfy the requirements of applicable Oregon law and which are subject to approval by the Owner. The Contractor shall be financially responsible for all deductibles, self-insured retentions and/or self-insurance included hereunder. Any deductible, self-insured retention and/or self-insurance in excess of \$50,000 shall be subject to approval by the Owner in writing and shall be a condition precedent to the effectiveness of this Contract.

SECTION H SCHEDULE OF WORK

H.1 CONTRACT PERIOD

- H.1.1 Time is of the essence. The Contractor shall at all times carry on the Work diligently, without delay and punctually fulfill all requirements herein. If required by the Contract Documents, Contractor shall commence Work on the site within fifteen (15) Days of Notice to Proceed, unless directed otherwise.
- H.1.2 Unless specifically extended by Change Order, all Work shall be complete by the date contained in the Contract Documents. The Owner shall have the right to accelerate the completion date of the Work, which may require the use of overtime. Such accelerated Work schedule shall be an acceleration in performance of Work under Section D.1.2 (f) and shall be subject to the provisions of Section D.1.
- H.1.3 The Owner shall not waive any rights under the Contract by permitting the Contractor to continue or complete in whole or in part the Work after the date described in Section H.1.2 above.

H.2 SCHEDULE

H.2.1 Contractor shall provide, by or before the pre-construction conference, the initial as-planned schedule for review and acceptance by the Owner. The submitted schedule must illustrate Work by project components, with labor trades, and long lead items broken down by building and/or floor where applicable. If Owner shall so elect, Contractor shall provide the schedule in CPM format showing the graphical network of planned activities, including i) a reasonably detailed list of all activities required to complete the Work; ii) the time and duration that each activity will take to completion; and iii) the dependencies between the activities. Schedules lacking adequate detail, or unreasonably detailed, will be rejected. The schedule shall include the following: Notice to Proceed or the date the Work commences, if no Notice to Proceed is issued by Owner, Substantial Completion, and Final Completion. Schedules shall be updated monthly, unless otherwise required by the Contract Documents, and submitted with the monthly application for payment. Acceptance of the Schedule by the

Owner does not constitute agreement by the Owner as to the Contractor's sequencing, means, methods, or durations. Any positive difference between the Contractor's scheduled completion and the Contract completion date is float owned by the Owner. Owner reserves the right to negotiate the float if it is deemed to be in Owner's best interest to do so. In no case shall the Contractor make a claim for delays if the Work is completed within the Contract Time but after Contractor's scheduled completion. **H.3 PARTIAL OCCUPANCY OR USE**

H.3.1 The Owner may occupy or use any completed or partially completed portion of the Work at any stage, provided such occupancy or use is consented to by public authorities having jurisdiction over the Work. Such partial occupancy or use may commence whether or not the portion is substantially complete, provided the Owner and Contractor have reasonably accepted in writing the responsibilities assigned to each of them for payments, retainage, if any, security, insurance or self-insurance, maintenance, heat, utilities, and damage to the Work, and have agreed in writing concerning the period for correction of the Work and commencement of warranties required by the Contract Documents with respect to such portion of the Work. Approval by the Contractor to partial occupancy or use shall not be unreasonably withheld. Immediately prior to such partial occupancy or use, the Owner and Contractor shall jointly inspect the area to be occupied or portion of the Work to be used in order to determine and record the condition of the Work. Partial occupancy or use of a portion or portions of the Work shall not constitute acceptance of Work not complying with the requirements of the Contract Documents.

SECTION I CORRECTION OF WORK

I.1 CORRECTION OF WORK BEFORE FINAL PAYMENT

The Contractor warrants to the Owner that materials and equipment furnished under the Contract will be of good quality and new unless otherwise required or permitted by the Contract Documents, that the Work will be free from defects, and that the Work will conform to the requirements of the Contract Documents. Work failing to conform to these requirements shall be deemed defective. Contractor shall promptly remove from the premises and replace all defective materials and equipment as determined by the Owner, whether incorporated in the Work or not. Removal and replacement shall be without loss or expense to the Owner, and Contractor shall bear the cost of repairing all Work destroyed or damaged by such removal or replacement. Contractor shall be allowed a period of no longer than thirty (30) Days after Substantial Completion for completion of defective (Punch List) work. At the end of the thirty-day period, or earlier if requested by the Contractor, Owner shall arrange for inspection of the Work by the Architect/Engineer. Should the work not be complete, and all corrections made, the costs for all subsequent reinspections shall be borne by the Contractor. If Contractor fails to complete the Punch List work within the thirty (30) Day period, Owner may perform such work and Contractor shall reimburse Owner all costs of the same within ten (10) Days after demand without affecting Contractor's obligations.

I.2 WARRANTY WORK

I.2.1 Neither the final certificate of payment nor any provision of the Contract Documents shall relieve the Contractor from responsibility for defective Work and, unless a longer period is specified, Contractor shall correct all defects that appear in the Work within a period of one year from the date of issuance of the written notice of Substantial Completion by the Owner except for latent defects which will be remedied by the Contractor at any time they become apparent. The Owner shall give Contractor notice of defects with reasonable promptness. Contractor shall perform such warranty work within a reasonable time after Owner's demand. If Contractor fails to complete the warranty work within such period as Owner

determines reasonable, or at any time in the event of warranty work consisting of emergency repairs, Owner may perform such work and Contractor shall reimburse Owner all costs of the same within ten (10) Days after demand, without affecting Contractor's obligations. The Contractor shall perform the warranty Work by correcting defects within twenty-four (24) hours of notification by Owner, unless otherwise specified in the Contract Documents. Should the Contractor fail to respond within the specified response time, the Owner may, at its option, complete the necessary repairs using another contractor or its own forces. If Owner completes the repairs using Owner's own forces, Contractor shall pay Owner at the rate of one and one-half (1½) times the standard hourly rate of Owner's forces, plus related overhead and any direct non-salary costs. If Owner completes the repairs using another contractor, Contractor shall pay Owner the amount of Owner's direct costs billed by the other contractor for the work, plus the direct salary costs and related overhead and direct non-salary expenses of Owner's forces who are required to monitor that contractor's work. Work performed by Owner using Owner's own forces or those of another contractor shall not affect the Contractor's contractual duties under these provisions, including warranty provisions.

- I.2.2 Nothing in this Section I.2 shall negate guarantees or warranties for periods longer than one year including, without limitation, such guarantees or warranties required by other sections of the Contract Documents for specific installations, materials, processes, equipment or fixtures.
- I.2.3 In addition to Contractor's warranty, manufacturer's warranties shall pass to the Owner and shall not take effect until such portion of the Work covered by the applicable warranty has been accepted in writing by the Owner.
- I.2.4 The one-year period for correction of Work shall be extended with respect to portions of Work performed after Substantial Completion by the period of time between Substantial Completion and the actual performance of the Work, and shall be extended by corrective Work performed by the Contractor pursuant to this Section, as to the Work corrected. The Contractor shall remove from the site portions of the Work which are not in accordance with the requirements of the Contract Documents and are neither corrected by the Contractor nor accepted by the Owner.
- I.2.5 Nothing contained in this Section I.2 shall be construed to establish a period of limitation with respect to other obligations which the Contractor might have under the Contract Documents. Establishment of the period for correction of Work as described in this Section I.2 relates only to the specific obligation of the Contractor to correct the Work, and has no relationship to the time within which the obligation to comply with the Contract Documents may be sought to be enforced, nor to the time within which proceedings may be commenced to establish the Contractor's liability with respect to the Contractor's obligations other than specifically to correct the Work.
- I.2.6 If the Owner prefers to accept Work which is not in accordance with the requirements of the Contract Documents, the Owner may do so instead of requiring its removal and correction, in which case the Contract Price will be reduced as appropriate and equitable. Such adjustment shall be effected whether or not final payment has been made.

SECTION J SUSPENSION AND/OR TERMINATION OF THE WORK

J.1 OWNER'S RIGHT TO SUSPEND THE WORK

J.1.1 The Owner has the authority to suspend portions or all of the Work due to the following causes:

- (a) Failure of the Contractor to correct unsafe conditions;
- (b) Failure of the Contractor to carry out any provision of the Contract;
- (c) Failure of the Contractor to carry out orders;
- (d) Conditions, in the opinion of the Owner, which are unsuitable for performing the Work;
- (e) Time required to investigate differing site conditions;
- (f) Any reason considered to be in the public interest.

J.1.2 The Owner shall notify Contractor and the Contractor's Surety in writing of the effective date and time of the suspension, and Owner shall notify Contractor and Contractor's surety in writing to resume Work.

J.2 CONTRACTOR'S RESPONSIBILITIES

- J.2.1 During the period of the suspension, Contractor is responsible to continue maintenance at the project just as if the Work were in progress. This includes, but is not limited to, protection of completed Work, maintenance of access, protection of stored materials, temporary facilities, and clean-up.
- J.2.2 When the Work is recommenced after the suspension, the Contractor shall replace or renew any Work damaged during the suspension, remove any materials or facilities used as part of temporary maintenance, and complete the Work in every respect as though its prosecution had been continuous and without suspension.

J.3 COMPENSATION FOR SUSPENSION

J.3.1 Depending on the reason for suspension of the Work, the Contractor or the Owner may be due compensation by the other party. If the suspension was required due to acts or omissions of Contractor, the Owner may assess the Contractor actual costs of the suspension in terms of administration, remedial work by the Owner's forces or another contractor to correct the problem associated with the suspension, rent of temporary facilities, and other actual costs related to the suspension. If the suspension was caused by acts or omissions of the Owner, the Contractor may be due compensation which shall be defined using Section D, Changes in Work. If the suspension was required through no fault of the Contractor or the Owner, neither party shall owe the other for the impact.

J.4 OWNER'S RIGHT TO TERMINATE CONTRACT

- J.4.1 The Owner may, without prejudice to any other right or remedy, and after giving Contractor seven (7) Days' written notice and an opportunity to cure, terminate the Contract in whole or in part under the following conditions:
 - (a) If Contractor should, voluntarily or involuntarily, seek protection under the United States Bankruptcy Code and Contractor as debtor-in-possession or the Trustee for the estate fails to assume the Contract within a reasonable time;
 - (b) If Contractor should make a general assignment for the benefit of Contractor's creditors;
 - (c) If a receiver should be appointed on account of Contractor's insolvency;
 - (d) If Contractor should repeatedly refuse or fail to supply an adequate number of skilled workers or proper materials to carry on the Work as required by the Contract Documents, or otherwise fail to perform the Work in a timely manner;

- (e) If Contractor should repeatedly fail to make prompt payment to Subcontractors or for material or labor, or should disregard laws, ordinances or the instructions of the Owner; or
- (f) If Contractor is otherwise in breach of any part of the Contract.
- (g) If Contractor is in violation of Applicable Laws, either in the conduct of its business or in its performance of the Work.

J.4.2 At any time that any of the above occurs, Owner may exercise all rights and remedies available to Owner at law or in equity, and, in addition, Owner may take possession of the premises and of all materials and appliances and finish the Work by whatever method it may deem expedient. In such case, the Contractor shall not be entitled to receive further payment until the Work is completed. If the Owner's cost of finishing the Work exceeds the unpaid balance of the Contract Price, Contractor shall pay the difference to the Owner.

J.5 TERMINATION FOR CONVENIENCE

- J.5.1 Owner may terminate the Contract in whole or in part whenever Owner determines that termination of the Contract is in the best interest of Owner or the public.
- J.5.2 The Owner shall provide the Contractor with seven (7) Days prior written notice of a termination for Owner's or for public convenience. After such notice, the Contractor shall provide the Owner with immediate and peaceful possession of the premises and materials located on and off the premises for which the Contractor received progress payment under Section E. Compensation for Work terminated by the Owner under this provision will be according to Section E. In no circumstance shall Contractor be entitled to lost profits for Work not performed due to termination.

J.6 ACTION UPON TERMINATION

- J.6.1 Upon receiving a notice of termination, and except as directed otherwise by the Owner, Contractor shall immediately cease placing further subcontracts or orders for materials, services, or facilities. In addition, Contractor shall terminate all subcontracts or orders to the extent they relate to the Work terminated and, with the prior written approval of the Owner, settle all outstanding liabilities and termination settlement proposals arising from the termination of subcontracts and orders.
- J.6.2 As directed by the Owner, Contractor shall, upon termination, transfer title and deliver to the Owner all Record Documents, information, and other property that, if the Contract had been completed, would have been required to be furnished to the Owner.

I.6.3 Upon Owner's notice of termination pursuant to either Section J.4 or J.5, if Owner shall so elect, Contractor shall assign to the Owner such subcontracts and orders as Owner shall specify. In the event Owner elects to take assignment of any such subcontract or order, Contractor shall take such action and shall execute such documents as Owner shall reasonably require for the effectiveness of such assignment and Contractor shall ensure that no contractual arrangement between it and its subcontractors or suppliers of any tier or sub-tier shall prevent such assignment.

**SECTION K
CONTRACT CLOSE OUT**

K.1 RECORD DOCUMENTS

As a condition of final payment (and subject to the provisions of section E.6), Contractor shall comply with the following: Contractor shall provide Record Documents for the entire project to Owner. Record Documents shall depict the project as constructed and shall reflect each and every change, modification, and deletion made during the construction. Record Documents are part of the Work and shall be provided prior to the Owner's issuance of final payment. Record Documents include all modifications to the Contract Documents, unless otherwise directed, and accurate MWESB Reports.

K.2 OPERATION AND MAINTENANCE MANUALS

As part of the Work, Contractor shall submit two completed operation and maintenance manuals ("O & M Manuals") for review by the Owner prior to submission of any pay request for more than 75% of the Work. Owner's receipt of the O & M Manuals shall be a condition precedent to any payment thereafter due. The O & M Manuals shall contain a complete set of all submittals, all product data as required by the specifications, training information, telephone list and contact information for all consultants, manufacturers, installer and suppliers, manufacturer's printed data, record and shop drawings, schematic diagrams of systems, appropriate equipment indices, warranties and bonds. The Owner shall review and return one O & M Manual for any modifications or adjustments required. Prior to submission of its final pay request, Contractor shall deliver three complete and approved sets of O & M Manuals in paper form and one complete and approved set in electronic form to the Owner and Owner's receipt of the O & M Manuals shall be a condition precedent to Owner's obligation to make final payment.

K.3 COMPLETION NOTICES

K.3.1 Contractor shall provide Owner written notice of both Substantial and Final Completion. The certificate of Substantial Completion shall state the date of Substantial Completion, the responsibilities of the Owner and Contractor for security, maintenance, heat, utilities, damage to the Work and insurance, and the time within which the Contractor shall finish all items on the Punch List accompanying the Certificate. Both completion notices must be signed by the Contractor and the Owner to be valid. The Owner shall provide the final signature on the approved notices. The notices shall take effect on the date they are signed by the Owner.

K.3.2 Substantial Completion of a facility with operating systems (e.g., mechanical, electrical, HVAC) shall be that degree of completion that has provided a minimum of thirty (30) continuous Days of successful, trouble-free operation, which period shall begin after all performance and acceptance testing has been successfully demonstrated to the Owner. All equipment contained in the Work, plus all other components necessary to enable the Owner to operate the facility in the manner that was intended, shall be complete on the Substantial Completion date. The Contractor may request that a Punch List be prepared by the Owner with submission of the request for the Substantial Completion notice.

K.4 TRAINING

As part of the Work, and prior to submission of the final application for payment, the Contractor shall schedule with the Owner training sessions for all equipment and systems as required by the Contract Documents. Contractor shall schedule training sessions at least two weeks in advance of the date of training to allow Owner to provide its personnel with adequate notice. The O & M Manual shall be used as a basis for training. Training shall be a formal session conducted at the Work site, or as required by the Contract Documents, after the equipment and/or system is completely installed and operational in its normal operating environment.

K.5 EXTRA MATERIALS

As part of the Work, Contractor shall provide spare parts, extra maintenance materials, and other materials or products in the quantities specified in the Contract Documents prior to final payment. Delivery point for extra materials shall be designated by the Owner.

K.6 ENVIRONMENTAL CLEAN-UP

As part of the Final Completion notice, or as a separate written notice submitted with or before the notice of Final Completion, the Contractor shall notify the Owner that all environmental and pollution clean-up, remediation and closure have been completed in accordance with all Applicable Laws and pursuant to the authority of all agencies having jurisdiction, and Contractor shall provide Owner with any and all documentation related to the same, including but not limited to directives, orders, letters, certificates and permits related to or arising from such environmental pollution. The notice shall reaffirm the indemnification given under Section F.5.1 above. Contractor's completion of its obligations under this Section K.6 and Owner's receipt of documents evidencing such completion shall be a condition precedent to Owner's obligation to make final payment.

K.7 CERTIFICATE OF OCCUPANCY

Owner's receipt of an unconditioned certificate of occupancy from the appropriate state and/or local building officials shall be a condition precedent to Owner's obligation to make final payment, except to the extent failure to obtain an unconditional certificate of occupancy is due to the fault or neglect of Owner.

K.8 OTHER CONTRACTOR RESPONSIBILITIES

The Contractor shall be responsible for returning to the Owner all property of Owner issued to Contractor during construction such as keys, security passes, site admittance badges, and all other pertinent items. Upon notice from Owner, Contractor shall be responsible for notifying the appropriate utility companies to transfer utility charges from the Contractor to the Owner. The utility transfer date shall not be before Substantial Completion and may not be until Final Completion, if the Owner does not take beneficial use of the facility and the Contractor's forces continue with the Work.

K.9 SURVIVAL

All warranty and indemnification provisions of this Contract, and all of Contractor's other obligations under this Contract that are not fully performed by the time of Final Completion or termination, shall survive Final Completion or any termination of the Contract.

OREGON UNIVERSITY SYSTEM

SUPPLEMENTAL GENERAL CONDITIONS

To The

GENERAL CONDITIONS

FOR PUBLIC IMPROVEMENT CONTRACTS

Contract No. 2014-0327
Cox Hall Fire Alarm/Mass Notification System

The following modify the Oregon University System “General Conditions for Public Improvement Contracts”, July 1, 2012, (OUS General Conditions) for this Contract. Where a portion of the OUS General Conditions is modified by these Supplemental General Conditions, the unaltered portions shall remain in effect.

SG-1. Section B.2.2 is modified as follows: Add the following:

"Should the Contractor request the assistance of Owner in the performance of any Work included in the Contract Documents, and should Owner, at its discretion, agree to provide such assistance, Owner may provide such assistance by using its own forces or by using another contractor. If Owner performs Work using Owner's own forces, Contractor shall pay Owner at the rate of one and one-half (1½) times the standard hourly rate of Owner's forces, plus related overhead and any direct non-salary costs. If Owner performs the Work using another contractor, Contractor shall pay Owner the amount of Owner's direct costs billed by the other contractor for the Work performed, plus the direct salary costs and related overhead and direct non-salary expenses of Owner's forces who are required to monitor that contractor's work. Work performed by Owner using Owner's own forces or those of another contractor shall not affect the Contractor's contractual duties under these provisions, including warranty provisions."

SG-2. Section B.4 is modified as follows: Revise to read:

“Contractor shall obtain and pay for all necessary permits and licenses, except for those specifically excluded in the Supplemental General Conditions, for the construction of the Work, for temporary obstructions, enclosures, opening of streets for pipes, walls, utilities, environmental Work, etc., as required for the project. Owner shall obtain and pay for the general building permit and pay for any specialty permits required for the Work. Contractor shall be responsible for all violations of the law, in connection with the construction or caused by obstructing streets, sidewalks or otherwise. Contractor shall give all requisite

notices to public authorities. The Contractor shall pay all royalties and license fees. The Contractor shall defend all suits or claims for infringement of any patent or other proprietary rights and save harmless and blameless from loss, on account thereof, the State of Oregon, and its departments, divisions, members and employees.”

SG-3. Section E.2.9 is modified as follows: Add the following:

“Owner shall provide the Contractor with an electronic version of the desired reporting format at the time of execution of the Contract or GMP Amendment for the Contractor’s use in submittal of the report, which should be submitted both electronically and in hard copy.”

SG-4. Section F.2.4 is modified as follows: Add the following:

“Contractor shall verify that all mechanical or electrical equipment in the construction areas that may be affected by the Work is in working order and shall notify the Owner, in writing, of any equipment not in working order prior to the start of the Work. Start of Work will be considered as acknowledgement that all equipment is in good working order. Contractor shall be required to restore equipment to its original, or better, condition upon completion of the project.”

SG-5. Section G.3.4.1 is modified as follows: Replace the last two sentences of with the following:

"Combined single limit per occurrence shall not be less than \$5 million per occurrence, or the equivalent. Each annual aggregate limit shall not be less than \$5 million, when applicable. Should Contractor require Subcontractors to provide Commercial General Liability coverage for the benefit of Contractor, Contractor shall not require coverage in an amount exceeding \$2 million per occurrence, or the equivalent."

SG-6. Section G.3 is modified as follows: Add the following G.3.4.4:

“Professional Liability: Prior to the beginning of any work on Design Build Components, the Contractor shall provide to the Owner certificates of insurance for Commercial General Liability in an amount not less than \$1,000,000, including Product Liability and Completed Operations, from the manufacturers of Design Build components, unless such Design/Build components are “off-the-shelf” products purchased from a supplier. All such certificates shall be in compliance with the Owner’s contract requirements.

For those elements requiring design or calculations performed by a professional engineer, the Contractor shall obtain from the Engineer, if not an employee of Contractor, and provide to the Owner, similar certificates of Commercial General

Liability coverage. The Engineer shall also provide the Owner with proof of coverage for Professional Liability insurance covering any damages caused by any negligent error, omission, or any act for the project, its drawings and specifications, and all related work products of the Engineer. The policy may be either a practice based policy or a policy pertaining to the specific project. Professional Liability insurance to be provided shall have a combined single limit of not less than \$1,000,000.”

SG-7. Section H.2.1 is deleted and replaced with the following:

"Contractor shall provide, by or before the pre-construction conference, a detailed project Work schedule for review and acceptance by the Owner. The submitted schedule must illustrate Work by significant project components, significant labor trades, long lead items, broken down by building and/or floor where applicable. Each schedule item shall account for no greater than 5% of the monetary value of the project or 5% of the available time. Schedules with activities of less than one day or valued at less than 1% of the Contract shall be considered too detailed and shall not be accepted. Schedules lacking adequate detail, or unreasonably detailed, shall be rejected. Included within the schedule are the following: Notice to Proceed, Substantial Completion, and Final Completion. Contractor shall provide an updated, full project schedule with each payment request. In addition, twice monthly, the Contractor shall provide an updated three-week forward-looking schedule. Acceptance of the Schedule by the Owner does not constitute agreement by the Owner as to the Contractor's sequencing, means, methods, or durations. Any positive difference between the Contractor's scheduled completion and the contract completion date is float owned by the Owner. Use of the float shall be negotiated. In no case shall the Contractor make a claim for delays if the Work is completed within the Contract Period but after Contractor's scheduled completion."

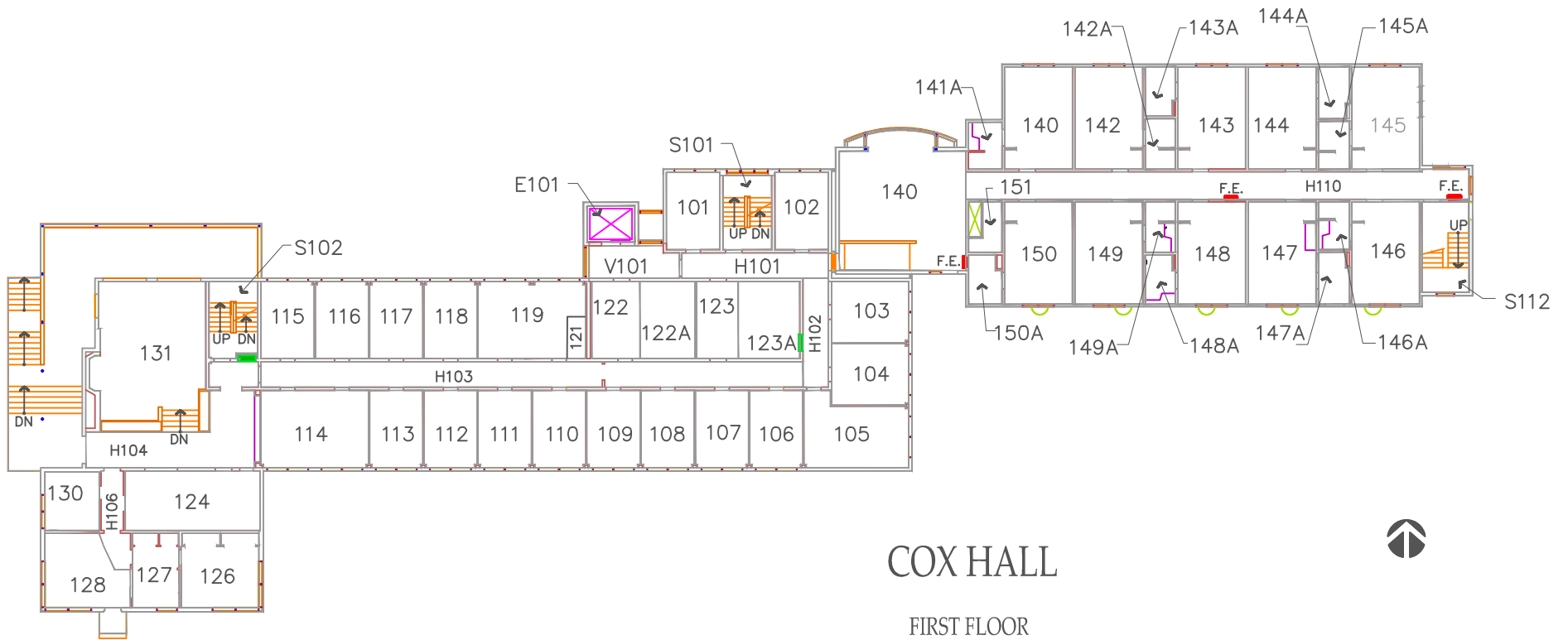

COX HALL

FIRST FLOOR

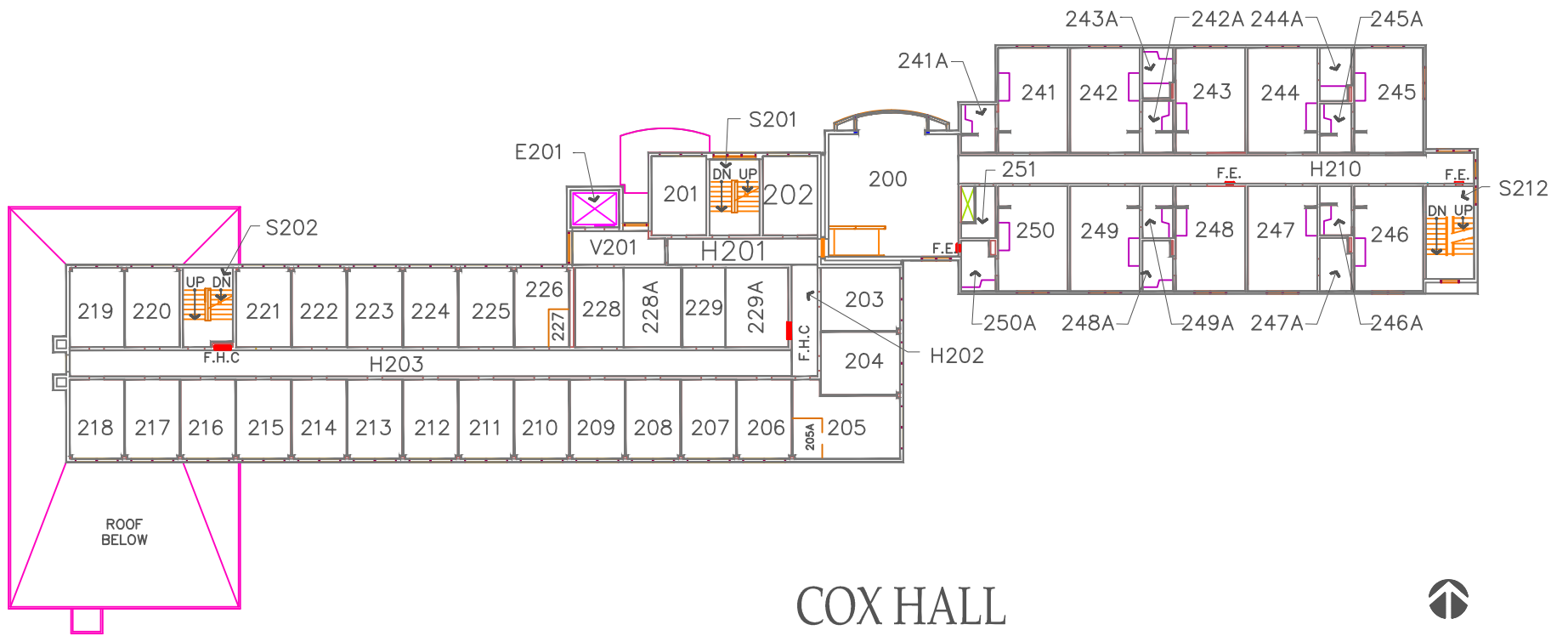

COX HALL
SECOND FLOOR



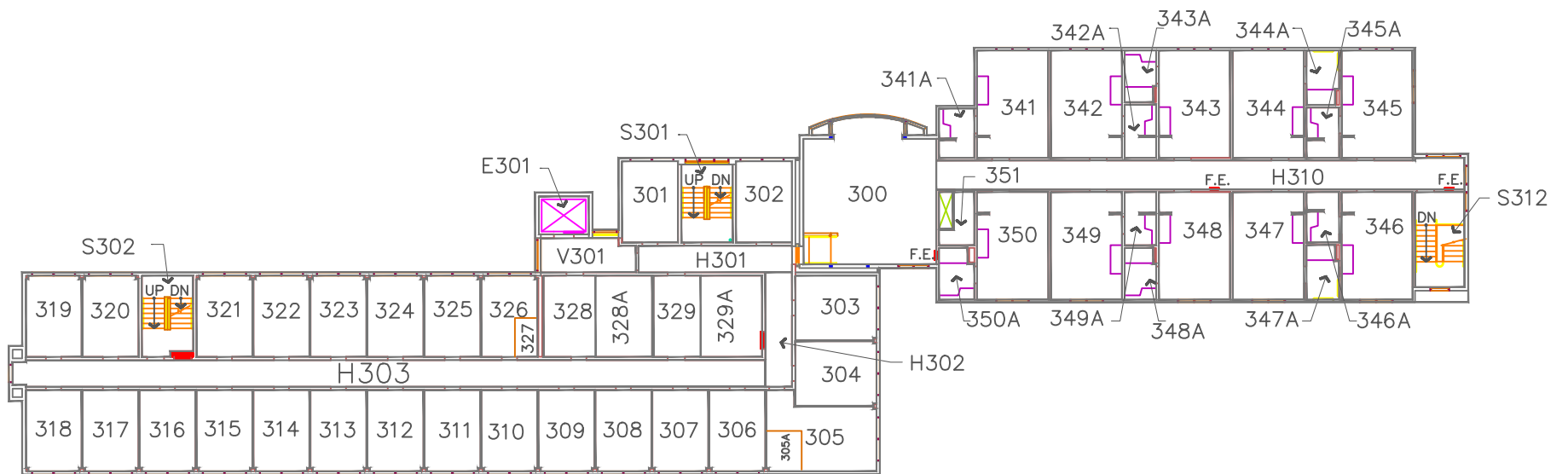

COX HALL
THIRD FLOOR

FIRE ALARM SYSTEM OPERATIONAL MATRIX		ALARM	TRouble	Supervisory	MISC.	REMARKS
SMOKE DETECTORS	INITIATOR	•	•	•	•	SMOKE DETECTOR TRIGGERED
DUCT DETECTORS	INITIATOR	•	•	•	•	DUCT DETECTOR TRIGGERED
WATERFLOW SWITCH	INITIATOR	•	•	•	•	WATERFLOW SWITCH TRIGGERED
SIGNAL SERVICE	INITIATOR	•	•	•	•	SIGNAL SERVICE TRIGGERED
FIRE ALARM TROUBLE (OPEN, SHORTS, OR GROUNDING) ON INITIATOR OR SIGNALING CIRCUITS	INITIATOR	•	•	•	•	FIRE ALARM TROUBLE
SMOKE DETECTOR SHUTS DOWN INDIVIDUAL UNIT ONLY.	INITIATOR	•	•	•	•	SMOKE DETECTOR SHUTS DOWN
ONLY LOCAL AREA SMOKE DETECTORS ACTIVATE DAMPER SHUT DOWN.	INITIATOR	•	•	•	•	LOCAL SMOKE DETECTOR SHUTS DOWN

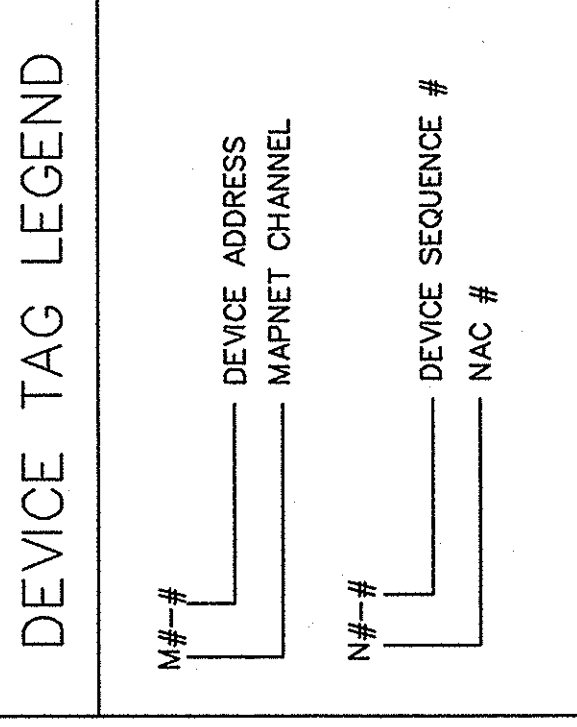

GENERAL NOTES

- THE FIRE ALARM SYSTEM SHALL CONFORM TO NFPA 72 AND NFPA 70, ARTICLE 760.
- UPON COMPLETION OF THE INSTALLATION OF THE FIRE ALARM SYSTEM, A SATISFACTORY TEST OF THE ENTIRE SYSTEM SHALL BE MADE IN THE PRESENCE OF THE FIRE MARSHAL.
- A MINIMUM OF 48 HOURS NOTICE SHALL BE REQUIRED FOR ANY INSPECTION AND/OR TESTING.
- A CERTIFICATE OF COMPLIANCE SHALL BE PREPARED BY THE INSTALLER AND GIVEN TO THE FIRE MARSHAL UPON COMPLETION OF THE INSTALLATION.

WIRE/CABLE SCHEDULE

SYMBOL	WIRE	USE
M	1) #18 AWG TWISTED SHIELDED PAIR	INNET
N	2) #14 AWG	NOTIFICATION APPLIANCE
P	2) #14 AWG	24VDC POWER
Z	2) #18 AWG	CONTACT CLOSURE DEVICE
D	2) #14 AWG	DOOR HOLDERS

NOTES:

- DUCT DETECTOR SHUTS DOWN INDIVIDUAL UNIT ONLY.
- ONLY LOCAL AREA SMOKE DETECTORS ACTIVATE DAMPER SHUT DOWN.

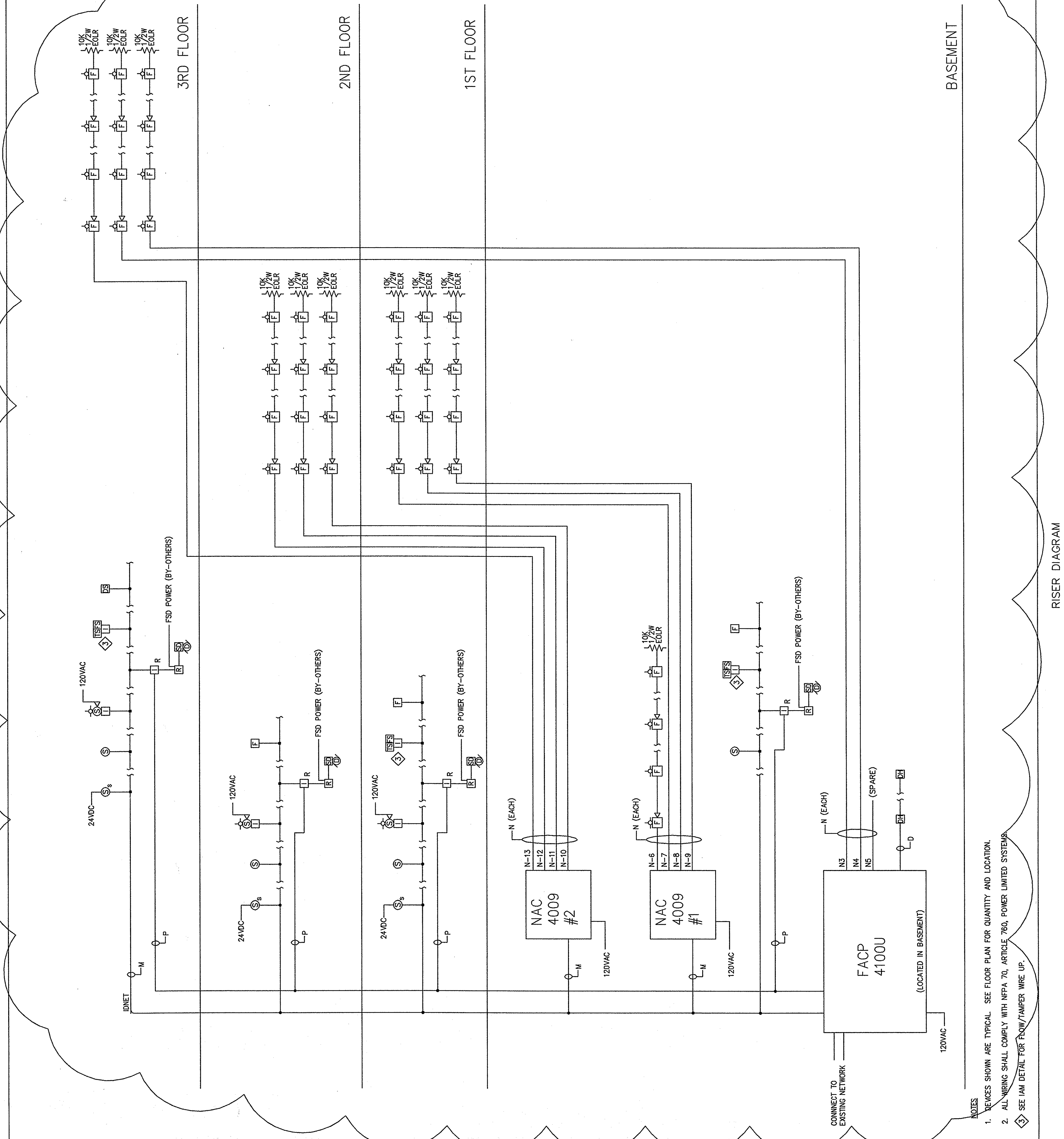

NOTES:

- DEVICES SHOWN ARE TYPICAL. SEE FLOOR PLAN FOR QUANTITY AND LOCATION.
- ALL WIRING SHALL COMPLY WITH NFPA 70, ARTICLE 760. POWER LIMITED SYSTEMS.

SEE IAM DETAIL FOR PAIN/TAMPER WIRE UP.

SYMBOL KEY

SYMBOL	DESCRIPTION	MODEL #	BACKBOX
[E] [E]	4100U FIRE ALARM CONTROL PANEL NETWORK INTERFACE CARD - MODULAR NETWORK MEDIA CARD - WRED BATTERY 18AH	4100-9111 4100-8014 4100-8056 2081-8275	24" W x 40" H x 6-29/32" D
[M] [M]	4009 INNET NAC EXTENDER, 120 VAC BATTERY 6.2AH	4009-8201 2081-8272	16-1/4" W x 13-1/2" H x 4-3/16" D
[F] [F]	INNET SINGLE ACTION PULL STATION	4089-9001	1-GANG x 2-1/2"
[S] [S]	TRIEALARM PHOTO SMOKE SENSOR W/ TRIEALARM SENSOR BASE	4088-9714 4088-9792	4" OCTAGONAL x 1-1/2"
[S] [S]	TRIEALARM PHOTO SMOKE SENSOR W/ TRIEALARM SENSOR SOUNDER BASE	4088-9714 4088-9794	4" OCTAGONAL x 1-1/2"
[S] [S]	GENEX SMOKE DETECTOR	7109CS-C	4" OCTAGONAL x 1-1/2"
[S] [S]	TRIEALARM DUCT SMOKE SENSOR W/ RELAY OUTPUT W/ ENCAPSULATED RELAY	4088-9756 4088-8843	SELF CONTAINED, NEMA 1, MOUNT TO SIDE OF DUCT 1-GANG x 2-1/2" MINIMUM, LOCATE WITHIN 3' OF DEVICE CONTROLLED
[S] [S]	W/ SAMPLING TUBE 48"	2088-9797	
[R] [R]	INNET RELAY IAM	4080-9002	4" SQUARE x 2-1/8" W/ BLANK COVER PLATE
[R] [R]	INNET SUPERVISED IAM	4080-9001	SINGLE GANG 2-1/2" W/ BLANK COVER PLATE
[R] [R]	10A RELAY SPOT W/ ENCLOSURE	2088-9008	3-1/8" W x 6-1/8" H x 2-1/2" D
[R] [R]	TRIEALERT 1500 AUDIBLE/VISIBLE RED	4803-9417	4" SQUARE OR 1-GANG OR 2-GANGS, 1-1/2" D
[R] [R]	TRIEALERT 7500 AUDIBLE/VISIBLE RED	4803-9418	4" SQUARE OR 1-GANG OR 2-GANGS, 1-1/2" D
[R] [R]	TRIEALERT 11000 AUDIBLE/VISIBLE RED	4803-9419	4" SQUARE OR 1-GANG OR 2-GANGS, 1-1/2" D
[R] [R]	TRIEALERT 1500 VISIBLE ONLY RED	4804-9331	4" SQUARE OR 1-GANG OR 2-GANGS, 1-1/2" D
[S] [S]	TAMPER SWITCH	BY-OTHERS	
[S] [S]	FLOW SWITCH	BY-OTHERS	
[S] [S]	FIRE SMOKE DAMPER	BY-OTHERS	
[R] [R]	DOOR HOLDER	BY-OTHERS	

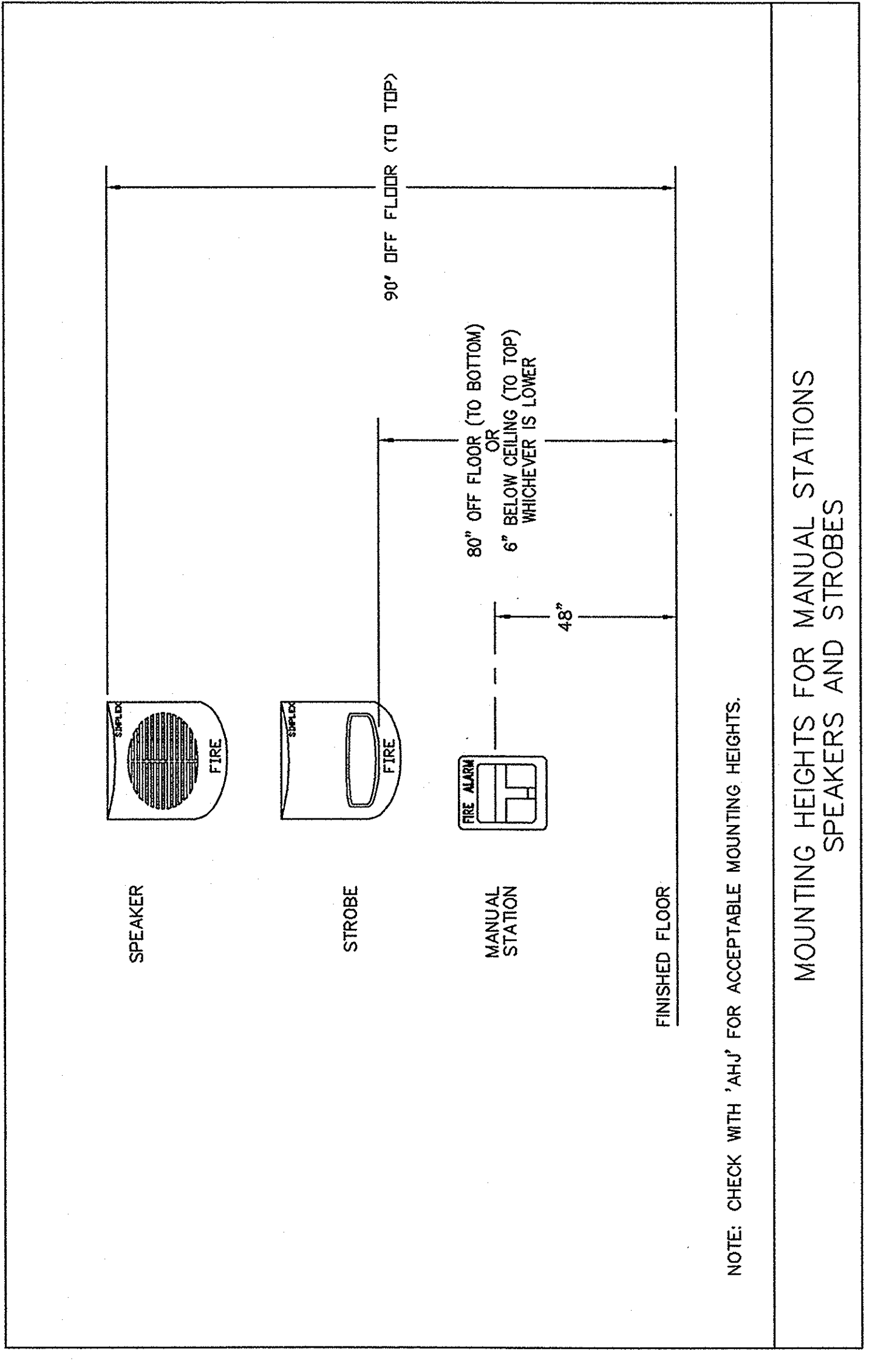

MOUNTING HEIGHTS FOR MANUAL STATIONS, SPEAKERS AND STROBES

NOTE: CHECK WITH 'AHJ' FOR ACCEPTABLE MOUNTING HEIGHTS.

- ALL EQUIPMENT MUST BE INSTALLED IN ACCORDANCE WITH THE MANUFACTURER'S RECOMMENDATIONS AND THE SPECIFICATIONS AND THE INSTALLATION OF ALL WIRING, CABLE AND EQUIPMENT MUST BE IN ACCORDANCE WITH NFPA 70, NATIONAL ELECTRICAL CODE, AND SPECIFICALLY WITH ARTICLE 760, FIRE ALARM PROTECTIVE SIGNALING SYSTEMS; ARTICLE 770, OPTICAL FIBER CABLES; AND ARTICLE 780, UNDERGROUND WIRING. ALL WIRING MUST BE PROTECTED AGAINST MECHANICAL INJURY IN ACCORDANCE WITH ARTICLE 760.
- WHERE SHIELDED WIRE IS USED, THE FOLLOWING MUST BE OBSERVED:
 - THE ENTIRE LENGTH OF THE CABLE MUST BE MAINTAINED THROUGHOUT THE ENTIRE LENGTH OF THE CABLE.
 - THE ENTIRE LENGTH OF THE CABLE MUST HAVE A RESISTANCE GREATER THAN 1 MEGOHM TO EARTH GROUND.
- UNDERGROUND WIRING MUST BE FREE OF ALL WATER.
- IN AREAS OF HIGH LIGHTNING ACTIVITY OR WHERE LARGE POWER SURGES ARE PRESENT, COMPATIBLE TRANSIENT SUPPRESSOR DEVICES MAY BE USED (CONSULT YOUR LOCAL SIMPLEX BRANCH OFFICE FOR COMPATIBLE DEVICES).
- WIRING OTHER THAN THAT CONNECTED TO ELEVATOR CABLES MUST NOT BE RUN IN ELEVATOR SHAFTS (REF: NFPA 70, ARTICLE 620-37).
- WITH NFPA ARTICLE 30-22.
- SPlicing IS PERMITTED. CONDUCTORS SHALL BE SPliced OR JOINED WITH APPROVED SPlicing DEVICES OR OTHER APPROVED METHODS.
- A SYSTEM GROUND MUST BE PROVIDED FOR EARTH DETECTION AND TRANSIENT SUPPRESSION. THIS CONNECTION MUST BE MADE TO AN APPROVED DEDICATED EARTH CONNECTION IN ACCORDANCE WITH NFPA 70, ARTICLE 250.
- ONLY SYSTEM WIRING CAN BE RUN IN THE SHAPE CONDUIT.
- POWER AND NOTIFICATION WIRING MUST BE SEPARATED BY A MINIMUM OF 18 INCHES FROM THE WIRING OF OTHER SYSTEMS. ALL CIRCUITS ARE POWER LIMITED EXCEPT FOR AC POWER, BATTERY AND CITY CIRCUIT.
- INITIATING CIRCUITS AND NOTIFICATION CIRCUITS MUST NOT LEAVE THE BUILDING OF ORIGIN UNLESS THE APPLICABLE FOLLOWING CONDITIONS ARE MET:
 - UNDERGROUND WIRING: 1) THE CIRCUITS ARE PROTECTED FROM LIGHTNING BY UTILIZATION OF A LIGHTNING PROTECTIVE SYSTEM (LPS) OR 2) RUN SEPARATELY AND IN PARALLEL FROM ANY COMMERCIAL POWER DISTRIBUTION WIRING.
 - OVERHEAD WIRING: 1) THE CIRCUITS ARE PROTECTED FROM LIGHTNING BY UTILIZATION OF A LISTED ISOLATED LOOP CIRCUIT PROTECTOR, 2) THE OUTSIDE PLANT WIRING IS LIMITED TO ONE CONTIGUOUS WIRING RUN IN PARALLEL WITH RELATION TO THE COMMERCIAL POWER DISTRIBUTION WIRING AND BE SEPARATED BY A MINIMUM DISTANCE OF (WHICHEVER IS GREATER) 100 FEET OR THE MAXIMUM SPAN BETWEEN TWO ADJACENT POLES OF THE SYSTEMS. 3) THE MAXIMUM SPAN BETWEEN ADJACENT POLES IS 250 FT. 4) THE MAXIMUM TOTAL WIRE LENGTH FOR STYLE 4 IS 2,500 FT. MAXIMUM TOTAL WIRE LENGTH FOR STYLE 4 IS 10,000 FT. MAXIMUM TOTAL WIRE LENGTH FOR STYLE 6 (NO T-TAPPING) IS 2,500 FT.

tyco Fire & Security
SimplexGrinnell

6305 SW ROSEWOOD ST
LAKE OSWEGO, OR 97036
SALES: 1-800-846-1788
SERVICE: 1-800-873-0085
FAX: 503-675-8521

REV.	DATE	ISSUE COMMENTS
0	07/03/02	

SCALE: NONE
FIRE/LIFE SAFETY SYSTEM
INFORMATION SHEET

ASHLAND, OREGON
SOUTHERN OREGON UNIVERSITY
COX HALL
PROJECT # 42000099
SIS-FA1DWG
FA-1
SHEET 1 OF 11

ASHLAND, OREGON
SOUTHERN OREGON UNIVERSITY
COX HALL

FIRE/LIFE SAFETY SYSTEM
FIRE ALARM DEVICE PLACEMENT PLAN

SCALE: 1/8" = 1'-0"

CHK'D	DRN	DATE	ISSUE COMMENTS	REV.
		07/09/02	FOR APPROVAL	0

tyco Fire & Security
 6905 SW ROSEWOOD ST.
 LAKE OSWEGO, OR 97035
 1-800-873-0085
 503-675-8521

© 2002 SIMPLEXGRINELL LP
 ALL RIGHTS RESERVED

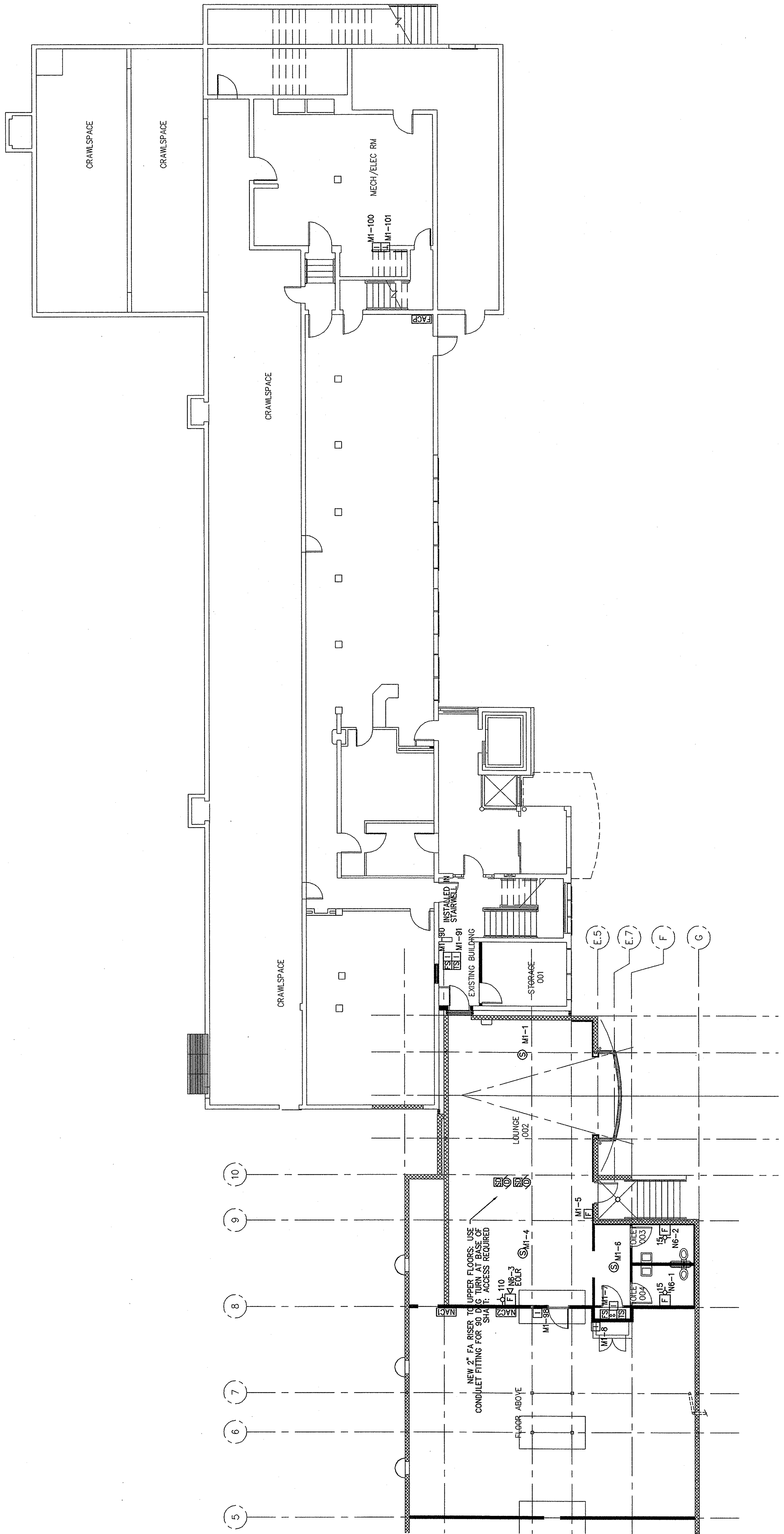

BASEMENT
 1/8" = 1'-0"

COX HALL
SOUTHERN OREGON UNIVERSITY
ASHLAND, OREGON

FIRE/LIFE SAFETY SYSTEM
FIRE ALARM DEVICE PLACEMENT PLAN

SCALE: 1/8" = 1'-0"

REV.	ISSUE COMMENTS	DATE	CHK'D	DRN
0	FOR APPROVAL	07/09/02	KC	BKA
1	AS BUILDS PER JCI	02/05/03	JCI	BKA

SALES: 1-800-848-1786
 SERVICE: 1-800-873-0085
 FAX: 503-876-6521
 6305 SW ROSEWOOD ST.
 LAKE OSWEGO, OR 97036

tyco Fire & Security
SimplexGrinnell

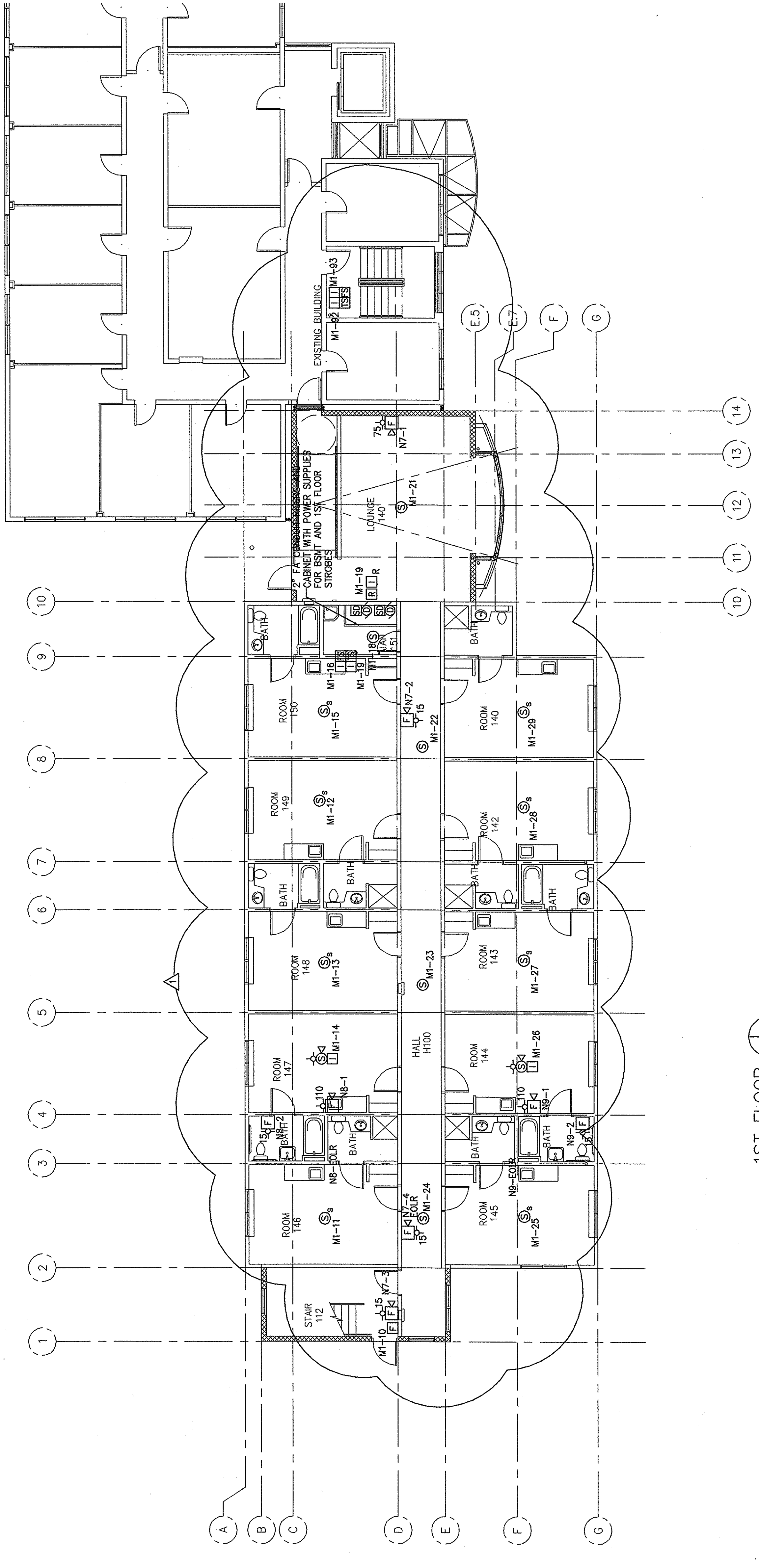

1ST FLOOR
 1/8" = 1'-0"

COX HALL

SOUTHERN OREGON UNIVERSITY

SCALE: 1/8" = 1'-0"

FIRE/LIFE SAFETY SYSTEM

FIRE ALARM DEVICE PLACEMENT PLAN

REV.	ISSUE COMMENTS	CHK'D	DRN	DATE
0		KC	BKA	07/09/02
1		JCI	BKA	02/06/03

6305 SW ROSEWOOD ST
LAKE OSWEGO, OR 97035

SALES: 1-800-946-1785
SERVICE: 1-800-973-0085
FAX: 503-675-8521

tyco Fire & Security
SimplexGrinnell

© 2002 SIMPLEXGRINNELL, LP
ALL RIGHTS RESERVED

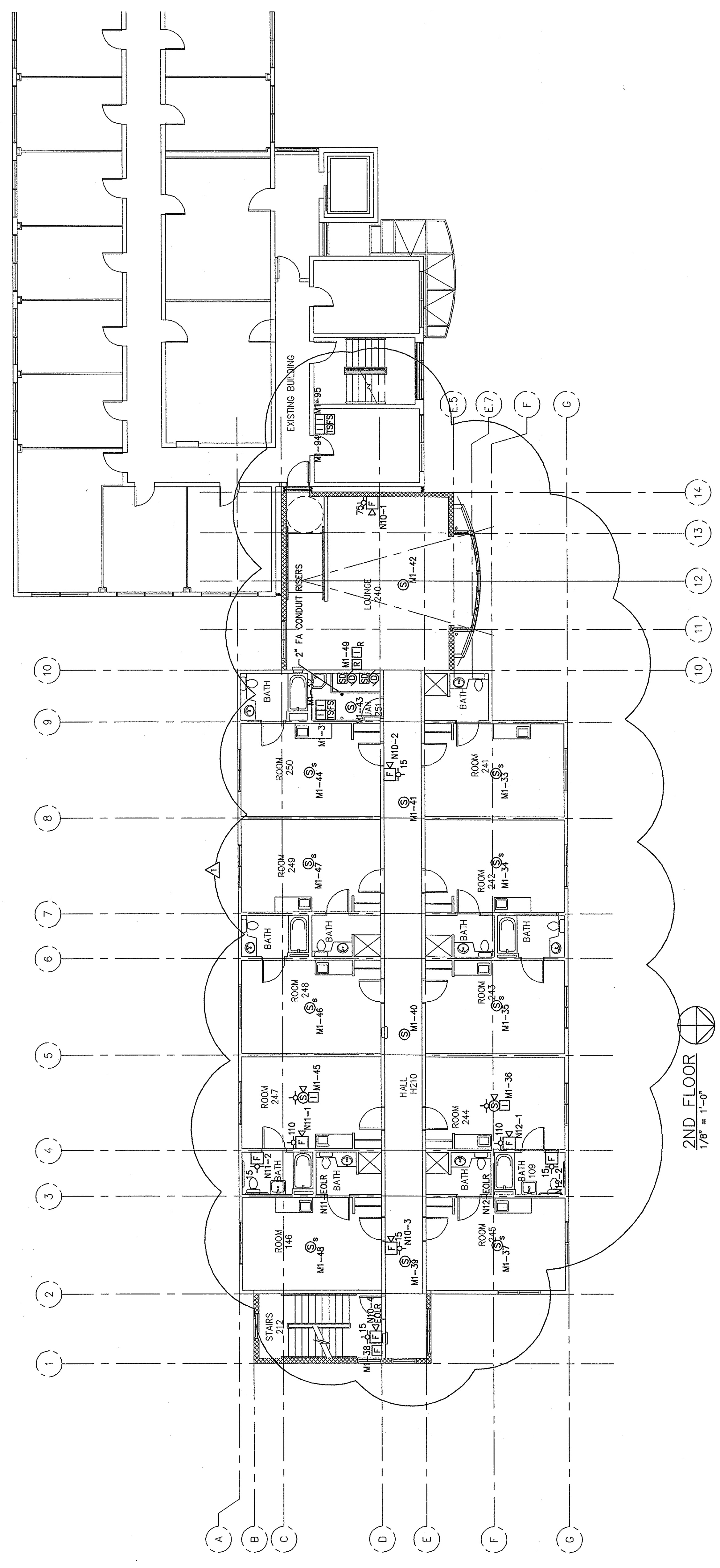

COX HALL SOUTHERN OREGON UNIVERSITY

FIRE/LIFE SAFETY SYSTEM FIRE ALARM DEVICE PLACEMENT PLAN

SCALE: 1/8" = 1'-0"

REV.	DATE	ISSUE COMMENTS
1	07/09/02	FOR APPROVAL
0	02/05/03	AS BUILDS PER JCI

tyco Fire & Security
 8305 SW ROSEWOOD ST.
 LAKE OSWEGO, OR 97035
 SALES: 1-800-846-1785
 SERVICE: 1-800-873-0085
 FAX: 503-675-6521

©2002 SIMPLEXGRINELL, LP
 ALL RIGHTS RESERVED

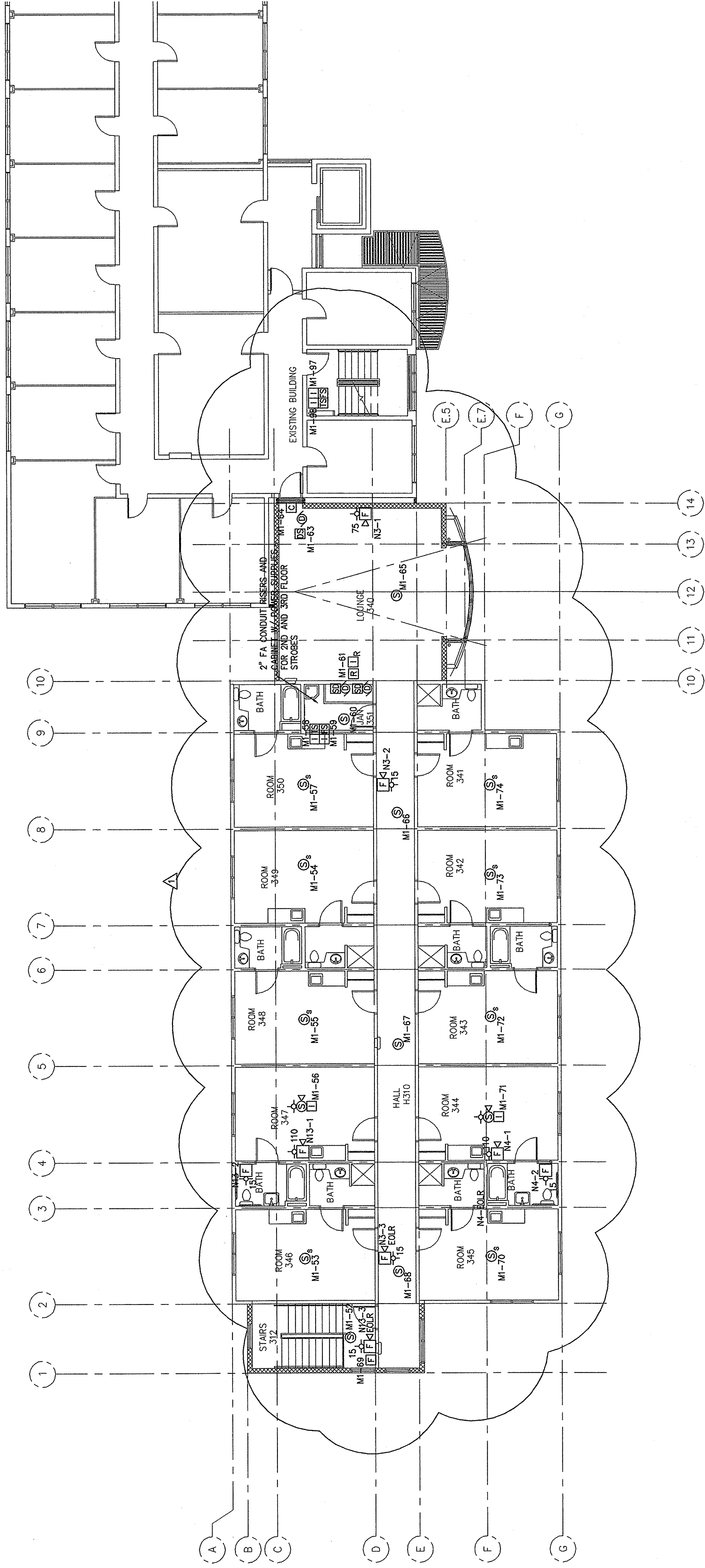

3RD FLOOR
 1/8" = 1'-0"

IDENT 1 POINT LIST

ADDRESS	DEV TYPE	POINT TYPE	LABEL
M1-1	PHOTO	SMOKE	COX GRAND SD LOUNGE
M1-2	PHOTO	SMOKE	SPARE
M1-3	PHOTO	SMOKE	COX GRAND SD LOUNGE
M1-4	PHOTO	PULL	COX GRAND SD LOUNGE
M1-5	ASBRPL	SMOKE	COX GRAND SD LOUNGE
M1-6	PHOTO	SMOKE	COX GRAND SD LOUNGE
M1-7	IAM	SMOKE	COX GRAND SD LOUNGE
M1-8	IAM	SMOKE	COX GRAND SD LOUNGE
M1-9	IAM	SMOKE	COX GRAND SD LOUNGE
M1-10	ASBRPL	SMOKE	COX GRAND SD LOUNGE
M1-11	PHOTO	SMOKE	COX GRAND SD LOUNGE
M1-12	PHOTO	SMOKE	COX GRAND SD LOUNGE
M1-13	PHOTO	SMOKE	COX GRAND SD LOUNGE
M1-14	IAM	SMOKE	COX GRAND SD LOUNGE
M1-15	IAM	SMOKE	COX GRAND SD LOUNGE
M1-16	IAM	SMOKE	COX GRAND SD LOUNGE
M1-17	IAM	SMOKE	COX GRAND SD LOUNGE
M1-18	PHOTO	SMOKE	COX GRAND SD LOUNGE
M1-19	PHOTO	SMOKE	COX GRAND SD LOUNGE
M1-20	PHOTO	SMOKE	COX GRAND SD LOUNGE
M1-21	PHOTO	SMOKE	COX GRAND SD LOUNGE
M1-22	PHOTO	SMOKE	COX GRAND SD LOUNGE
M1-23	PHOTO	SMOKE	COX GRAND SD LOUNGE
M1-24	PHOTO	SMOKE	COX GRAND SD LOUNGE
M1-25	PHOTO	SMOKE	COX GRAND SD LOUNGE
M1-26	IAM	SMOKE	COX GRAND SD LOUNGE
M1-27	PHOTO	SMOKE	COX GRAND SD LOUNGE
M1-28	PHOTO	SMOKE	COX GRAND SD LOUNGE
M1-29	PHOTO	SMOKE	COX GRAND SD LOUNGE
M1-30	PHOTO	SMOKE	COX GRAND SD LOUNGE
M1-31	IAM	SMOKE	COX GRAND SD LOUNGE
M1-32	IAM	SMOKE	COX GRAND SD LOUNGE
M1-33	PHOTO	SMOKE	COX GRAND SD LOUNGE
M1-34	PHOTO	SMOKE	COX GRAND SD LOUNGE
M1-35	PHOTO	SMOKE	COX GRAND SD LOUNGE
M1-36	PHOTO	SMOKE	COX GRAND SD LOUNGE
M1-37	PHOTO	SMOKE	COX GRAND SD LOUNGE
M1-38	PHOTO	SMOKE	COX GRAND SD LOUNGE
M1-39	PHOTO	SMOKE	COX GRAND SD LOUNGE
M1-40	PHOTO	SMOKE	COX GRAND SD LOUNGE
M1-41	PHOTO	SMOKE	COX GRAND SD LOUNGE
M1-42	PHOTO	SMOKE	COX GRAND SD LOUNGE
M1-43	PHOTO	SMOKE	COX GRAND SD LOUNGE
M1-44	PHOTO	SMOKE	COX GRAND SD LOUNGE
M1-45	IAM	SMOKE	COX GRAND SD LOUNGE
M1-46	IAM	SMOKE	COX GRAND SD LOUNGE
M1-47	PHOTO	SMOKE	COX GRAND SD LOUNGE
M1-48	PHOTO	SMOKE	COX GRAND SD LOUNGE
M1-49	PHOTO	SMOKE	COX GRAND SD LOUNGE
M1-50	PHOTO	SMOKE	COX GRAND SD LOUNGE
M1-51	PHOTO	SMOKE	COX GRAND SD LOUNGE
M1-52	PHOTO	SMOKE	COX GRAND SD LOUNGE
M1-53	PHOTO	SMOKE	COX GRAND SD LOUNGE
M1-54	PHOTO	SMOKE	COX GRAND SD LOUNGE
M1-55	PHOTO	SMOKE	COX GRAND SD LOUNGE
M1-56	PHOTO	SMOKE	COX GRAND SD LOUNGE
M1-57	PHOTO	SMOKE	COX GRAND SD LOUNGE
M1-58	IAM	SMOKE	COX GRAND SD LOUNGE
M1-59	IAM	SMOKE	COX GRAND SD LOUNGE
M1-60	IAM	SMOKE	COX GRAND SD LOUNGE
M1-61	IAM	SMOKE	COX GRAND SD LOUNGE
M1-62	IAM	SMOKE	COX GRAND SD LOUNGE
M1-63	IAM	SMOKE	COX GRAND SD LOUNGE
M1-64	IAM	SMOKE	COX GRAND SD LOUNGE
M1-65	IAM	SMOKE	COX GRAND SD LOUNGE
M1-66	IAM	SMOKE	COX GRAND SD LOUNGE
M1-67	IAM	SMOKE	COX GRAND SD LOUNGE
M1-68	IAM	SMOKE	COX GRAND SD LOUNGE
M1-69	IAM	SMOKE	COX GRAND SD LOUNGE
M1-70	IAM	SMOKE	COX GRAND SD LOUNGE
M1-71	IAM	SMOKE	COX GRAND SD LOUNGE
M1-72	IAM	SMOKE	COX GRAND SD LOUNGE
M1-73	IAM	SMOKE	COX GRAND SD LOUNGE
M1-74	IAM	SMOKE	COX GRAND SD LOUNGE
M1-75	IAM	SMOKE	COX GRAND SD LOUNGE
M1-76	IAM	SMOKE	COX GRAND SD LOUNGE
M1-77	IAM	SMOKE	COX GRAND SD LOUNGE
M1-78	IAM	SMOKE	COX GRAND SD LOUNGE
M1-79	IAM	SMOKE	COX GRAND SD LOUNGE
M1-80	IAM	SMOKE	COX GRAND SD LOUNGE
M1-81	IAM	SMOKE	COX GRAND SD LOUNGE
M1-82	IAM	SMOKE	COX GRAND SD LOUNGE
M1-83	IAM	SMOKE	COX GRAND SD LOUNGE
M1-84	IAM	SMOKE	COX GRAND SD LOUNGE
M1-85	IAM	SMOKE	COX GRAND SD LOUNGE
M1-86	IAM	SMOKE	COX GRAND SD LOUNGE
M1-87	IAM	SMOKE	COX GRAND SD LOUNGE
M1-88	IAM	SMOKE	COX GRAND SD LOUNGE
M1-89	IAM	SMOKE	COX GRAND SD LOUNGE
M1-90	IAM	SMOKE	COX GRAND SD LOUNGE
M1-91	IAM	SMOKE	COX GRAND SD LOUNGE
M1-92	IAM	SMOKE	COX GRAND SD LOUNGE
M1-93	IAM	SMOKE	COX GRAND SD LOUNGE
M1-94	IAM	SMOKE	COX GRAND SD LOUNGE
M1-95	IAM	SMOKE	COX GRAND SD LOUNGE
M1-96	IAM	SMOKE	COX GRAND SD LOUNGE
M1-97	IAM	SMOKE	COX GRAND SD LOUNGE
M1-98	IAM	SMOKE	COX GRAND SD LOUNGE
M1-99	IAM	SMOKE	COX GRAND SD LOUNGE
M1-100	IAM	SMOKE	COX GRAND SD LOUNGE
M1-101	IAM	SMOKE	COX GRAND SD LOUNGE
M1-102	IAM	SMOKE	COX GRAND SD LOUNGE
M1-103	IAM	SMOKE	COX GRAND SD LOUNGE
M1-104	IAM	SMOKE	COX GRAND SD LOUNGE
M1-105	IAM	SMOKE	COX GRAND SD LOUNGE
M1-106	IAM	SMOKE	COX GRAND SD LOUNGE
M1-107	IAM	SMOKE	COX GRAND SD LOUNGE
M1-108	IAM	SMOKE	COX GRAND SD LOUNGE
M1-109	IAM	SMOKE	COX GRAND SD LOUNGE
M1-110	IAM	SMOKE	COX GRAND SD LOUNGE
M1-111	IAM	SMOKE	COX GRAND SD LOUNGE
M1-112	IAM	SMOKE	COX GRAND SD LOUNGE
M1-113	IAM	SMOKE	COX GRAND SD LOUNGE
M1-114	IAM	SMOKE	COX GRAND SD LOUNGE
M1-115	IAM	SMOKE	COX GRAND SD LOUNGE
M1-116	IAM	SMOKE	COX GRAND SD LOUNGE
M1-117	IAM	SMOKE	COX GRAND SD LOUNGE
M1-118	IAM	SMOKE	COX GRAND SD LOUNGE
M1-119	IAM	SMOKE	COX GRAND SD LOUNGE
M1-120	IAM	SMOKE	COX GRAND SD LOUNGE
M1-121	IAM	SMOKE	COX GRAND SD LOUNGE
M1-122	IAM	SMOKE	COX GRAND SD LOUNGE
M1-123	IAM	SMOKE	COX GRAND SD LOUNGE
M1-124	IAM	SMOKE	COX GRAND SD LOUNGE
M1-125	IAM	SMOKE	COX GRAND SD LOUNGE
M1-126	IAM	SMOKE	COX GRAND SD LOUNGE
M1-127	IAM	SMOKE	COX GRAND SD LOUNGE
M1-128	IAM	SMOKE	COX GRAND SD LOUNGE
M1-129	IAM	SMOKE	COX GRAND SD LOUNGE
M1-130	IAM	SMOKE	COX GRAND SD LOUNGE
M1-131	IAM	SMOKE	COX GRAND SD LOUNGE
M1-132	IAM	SMOKE	COX GRAND SD LOUNGE
M1-133	IAM	SMOKE	COX GRAND SD LOUNGE
M1-134	IAM	SMOKE	COX GRAND SD LOUNGE
M1-135	IAM	SMOKE	COX GRAND SD LOUNGE
M1-136	IAM	SMOKE	COX GRAND SD LOUNGE
M1-137	IAM	SMOKE	COX GRAND SD LOUNGE
M1-138	IAM	SMOKE	COX GRAND SD LOUNGE
M1-139	IAM	SMOKE	COX GRAND SD LOUNGE
M1-140	IAM	SMOKE	COX GRAND SD LOUNGE
M1-141	IAM	SMOKE	COX GRAND SD LOUNGE
M1-142	IAM	SMOKE	COX GRAND SD LOUNGE
M1-143	IAM	SMOKE	COX GRAND SD LOUNGE
M1-144	IAM	SMOKE	COX GRAND SD LOUNGE
M1-145	IAM	SMOKE	COX GRAND SD LOUNGE
M1-146	IAM	SMOKE	COX GRAND SD LOUNGE
M1-147	IAM	SMOKE	COX GRAND SD LOUNGE
M1-148	IAM	SMOKE	COX GRAND SD LOUNGE
M1-149	IAM	SMOKE	COX GRAND SD LOUNGE
M1-150	IAM	SMOKE	COX GRAND SD LOUNGE
M1-151	IAM	SMOKE	COX GRAND SD LOUNGE
M1-152	IAM	SMOKE	COX GRAND SD LOUNGE
M1-153	IAM	SMOKE	COX GRAND SD LOUNGE
M1-154	IAM	SMOKE	COX GRAND SD LOUNGE
M1-155	IAM	SMOKE	COX GRAND SD LOUNGE
M1-156	IAM	SMOKE	COX GRAND SD LOUNGE
M1-157	IAM	SMOKE	COX GRAND SD LOUNGE
M1-158	IAM	SMOKE	COX GRAND SD LOUNGE
M1-159	IAM	SMOKE	COX GRAND SD LOUNGE
M1-160	IAM	SMOKE	COX GRAND SD LOUNGE
M1-161	IAM	SMOKE	COX GRAND SD LOUNGE
M1-162	IAM	SMOKE	COX GRAND SD LOUNGE
M1-163	IAM	SMOKE	COX GRAND SD LOUNGE
M1-164	IAM	SMOKE	COX GRAND SD LOUNGE
M1-165	IAM	SMOKE	COX GRAND SD LOUNGE
M1-166	IAM	SMOKE	COX GRAND SD LOUNGE
M1-167	IAM	SMOKE	COX GRAND SD LOUNGE
M1-168	IAM	SMOKE	COX GRAND SD LOUNGE
M1-169	IAM	SMOKE	COX GRAND SD LOUNGE
M1-170	IAM	SMOKE	COX GRAND SD LOUNGE
M1-171	IAM	SMOKE	COX GRAND SD LOUNGE
M1-172	IAM	SMOKE	COX GRAND SD LOUNGE
M1-173	IAM	SMOKE	COX GRAND SD LOUNGE
M1-174	IAM	SMOKE	COX GRAND SD LOUNGE
M1-175	IAM	SMOKE	COX GRAND SD LOUNGE
M1-176	IAM	SMOKE	COX GRAND SD LOUNGE
M1-177	IAM	SMOKE	COX GRAND SD LOUNGE
M1-178	IAM	SMOKE	COX GRAND SD LOUNGE
M1-179	IAM	SMOKE	COX GRAND SD LOUNGE
M1-180	IAM	SMOKE	COX GRAND SD LOUNGE
M1-181	IAM	SMOKE	COX GRAND SD LOUNGE
M1-182	IAM	SMOKE	COX GRAND SD LOUNGE
M1-183	IAM	SMOKE	COX GRAND SD LOUNGE
M1-184	IAM	SMOKE	COX GRAND SD LOUNGE
M1-185	IAM	SMOKE	COX GRAND SD LOUNGE
M1-186	IAM	SMOKE	COX GRAND SD LOUNGE
M1-187	IAM	SMOKE	COX GRAND SD LOUNGE
M1-188	IAM	SMOKE	COX GRAND SD LOUNGE
M1-189	IAM	SMOKE	COX GRAND SD LOUNGE
M1-190	IAM	SMOKE	COX GRAND SD LOUNGE
M1-191	IAM	SMOKE	COX GRAND SD LOUNGE
M1-192	IAM	SMOKE	COX GRAND SD LOUNGE
M1-193	IAM	SMOKE	COX GRAND SD LOUNGE
M1-194	IAM	SMOKE	COX GRAND SD LOUNGE
M1-195	IAM	SMOKE	COX GRAND SD LOUNGE
M1-196	IAM	SMOKE	COX GRAND SD LOUNGE
M1-197	IAM	SMOKE	COX GRAND SD LOUNGE
M1-198	IAM	SMOKE	COX GRAND SD LOUNGE
M1-199	IAM	SMOKE	COX GRAND SD LOUNGE
M1-200	IAM	SMOKE	COX GRAND SD LOUNGE

NOTE: THE LABELS SHOWN ABOVE WILL BE USED FOR PROGRAMMING PURPOSES. THE LABELS SHOWN ABOVE WILL BE USED FOR PROGRAMMING PURPOSES. ANY CHANGES TO THESE LABELS MUST BE NOTED ON THE SUBMITTAL REVIEW, PRIOR TO PROGRAMMING.

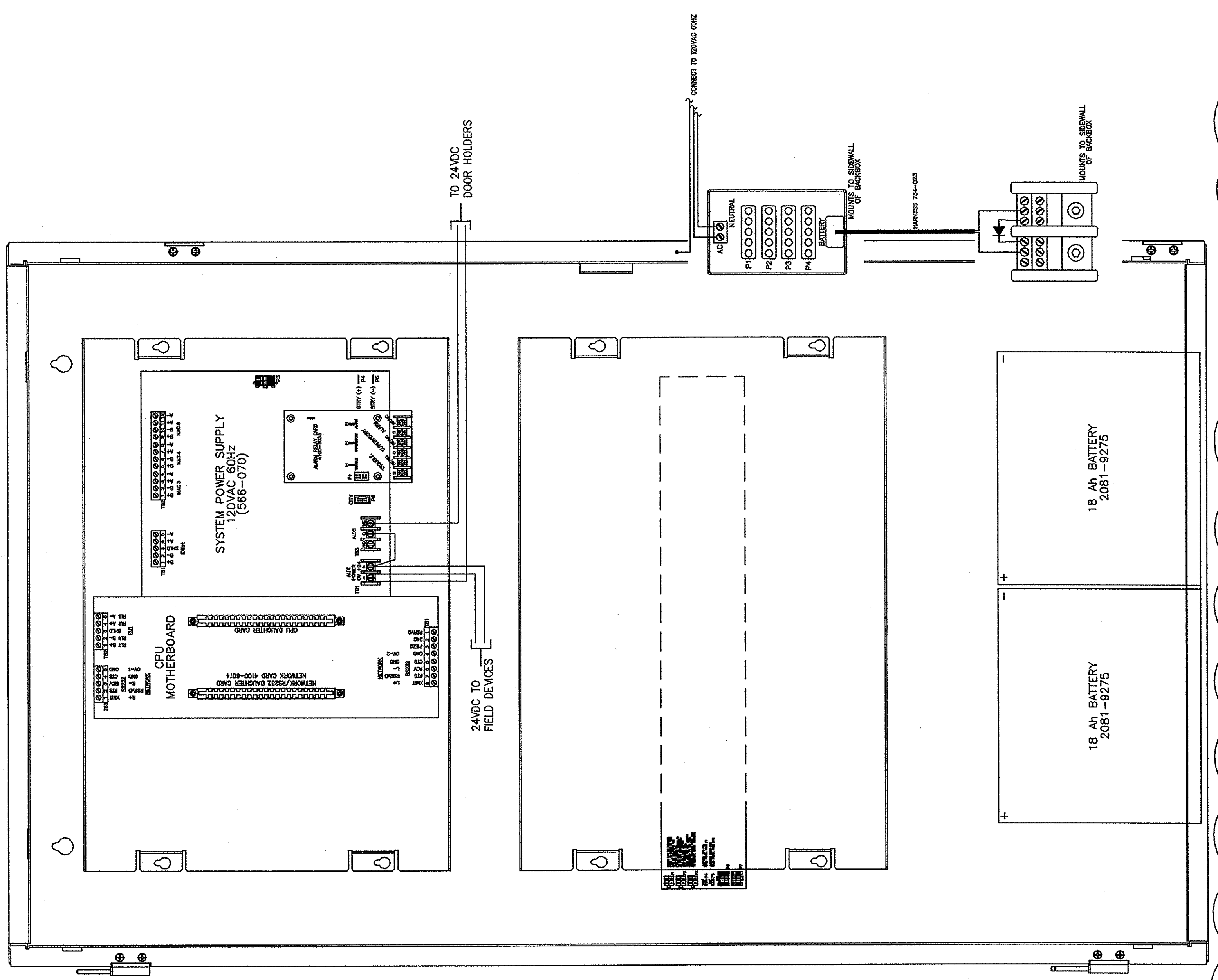

VOLTAGE DROP CALCULATIONS - N3

WIRE GAUGE	STARTING VOLTAGE (AT END OF BATTERY DISCHARGE CYCLE)	MINIMUM DEVICE VOLTAGE	PERCENTAGE VOLTAGE DROP
14 AWG	20.4 VDC	16 VDC	21%
16 AWG	20.4 VDC	16 VDC	21%

VOLTAGE DROP CALCULATIONS - N4

WIRE GAUGE	STARTING VOLTAGE (AT END OF BATTERY DISCHARGE CYCLE)	MINIMUM DEVICE VOLTAGE	PERCENTAGE VOLTAGE DROP
14 AWG	20.4 VDC	16 VDC	21%
16 AWG	20.4 VDC	16 VDC	21%

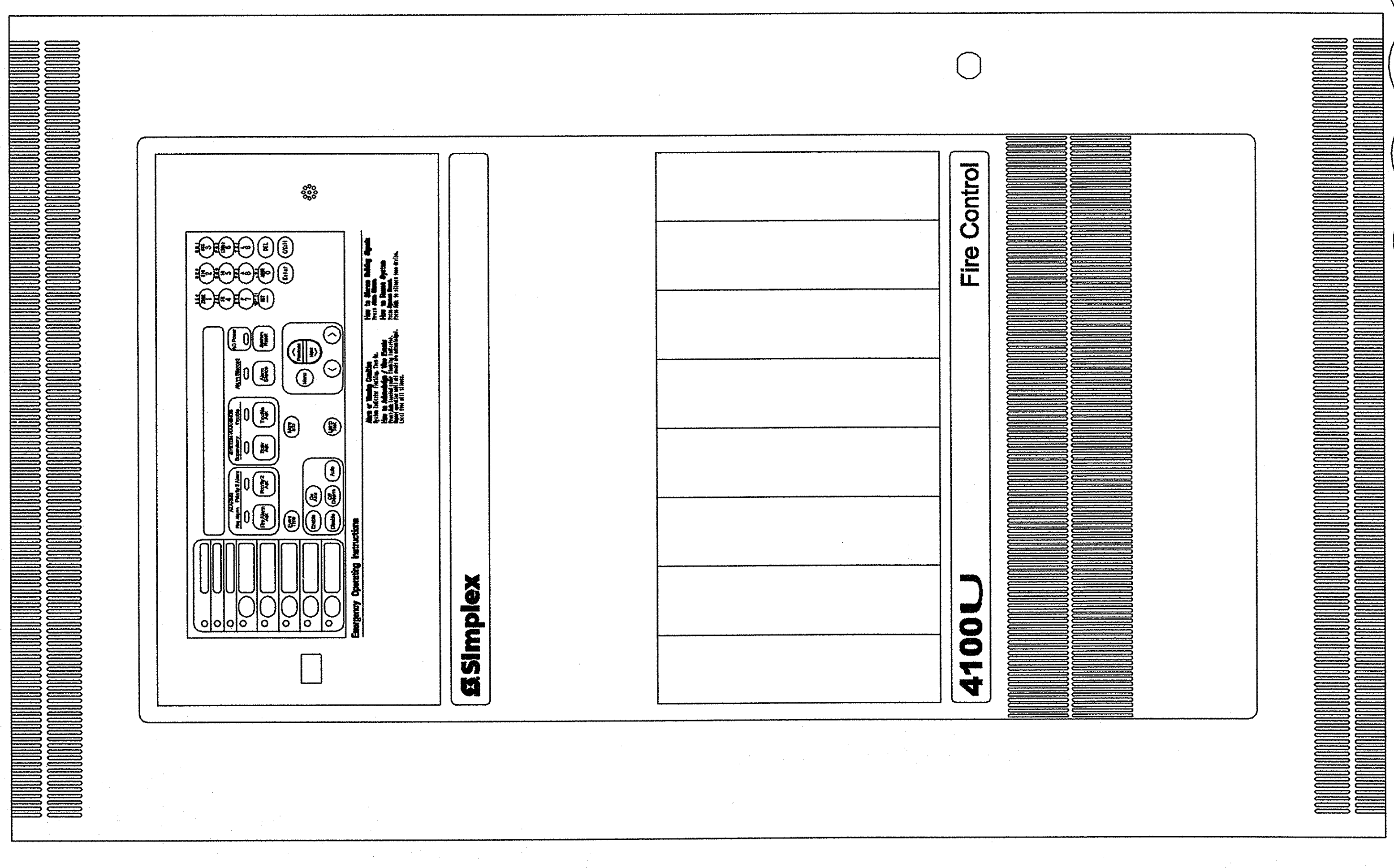

4100U BATTERY CALCULATIONS

Panel Element	Models	Description	Qty	Steady Current	Total Steady	Alarm Current	Total Alarm	Power Source
4100-3111	4100-3111	4100U FIRE ALARM CONTROL PANEL	1	0.373	0.373	0.470	0.470	SPS-1
4100-6014	4100-6014	NETWORK INTERFACE CARD - MODULAR	1	0.046	0.046	0.046	0.046	SPS-1
4100-6056	4100-6056	NETWORK MEDIA CARD - WIRED	1	0.055	0.055	0.055	0.055	SPS-1
4100-6052	4100-6052	SERIAL DACT	1	0.030	0.030	0.040	0.040	SPS-1
Total Panel Steady				0.504	0.504	0.611	0.611	
Peripheral Devices								
4098-9001	4098-9001	IDNET SINGLE ACTION PULL STATION	1	0.000	0.000	0.000	0.000	IDNET
4098-9714	4098-9714	TRIPLE-ARM PHOTO EYE SENSOR	19	0.000	0.000	0.000	0.000	IDNET
4098-9726	4098-9726	TRIPLE-ARM PHOTO EYE SENSOR	19	0.000	0.000	0.000	0.000	IDNET
4098-9843	4098-9843	TRIPLE-ARM PHOTO EYE SENSOR W/ RELAY OUTPUT	1	0.000	0.000	0.000	0.000	SPS-1
4098-9843	4098-9843	ENCAPSULATED RELAY	6	0.000	0.000	0.000	0.000	SPS-1
4098-9843	4098-9843	IDNET RELAY IAM	6	0.000	0.000	0.000	0.000	IDNET
2081-9008	2081-9008	10A RELAY SPDT W/ ENCLOSURE	6	0.000	0.000	0.000	0.000	SPS-1
Notification Appliance Circuits (From NAC Schedule)								
Total Peripheral Steady				0.000	0.000	0.000	0.000	
Total Steady/Alarm				0.504	0.504	0.611	0.611	
Total Steady/Alarm				0.504	0.504	0.611	0.611	

Steady Current: 0.504 A, Alarm Current: 1.413 A

Power Supply SPS-1

Steady Time = 24 Hrs, Standby Ah = 12.096

Alarm Time = 5 Hrs, Alarm Ah = 7.065

Additional Capacity per Manufacturer's Safety Factors = 2.633

Battery Supplied 2081-9275 18AH

Total Ah = 16.268

POWER SUPPLY SUMMARY

POWER ADDRESSABLE ADDR DEVICES	STANDBY ALARM	% OF LOAD CAPACITY
SPS-1	0.007	8%
SPS-1	0.051	8%

- NOTES:
- CONNECT 120 V 60 HZ TO THE AC WIRING BLOCK AS MARKED ON THE WIRING BLOCK. BASE SYSTEM = 2A (MAX).
 - FOR CONNECTION TO AC WIRING BLOCK FROM SYSTEM:

733-948	120 V (BASE SYSTEM)	4009-9201
733-984	220/240 V (BASE SYSTEM)	4009-9301
 - FOR 220/240 VAC 50/60 HZ, CONNECT TO THE AC WIRING BLOCK AS MARKED.
 - CONNECT A 12 AWG COPPER GROUND WIRE FROM SAFETY GROUND IN THE ELECTRICAL DISTRIBUTION PANEL TO THE 4009 SAFETY GROUND STUD.
 - ALL WIRING TO BE TO LOCAL CODE.
 - ALL WIRING EXCEPT SAFETY GROUND IS SUPERVISED.
 - COMPATIBLE BATTERIES:

2081-9272	6.2 AH
2081-9273	12.7 AH
2081-9275	18.0 AH (SEPARATE BOX)

 USE BATTERY HARNESS 733-945. MAXIMUM CHARGER CURRENT IS 1.4 A. BATTERIES ARE 24 VDC.
 - SHADED AREA SHOWS ROUTING LOCATION FOR NOTIFICATION APPLIANCE. WIRING TO THESE APPLIANCES AND BATTERY CONNECTIONS. ALL OTHER WIRING IS POWER LIMITED.
 - MAINTAIN AT LEAST 1/4" SPACING BETWEEN ALL POWER LIMITED WIRING AND NONPOWER LIMITED WIRING.

- PLACE A 10K, 1/2 W (378-030 - BROWN/BLACK/ORANGE) RESISTOR FROM "+-" TO "-" TERMINALS OF UNUSED CIRCUIT(S).
- MAXIMUM CURRENT IS 2.0A EACH CIRCUIT. SEE CHART FOR LINE DISTANCE.
- SUPERVISORY CURRENT IS 1.85 mA/CIRCUIT AT 24 VDC.
- ALARM CURRENT IS 2.0 A AT 24 VDC (EACH CIRCUIT).
- VOLTAGE RATING- NOMINAL 24 VDC, 2 V P-P RIPPLE (MAX.).
- MAXIMUM ALLOWED CURRENT IS 8 A. ALL CURRENT DRAW FROM TB6 (AUXILIARY POWER) AND OPTION CARDS IS TO BE DEDUCTED FROM THE AVAILABLE 8 A.
- TERMINAL DESIGNATIONS "+", "-", AND "-" ARE FOR THE ALARM STATE. WIRE RED TO "+", AND BLACK TO "-".
- NAC WIRING ON 4009-9807 NAC OPTION CARD IS TO BE TERMINATED AS SHOWN HERE FOR THE SYSTEM BOARD. CIRCUIT SPECIFICATIONS ARE AS SHOWN ABOVE, EXCEPT OPTIONAL -9807 NACS ARE RATED 1.5 A MAX. LOAD.
- THE SOFTWARE CONFIGURATION/ADDRESS SWITCH IS LOCATED AT THE TOP EDGE OF THE BOARD. ADDRESSABLE NAC WHEN CONNECTED IN NAC CONTROL MODE, OR ADDRESSABLE NAC WHEN CONNECTED IN IDNet CONTROL MODE. TO SET THE ADDRESS WHEN CONNECTED IN IDNet CONTROL MODE.
- THE SOFTWARE CONFIGURATION/ADDRESS SWITCH IS LOCATED AT THE TOP EDGE OF THE BOARD.
- REFER TO THE INSTALLATION INSTRUCTIONS (574-18) FOR MORE DETAILED INFORMATION ON SWITCH SETTINGS.
- IDNet LINES ARE TO BE 18 AWG TWISTED PAIR. CONSULT YOUR LOCAL BRANCH OFFICE WHEN SHIELD IS NOT DESIRED.
- MAXIMUM ALLOWABLE RUN FROM HOST PANEL TO FARTHEST DEVICE NOT TO EXCEED 2,500 FEET.
- MAXIMUM TOTAL WIRE (INCLUDING ALL T-TAPS) ON CIRCUIT NOT TO EXCEED 10,000 FEET OR .58 UF.
- MAXIMUM QUANTITY OF 4009 TYPE DEVICES PER IDNet CHANNEL IS 5. TOTAL DEVICES ON AN IDNet CHANNEL NOT TO EXCEED 250.
- SHIELD (IF PRESENT) DOES NOT NEED TO BE CONNECTED TO TERMINAL BLOCK WHEN ALTERNATE WIRING METHOD IS USED.
- SWITCH SW1-8 MUST BE OFF FOR IDNet CONTROL.
- WIRING IS SUPERVISED AND POWER LIMITED.
- REFER TO IDNet FIELD WIRING DIAGRAM (842-073) FOR CIRCUIT RATINGS.

SWITCH SETTINGS FOR NAC CONTROL OPERATION:

SWITCH NUMBER	OPERATION (WHEN ON)
1-3	POWER DISTRIBUTION (SEE TABLE)
4	INSERT SYNCHRONIZED STROBE SIGNAL
5	LOCAL GENERATED CODE PATTERN:
ON	ON = MARCH TIME
OFF	OFF = TEMPORAL CODE
6	CONTROL INPUT 2 ON = TRACK INPUT
7	CONTROL INPUT 1 ON = CONTROL CODE PER SWITCH 5
8	OFF = QUICKALERT NAC OPERATION

SWITCH SETTING	POWER DISTRIBUTION
1	3-1 IN (OUT) (NAC)
2	OFF
3	OFF
4	OFF
5	OFF
6	OFF
7	OFF
8	OFF

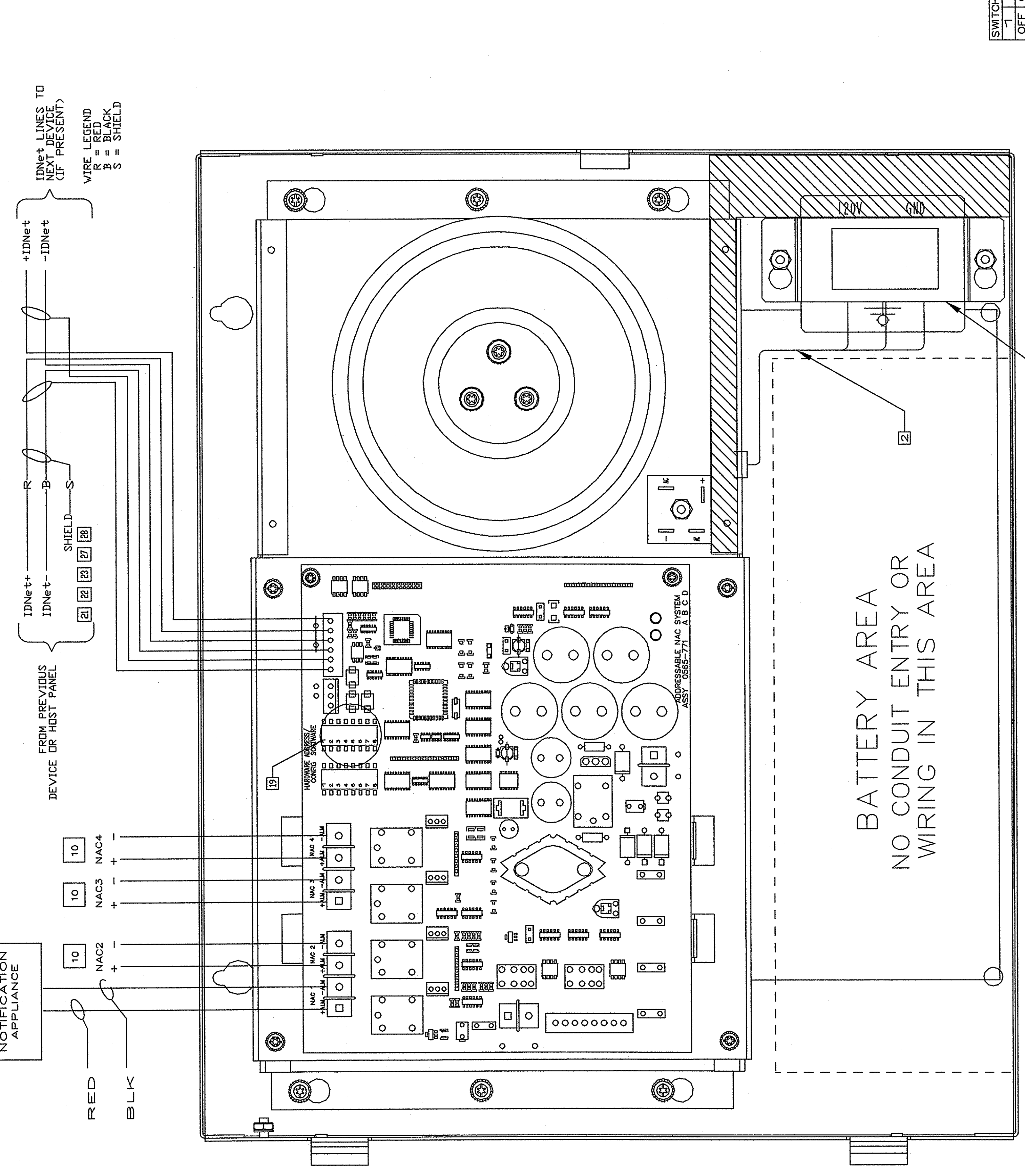
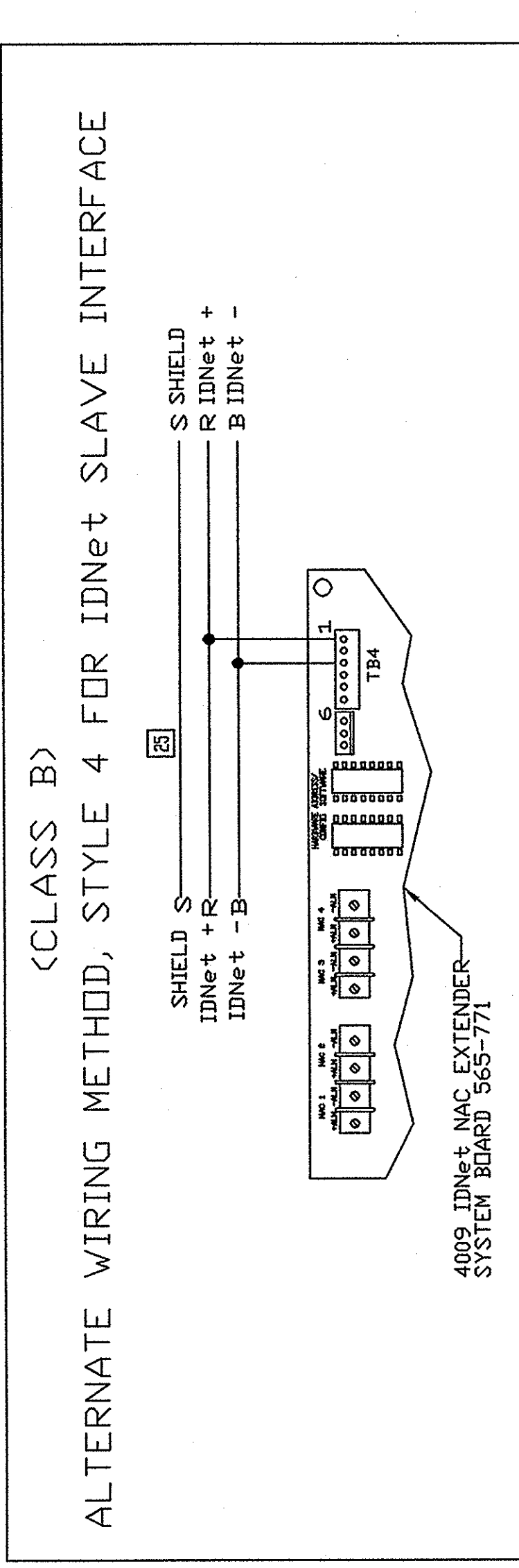

4009 NAC POWER EXTENDER PANEL LAYOUT

NAC-2 BATTERY CALCULATIONS

Module	Description	Qty	Standby Current	Standby Alarm Current	Total Alarm
4009-9201	4009 DINET NAC EXTENDER, 120 VAC	1	0.085	0.085	0.185
Total Panel Sby			0.085		0.185
Total Panel Alarm				0.085	0.185
Total Panel Alarm				0.085	0.185
Total Alarm Amps				0.085	0.185

Control Panel Power (Master Power Supply)
Power For External Peripheral Devices

Standby Time = 24 Hrs
Alarm Time = 5 Mins
Battery Supplied 2081-8272 6.2AH

NAC-2 NOTIFICATION APPLIANCE CIRCUIT SCHEDULE

PLAN CMT	PANEL CIRCUIT	DESCRIPTION	# OF DEVICES	CURRENT (A)
N10	NAC 1	NEW 2ND FLOOR NOTIFICATION	4	0.278
N11	NAC 2	NEW 2ND FLOOR NOTIFICATION	2	0.278
N12	NAC 3	NEW 2ND FLOOR NOTIFICATION	2	0.278
N13	NAC 4	NEW 2ND FLOOR NOTIFICATION	3	0.358

VOLTAGE DROP CALCULATIONS - N10

WIRE GAUGE 14 AWG
2X WIRE RESISTANCE PER FOOT 0.00814 OHMS
STARTING VOLTAGE (AT END OF BATTERY DISCHARGE CYCLE) 20.4 VDC
MINIMUM DEVICE VOLTAGE 16 VDC
PERCENTAGE VOLTAGE DROP 18

DEVICE NUMBER	MODEL	DISTANCE (FT)	DEVICE CURRENT (A)	NAC CURRENT (A)	VOLTAGE DROP (V)	VOLTAGE AT DEVICE (V)
N10-1	4903-3419	10	0.085	0.085	0.07	19.85
N10-2	4903-3417	20	0.085	0.085	0.07	19.85
N10-3	4903-3417	20	0.085	0.085	0.07	19.85
N10-4	4903-3417	20	0.085	0.085	0.07	19.85

VOLTAGE DROP CALCULATIONS - N11

WIRE GAUGE 14 AWG
2X WIRE RESISTANCE PER FOOT 0.00814 OHMS
STARTING VOLTAGE (AT END OF BATTERY DISCHARGE CYCLE) 20.4 VDC
MINIMUM DEVICE VOLTAGE 16 VDC
PERCENTAGE VOLTAGE DROP 18

DEVICE NUMBER	MODEL	DISTANCE (FT)	DEVICE CURRENT (A)	NAC CURRENT (A)	VOLTAGE DROP (V)	VOLTAGE AT DEVICE (V)
N11-1	4903-3419	10	0.085	0.085	0.07	19.85
N11-2	4903-3417	10	0.085	0.085	0.07	19.85

VOLTAGE DROP CALCULATIONS - N12

WIRE GAUGE 14 AWG
2X WIRE RESISTANCE PER FOOT 0.00814 OHMS
STARTING VOLTAGE (AT END OF BATTERY DISCHARGE CYCLE) 20.4 VDC
MINIMUM DEVICE VOLTAGE 16 VDC
PERCENTAGE VOLTAGE DROP 18

DEVICE NUMBER	MODEL	DISTANCE (FT)	DEVICE CURRENT (A)	NAC CURRENT (A)	VOLTAGE DROP (V)	VOLTAGE AT DEVICE (V)
N12-1	4903-3419	10	0.085	0.085	0.07	19.85
N12-2	4903-3417	10	0.085	0.085	0.07	19.85

VOLTAGE DROP CALCULATIONS - N13

WIRE GAUGE 14 AWG
2X WIRE RESISTANCE PER FOOT 0.00814 OHMS
STARTING VOLTAGE (AT END OF BATTERY DISCHARGE CYCLE) 20.4 VDC
MINIMUM DEVICE VOLTAGE 16 VDC
PERCENTAGE VOLTAGE DROP 18

DEVICE NUMBER	MODEL	DISTANCE (FT)	DEVICE CURRENT (A)	NAC CURRENT (A)	VOLTAGE DROP (V)	VOLTAGE AT DEVICE (V)
N13-1	4903-3419	10	0.085	0.085	0.07	19.85
N13-2	4903-3417	10	0.085	0.085	0.07	19.85
N13-3	4903-3417	20	0.085	0.085	0.07	19.85

NAC-1 BATTERY CALCULATIONS

Module	Description	Qty	Standby Current	Standby Alarm Current	Total Alarm
4009-9201	4009 DINET NAC EXTENDER, 120 VAC	1	0.085	0.085	0.185
Total Panel Sby			0.085		0.185
Total Panel Alarm				0.085	0.185
Total Alarm Amps				0.085	0.185

Control Panel Power (Master Power Supply)
Power For External Peripheral Devices

Standby Time = 24 Hrs
Alarm Time = 5 Mins
Battery Supplied 2081-8272 6.2AH

NAC-1 NOTIFICATION APPLIANCE CIRCUIT SCHEDULE

PLAN CMT	PANEL CIRCUIT	DESCRIPTION	# OF DEVICES	CURRENT (A)
N7	NAC 1	NEW 1ST FLOOR NOTIFICATION DEVICES	4	0.421
N8	NAC 2	NEW 1ST FLOOR NOTIFICATION DEVICES	2	0.278
N9	NAC 3	NEW 1ST FLOOR NOTIFICATION DEVICES	2	0.278
N9	NAC 4	NEW 1ST FLOOR NOTIFICATION DEVICES	2	0.278

VOLTAGE DROP CALCULATIONS - N8

WIRE GAUGE 14 AWG
2X WIRE RESISTANCE PER FOOT 0.00814 OHMS
STARTING VOLTAGE (AT END OF BATTERY DISCHARGE CYCLE) 20.4 VDC
MINIMUM DEVICE VOLTAGE 16 VDC
PERCENTAGE VOLTAGE DROP 18

DEVICE NUMBER	MODEL	DISTANCE (FT)	DEVICE CURRENT (A)	NAC CURRENT (A)	VOLTAGE DROP (V)	VOLTAGE AT DEVICE (V)
N8-1	4903-3419	30	0.220	0.220	0.04	20.36
N8-2	4903-3417	30	0.220	0.220	0.04	20.36

VOLTAGE DROP CALCULATIONS - N7

WIRE GAUGE 14 AWG
2X WIRE RESISTANCE PER FOOT 0.00814 OHMS
STARTING VOLTAGE (AT END OF BATTERY DISCHARGE CYCLE) 20.4 VDC
MINIMUM DEVICE VOLTAGE 16 VDC
PERCENTAGE VOLTAGE DROP 18

DEVICE NUMBER	MODEL	DISTANCE (FT)	DEVICE CURRENT (A)	NAC CURRENT (A)	VOLTAGE DROP (V)	VOLTAGE AT DEVICE (V)
N7-1	4903-3419	120	0.175	0.175	0.31	20.09
N7-2	4903-3417	65	0.168	0.168	0.07	19.96
N7-3	4903-3417	65	0.168	0.168	0.07	19.96
N7-4	4903-3417	15	0.083	0.083	0.01	19.96

VOLTAGE DROP CALCULATIONS - N8

WIRE GAUGE 14 AWG
2X WIRE RESISTANCE PER FOOT 0.00814 OHMS
STARTING VOLTAGE (AT END OF BATTERY DISCHARGE CYCLE) 20.4 VDC
MINIMUM DEVICE VOLTAGE 16 VDC
PERCENTAGE VOLTAGE DROP 18

DEVICE NUMBER	MODEL	DISTANCE (FT)	DEVICE CURRENT (A)	NAC CURRENT (A)	VOLTAGE DROP (V)	VOLTAGE AT DEVICE (V)
N8-1	4903-3419	20	0.058	0.058	0.01	20.19
N8-2	4903-3417	20	0.058	0.058	0.01	20.19

VOLTAGE DROP CALCULATIONS - N9

WIRE GAUGE 14 AWG
2X WIRE RESISTANCE PER FOOT 0.00814 OHMS
STARTING VOLTAGE (AT END OF BATTERY DISCHARGE CYCLE) 20.4 VDC
MINIMUM DEVICE VOLTAGE 16 VDC
PERCENTAGE VOLTAGE DROP 18

DEVICE NUMBER	MODEL	DISTANCE (FT)	DEVICE CURRENT (A)	NAC CURRENT (A)	VOLTAGE DROP (V)	VOLTAGE AT DEVICE (V)
N9-1	4903-3419	120	0.220	0.220	0.20	20.20
N9-2	4903-3417	20	0.058	0.058	0.01	20.19

TrueAlert™ NON-ADDRESSABLE SmartSync™ VISIBLE NOTIFICATION APPLIANCES

PRODUCT INFORMATION

FEATURES:

- CLASS B (STYLE V) OPERATION REQUIRES CONNECTION TO SMARTSYNC CONTROL MODULE (SCM) 4000-9030
- CLASS A (STYLE Z) OPERATION IS SUPPORTED BY USING THE 4000-9030 SCM

SPECIFICATIONS:

- HOUSING DIMENSIONS (INCLUDING LENS): 5 1/8" H x 5" W x 2 3/4" D (130 MM x 127 MM x 70 MM)
- TEMPERATURE RANGE: 32° F TO 122° F (0° TO 50° C)
- HUMIDITY RANGE: 10% TO 85% NON-CONDENSING AT 100% F (50% C)
- CONNECTION: TERMINALS FOR #12 AWG TO #14 AWG

STROBE: RATED VOLTAGE RANGE: 18 TO 33 VDC
- FLASH RATE: 1 Hz
- SYNCHRONIZED MAX. LOADING: UP TO 35 SYNCHRONIZED STROBES MAXIMUM PER 1/4"

MODEL NUMBER	COLOR	RATING	18 VDC	24 VDC	30 VDC	33 VDC
4000-9030	WHITE	1500	77 mA	83 mA	88 mA	93 mA
4000-9031	RED	1500	77 mA	83 mA	88 mA	93 mA
4000-9032	WHITE	1500	77 mA	83 mA	88 mA	93 mA
4000-9033	RED	1500	77 mA	83 mA	88 mA	93 mA
4000-9034	WHITE	1500	77 mA	83 mA	88 mA	93 mA
4000-9035	RED	1500	77 mA	83 mA	88 mA	93 mA
4000-9036	WHITE	1500	77 mA	83 mA	88 mA	93 mA
4000-9037	RED	1500	77 mA	83 mA	88 mA	93 mA
4000-9038	WHITE	1500	77 mA	83 mA	88 mA	93 mA
4000-9039	RED	1500	77 mA	83 mA	88 mA	93 mA
4000-9040	WHITE	1500	77 mA	83 mA	88 mA	93 mA
4000-9041	RED	1500	77 mA	83 mA	88 mA	93 mA
4000-9042	WHITE	1500	77 mA	83 mA	88 mA	93 mA
4000-9043	RED	1500	77 mA	83 mA	88 mA <td 93 mA	
4000-9044	WHITE	1500	77 mA	83 mA	88 mA	93 mA

PRODUCT INFORMATION

FEATURES:

- CLASS B (STYLE V) OPERATION REQUIRES CONNECTION TO SMARTSYNC CONTROL MODULE (SCM) 4000-9030
- CLASS A (STYLE Z) OPERATION IS SUPPORTED BY USING THE 4000-9030 SCM

SPECIFICATIONS:

- HOUSING DIMENSIONS (INCLUDING LENS): 5 1/8" H x 5" W x 2 3/4" D (130 MM x 127 MM x 70 MM)
- TEMPERATURE RANGE: 32° F TO 122° F (0° TO 50° C)
- HUMIDITY RANGE: 10% TO 85% NON-CONDENSING AT 100% F (50% C)
- CONNECTION: TERMINALS FOR #12 AWG TO #14 AWG

STROBE: RATED VOLTAGE RANGE: 18 TO 33 VDC
- FLASH RATE: 1 Hz

MODEL NUMBER	COLOR	RATING	18 VDC	24 VDC	30 VDC	33 VDC
4000-9030	WHITE	1500	77 mA	83 mA	88 mA	93 mA
4000-9031	RED	1500	77 mA	83 mA	88 mA	93 mA
4000-9032	WHITE	1500	77 mA	83 mA	88 mA	93 mA
4000-9033	RED	1500	77 mA	83 mA	88 mA	93 mA
4000-9034	WHITE	1500	77 mA	83 mA	88 mA	93 mA
4000-9035	RED	1500	77 mA	83 mA	88 mA	93 mA
4000-9036	WHITE	1500	77 mA	83 mA	88 mA	93 mA
4000-9037	RED	1500	77 mA	83 mA	88 mA	93 mA
4000-9038	WHITE	1500	77 mA	83 mA	88 mA	93 mA
4000-9039	RED	1500	77 mA	83 mA	88 mA	93 mA
4000-9040	WHITE	1500	77 mA	83 mA	88 mA	93 mA
4000-9041	RED	1500	77 mA	83 mA	88 mA	93 mA
4000-9042	WHITE	1500	77 mA	83 mA	88 mA	93 mA
4000-9043	RED	1500	77 mA	83 mA	88 mA	93 mA
4000-9044	WHITE	1500	77 mA	83 mA	88 mA	93 mA

TO ADDITIONAL NOTIFICATION APPLIANCES, THE UNIT MUST BE INSTALLED IN A FLAME RATED ENCLOSURE WITH A 1/2" AIR GAP BETWEEN THE UNIT AND THE ENCLOSURE.

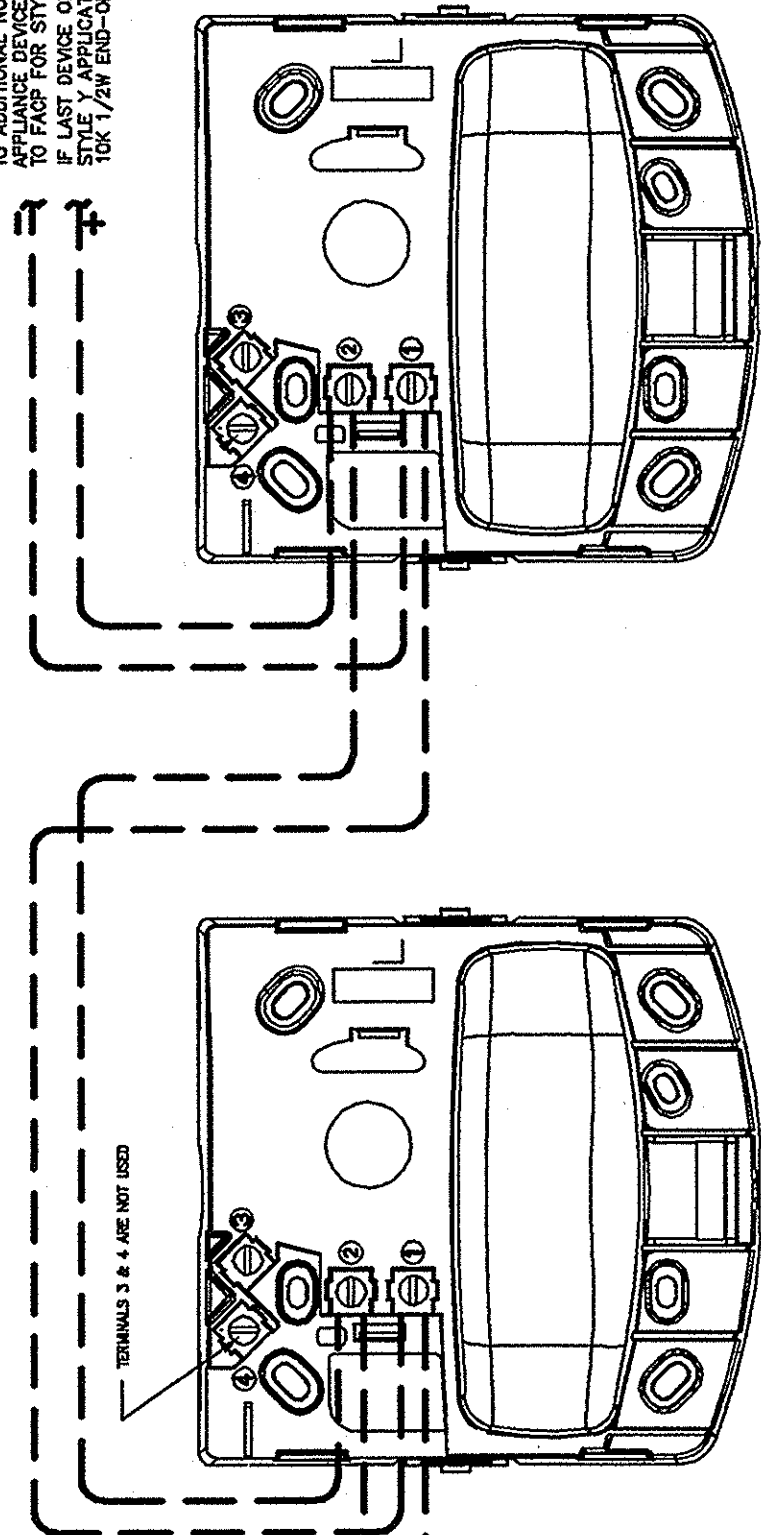

FROM A COMPATIBLE SMARTSYNC CONTROL MODULE (SCM) 4000-9030 OR SMARTSYNC 4000-9034 OR 8002 SYNC CUBE

HORN: RATED VOLTAGE RANGE: 24 TO 29 VDC
- SOUND OUTPUT CHARACTERISTICS: 2400 TO 3700 HZ, SINEWAVE, MODULATED AT 120 HZ RATE

VOLTAGE	15 VDC	24 VDC	33 VDC
SOUND TYPE	STEADY CODED	STEADY CODED	STEADY CODED
REVERBERANT CHAMBER	86 dBA @ 8 ft	88 dBA @ 8 ft	89 dBA @ 8 ft
UL 424 TEST	150 dBA @ 8 ft	150 dBA @ 8 ft	150 dBA @ 8 ft
ANEMOIC CHAMBER	150 dBA @ 8 ft	150 dBA @ 8 ft	150 dBA @ 8 ft

CODED VALUES ARE TYPICAL OF THE OUTPUT MEASURED WITH A TEMPORAL BEARING ON A 'FEAR' SETTING UNDER THE SAME TEST CONDITIONS. CODED HORN OUTPUT PEAK SOUND LEVEL READINGS ARE TYPICALLY 4 dBA HIGHER.

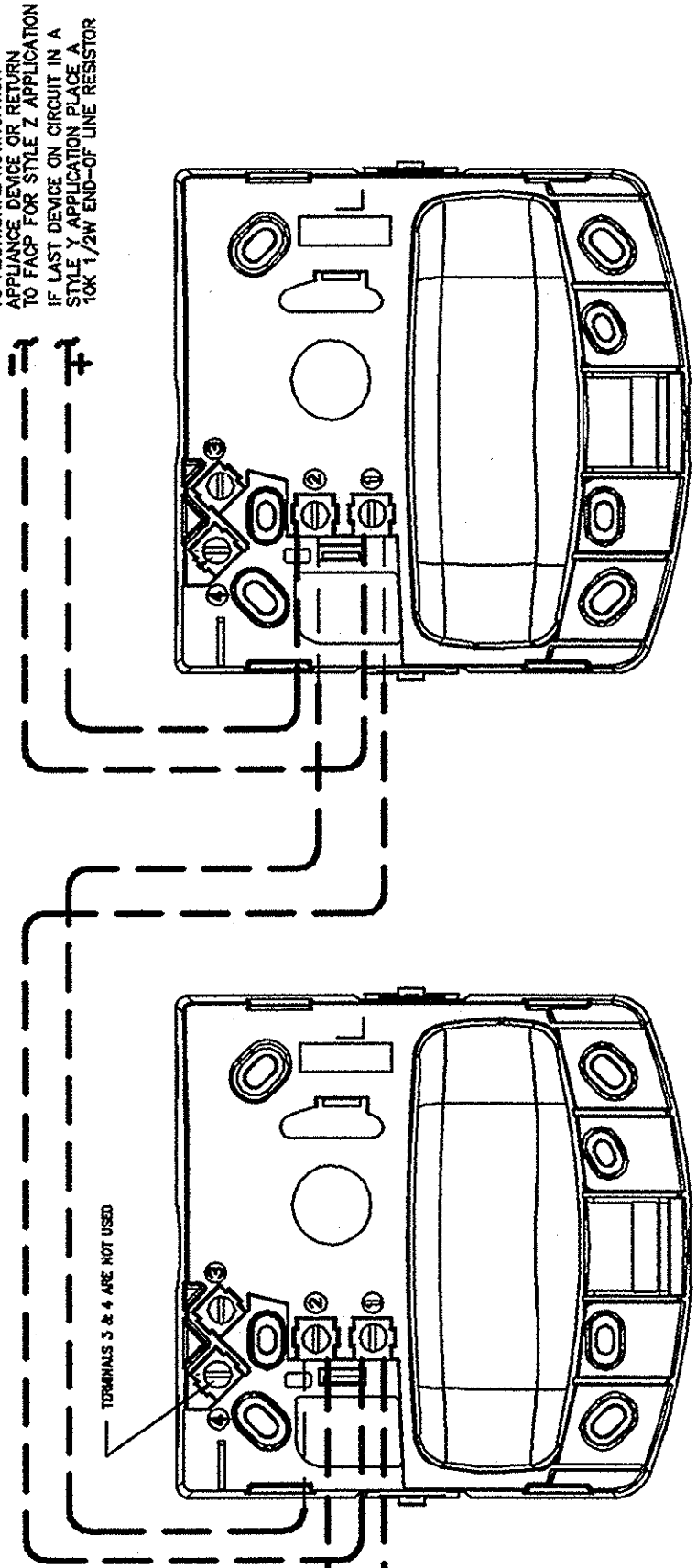

FROM A COMPATIBLE SMARTSYNC CONTROL MODULE (SCM) 4000-9030

TrueAlert™ NON-ADDRESSABLE SmartSync™ AUDIO/VISIBLE NOTIFICATION APPLIANCES

PRODUCT INFORMATION

FEATURES:

- CLASS B (STYLE V) OPERATION REQUIRES CONNECTION TO SMARTSYNC CONTROL MODULE (SCM) 4000-9030
- CLASS A (STYLE Z) OPERATION IS SUPPORTED BY USING THE 4000-9030 SCM

SPECIFICATIONS:

- HOUSING DIMENSIONS (INCLUDING LENS): 5 1/8" H x 5" W x 2 3/4" D (130 MM x 127 MM x 70 MM)
- TEMPERATURE RANGE: 32° F TO 122° F (0° TO 50° C)
- HUMIDITY RANGE: 10% TO 85% NON-CONDENSING AT 100% F (50% C)
- CONNECTION: TERMINALS FOR #12 AWG TO #14 AWG

STROBE: RATED VOLTAGE RANGE: 18 TO 33 VDC
- FLASH RATE: 1 Hz

MODEL NUMBER	COLOR	RATING	18 VDC	24 VDC	30 VDC	33 VDC
4000-9030	WHITE	1500	77 mA	83 mA	88 mA	93 mA
4000-9031	RED	1500	77 mA	83 mA	88 mA	93 mA
4000-9032	WHITE	1500	77 mA	83 mA	88 mA	93 mA
4000-9033	RED	1500	77 mA	83 mA	88 mA	93 mA
4000-9034	WHITE	1500	77 mA	83 mA	88 mA	93 mA
4000-9035	RED	1500	77 mA	83 mA	88 mA	93 mA
4000-9036	WHITE	1500	77 mA	83 mA	88 mA	93 mA
4000-9037	RED	1500	77 mA	83 mA	88 mA	93 mA
4000-9038	WHITE	1500	77 mA	83 mA	88 mA	93 mA
4000-9039	RED	1500	77 mA	83 mA	88 mA	93 mA
4000-9040	WHITE	1500	77 mA	83 mA	88 mA	93 mA
4000-9041	RED	1500	77 mA	83 mA	88 mA	93 mA
4000-9042	WHITE	1500	77 mA	83 mA	88 mA	93 mA
4000-9043	RED	1500	77 mA	83 mA	88 mA	93 mA
4000-9044	WHITE	1500	77 mA	83 mA	88 mA	93 mA

TO ADDITIONAL NOTIFICATION APPLIANCES, THE UNIT MUST BE INSTALLED IN A FLAME RATED ENCLOSURE WITH A 1/2" AIR GAP BETWEEN THE UNIT AND THE ENCLOSURE.

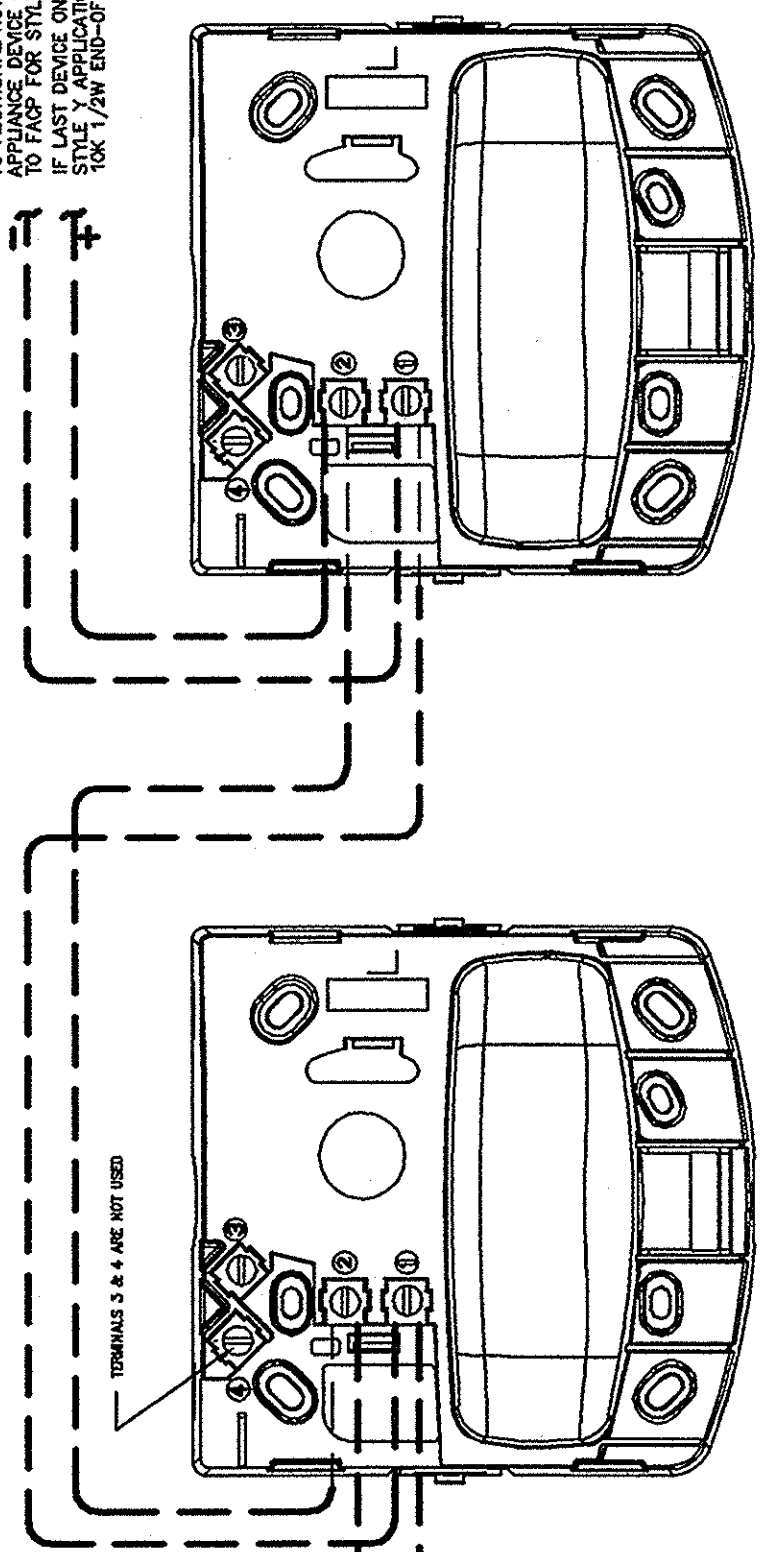

FROM A COMPATIBLE SMARTSYNC CONTROL MODULE (SCM) 4000-9030

FA-11
SHEET 11 OF 11

PROJECT #
42006099
SIS-FATL.DWG

COX HALL
SOUTHERN OREGON UNIVERSITY
ASHLAND, OREGON

SCALE: NONE
WIRING DETAILS
FIRE/LIFE SAFETY SYSTEM

WIRING DETAILS
FIRE/LIFE SAFETY SYSTEM
SCALE: NONE

CHG'D DRN DATE FOR APPROVAL
07/02/02
ISSUE COMMENTS
0

SALES
1-800-848-1788
LAKE OSWEGO, OR 97036
503-675-8521
FAX
503-675-8521

Tyco Fire & Security
SimplexGrinnell

GEXTEX WIRING DIAGRAM

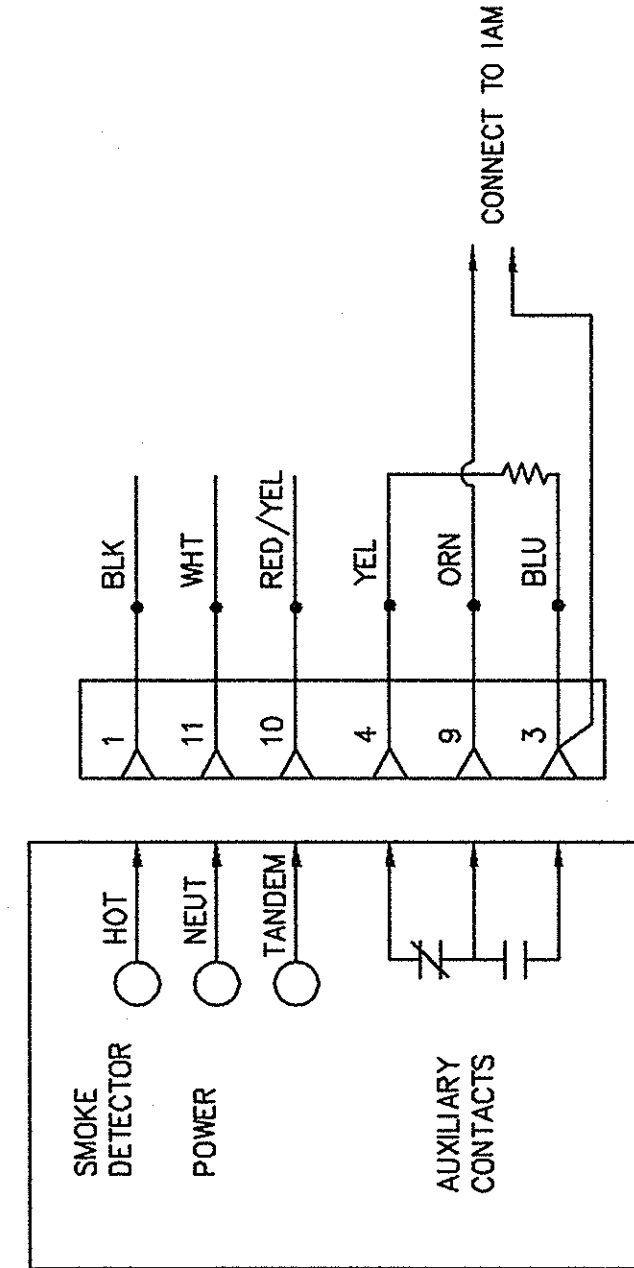
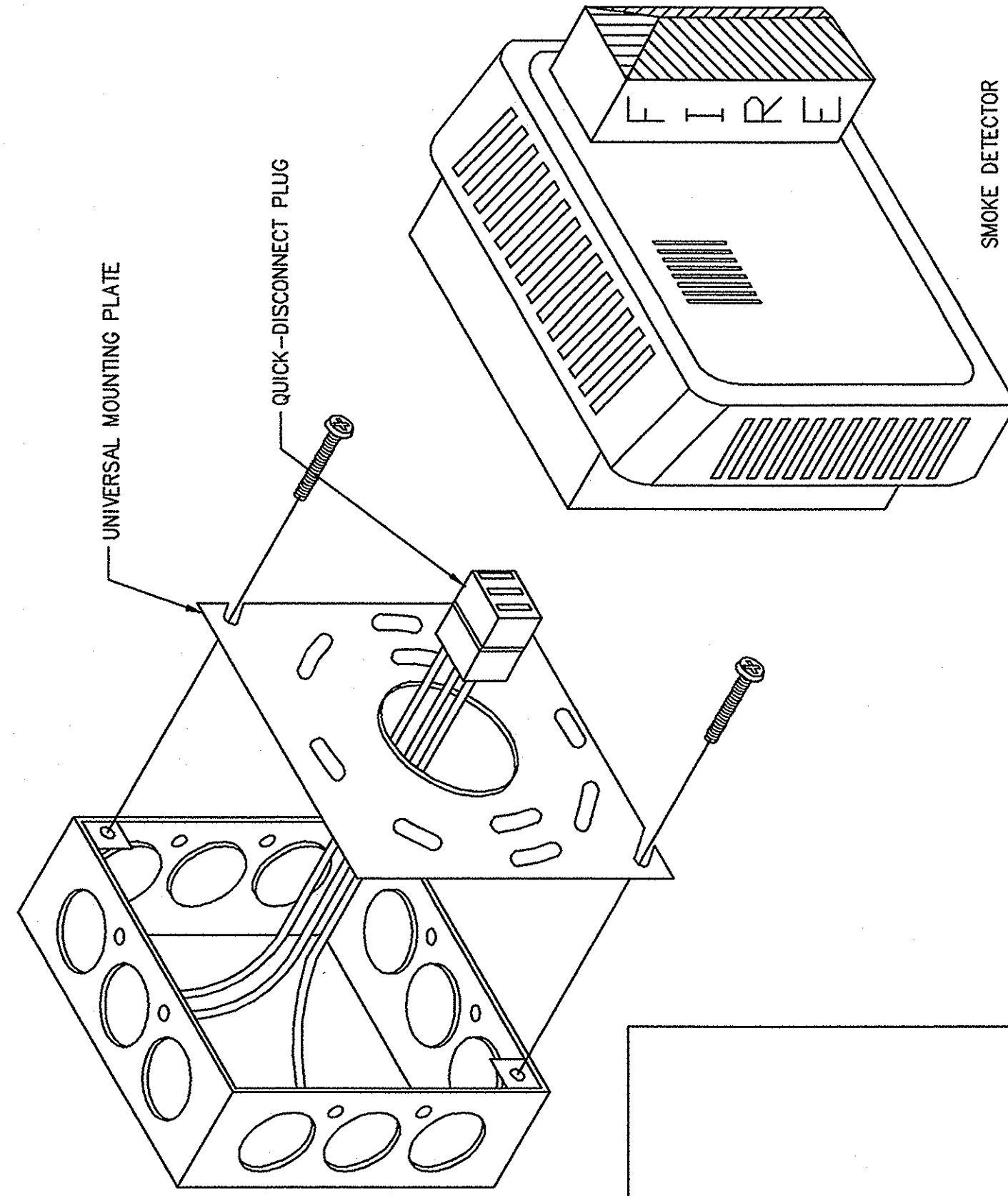

RELAY CONTACTS
RATED LOAD RESISTIVE
0.5 AMP @ 120VAC MAX
OR 1 AMP @ 24 VDC MAX

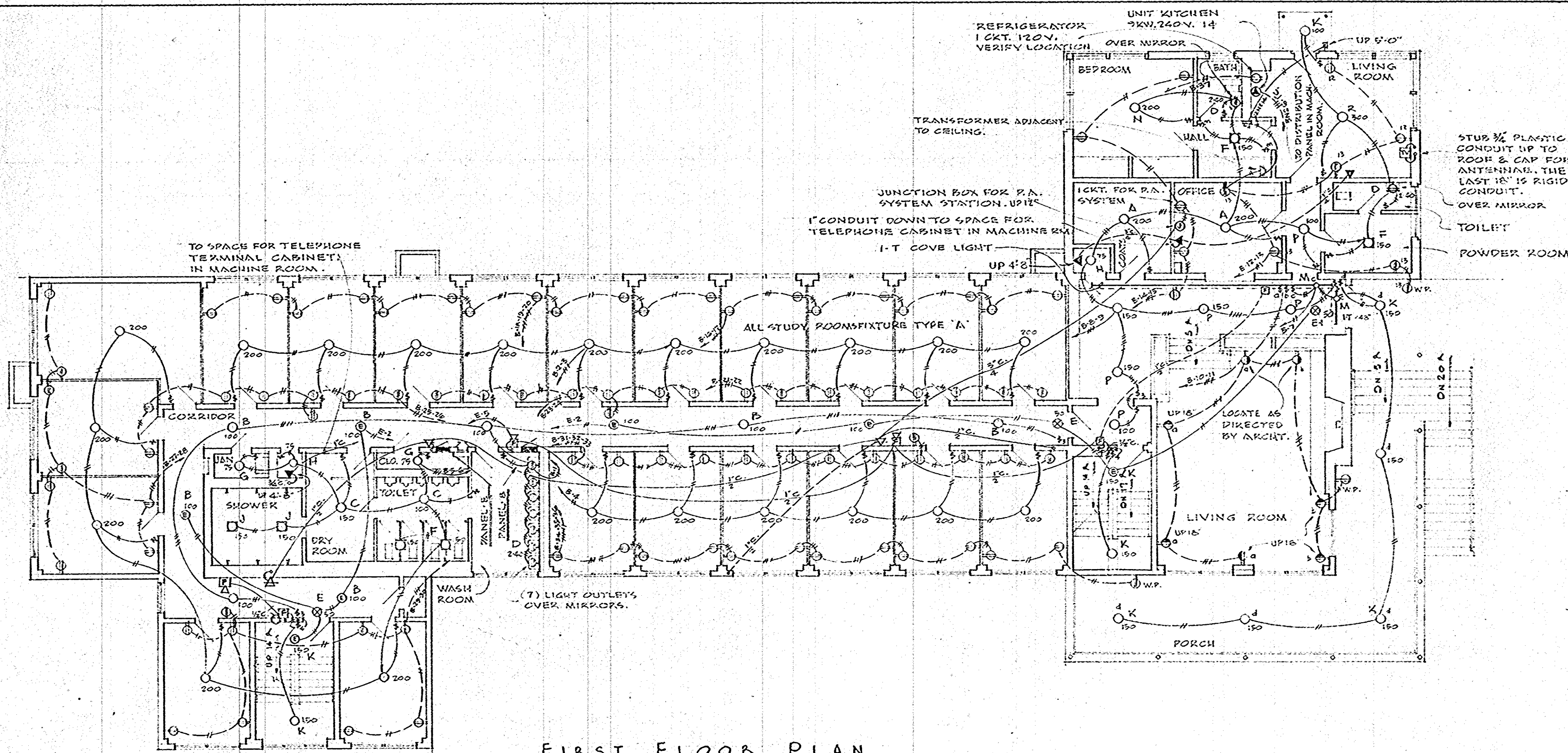

FIRST FLOOR PLAN
SCALE 1/8" = 1'-0"

ELECTRICAL SYMBOLS	
○	CEILING OUTLET
⊙	CEILING OUTLET ON EMERGENCY SYSTEM
◻	CEILING OUTLET RECESSED
○	BRACKET LIGHT
—○—	FLUORESCENT OUTLET IN COVE
⊗	EXIT SIGN OUTLET
○	BRACKET OUTLET WITH PULL CHAIN
⊥	FLOOD OUTLET WALL MOUNTED
⊙	BRACKET LIGHT WITH RECEPTACLE
⊙	DUPLEX CONVENIENCE OUTLET
⊙	SWITCH, RECEPTACLE & PILOT FOR HAND IRON
⊙	DUPLEX CONVENIENCE OUTLET WENTHERPROOF UP 4"
⊙	SPLIT BUS RECEPTACLE
⊙	JUNCTION BOX
⊙	COUPLING & CAP FLUSH WITH FINISHED FLOOR
⊙	SPECIAL PURPOSE OUTLET
⊥	S.P. SWITCH
⊥	3-WAY SWITCH
⊥	4-WAY SWITCH
⊥	SPEAKER OUTLET, WALL
⊥	TIME SWITCH
⊥	TV ANTENNAE OUTLET
⊥	TRANSFORMER FOR DOOR CHIME
⊥	PUSHBUTTON
⊥	DOOR CHIME UP 7'-6"
⊥	FIRE ALARM CALL STATION
⊥	FIRE ALARM HORN
⊥	TELEPHONE OUTLET
○	CONDUIT UP
○	CONDUIT DOWN
○	MOTOR OUTLET
⊥	DISCONNECT SWITCH
⊥	MAGNETIC STARTER
"G1" SAME AS "G" EXCEPT PULL CHAIN	

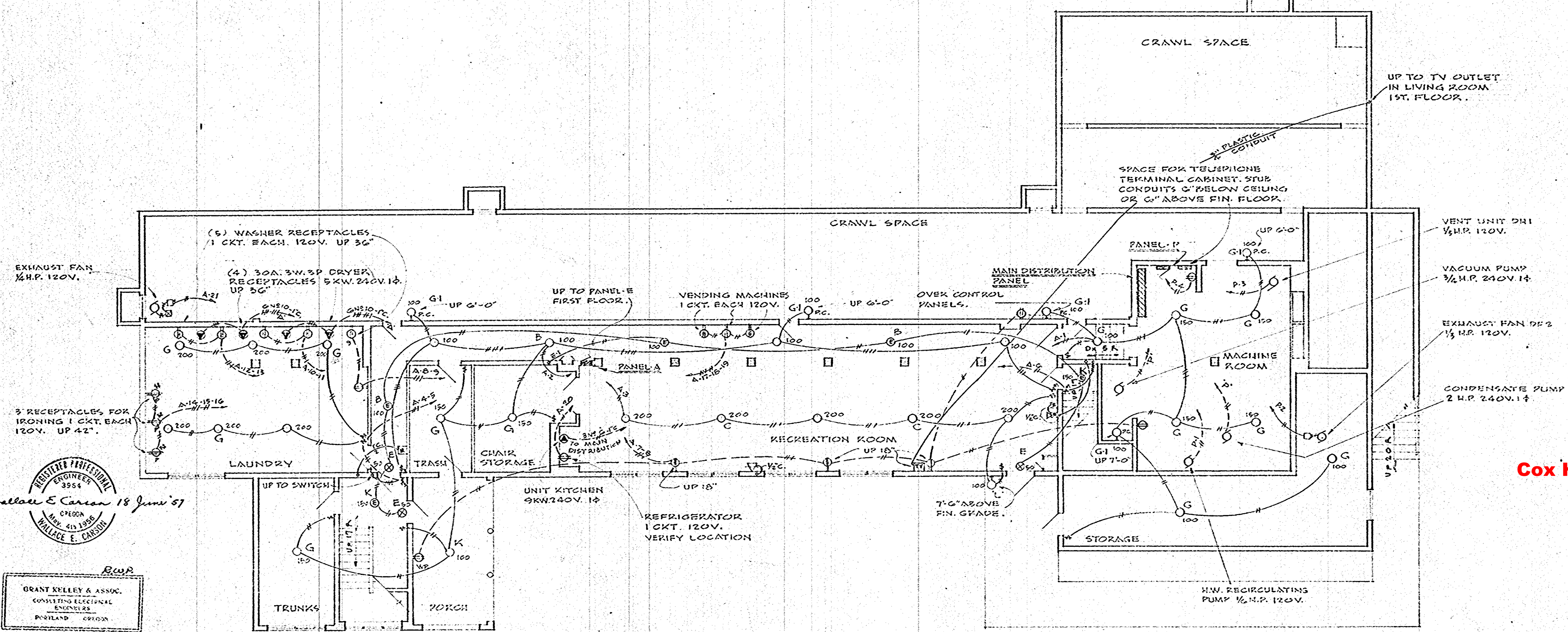

BASEMENT FLOOR PLAN
SCALE 1/8" = 1'-0"

Cox Hall Original Building - 1957

REGISTERED PROFESSIONAL ENGINEER
3954
Wallace E. Carson 18 June 57
OREGON
WALLACE E. CARSON
R.W.P.
GRANT KELLEY & ASSOC.
CONSULTING ELECTRICAL ENGINEERS
PORTLAND OREGON

BASEMENT & FIRST FL. PLANS			
MEN'S DORMITORY FOR SOUTHERN OREGON COLLEGE ASHLAND OREGON			
CHURCH-NEWBERRY-ROEHR & SCHUETTE ARCHITECTS PORTLAND, OREGON			
DRAWN BY	SCALE AS NOTED	JOB NO.	SHEET NO.
CHECKED BY	DATE	D-5612	E-1
DATE	REVISION		

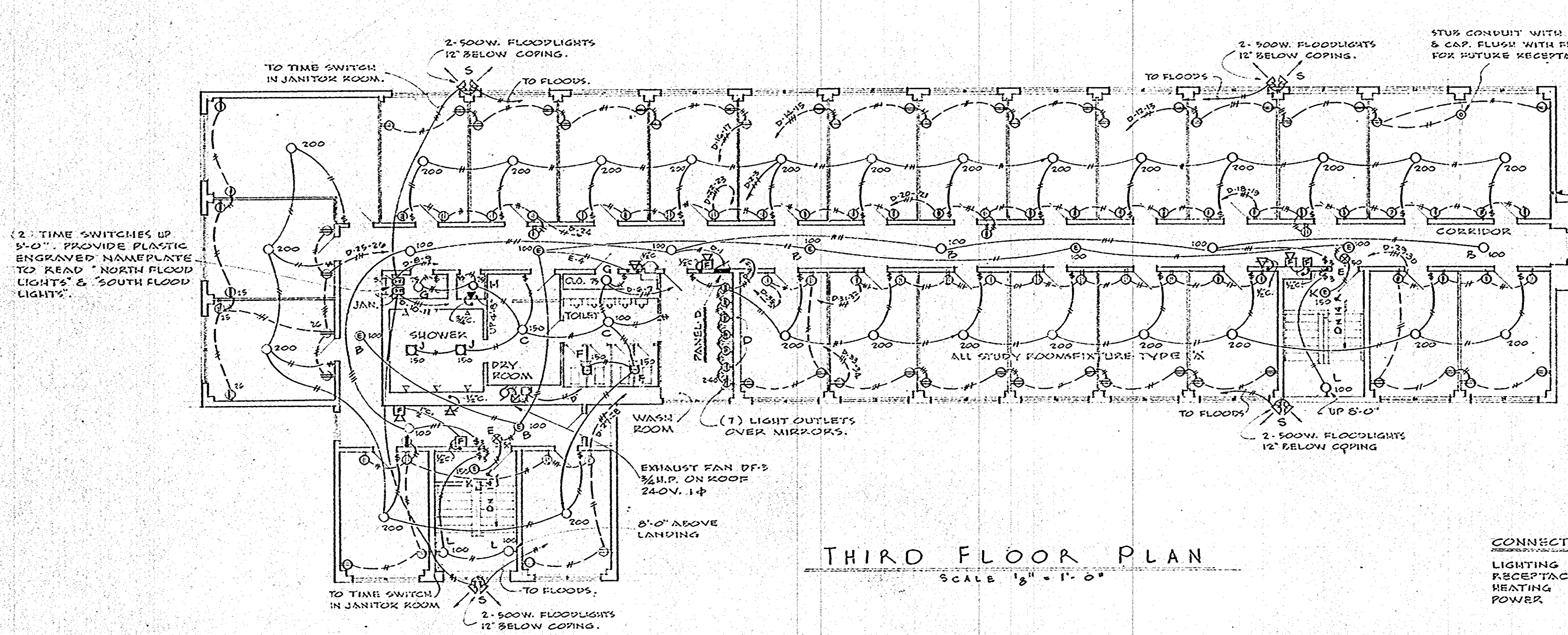

THIRD FLOOR PLAN
SCALE 1/8" = 1'-0"

CONNECTED LOADS
LIGHTING 50 KW
RECEPTACLE 43 KW
HEATING 38 KW
POWER 8.5 KW

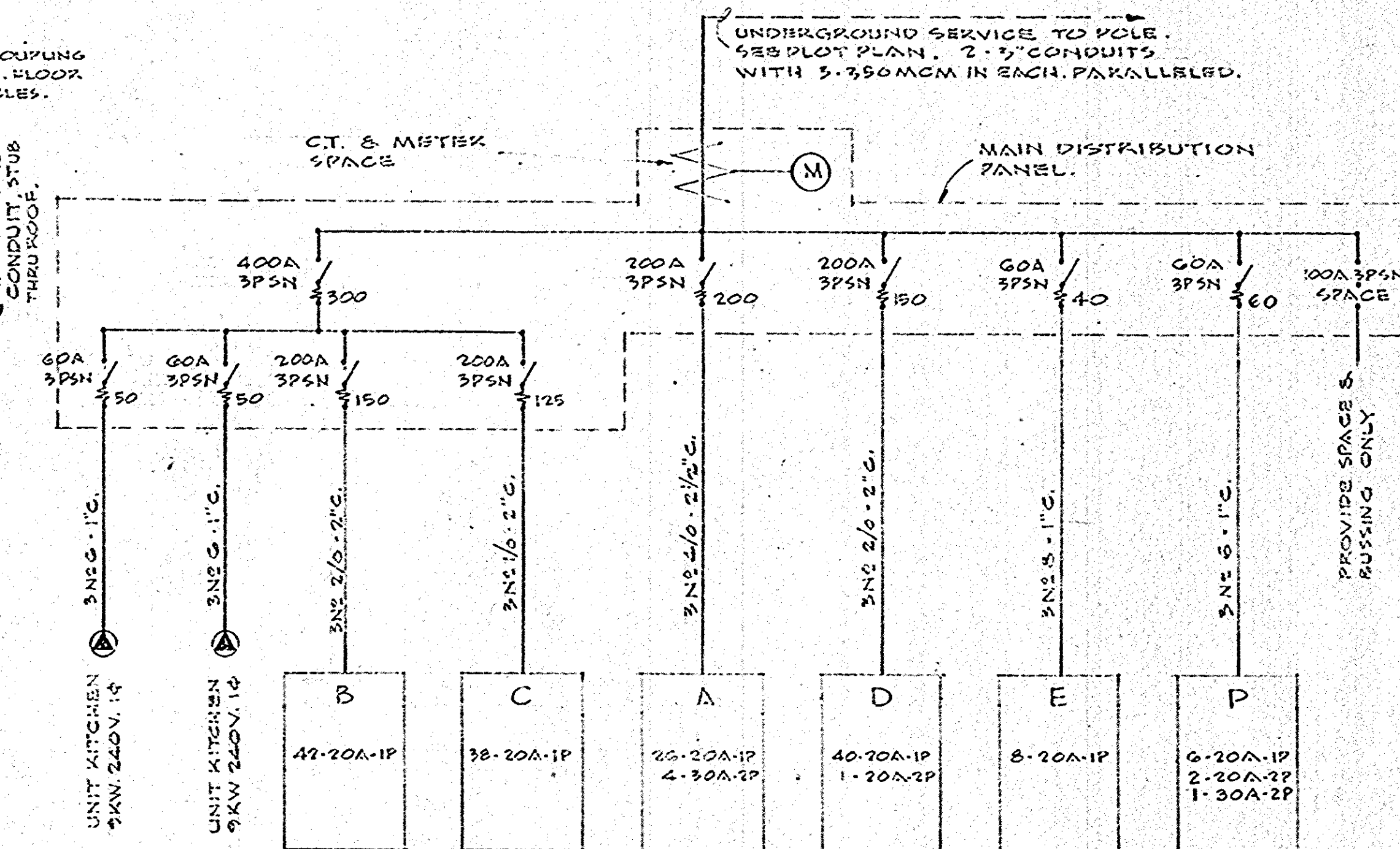

RISER DIAGRAM
120/240V. 1φ 3W.SN
NO SCALE

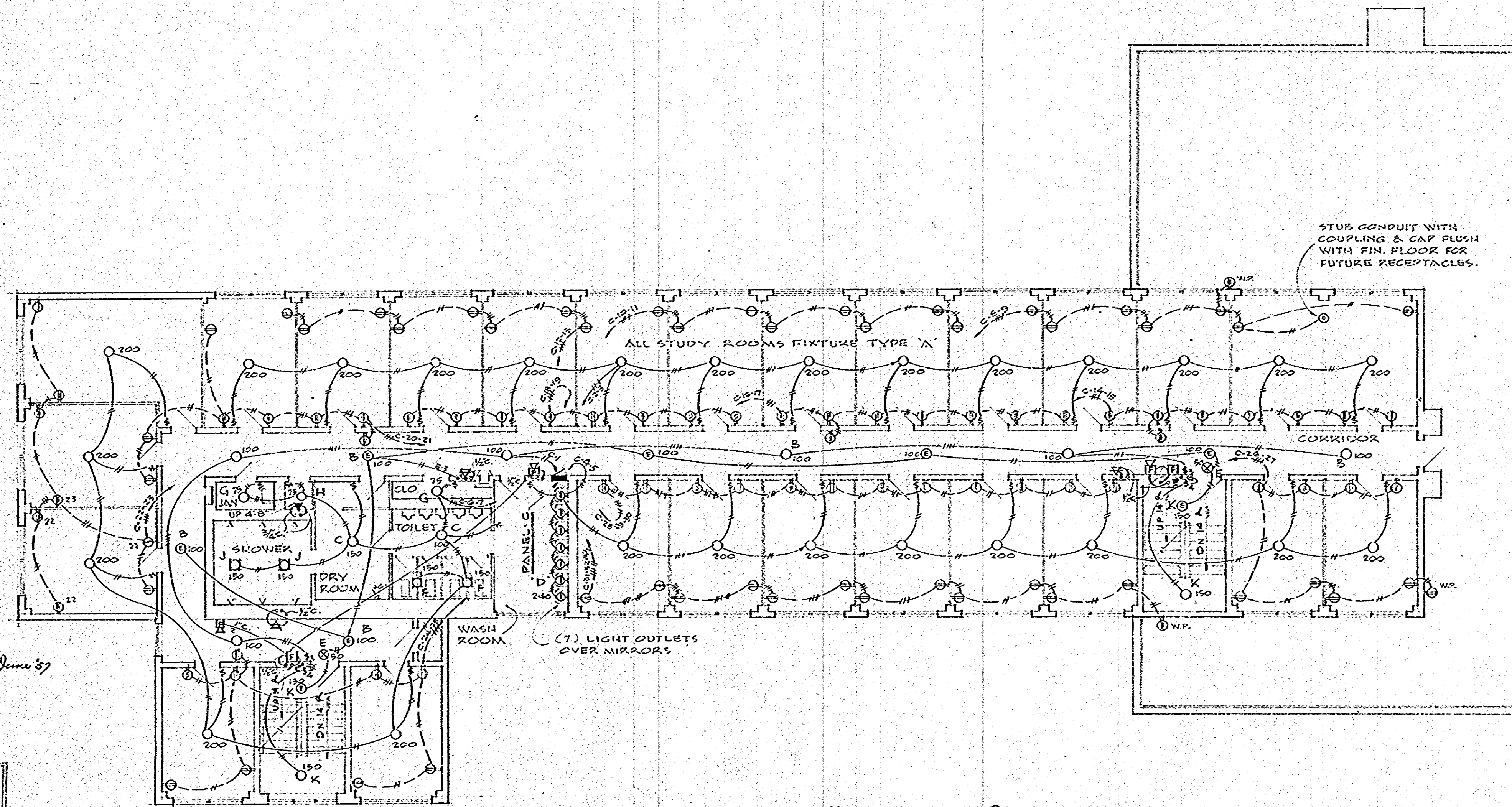

SECOND FLOOR PLAN
SCALE 1/8" = 1'-0"

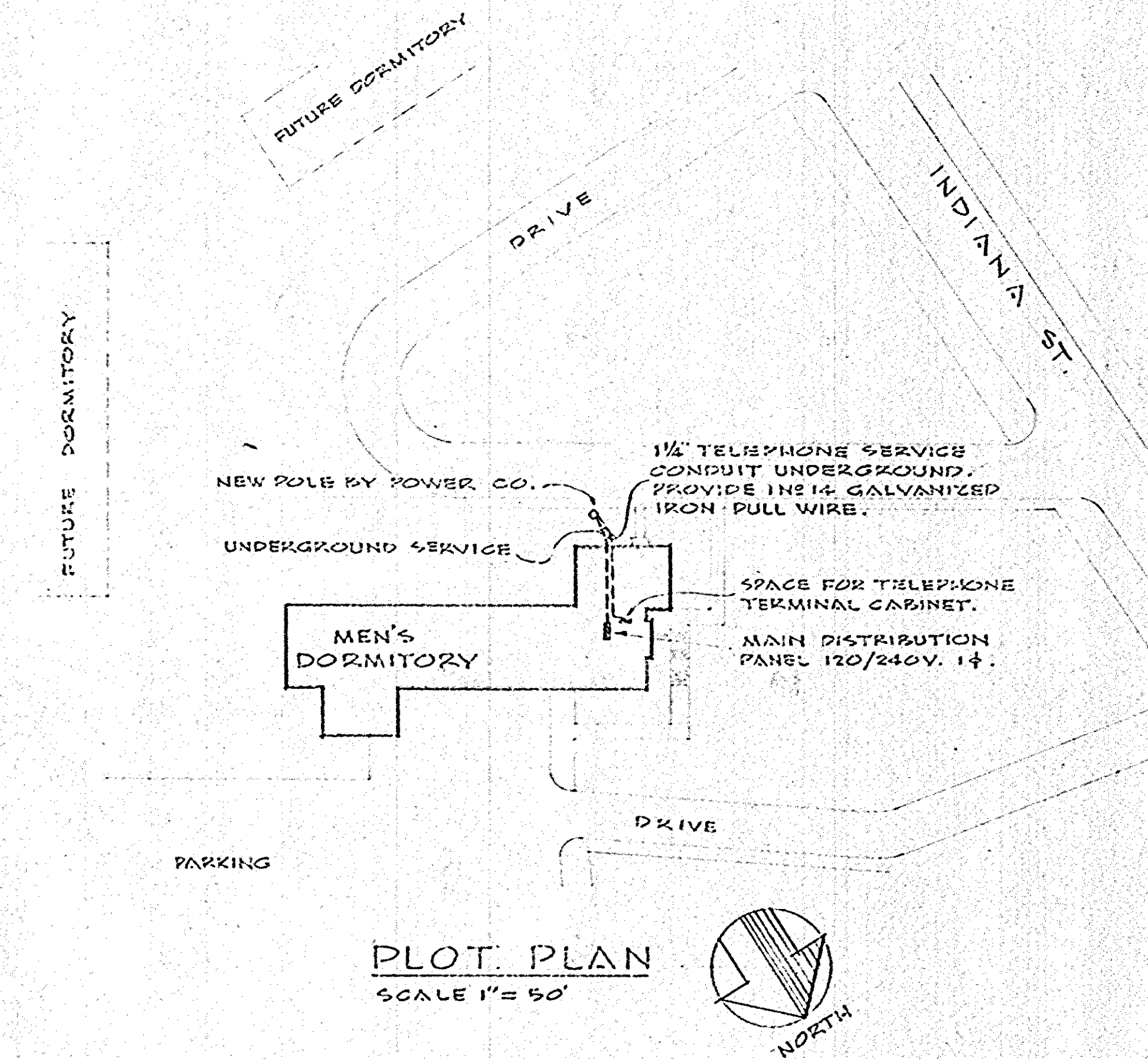

PLOT PLAN
SCALE 1" = 50'

REGISTERED PROFESSIONAL ENGINEER 33964
Waller & Carman 19 June 57
CONSULTING ELECTRICAL ENGINEERS
PORTLAND, OREGON

R.C.P.
GRANT KELLEY & ASSOC.
CONSULTING ELECTRICAL ENGINEERS
PORTLAND, OREGON

Cox Hall Original Building - 1957

SECOND & THIRD FLOOR PLANS			
MEN'S DORMITORY FOR SOUTHERN OREGON COLLEGE ASHLAND, OREGON			
CHURCH-NEWBERRY-ROEHR & SCHUEITE ARCHITECTS PORTLAND, OREGON			
DRAWN BY	SCALE AS NOTED	JOB NO.	SHEET NO.
CHECKED BY	DATE JULY 12, 1957	D-5612	E-2
DATE	REVISION		