

University of Oregon
Gerlinger Annex 350 & 352 Dance Floor Replacement Project

Project Manual

Bid Set
9/5/2012

Owner:
University of Oregon
1295 Franklin Blvd.
Eugene, Oregon 97403
P (541) 346-5276
F (541) 346-6769
Contact: Bruce Budzik
bbbudzik@uoregon.edu

UNIVERSITY OF OREGON

Gerlinger Annex
350 & 352 Dance Floor Replacement

TABLE OF CONTENTS

Bidding & Contracting Requirements

00 0101	Project Title Page
Form B-1	Notice of Retainer Contract Opportunity
Form B-2	Instructions to Bidders
Form B-5	Bid Form
Form B-7	UO Supplemental General Conditions
Form B-8	General Conditions 7/1/12
Form B-9	Performance Bond
Form B-10	Payment Bond
OUS	Retainer Contract Supplement Form
OUS	Retainer Contract Supplement Amendment Form
BOLI	BOLI 01/01/12, as Amended 07/01/12
OUS	MWESB Reporting Form
00 3100	Available Project Information

Project Manual

SPECIFICATIONS

DIVISION 01 -- GENERAL REQUIREMENTS

01 1000	Summary of Work
01 2000	Price and Payment Procedures
01 3000	Administrative Requirements
01 3216	Construction Progress Schedule
01 4000	Quality Requirements
01 5000	Temporary Facilities and Controls
01 6000	Product Requirements
01 6023	Substitution Request Form
01 7000	Execution and Closeout Requirements
01 7419	Construction Waste Management and Disposal
01 7800	Closeout Submittals

(continued...)

UNIVERSITY OF OREGON

Gerlinger Annex
350 & 352 Dance Floor Replacement

DIVISION 06 -- WOOD, PLASTICS, AND COMPOSITES

06 2000 - Finish Carpentry

DIVISION 09 -- FINISHES

09 6470 – Wood Dance Flooring

09 9000 - Painting and Coating

APPENDIX A

STRUCTURAL REPORT

Drawings

TITLE - TITLE SHEET

A001 – SITE / STAGING PLAN, SYMBOLS

A101 - 3RD FLOOR PLAN

A102 – ENLARGED PLANS, DETAILS

A103 - DETAILS

**SECTION 00 0101
PROJECT TITLE PAGE**

PROJECT INFORMATION

PROJECT NAME

University of Oregon Gerlinger Annex Dance Floor Replacement

DATE OF ISSUE

September 5, 2012.

PROJECT OWNER

University of Oregon.

ARCHITECT'S PROJECT NUMBER

1221.00.

PROJECT ADDRESS

Gerlinger Annex

1484 University Street

University of Oregon, Eugene, OR 97403.

PROJECT DESCRIPTION

Installation of approximately 9,000 SF of Sprung Wood Dance Flooring and Vinyl Performance Surface in Rooms 350 and 352 of Gerlinger Annex.

PROJECT CONSULTANTS

Architect:

PIVOT Architecture

44 West Broadway, Suite 300

Eugene, OR 97401.

Phone: 541-342-7291, Fax: 541-342-1535

Principal in Charge: Larry Banks, AIA - lbanks@pivotarchitecture.com

PROCUREMENT TIMETABLE

A. Bid Sets Available: Wednesday, September 5, 2012

B. Mandatory Pre-Bid Conference: Wednesday, September 12, 2012, 2:00pm at Gerlinger Annex, Room 350.

C. Last Day for substitution requests, or requesting additional information, clarifications or questions that have to be answered by Addendum: Friday September 14, 2012, 5:00 pm.

D. Date of Last Addendum Issued: Monday September 17, 2012 at 5:00 pm.

E. Bid Closing Date and Time: Thursday September 20, 2012 at 2:00 p.m.

F. The Owner reserves the right to change the schedule or terminate the entire procurement process at any time.

ARCHITECT'S SEAL AND SIGNATURE



END OF SECTION

OREGON UNIVERSITY SYSTEM

NOTICE OF RETAINER CONTRACT OPPORTUNITY

THIS OPPORTUNITY IS ONLY AVAILABLE TO CONTRACTORS WITH A CURRENT OREGON UNIVERSITY SYSTEM (OUS) RETAINER CONTRACT FOR CONSTRUCTION RELATED SERVICES.

The State of Oregon, acting by and through the State Board of Higher Education on behalf of the University of Oregon (“Owner”) is accepting sealed bids for a public improvement project at the **Capital Construction Main Office** until **2:00pm**, Pacific Time, **September 20, 2012** (“Closing Date and Time”) for the **Gerlinger Annex 350 & 352 Dance Floor Replacement** project located on the campus of the University of Oregon, in Eugene, Oregon (“Project”). The Project includes the installation of new, sprung-style wood dance floors in two dance studios and associated minor demolition and installation of new wood base trim.

A mandatory pre-bid conference will be conducted at Gerlinger Annex 350 on September 12, 2012 at 2:00pm. Bidders shall meet with Owner’s Representative at Gerlinger Annex 350 for that purpose. Attendance will be documented through a sign-in sheet prepared by the Owner’s Representative. Prime bidders who arrive more than 5 minutes after start of time of the meeting (as stated in the solicitation and by the Owner’s Representative’s watch) or after the discussion portion of the meeting (whichever comes first) shall not be permitted to sign in and will not be permitted to submit a bid on the Project.

Bids will be received on a lump-sum basis for all of the work. **Bid packets may be obtained on the OUS Bid and Business Opportunities website (<http://secure.ous.edu/bid/>).**

All bidders must comply with requirements of the prevailing wage law in ORS 279C.800 through ORS 279C.870. All bidders must be registered with the Construction Contractor’s Board at the time of bid submission. No bid will be considered unless fully completed in the manner provided in the “Instructions to Bidders” upon the Bid Form provided and accompanied by Bid Security. OUS encourages bids from Minority, Women, and Emerging Small Businesses.

OREGON STATE BOARD OF HIGHER EDUCATION

By: Jamie Moffitt,
VP of Finance and Administration

OREGON UNIVERSITY SYSTEM
STANDARD RETAINER CONTRACT
INSTRUCTIONS TO BIDDERS

Table of Contents

<u>Article</u>	<u>Title</u>
1.	Definitions
2.	Scope of Work
3.	Examination of Site and Conditions
4.	Substitute Materials Approval Process
5.	Interpretation of Project Manual
6.	Execution of the Bid Form
7.	Prohibition of Alterations to Bid
8.	Submission of Bid
9.	Bid Closing and Opening of Bids
10.	Acceptance or Rejection of Bids by Owner
11.	Withdrawal of Bid
12.	Execution of Contract, Agreement, Performance Bond and Payment Bond
13.	Recyclable Products

INSTRUCTIONS TO BIDDERS

Oregon Administrative Rules (“OAR”) Chapter 580, Divisions 61 and 63 govern this OUS procurement process.

Article 1. Definitions

1.1. Capitalized words used herein but not defined shall have the meaning set forth in the OUS Retainer General Conditions and OAR 580-061-0010. The following terms used herein shall have the meaning set forth below:

“**Bid Form**”- refers to OUS Contract Form B-5 provided by Owner to be completed by Bidder.

“**Project Manual**”- The Project Manual includes, but is not necessarily limited to the following: the Advertisement for Bids or Notice of Contracting Opportunity, these Instructions to Bidders, Supplemental Instructions to Bidders, Bid Form, Bid Bond, OUS Retainer Contract General Conditions, Supplemental General Conditions (if any), Sample Retainer Contract Supplement, Performance Bond, Payment Bond, and the Plans and Specifications.

Article 2. Scope of Work

2.1 The Work contemplated in this document shall be for the Owner in connection with the Project described in the Project Manual.

Article 3. Examination of Site and Conditions

3.1 Before making a Bid, the Bidder shall examine the Work site to ascertain its physical condition. The Bidder shall be responsible for being fully informed as to the quality, quantity and sources of supply of the materials listed on the Project Manual. Failure to comply with this Section will not release Contractor from entering into the Contract nor excuse Contractor from performing the Work in strict accordance with the terms of the Contract Documents.

3.2 The Owner will not be responsible for any loss or unanticipated costs which may arise as a result of Contractor's failure to be fully informed in advance with regard to all conditions pertaining to the Work and the character of the Work required.

3.3. No statement made by any officer, agent, or employee of the Owner in relation to the physical conditions pertaining to the Work site or quality, quantity, and supply of materials will be binding on the Owner, unless included in writing in the Project Manual or an Addendum.

Article 4. Substitute Materials Approval Process

4.1 Prior to submitting a Bid including a Substitution, the Bidder must first seek approval of the Substitution from the Architect (or Engineer, as appropriate hereafter) by submitting a written request for approval at least three calendar days prior to the Closing Date and Time. The Bidder submitting the request shall be responsible for its timely delivery.

4.2 Substitution approval requests shall be accompanied by samples, records of performance, certified copies of tests by impartial and recognized laboratories, and such other information as the Architect may request.

4.3 Within a reasonable time after receiving such a request the Owner (or Architect if so designated) will consider whether the Substitution sought by Bidder is of equal value, utility, as the designated product in the Project Manual.

If the requested Substitution is approved an Addendum to the Project Manual shall be issued. A copy of each Addendum will be posted on the OUS Bid and Business Opportunities website (<http://secure.ous.edu/bid>) and shall become a part of the Project Manual.

4.4 When the Architect approves a Substitution by Addendum, it is with the understanding that the Contractor guarantees the substituted article or material to be equal or better than the one specified.

Article 5. Interpretation of Project Manual

5.1 A Bidder in doubt as to the meaning of any part of the Project Manual may submit a written request for an interpretation to the Architect at any time prior to three calendar days prior to the Closing Date and Time.

5.2 Any interpretation of the Project Manual will be made only by a duly issued Addendum. The Owner will not be responsible for any other explanation or interpretation of the Project Manual nor for any other approval of a particular manufacturer's process or item.

5.3 To establish a basis of quality, certain processes, types of machinery and equipment or kinds of materials may be specified in the Project Manual either by description of process or by designating a manufacturer by name and referring to a brand or product designation or by specifying a kind of material. Whenever a process is designated or a manufacturer named, brand or item designation given, or whenever a process or material covered by patent is designated or described, it shall be understood that the words "or approved equal" follow such name, designation or description, whether they do so or not.

Article 6. Execution of the Bid Form

6.1 The Bid Form relates to Bids on a specific Project Manual. Only the amounts and information asked for on the Bid Form furnished by the Owner will be considered as the Bid. Each Bidder shall Bid upon the Work exactly as set forth in the Bid Form. The Bidder shall include in the Bid a sum to cover the cost of all items contemplated by the Project Manual. Bids that fail to address alternates set forth on the Bid Form may be considered non-responsive.

6.2 Each Bid Form must: 1) Be completed in accordance with these instructions; 2) Include the appropriate signatures as noted on the Bid Form; 3) Include numbers pertaining to base Bids stated both in writing and in figures; and 4) Include the Bidder's typed or clearly printed address.

6.3 When Bidding on an alternate for which there is no charge, the Bidder shall write the words "No Charge" in the space provided on the Bid Form. If one or more alternates is shown on the Bid Form, the Bidder shall indicate whether each is "add" or "deduct."

Article 7. Prohibition of Alterations to Bid

7.1 Bids which are incomplete, or contain ambiguities or conditions not provided for in the Bid Form, may be rejected.

Article 8. Submission of Bid

8.1 Each Bid shall be sealed in an envelope, properly addressed to the appropriate project representative of the Owner, showing on the outside of the envelope the name of the Bidder and the name of the project. Bids will be received at the time and place stated in the Advertisement for Bids.

Article 9. Bid Closing and Opening of Bids

9.1 All Bids must be received by the Owner before the Closing Date and Time. Any Bids received after the Closing Date and Time will be rejected and returned to the Bidder unopened.

~~**9.2** At the time of opening and reading of Bids, each Bid received, irrespective of any irregularities or informalities, will be publicly opened and read aloud.~~

Article 10. Acceptance or Rejection of Bids by Owner

10.1 Unless all Bids are rejected, the Owner will award the Contract based on the lowest responsive Bid from a responsible Bidder. If that Bidder does not execute the Contract, the Contract will be awarded to the next lowest responsible Bidder or Bidders in succession.

10.2 The procedures for Contract awards shall be in compliance with the provisions of OARs adopted by the Owner.

10.3 The Owner reserves the right to reject all Bids and to waive minor informalities.

10.4 [Reserved.]

10.5 In determining the lowest Bidder, the Owner reserves the right to take into consideration any or all authorized base Bids as well as alternates or combinations indicated in the Bid Form.

10.6 If Owner has not accepted a Bid within 30 calendar days after the opening of the Bids, each of the three lowest Bidders may withdraw the Bid submitted.

Article 11. Withdrawal of Bid

11.1 At any time prior to the Closing Date and Time a Bidder may withdraw its Bid. This will not preclude the submission of another Bid by such Bidder prior to the Closing Date and Time.

11.2 After the Closing Date and Time, no Bidder will be permitted to withdraw its Bid within the time period specified in Article 10 for award and execution, except as provided for in that Article.

Article 12. Execution of Contract, Agreement, Performance Bond and Payment Bond

12.1 The Owner will provide the successful Bidder with Contract Documents within 10 calendar days after the award of the Contract. The Bidder shall be required to execute the Contract as provided, including a Performance Bond and a Payment Bond from a surety company licensed to do surety business in the State of Oregon, within 20 calendar days after the award of the Contract. The Contract Documents shall be delivered to the Owner in the manner stated in the Notice of Award.

Article 13. Recyclable Products

13.1 Contractors must use recyclable products to the maximum extent economically feasible in the performance of the Contract.

OREGON UNIVERSITY SYSTEM
STANDARD RETAINER CONTRACT
BID FORM

OUS CAMPUS: ___ University of Oregon _____

PROJECT: ___ Gerlinger Annex 350 & 352 Dance Floor Replacement _____

BID CLOSING DATE: ___ September 20, 2012_ at 2:00pm _____

BID OPENING: ___ N/A_ (no public opening) _____

FROM: _____
Name of Contractor

TO: The State of Oregon, acting by and through the Oregon State Board of Higher Education,
on behalf of the University of Oregon (“Owner”)
(campus or office name and address)

1. The Undersigned *(check one of the following and insert information as requested)*:

___ a. An individual doing business under an assumed name registered under the laws of
the State of _____; or

___ b. A partnership registered under the laws of the State of _____; or

___ c. A corporation organized under the laws of the State of _____; or

___ d. A limited liability corporation/company organized under the laws
of the State of _____;

hereby proposes to furnish all material and labor and perform all Work hereinafter indicated
for the above project in strict accordance with the Contract Documents for the Basic Bid as
follows:

_____ Dollars (\$ _____)

and the Undersigned agrees to be bound by each of the following documents:

- Notice of Retainer Contract Opportunity
- Instructions to Bidders
- Supplemental Instructions to Bidders, if any

- OUS Retainer Contract General Conditions
 - UO Supplemental Retainer Contract General Conditions
 - Sample Retainer Contract Supplement
 - Performance Bond and Payment Bond
 - Plans and Specifications
 - Prevailing Wage Rates
 - Payroll and Certified Statement Form
- (found at http://egov.oregon.gov/BOLI/WHD/PWR/W_PWR_Forms.shtml)

• Any ADDENDA numbered ____ through ____, inclusive (*fill in blanks*).

2. The Undersigned proposes to add to or deduct from the Base Bid indicated above the items of work relating to the following Alternate(s) as designated in the Specifications:

ALTERNATE #1: Not Used.

ADD or DEDUCT: \$ _____

3. The work shall be completed within the time stipulated and specified in Division 1, Section __"Summary of Work" 01 10 00_, of the Specifications.

4. The Undersigned certifies that: (1) This Bid has been arrived at independently and is being submitted without collusion with and without any agreement, understanding, or planned common course of action with any other vendor of materials, supplies, equipment or services described in the invitation to bid designed to limit independent bidding or competition; and (2) The contents of the Bid have not been communicated by the Undersigned or its employees or agents to any person not an employee or agent of the Undersigned and will not be communicated to such person prior to the official opening of the Bid.

5. The undersigned **HAS, HAS NOT** (*circle applicable status*) paid unemployment or income taxes in Oregon within the past 12 months and **HAS, HAS NOT** (*circle applicable status*) a business address in Oregon.

6. The Undersigned agrees, if awarded a contract, to comply with the provisions of ORS 279C.800 through 279C.870 pertaining to the payment of the prevailing rates of wage.

7. Contractor's CCB registration number is _____. As a condition to submitting a bid, a Contractor must be registered with the Oregon Construction Contractors Board in accordance with ORS 701.035 to 701.055, and disclose the registration number. Failure to register and disclose the number will render the bid unresponsive and it will be rejected, unless contrary to federal law.

8. The successful Bidder hereby certifies that all subcontractors who will perform construction work as described in ORS 701.005(2) were registered with the Construction Contractors Board in accordance with ORS 701.035 to 701.055 at the time the subcontractor(s) made a bid to work under the Contract.

9. The successful Bidder hereby certifies that, in compliance with the Worker's Compensation

Law of the State of Oregon, its Worker's Compensation Insurance provider is _____, Policy No. _____, and that Contractor shall submit Certificates of Insurance as required.

10. Contractor's Project Manager for this project is: _____,
Office Phone: _____ Cell Phone: _____.

11. The Undersigned certifies that it has not discriminated against minority, women, or emerging small businesses in obtaining any subcontracts for this project.

12. The Undersigned agrees, if awarded the Contract, to execute and deliver to Owner, within twenty (20) calendar days after receiving the Contract Documents, an Agreement Form and a satisfactory Performance Bond and Payment Bond, each in an amount equal to one hundred (100) percent of the Contract sum, using forms provided by the Owner. The surety requested to issue the Performance Bond and Payment Bond will be:

(name of surety company - not insurance agency)

The Undersigned hereby authorizes said surety company to disclose any information to the Owner concerning the Undersigned's ability to supply a Performance Bond and Payment Bond each in the amount of the Contract.

13. In determining the lowest Bidder, the Owner reserves the right to take into consideration any or all authorized base Bids as well as alternates or combinations indicated in the Bid Form.

14. The Undersigned proposes to use the following Subcontractor to install the sprung wood flooring:

Name: _____.

Address: _____.

Phone: _____.

CCB #: _____.

Contact Name: _____.

Recent Project #1 Name, Contact Name, Contact #, Completion Date:

Recent Project #2 Name, Contact Name, Contact #, Completion Date:

By signature below, Contractor agrees to be bound by this Bid.

NAME OF FIRM	_____
ADDRESS	_____
_____	_____
FEDERAL TAX ID	_____
TELEPHONE NO	_____
FAX NO	_____
SIGNATURE	1) _____
Sole	Individual
or	2) _____
	Partner
or	3) _____
Authorized	Officer of Corporation
(SEAL)	
Attested:	Secretary of Corporation

Payment information will be reported to the IRS under the name and taxpayer ID # provided above. Information not matching IRS records could subject Contractor to 31 percent backup withholding.

******* END OF BID *******

OREGON UNIVERSITY SYSTEM

RETAINER SUPPLEMENTAL GENERAL CONDITIONS

To The

GENERAL CONDITIONS
FOR RETAINER CONTRACTS

Supplement No. _____
Project Name _____

The following modify the July 1, 2012 Oregon University System “General Conditions for Retainer Contracts (“OUS Retainer General Conditions”) for the above referenced Retainer Contract Supplement. Where a portion of the OUS Retainer General Conditions is modified by these Supplemental General Conditions, the unaltered portions shall remain in effect.

Section B.4 is hereby deleted and replaced with the following:

Contractor shall obtain and pay for all necessary permits, licenses and fees, except for those specifically excluded in the Retainer Supplemental General Conditions, for the construction of the Work, for temporary obstructions, enclosures, opening of streets for pipes, walls, utilities, environmental Work, etc., as required for the project. Contractor shall be responsible for all violations of the law, in connection with the construction or caused by obstructing streets, sidewalks or otherwise. Contractor shall give all requisite notices to public authorities. Notwithstanding the first sentence of this paragraph, Owner shall pay for the following: Plan check fees and permit fees required for the general building permit, systems development charges, and building department inspection fees. Notwithstanding the foregoing, however, Contractor shall obtain all permits, licenses and fees required for the construction of the Work.

Section K.2 is hereby deleted and replaced with the following:

As part of the Work, Contractor shall submit two completed operation and maintenance manuals ("O & M Manuals") for review by the Owner prior to submission of any pay request for more than 75% of the Work. Owner’s receipt of the O & M Manuals shall be a condition precedent to any payment thereafter due. The O & M Manuals shall contain a complete set of all submittals, all product data as required by the specifications, training information, telephone list and contact information for all consultants, manufacturers, installer and suppliers, manufacturer's printed data, record and shop drawings, schematic diagrams of systems, appropriate equipment indices, warranties and bonds. The Owner shall review and return one O & M Manual for any modifications or adjustments

required. Prior to submission of its final pay request, Contractor shall deliver two complete and approved sets of O & M Manuals in paper form and one complete and approved set in electronic form to the Owner and Owner's receipt of the O & M Manuals shall be a condition precedent to Owner's obligation to make final payment.

Section K.4 is hereby deleted and replaced with the following:

As part of the Work, and prior to submission of the final application for payment, the Contractor shall schedule with the Owner and provide training sessions for all equipment and systems as required by the Contract Documents. Contractor shall schedule training sessions at least two weeks in advance of the date of training to allow Owner to provide its personnel with adequate notice. The O & M Manual shall be used as a basis for training. In addition to any off-site training required by the Contract Documents, training shall include a formal session conducted at the Work site after the equipment and/or system is completely installed and operational in its normal operating environment.

OREGON UNIVERSITY SYSTEM

GENERAL CONDITIONS FOR RETAINER CONTRACTS

July 1, 2012

INSTRUCTIONS: The attached **Oregon University System General Conditions for Retainer Contracts ("OUS Retainer General Conditions")** apply to all designated retainer contracts. Changes to the OUS Retainer General Conditions (including any additions, deletions or substitutions) should only be made by attaching Retainer Supplemental General Conditions. The text of these OUS Retainer General Conditions should not otherwise be altered.

TABLE OF SECTIONS

SECTION A **GENERAL PROVISIONS**

- A.1 DEFINITION OF TERMS
- A.2 SCOPE OF WORK
- A.3 INTERPRETATION OF CONTRACT DOCUMENTS
- A.4 EXAMINATION OF PLANS, SPECIFICATIONS, AND SITE
- A.5 INDEPENDENT CONTRACTOR STATUS
- A.6 RETIREMENT SYSTEM STATUS AND TAXES
- A.7 GOVERNMENT EMPLOYMENT STATUS

SECTION B **ADMINISTRATION OF THE CONTRACT**

- B.1 OWNER'S ADMINISTRATION OF THE CONTRACT
- B.2 CONTRACTOR'S MEANS AND METHODS
- B.3 MATERIALS AND WORKMANSHIP
- B.4 PERMITS
- B.5 COMPLIANCE WITH GOVERNMENT REGULATIONS
- B.6 SUPERINTENDENCE
- B.7 INSPECTION
- B.8 SEVERABILITY
- B.9 ACCESS TO RECORDS
- B.10 WAIVER
- B.11 SUBCONTRACTS AND ASSIGNMENT
- B.12 SUCCESSORS IN INTEREST
- B.13 OWNER'S RIGHT TO DO WORK
- B.14 OTHER CONTRACTS
- B.15 GOVERNING LAW
- B.16 LITIGATION
- B.17 ALLOWANCES
- B.18 SUBMITTALS, SHOP DRAWINGS, PRODUCT DATA, AND SAMPLES
- B.19 SUBSTITUTIONS
- B.20 USE OF PLANS AND SPECIFICATIONS
- B.21 FUNDS AVAILABLE AND AUTHORIZED
- B.22 NO THIRD PARTY BENEFICIARIES

SECTION C **WAGES AND LABOR**

- C.1 MINIMUM WAGES RATES ON PUBLIC WORKS
- C.2 PAYROLL CERTIFICATION AND FEE REQUIREMENTS, ADDITIONAL RETAINAGE
- C.3 PROMPT PAYMENT AND CONTRACT CONDITIONS
- C.4 PAYMENT FOR MEDICAL CARE
- C.5 HOURS OF LABOR

SECTION D **CHANGES IN THE WORK**

- D.1 CHANGES IN THE WORK
- D.2 DELAYS
- D.3 CLAIMS REVIEW PROCESS

SECTION E
PAYMENTS

- E.1 SCHEDULE OF VALUES
- E.2 APPLICATIONS FOR PAYMENT
- E.3 PAYROLL CERTIFICATION REQUIREMENT
- E.4 DUAL PAYMENT SOURCES
- E.5 RETAINAGE
- E.6 FINAL PAYMENT

SECTION F
JOB SITE CONDITIONS

- F.1 USE OF PREMISES
- F.2 PROTECTION OF WORKERS, PROPERTY, AND THE PUBLIC
- F.3 CUTTING AND PATCHING
- F.4 CLEANING UP
- F.5 ENVIRONMENTAL CONTAMINATION
- F.6 ENVIRONMENTAL CLEAN-UP
- F.7 FORCE MAJEURE

SECTION G
INDEMNITY, BONDING AND INSURANCE

- G.1 RESPONSIBILITY FOR DAMAGES/INDEMNITY
- G.2 PERFORMANCE AND PAYMENT SECURITY, PUBLIC WORKS BOND
- G.3 INSURANCE

SECTION H
SCHEDULE OF WORK

- H.1 CONTRACT PERIOD
- H.2 SCHEDULE
- H.3 PARTIAL OCCUPANCY OR USE

SECTION I
CORRECTION OF WORK

- I.1 CORRECTIONS OF WORK BEFORE FINAL PAYMENT
- I.2 WARRANTY WORK

SECTION J
SUSPENSION AND/OR TERMINATION OF THE WORK

- J.1 OWNER'S RIGHT TO SUSPEND THE WORK
- J.2 CONTRACTOR'S RESPONSIBILITIES
- J.3 COMPENSATION FOR SUSPENSION
- J.4 OWNER'S RIGHT TO TERMINATE CONTRACT
- J.5 TERMINATION FOR CONVENIENCE
- J.6 ACTION UPON TERMINATION

SECTION K
CONTRACT CLOSE-OUT

- K.1 RECORD DOCUMENTS
- K.2 OPERATION AND MAINTENANCE MANUALS
- K.3 COMPLETION NOTICES
- K.4 TRAINING
- K.5 EXTRA MATERIALS
- K.6 ENVIRONMENTAL CLEAN-UP
- K.7 CERTIFICATE OF OCCUPANCY
- K.8 OTHER CONTRACTOR RESPONSIBILITIES
- K.9 SURVIVAL

**OREGON UNIVERSITY SYSTEM
GENERAL CONDITIONS FOR RETAINER CONTRACTS
("OUS Retainer General Conditions")**

**SECTION A
GENERAL PROVISIONS**

A.1 DEFINITION OF TERMS

In the Contract Documents the following terms shall be as defined below:

AMENDMENT, means a writing which, when fully executed by the Parties to this Contract, constitutes a change to a Contract Document. Amendments to Supplements (hereinafter a "Supplement Amendment") shall be issued in accordance with the changes provisions of Section D and, if applicable, establish a Contract Price or Contract Time adjustment.

APPLICABLE LAWS, means federal, state and local laws, codes, rules, regulations and ordinances applicable to the Work and to the Contract.

ARCHITECT/ENGINEER, means the Person appointed by the Owner to make drawings and specifications and, to provide contract administration of the Work contemplated by the Contract to the extent provided herein or by supplemental instruction of Owner (under which Owner may delegate responsibilities to the Architect/Engineer), in accordance with ORS Chapter 671 (Architects) or ORS Chapter 672 (Engineers) and administrative rules adopted thereunder.

CHANGE ORDER, means a written order issued by the Owner to be later included as an Amendment. A Change Order shall not be effective until executed as an Amendment.

CLAIM, means a demand by Contractor pursuant to Section D.3 for review of the denial of Contractor's initial request for an adjustment of Contract terms, payment of money, extension of Contract Time or other relief, submitted in accordance with the requirements and within the time limits established for review of Claims in these OUS Retainer General Conditions.

CONSTRUCTION CHANGE DIRECTIVE, means a written order by the Owner to the Contractor requiring a change in the Work within the general scope of the Contract Documents, issued under the changes provisions of Section D.

CONTRACT, means the written agreement between the Owner and the Contractor comprised of the Contract Documents which describe the Work to be done and the obligations between the parties.

CONTRACT DOCUMENTS, means the Solicitation Document and addenda thereto, Instructions to Offerors, Supplemental Instructions to Offerors, the OUS Retainer Contract, OUS Retainer General Conditions, Retainer Supplemental General Conditions, if any, the accepted Offer, Plans, Specifications, Supplements, Amendments, and Construction Change Directives .

CONTRACT PERIOD, as set forth in the Contract Documents, means the total period of time beginning with the full execution of a Supplement and, if applicable, the issuance of a Notice to Proceed and concluding upon Final Completion.

CONTRACT PRICE, means the total of the awarded Offer amount, as increased or decreased by the price of approved alternates, as indicated in the Contract Documents.

CONTRACT TIME, means any incremental period of time allowed under the Contract to complete any portion of the Work as reflected in the project schedule.

CONTRACTOR, means the Person awarded the Contract for the Work contemplated.

DAYS, are calendar days, including weekdays, weekends and holidays, unless otherwise specified.

DIRECT COSTS, means, unless otherwise provided in the Contract Documents, the cost of materials, including sales tax, cost of delivery; cost of labor, including social security, Medicare and unemployment insurance, and fringe benefits required by agreement or custom; worker's compensation insurance; project specific insurance (including, without limitation, Builder's Risk Insurance and Builder's Risk Installation Floater); bond premiums, rental cost of equipment, and machinery required for execution of the Work; and the additional costs of field personnel directly attributable to the Work.

FINAL COMPLETION, means the final completion of all requirements under the Contract, including Contract Closeout as described in Section K but excluding Warranty Work as described in Section I.2, and the final payment and release of all retainage, if any, released.

FORCE MAJEURE, means an act, event or occurrence caused by fire, riot, war, acts of God, nature, sovereign, or public enemy, strikes, freight embargoes or any other act, event or occurrence that is beyond the control of the party to this Contract who is asserting Force Majeure.

MWESB REPORT, means an accurate report by the Contractor to the Owner identifying all Minority, Women and Emerging Small Business (MWESB) enterprises, as those terms are defined in ORS 200.005, receiving contracts throughout the course of the Work. An initial MWESB report is required (see Section E.2.9) and MWESB Reports are required annually (see Section E.2.9) and as a condition of final payment (see Section K.1). The initial report shall be in the form required by OUS and as posted from time to time on the OUS website and shall include the total number of contracts and subcontracts awarded to MWESB enterprises and the dollar value of their respective contracts and subcontracts. The annual reports shall include the total number of contracts and subcontracts awarded to MWESB enterprises, the dollar value of each, and the expenditure toward each contract and subcontract during the previous twelve (12) months. The final report shall include the total number of contracts and subcontracts awarded to MWESB enterprises and the dollar value of their respective contracts and subcontracts including all Supplements and Amendments incorporated during the course of the project. The reports shall only include enterprises certified with the State of Oregon as MWESB enterprises and shall include individual identification of each enterprise as a Minority business enterprise, a Women business enterprise, and/or an Emerging Small Business Enterprise, as applicable.

NOTICE TO PROCEED, means the official written notice from the Owner stating that the Contractor is to proceed with the Work defined in the Contract Documents. Notwithstanding the Notice to Proceed, Contractor shall not be authorized to proceed with the Work until all initial Contract requirements, including the Contract, performance bond and payment bond, and certificates of insurance, have been fully executed and submitted to Owner in a suitable form.

OFFER, means a bid in connection with Instructions to Bidders or a proposal in connection with a Request for Proposals.

OFFEROR, means a bidder in connection with Instructions to Bidders or a proposer in connection with a Request for Proposals.

OVERHEAD, means those items which may be included in the Contractor's markup (general and administrative expense and profit) and that shall not be charged as Direct Cost of the Work, including without limitation such Overhead expenses as wages or salary of personnel above the level of foreman (i.e., superintendents and project managers), expenses of Contractor's offices and supplies at the job site (e.g. job trailer) and at Contractor's principal place of business and including expenses of personnel staffing the job site office and Contractor's principal place of business, and Commercial General Liability Insurance and Automobile Liability Insurance.

OWNER, means the State of Oregon acting by and through the Oregon State Board of Higher Education, in its own right or on behalf of one of its institutions as identified in the Solicitation Document, also known as the Oregon University System (OUS). Owner may elect, by written notice to Contractor, to delegate certain duties to more than one party, including without limitation, to an Architect/Engineer. However, nothing in these OUS Retainer General Conditions is intended to abrogate the separate design professional responsibilities of Architects under ORS Chapter 671 or of Engineers under ORS Chapter 672.

PERSON, means a natural person or entity doing business as a sole proprietorship, a partnership, a joint venture, a corporation, a limited liability company or partnership, or any other entity possessing the legal capacity to contract.

PLANS, means the drawings which show the location, type, dimensions, and details of the Work to be done under the Contract.

PUNCH LIST, means the list of Work yet to be completed or deficiencies which need to be corrected in order to achieve Final Completion of the Contract.

RECORD DOCUMENT, means the as-built Plans, Specifications, testing and inspection records, product data, samples, manufacturer and distributor/supplier warranties evidencing transfer of ownership to Owner, operational and maintenance manuals, shop drawings, Construction Change Directives, MWESB Reports, correspondence, certificate(s) of occupancy, and other documents listed in Subsection B.9.1 of these OUS Retainer General Conditions, recording all Services performed.

SOLICITATION DOCUMENT, means Instructions to Bidders or Offerors or a Request for Proposal or a Request for Quotes.

SPECIFICATION, means any description of the physical or functional characteristics of the Work, or of the nature of a supply, service or construction item. Specifications may include a description of any requirement for inspecting, testing or preparing a supply, service or construction item for delivery and the quantities or qualities of materials to be furnished under the Contract. Specifications generally will state the results or products to be obtained and may, on occasion, describe the method and manner of doing the Work to be performed. Specifications may be incorporated by reference and/or may be attached to the Contract.

SUBCONTRACTOR, means a Person having a direct contract with the Contractor, or another Subcontractor, to perform one or more items of the Work.

SUBSTANTIAL COMPLETION, means the date when the Owner accepts in writing the construction, alteration or repair of the improvement to real property constituting the Work or any designated portion thereof as having reached that state of completion when it may be used or occupied for its intended purpose. Substantial Completion of facilities with operating systems occurs only after thirty (30) continuous Days of successful, trouble-free operation of the operating systems as provided in Section K.4.2.

SUBSTITUTIONS, means items that in function, performance, reliability, quality, and general configuration are the same or better than the product(s) specified. Approval of any substitute item shall be solely determined by the Owner. The decision of the Owner is final.

SUPPLEMENT, means a writing which, when fully executed by the Parties thereto, constitutes written agreement between the Owner and the Contractor comprised of the Contract Documents which describe the Work to be done and the obligations between the parties.

RETAINER SUPPLEMENTAL GENERAL CONDITIONS, means those conditions that remove from, add to, or modify these OUS Retainer General Conditions. Retainer Supplemental General Conditions may be included in the Solicitation Document or may be a separate attachment to the Contract.

WORK, means the furnishing of all materials, equipment, labor, transportation, services and incidentals necessary to successfully complete any individual item or the entire Contract and the carrying out of duties and obligations imposed by the Contract Documents.

A.2 SCOPE OF WORK

The Work contemplated under this Contract includes all labor, materials, transportation, equipment and services for, and incidental to, the completion of all construction work in connection with the project described in the Contract Documents. The Contractor shall perform all Work necessary so that the project can be legally occupied and fully used for the intended use as set forth in the Contract Documents.

A.3 INTERPRETATION OF CONTRACT DOCUMENTS

A.3.1 Unless otherwise specifically defined in the Contract Documents, words which have well-known technical meanings or construction industry meanings are used in the Contract Documents in accordance with such recognized meanings. Contract Documents are intended to be complementary. Whatever is called for in one, is interpreted to be called for in all. However, in the event of conflicts or discrepancies among the Contract Documents, interpretations will be based on the following descending order of precedence:

- (a) Contract Supplements, Amendments and Construction Change Directives, with those of later date having precedence over those of an earlier date;
- (b) The Retainer Supplemental General Conditions;
- (c) The OUS Retainer Contract;
- (d) The OUS Retainer General Conditions;
- (e) Division One (General Requirements) of the Specifications;
- (f) Detailed Schedules of finishes, equipment and other items included in the Specifications;
- (g) Plans and Specifications (other than Division One and the Detailed Schedules to the Specifications);
- (h) Large-scale drawings on Plans;
- (i) Small-scale drawings on Plans;
- (j) Dimension numbers written on Plans which shall prevail and take precedence over dimensions scaled from Plans;
- (k) The Solicitation Document, and any addenda thereto;
- (l) The accepted Offer.

A.3.2 In the case of an inconsistency between Plans and Specifications or within either document not clarified by addendum, the better quality or greater quantity of Work shall be provided in accordance with the Owner's interpretation in writing.

A.3.3 If the Contractor finds discrepancies in, or omissions from the Contract Documents, or if the Contractor is in doubt as to their meaning, the Contractor shall at once notify the Owner. Matters concerning and interpretation of requirements of the Contract Documents will be decided by the Owner, who may delegate that duty in some instances to the Architect/Engineer. Responses to Contractor's requests for interpretation of Contract Documents will be made in writing by Owner (or the Architect/Engineer) within any time limits agreed upon or otherwise with reasonable promptness. Interpretations and decisions of the Owner (or Architect/Engineer) will be consistent with the intent of and reasonably inferable from the Contract Documents. Contractor shall not proceed without direction in writing from the Owner (or Architect/Engineer).

A.3.4 References to standard specifications, manuals, codes of any technical society, organization or association, to the laws or regulations of any governmental authority, whether such reference be specific or by implication, shall mean the latest standard specification, manual, code, laws or regulations in effect in the jurisdiction where the project is occurring on the first published date of the Solicitation Document, except as may be otherwise specifically stated.

A.4 EXAMINATION OF PLANS, SPECIFICATIONS, AND SITE

A.4.1 It is understood that the Contractor, before submitting an Offer, has made a careful examination of the Contract Documents; has become fully informed as to the quality and quantity of materials and the character of the Work required; and has made a careful examination of the location and conditions of the Work and the sources of supply for materials. The Owner will in no case be responsible for any loss or for any unanticipated costs that may be suffered by the Contractor as a result of the Contractor's failure to acquire full information in advance in regard to all conditions pertaining to the Work. No oral agreement or conversation with any officer, agent, or personnel of the Owner, or with the Architect/Engineer either before or after the execution of this Contract, shall affect or modify any of the terms or obligations herein contained.

A.4.2 Should the Plans or Specifications fail to particularly describe the materials, kind of goods, or details of construction of any aspect of the Work, Contractor shall have the duty to make inquiry of the Owner and Architect/Engineer as to what is required prior to performance of the Work. Absent Specifications to the contrary, the materials or processes that would normally be used to produce first quality finished Work shall be considered a part of the Contract requirements.

A.4.3 Any design errors or omissions noted by the Contractor shall be reported promptly to the Owner, including without limitation, any nonconformity with Applicable Laws.

A.4.4 If the Contractor believes that adjustments to cost or Contract Time is involved because of clarifications or instructions issued by the Owner (or Architect/Engineer) in response to the Contractor's notices or requests for information, the Contractor must submit a written request to the Owner, setting forth the nature and specific extent of the request, including all time and cost impacts against the Contract as soon as possible, but no later than thirty (30) Days after receipt by Contractor of the clarifications or instructions issued. If the Owner denies Contractor's request for additional compensation, additional Contract Time, or other relief that Contractor believes results from the clarifications or instructions, the Contractor may proceed to file a Claim under Section D.3, Claims Review Process. If the Contractor fails to perform the obligations of Sections A.4.1 to A.4.3, the Contractor shall pay such costs and damages to the Owner as would have been avoided if the Contractor had performed such obligations.

A.5 INDEPENDENT CONTRACTOR STATUS

The service or services to be performed under this Contract are those of an independent contractor as defined in ORS 670.600. Contractor represents and warrants that it is not an officer, employee or agent of the Owner as those terms are used in ORS 30.265.

A.6 RETIREMENT SYSTEM STATUS AND TAXES

Contractor represents and warrants that it is not a contributing member of the Public Employees' Retirement System and will be responsible for any federal or state taxes applicable to payment received under this Contract. Contractor will not be eligible for any benefits from these Contract payments of federal Social Security, employment insurance, workers' compensation or the Public Employees' Retirement System, except as a self-employed individual. Unless the Contractor is subject to backup withholding, Owner will not withhold from such payments any amount(s) to cover Contractor's federal or state tax obligations.

A.7 GOVERNMENT EMPLOYMENT STATUS

A.7.1 If this payment is to be charged against federal funds, Contractor represents and warrants that it is not currently employed by the Federal Government. This does not preclude the Contractor from holding another contract with the Federal Government.

A.7.2 Contractor represents and warrants that Contractor is not an employee of the State of Oregon for purposes of performing Work under this Contract.

SECTION B ADMINISTRATION OF THE CONTRACT

B.1 OWNER'S ADMINISTRATION OF THE CONTRACT

B.1.1 The Owner shall administer the Contract as described in the Contract Documents (1) during construction (2) until final payment is due and (3) during the one-year period for correction of Work. The Owner will act as provided in the Contract Documents, unless modified in writing in accordance with other provisions of the Contract. In performing these tasks, the Owner may rely on the Architect/Engineer or other consultants to perform some or all of these tasks.

B.1.2 The Owner will visit the site at intervals appropriate to the stage of the Contractor's operations (1) to become generally familiar with and to keep the Owner informed about the progress and quality of the portion of the Work completed, (2) to endeavor to guard the Owner against defects and deficiencies in the Work, and (3) to determine in general if Work is being performed in a manner indicating that the Work, when fully completed, will be in accordance with the Contract Documents. The Owner will not make exhaustive or continuous on-site inspections to check the quality or quantity of the Work. The Owner will neither have control over or charge of, nor be responsible for the construction means, methods, techniques, sequences or procedures, or for the safety precautions and programs in connection with the Work.

B.1.3 Except as otherwise provided in the Contract Documents or when direct communications have been specifically authorized, the Owner and Contractor shall communicate with each other about matters arising out of or relating to the Contract. Communications by and with the Architect/Engineer's consultants shall be through the Architect/Engineer. Communications by and with Subcontractors and material suppliers shall be through the Contractor. Communications by and with separate contractors shall be through the Owner.

B.1.4 Based upon the Architect/Engineer's evaluations of the Contractor's Application for Payment, or unless otherwise stipulated by the Owner, the Architect/Engineer will review and

certify the amounts due the Contractor and will issue Certificates for Payment in such amounts.

B.2 CONTRACTOR'S MEANS AND METHODS; MITIGATION OF IMPACTS

- B.2.1 The Contractor shall supervise and direct the Work, using the Contractor's best skill and attention. The Contractor shall be solely responsible for and have control over construction means, methods, techniques, sequences and procedures and for coordinating all portions of the Work under the Contract, unless the Contract Documents give other specific instructions concerning these matters. If the Contract Documents give specific instructions concerning construction means, methods, techniques, sequences or procedures, the Contractor shall evaluate the jobsite safety thereof and, except as stated below, shall be fully and solely responsible for the jobsite safety of such means, methods, techniques, sequences or procedures.
- B.2.2 The Contractor is responsible to protect and maintain the Work during the course of construction and to mitigate any adverse impacts to the project, including those caused by authorized changes, which may affect cost, schedule, or quality.
- B.2.3 The Contractor is responsible for the actions of all its personnel, laborers, suppliers, and Subcontractors on the project. The Contractor shall enforce strict discipline and good order among Contractor's employees and other persons carrying out the Work. The Contractor shall not permit employment of persons who are unfit or unskilled for the tasks assigned to them.

B.3 MATERIALS AND WORKMANSHIP

- B.3.1 The intent of the Contract Documents is to provide for the construction and completion in every detail of the Work described. All Work shall be performed in a professional manner and unless the means or methods of performing a task are specified elsewhere in the Contract Documents, Contractor shall employ methods that are generally accepted and used by the industry, in accordance with industry standards.
- B.3.2 The Contractor is responsible to perform the Work as required by the Contract Documents. Defective Work shall be corrected at the Contractor's expense.
- B.3.3 Work done and materials furnished shall be subject to inspection and/or observation and testing by the Owner to determine if they conform to the Contract Documents. Inspection of the Work by the Owner does not relieve the Contractor of responsibility for the Work in accordance with the Contract Documents.
- B.3.4 Contractor shall furnish adequate facilities, as required, for the Owner to have safe access to the Work including without limitation walkways, railings, ladders, tunnels, and platforms. Producers, suppliers, and fabricators shall also provide proper facilities and access to their facilities.
- B.3.5 The Contractor shall furnish Samples of materials for testing by the Owner and include the cost of the Samples in the Contract Price.

B.4 PERMITS

Contractor shall obtain and pay for all necessary permits, licenses and fees, except for those specifically excluded in the Retainer Supplemental General Conditions, for the construction of the Work, for temporary obstructions, enclosures, opening of streets for pipes, walls, utilities, environmental Work, etc., as required for the project. Contractor shall be responsible for all violations of the law, in connection with the construction or caused by obstructing streets, sidewalks or otherwise. Contractor shall give all requisite notices to public authorities.

B.5 COMPLIANCE WITH GOVERNMENT REGULATIONS

- B.5.1 Contractor shall comply with Applicable Laws pertaining to the Work and the Contract. Failure to comply with such requirements shall constitute a breach of Contract and shall be grounds for Contract termination. Without limiting the generality of the foregoing, Contractor expressly agrees to comply with the following, as applicable:
- (i) Title VI and VII of Civil Rights Act of 1964, as amended; (ii) Section 503 and 504 of the Rehabilitation Act of 1973, as amended; (iii) the Health Insurance Portability and Accountability Act of 1996; (iv) the Americans with Disabilities Act of 1990, as amended; (v) ORS Chapter 659A; as amended; (vi) all regulations and administrative rules established pursuant to the foregoing laws; and (vii) all other applicable requirements of federal and state civil rights and rehabilitation statutes, rules and regulations.
- B.5.2 Contractor shall comply with all applicable requirements of federal and state civil rights and rehabilitation statutes, rules and regulations, and
- (a) Contractor shall not discriminate against Disadvantaged, Minority, Women or Emerging Small Business enterprises, as those terms are defined in ORS 200.005, or a business enterprise that is owned or controlled by or that employs a disabled veteran, as that term is defined in ORS 408.225, in the awarding of subcontracts.
- (b) Contractor shall maintain, in current and valid form, all licenses and certificates required by Applicable Laws or this Contract when performing the Work.
- B.5.3 Unless contrary to federal law, Contractor shall certify that it shall not accept a bid from Subcontractors to perform Work as described in ORS 701.005 under this Contract unless such Subcontractors are registered with the Construction Contractors Board in accordance with ORS 701.035 to 701.055 at the time they submit their bids to the Contractor.
- B.5.4 Unless contrary to federal law, Contractor shall certify that each landscape contractor, as defined in ORS 671.520(2), performing Work under this Contract holds a valid landscape contractor's license issued pursuant to ORS 671.560.
- B.5.5 The following notice is applicable to Contractors who perform excavation Work. ATTENTION: Oregon law requires you to follow rules adopted by the Oregon Utility Notification Center. Those rules are set forth in OAR 952-001-0010 through OAR 952-001-0090. You may obtain copies of the rules by calling the center at (503)232-1987.
- B.5.6 Failure to comply with any or all of the requirements of B.5.1 through B.5.5 shall be a breach of Contract and constitute grounds for Contract termination. Damages or costs resulting from such noncompliance shall be the responsibility of Contractor.

B.6 SUPERINTENDENCE

Contractor shall keep on the site, during the progress of the Work, a competent superintendent and any necessary assistants who shall be satisfactory to the Owner and who shall represent the Contractor on the site. Directions given to the superintendent by the Owner shall be confirmed in writing to the Contractor.

B.7 INSPECTION

- B.7.1 Owner shall have access to the Work at all times.
- B.7.2 Inspection of the Work will be made by the Owner at its discretion. The Owner will have authority to reject Work that

does not conform to the Contract Documents. Any Work found to be not in conformance with the Contract Documents, in the discretion of the Owner, shall be removed and replaced at the Contractor's expense.

- B.7.3 Contractor shall make or obtain at the appropriate time all tests, inspections and approvals of portions of the Work required by the Contract Documents or by Applicable Laws or orders of public authorities having jurisdiction. Unless otherwise provided, the Contractor shall make arrangements for such tests, inspections and approvals with an independent testing laboratory or entity acceptable to the Owner, or with the appropriate public authority, and shall bear all related costs of tests, inspections and approvals. Tests or inspections conducted pursuant to the Contract Documents shall be made promptly to avoid unreasonable delay in the Work. The Contractor shall give the Owner timely notice of when and where tests and inspections are to be made so that the Owner may be present for such procedures. Required certificates of testing, inspection or approval shall, unless otherwise required by the Contract Documents, be secured by the Contractor and promptly delivered to the Owner.
- B.7.4 As required by the Contract Documents, Work done or material used without required inspection or testing and/or without providing timely notice to the Owner may be ordered removed at the Contractor's expense.
- B.7.5 If directed to do so any time before the Work is accepted, the Contractor shall uncover portions of the completed Work for inspection. After inspection, the Contractor shall restore such portions of Work to the standard required by the Contract. If the Work uncovered is unacceptable or was done without required testing or inspection or sufficient notice to the Owner, the uncovering and restoration shall be done at the Contractor's expense. If the Work uncovered is acceptable and was done with sufficient notice to the Owner, the uncovering and restoration will be paid for pursuant to a Supplement Amendment.
- B.7.6 If any testing or inspection reveals failure of the portions of the Work to comply with requirements established by the Contract Documents, all costs made necessary by such failure, including those of repeated procedures and compensation for the Owner's and Architect/Engineer's services and expenses, shall be at the Contractor's expense.
- B.7.7 When the United States government participates in the cost of the Work, or the Owner has an agreement with other public or private organizations, or if any portion of the Work is being performed for a third party or in close proximity to third party facilities, representatives of these organizations shall have the right to inspect the Work affecting their interests or property. Their right to inspect shall not make them a party to the Contract and shall not interfere with the rights of the parties of the Contract. Instructions or orders of such parties shall be transmitted to the Contractor, through the Owner.

B.8 SEVERABILITY

If any provision of this Contract is declared by a court to be illegal or in conflict with any law, the validity of the remaining terms and provisions shall not be affected and the rights and obligations of the parties shall be construed and enforced as if the Contract did not contain the particular provision held to be invalid.

B.9 ACCESS TO RECORDS

- B.9.1 Contractor shall keep, at all times on the Work site, one record copy of the complete Contract Documents, including the Plans, Specifications, Construction Change Directives and addenda, in good order and marked currently to record field changes and selections made during construction, and one record copy of

Shop Drawings, Product Data, Samples and similar submittals, and shall at all times give the Owner access thereto.

- B.9.2 Contractor shall retain and the Owner and its duly authorized representatives shall have access, for a period not less than ten (10) years, to all Record Documents, financial and accounting records, and other books, documents, papers and records of Contractor which are pertinent to the Contract, including records pertaining to Overhead and indirect costs, for the purpose of making audit, examination, excerpts and transcripts. If for any reason, any part of the Work or this Contract shall be subject to litigation, Contractor shall retain all such records until all litigation is resolved and Contractor shall continue to provide Owner and/or its agents with full access to such records until such time as all litigation is complete and all periods for appeal have expired and full and final satisfaction of any judgment, order or decree is recorded and Owner receives a record copy of documentation from Contractor.

B.10 WAIVER

Failure of the Owner to enforce any provision of this Contract shall not constitute a waiver or relinquishment by the Owner of the right to such performance in the future nor of the right to enforce any other provision of this Contract.

B.11 SUBCONTRACTS AND ASSIGNMENT

- B.11.1 Contractor shall require each Subcontractor, to the extent of the Work to be performed by the Subcontractor, to be bound by the terms and conditions of these OUS Retainer General Conditions, and to assume toward the Contractor all of the obligations and responsibilities which the Contractor assumes toward the Owner thereunder, unless (1) the same are clearly inapplicable to the subcontract at issue because of legal requirements or industry practices, or (2) specific exceptions are requested by Contractor and approved in writing by Owner. Where appropriate, Contractor shall require each Subcontractor to enter into similar agreements with sub-subcontractors at any level.
- B.11.2 At Owner's request, Contractor shall submit to Owner prior to their execution either Contractor's form of subcontract, or the subcontract to be executed with any particular Subcontractor. If Owner disapproves such form, Contractor shall not execute the form until the matters disapproved are resolved to Owner's satisfaction. Owner's review, comment upon or approval of any such form shall not relieve Contractor of its obligations under this Agreement or be deemed a waiver of such obligations of Contractor.
- B.11.3 Contractor shall not assign, sell, or transfer its rights, or delegate its responsibilities under this Contract, in whole or in part, without the prior written approval of the Owner. No such written approval shall relieve Contractor of any obligations of this Contract, and any transferee shall be considered the agent of the Contractor and bound to perform in accordance with the Contract Documents. Contractor shall remain liable as between the original parties to the Contract as if no assignment had occurred.

B.12 SUCCESSORS IN INTEREST

The provisions of this Contract shall be binding upon and shall accrue to the benefit of the parties to the Contract and their respective permitted successors and assigns.

B.13 OWNER'S RIGHT TO DO WORK

Owner reserves the right to perform other or additional work at or near the project site with other forces than those of the Contractor. If such work takes place within or next to the project site, Contractor shall coordinate work with the other contractors or forces, cooperate with all

other contractors or forces, carry out the Work in a way that will minimize interference and delay for all forces involved, place and dispose of materials being used so as not to interfere with the operations of another, and join the Work with the work of the others in an acceptable manner and perform it in proper sequence to that of the others. The Owner will resolve any disagreements that may arise between or among Contractor and the other contractors over the method or order of doing all work (including the Work). In case of unavoidable interference, the Owner will establish work priority (including the Work) which generally will be in the sequence that the contracts were awarded.

B.14 OTHER CONTRACTS

In all cases and at any time, the Owner has the right to execute other contracts related to or unrelated to the Work of this Contract. The Contractor of this Contract shall fully cooperate with any and all other contractors without additional cost to the Owner in the manner described in section B.13.

B.15 GOVERNING LAW

This Contract shall be governed by and construed in accordance with the laws of the State of Oregon without regard to principles of conflict of laws.

B.16 LITIGATION

Any Claim between Owner and Contractor that arises from or relates to this Contract and that is not resolved through the Claims Review Process in Section D.3 shall be brought and conducted solely and exclusively within the Circuit Court of Marion County for the State of Oregon; provided, however, if a Claim must be brought in a federal forum, then it shall be brought and conducted solely and exclusively within the United States District Court for the District of Oregon. In no event shall this section be construed as a waiver by the State of Oregon of any form of defense or immunity, whether sovereign immunity, governmental immunity, immunity based on the Eleventh Amendment to the Constitution of the United States or otherwise, from any claim or from the jurisdiction of any court. CONTRACTOR, BY EXECUTION OF THIS CONTRACT, HEREBY CONSENTS TO THE IN PERSONAM JURISDICTION OF THE COURTS REFERENCED IN THIS SECTION B.16.

B.17 ALLOWANCES

B.17.1 The Contractor shall include in the Contract Price all allowances stated in the Contract Documents. Items covered by allowances shall be supplied for such amounts and by such persons or entities as the Owner may direct.

B.17.2 Unless otherwise provided in the Contract Documents:

- (a) when finally reconciled, allowances shall cover the cost to the Contractor of materials and equipment delivered at the site and all required taxes, less applicable trade discounts;
- (b) Contractor's costs for unloading and handling at the site, labor, installation costs, Overhead, profit and other expenses contemplated for stated allowance amounts shall be included in the Contract Price but not in the allowances;
 - (c) whenever costs are more than or less than allowances, the Contract Price shall be adjusted accordingly by Amendment. The amount of the Amendment shall reflect (i) the difference between actual costs and the allowances under Section B.17.2(a) and (2) changes in Contractor's costs under Section B.17.2(b).
- (d) Unless Owner requests otherwise, Contractor shall provide to Owner a proposed fixed price for any allowance work prior to its performance.

B.18 SUBMITTALS, SHOP DRAWINGS, PRODUCT DATA AND SAMPLES

B.18.1 The Contractor shall prepare and keep current, for the Architect's/Engineer's approval (or for the approval of Owner if approval authority has not been delegated to the Architect/Engineer), a schedule and list of submittals which is coordinated with the Contractor's construction schedule and allows the Architect/Engineer reasonable time to review submittals. Owner reserves the right to finally approve the schedule and list of submittals. Submittals include, without limitation, Shop Drawings, Product Data, and Samples which are described below:

- (a) Shop Drawings are drawings, diagrams, schedules and other data specially prepared for the Work by the Contractor or a Subcontractor (including any sub-subcontractor), manufacturer, supplier or distributor to illustrate some portion of the Work.
- (b) Product Data are illustrations, standard schedules, performance charts, instructions, brochures, diagrams and other information furnished by the Contractor to illustrate materials or equipment for some portion of the Work.
- (c) Samples are physical examples which illustrate materials, equipment or workmanship and establish standards by which the Work will be judged.

B.18.2 Shop Drawings, Product Data, Samples and similar submittals are not Contract Documents. The purpose of their submittal is to demonstrate for those portions of the Work for which submittals are required by the Contract Documents the way by which the Contractor proposes to conform to the information given and the design concept expressed in the Contract Documents. Review of submittals by the Architect/Engineer is not conducted for the purpose of determining the accuracy and completeness of other details such as dimensions and quantities, or for substantiating instructions for installation or performance of equipment or systems, or for approval of safety precautions or, unless otherwise specifically stated by the Architect/Engineer, of any construction means, methods, techniques, sequences or procedures, all of which remain the responsibility of the Contractor as required by the Contract Documents. The Architect/Engineer's review of the Contractor's submittals shall not relieve the Contractor of its obligations under the Contract Documents. The Architect/Engineer's approval of a specific item shall not indicate approval of an assembly of which the item is a component. Informational submittals upon which the Architect/Engineer is not expected to take responsive action may be so identified in the Contract Documents. Submittals which are not required by the Contract Documents may be returned by the Architect/Engineer without action.

B.18.3 The Contractor shall review for compliance with the Contract Documents, approve and submit to the Architect/Engineer Shop Drawings, Product Data, Samples and similar submittals required by the Contract Documents with reasonable promptness and in such sequence as to cause no delay in the Work or in the activities of the Owner or of separate contractors. Submittals which are not marked as reviewed for compliance with the Contract Documents and approved by the Contractor may be returned by the Architect/Engineer without action.

B.18.4 By approving and submitting Shop Drawings, Product Data, Samples and similar submittals, the Contractor represents that the Contractor has determined and verified materials, field measurements and field construction criteria related thereto, or will do so, and has checked and coordinated the information contained within such submittals with the requirements of the Work and of the Contract Documents.

B.18.5 The Contractor shall perform no portion of the Work for which the Contract Documents require submittal and review of Shop Drawings, Product Data, Samples or similar submittals until the respective submittal has been approved by the Architect/Engineer.

B.18.6 The Work shall be in accordance with approved submittals except that the Contractor shall not be relieved of responsibility for deviations from requirements of the Contract Documents by the Architect/Engineer's review or approval of Shop Drawings, Product Data, Samples or similar submittals unless the Contractor has specifically informed the Architect/Engineer in writing of such deviation at the time of submittal and (i) the Architect/Engineer has given written approval to the specific deviation as a minor change in the Work, or (ii) a Supplement Amendment or Construction Change Directive has been executed by Owner authorizing the deviation. The Contractor shall not be relieved of responsibility for errors or omissions in Shop Drawings, Product Data, Samples or similar submittals by the Architect/Engineer's review or approval thereof.

B.18.7 In the event that Owner elects not to have the obligations and duties described under this Section B.18 performed by the Architect/Engineer, or in the event no Architect/Engineer is employed by Owner on the project, all obligations and duties assigned to the Architect/Engineer hereunder shall be performed by the Owner.

B.19 SUBSTITUTIONS

The Contractor may make Substitutions only with the consent of the Owner, after evaluation by the Owner and only in accordance with a Supplement Amendment or Construction Change Directive. Substitutions shall be subject to the requirements of the bid documents. By making requests for Substitutions, the Contractor: represents that the Contractor has personally investigated the proposed substitute product; represents that the Contractor will provide the same warranty for the Substitution that the Contractor would for the product originally specified unless approved otherwise; certifies that the cost data presented is complete and includes all related costs under this Contract including redesign costs, and waives all claims for additional costs related to the Substitution which subsequently become apparent; and will coordinate the installation of the accepted Substitution, making such changes as may be required for the Work to be completed in all respects.

B.20 USE OF PLANS AND SPECIFICATIONS

Plans, Specifications and related Contract Documents furnished to Contractor by Owner or Owner's Architect/Engineer shall be used solely for the performance of the Work under this Contract. Contractor and its Subcontractors and suppliers are authorized to use and reproduce applicable portions of such documents appropriate to the execution of the Work, but shall not claim any ownership or other interest in them beyond the scope of this Contract, and no such interest shall attach. Unless otherwise indicated, all common law, statutory and other reserved rights, in addition to copyrights, are retained by Owner.

B.21 FUNDS AVAILABLE AND AUTHORIZED

Owner reasonably believes at the time of entering into this Contract that sufficient funds are available and authorized for expenditure to finance the cost of this Contract within the Owner's appropriation or limitation. Contractor understands and agrees that, to the extent that sufficient funds are not available and authorized for expenditure to finance the cost of this Contract, Owner's payment of amounts under this Contract attributable to Services performed after the last day of the current biennium is contingent on Owner receiving from the Oregon Legislative Assembly appropriations, limitations or other expenditure authority sufficient to allow Owner, in the exercise of its reasonable administrative discretion, to continue to make payments under this Contract.

B.22 NO THIRD PARTY BENEFICIARIES

Owner and Contractor are the only parties to this Contract and are the only parties entitled to enforce its terms. Nothing in this Contract gives, is intended to give, or shall be construed to give or provide any benefit or right, whether directly, indirectly, or otherwise, to third persons unless such third persons are individually identified by name herein and expressly described as intended beneficiaries of the terms of this Contract.

SECTION C WAGES AND LABOR

C.1 MINIMUM WAGE RATES ON PUBLIC WORKS

Contractor shall comply fully with the provisions of ORS 279C.800 through 279C.870. Documents establishing those conditions, as determined by the Commissioner of the Bureau of Labor and Industries (BOLI), are included as attachments to or are incorporated by reference in the Contract Documents. Pursuant to ORS 279C.830(1)(d), Contractor shall pay workers at not less than the specified minimum hourly rate of wage, and shall include that requirement in all subcontracts. If the Work is subject to both the state prevailing wage rate law and the federal Davis-Bacon Act, Contractor shall pay the higher of the applicable state or federal prevailing rate of wage. Contractor shall provide written notice to all workers of the number of hours per day and days per week such workers may be required to work.

C.2 PAYROLL CERTIFICATION AND FEE REQUIREMENTS

C.2.1 In accordance with ORS 279C.845, the Contractor and every Subcontractor shall submit written certified statements to the Owner, on the form prescribed by the Commissioner of the Bureau of Labor and Industries, certifying the hourly rate of wage paid each worker which the Contractor or the Subcontractor has employed on the project and further certifying that no worker employed on the project has been paid less than the prevailing rate of wage or less than the minimum hourly rate of wage specified in the Contract, which certificate and statement shall be verified by the oath of the Contractor or the Subcontractor that the Contractor or Subcontractor has read the certified statement, that the Contractor or Subcontractor knows the contents of the certified statement, and, that to the Contractor's or Subcontractor's best knowledge and belief, the certified statement is true. The certified statements shall set out accurately and completely the payroll records for the prior week, including the name and address of each worker, the worker's correct classification, rate of pay, daily and weekly number of hours worked, deductions made, and actual wages paid. Certified statements for each week during which the Contractor or Subcontractor has employed a worker on the project shall be submitted once a month, by the fifth business day of the following month. The Contractor and Subcontractors shall preserve the certified statements for a period of ten (10) years from the date of completion of the Contract.

C.2.2 Pursuant to ORS 279C.845(7), the Owner shall retain 25 percent of any amount earned by the Contractor on this public works project until the Contractor has filed the certified statements required by section C.2.1. The Owner shall pay to the Contractor the amount retained under this subsection within 14 days after the Contractor files the required certified statements, regardless of whether a Subcontractor has failed to file certified statements.

C.2.3 Pursuant to ORS 279C.845(8), the Contractor shall retain 25 percent of any amount earned by a first-tier Subcontractor on this public works project until the first-tier Subcontractor has

filed with the Owner the certified statements required by C.2.1. Before paying any amount retained under this subsection, the Contractor shall verify that the first-tier Subcontractor has filed the certified statement. Within 14 days after the first-tier Subcontractor files the required certified statement the Contractor shall pay the first-tier Subcontractor any amount retained under this subsection.

- C.2.4 In accordance with statutory requirements and administrative rules promulgated by the Commissioner of the Bureau of Labor and Industries, the fee required by ORS 279C.825(1) will be paid by Owner to the Commissioner.

C.3 PROMPT PAYMENT AND CONTRACT CONDITIONS

C.3.1 As a condition to Owner's performance hereunder, the Contractor shall:

C.3.1.1 Make payment promptly, as due, to all persons supplying to Contractor labor or materials for the prosecution of the Work provided for in this Contract.

C.3.1.2 Pay all contributions or amounts due the State Industrial Accident Fund from such Contractor or Subcontractor incurred in the performance of the Contract.

C.3.1.3 Not permit any lien or claim to be filed or prosecuted against the Owner on account of any labor or material furnished. Contractor will not assign any claims that Contractor has against Owner, or assign any sums due by Owner, to Subcontractors, suppliers, or manufacturers, and will not make any agreement or act in any way to give Subcontractors a claim or standing to make a claim against the Owner.

C.3.1.4 Pay to the Department of Revenue all sums withheld from employees pursuant to ORS 316.167.

C.3.2 As a condition to Owner's performance hereunder, if Contractor fails, neglects or refuses to make prompt payment of any claim for labor or services furnished to the Contractor or a Subcontractor by any person in connection with the project as such claim becomes due, the proper officer(s) representing the Owner may pay the claim and charge the amount of the payment against funds due or to become due Contractor under this Contract. Payment of claims in this manner shall not relieve the Contractor or the Contractor's surety from obligation with respect to any unpaid claims.

C.3.3 Contractor shall include in each subcontract for property or services entered into by the Contractor and a first-tier subcontractor, including a material supplier, for the purpose of performing a construction contract, a payment clause that obligates the Contractor to pay the first-tier Subcontractor for satisfactory performance under its subcontract within ten (10) Days out of such amounts as are paid to the Contractor by the public contracting agency under such contract.

C.3.4 All employers, including Contractor, that employ subject workers who work under this contract in the State of Oregon shall comply with ORS 656.017 and provide the required Workers' Compensation coverage, unless such employers are exempt under ORS 656.126. Contractor shall ensure that each of its Subcontractors complies with these requirements.

C.4 PAYMENT FOR MEDICAL CARE

As a condition to Owner's performance hereunder, Contractor shall promptly, as due, make payment to any person, partnership, association or corporation furnishing medical, surgical, and hospital care or other needed care and attention, incident to sickness or injury, to the employees of such Contractor, all sums of which the Contractor

agrees to pay for such services and all moneys and sums which the Contractor has collected or deducted from the wages of personnel pursuant to any law, contract or agreement for the purpose of providing or paying for such services.

C.5 HOURS OF LABOR

As a condition to Owner's performance hereunder, no person shall be employed to perform Work under this Contract for more than ten (10) hours in any one day or forty (40) hours in any one week, except in cases of necessity, emergency or where public policy absolutely requires it. In such instances, Contractor shall pay the employee at least time and a half pay:

(a) For all overtime in excess of eight (8) hours a day or forty (40) hours in any one week when the work week is five consecutive Days, Monday through Friday; or

(b) For all overtime in excess of ten (10) hours a day or forty (40) hours in any one week when the work week is four consecutive Days, Monday through Friday; and

(c) For all Work performed on Saturday and on any legal holiday specified in ORS 279C.540.

This section C.5 will not apply to Contractor's Work under this Contract to the extent Contractor is currently a party to a collective bargaining agreement with any labor organization.

This Section C.5 shall not excuse Contractor from completion of the Work within the time required under this Contract.

SECTION D CHANGES IN THE WORK

D.1 CHANGES IN WORK

D.1.1 The terms of this Contract shall not be waived, altered, modified, supplemented or amended in any manner whatsoever, without prior written agreement and then only after any necessary approvals have been obtained. A Supplement or Amendment is required, which shall not be effective until its execution by the parties to this Contract and all approvals required by public contracting laws have been obtained.

D.1.2 It is mutually agreed that changes in Plans, quantities, or details of construction are inherent in the nature of construction and may be necessary or desirable during the course of construction. Within the general scope of this Contract, the Owner may at any time, without notice to the sureties and without impairing the Contract, require changes consistent with this Section D.1. All changes to the Work shall be documented and Amendments shall be executed under the conditions of the Contract Documents. Such changes may include, but are not limited to:

- (a) Modification of specifications and design.
- (b) Increases or decreases in quantities.
- (c) Increases or decreases to the amount of Work.
- (d) Addition or elimination of any Work item.
- (e) Change in the duration of the project.
- (f) Acceleration or delay in performance of Work.
- (g) Deductive changes.

Deductive changes are those that reduce the scope of the Work, and shall be made by mutual agreement whenever feasible. In cases of suspension or partial termination under Section J, Owner reserves the right to unilaterally impose a deductive change and to self perform such Work, for which the provisions of B.13 (Owner's Right to Do Work) shall then apply. Adjustments in compensation shall be made under the provisions of D.1.3, in which costs for deductive changes shall be based upon a Direct Costs adjustment together with the related

percentage markup specified for profit, Overhead and other indirect costs, unless otherwise agreed to by Owner.

D.1.3 The Owner and Contractor agree that adjustments to or deletions from the Work shall be administered and compensated according to the following:

- (a) Unit pricing may be utilized at the Owner's option when unit prices or solicitation alternates were provided that established the cost for adjustments to Work, and a binding obligation exists under the Contract on the parties covering the terms and conditions of the adjustment to Work.
- (b) If the Owner elects not to utilize unit pricing, or in the event that unit pricing is not available or appropriate, fixed pricing may be used for adjustments to or deletions from the Work. In fixed pricing the basis of payments or total price shall be agreed upon in writing between the parties to the Contract, and shall be established before the Work is done whenever feasible. Notwithstanding the foregoing, the mark-ups set forth in D.1.3(c) shall be utilized in establishing fixed pricing, and such mark-ups shall not be exceeded. Cost and price data relating to adjustments to or deletions from the Work shall be supplied by Contractor to Owner upon request, but Owner shall be under no obligation to make such requests.
- (c) In the event that unit pricing and fixed pricing are not utilized, then adjustments to or deletions from the Work shall be performed on a cost reimbursement basis for Direct Costs. Such Work shall be compensated on the basis of the actual, reasonable and allowable cost of labor, equipment, and material furnished on the Work performed. In addition, the following markups shall be added to the Contractor's or Subcontractor's Direct Costs as full compensation for profit, Overhead and other indirect costs for Work directly performed with the Contractor's or Subcontractor's own forces:

On Labor.....	15%
On Equipment.....	10%
On Materials.....	10%

- (d) When adjustments to or deletions from the Work under D.1.3(c) are invoiced by an authorized Subcontractor at any level, each ascending tier Subcontractor or Contractor will be allowed a supplemental mark-up on each piece of subcontract Work covered by a an Amendment as follows:

\$0.00 - \$5,000.00	10%, and then
Over \$5,000.00	5%

Payments made to the Contractor shall be complete compensation for Overhead, profit, and all costs that were incurred by the Contractor or by other forces furnished by the Contractor, including Subcontractors, for adjustments to or deletions from the Work pursuant to a Supplement Amendment. Owner may establish a maximum cost for additional Work under this Section D.1.3, which shall not be exceeded for reimbursement without additional written authorization from Owner in the form of a Supplement Amendment. Contractor shall not be required to complete such additional Work without additional authorization.

D.1.4 Any necessary adjustment of Contract Time that may be required as a result of adjustments to or deletions from the Work must be agreed upon by the parties before the start of the revised Work unless Owner authorizes Contractor to start the revised Work before agreement on Contract Time adjustment. Contractor shall submit any request for additional compensation (and additional Contract Time if Contractor was authorized to start Work before an adjustment of Contract Time was

approved) as soon as possible but no later than thirty (30) Days after receipt of Owner's request for additional Work. If Contractor's request for additional compensation or adjustment of Contract Time is not made within the thirty (30) Day time limit, Contractor's requests pertaining to that additional Work shall be barred. The thirty (30) Day time limit for making requests shall not be extended for any reason, including without limitation Contractor's claimed inability to determine the amount of additional compensation or adjustment of Contract Time, unless an extension is granted in writing by Owner. If the Owner denies Contractor's request for additional compensation or adjustment of Contract Time, Contractor may proceed to file a Claim under Section D.3, Claims Review Process. No other reimbursement, compensation, or payment will be made, except as provided in Section D.1.5 for impact claims.

D.1.5 If any adjustment to Work under Section D.1.3 causes an increase or decrease in the Contractor's cost of, or the Contract Time required for the performance of any other part of the Work under this Contract, Contractor shall submit a written request to the Owner, setting forth the nature and specific extent of the request, including all time and cost impacts against the Contract as soon as possible, but no later than thirty (30) Days after receipt of Owner's request for adjustments to or deletions from the Work by Contractor.

The thirty (30) Day time limit applies to claims of Subcontractors, suppliers, or manufacturers who may be affected by Owner's request for adjustments to or deletions from the Work and who request additional compensation or an extension of Contract Time to perform; Contractor has responsibility for contacting its Subcontractors, suppliers, or manufacturers within the thirty (30) Day time limit, and including their requests with Contractor's requests. If the request involves Work to be completed by Subcontractors, or materials to be furnished by suppliers or manufacturers, such requests shall be submitted to the Contractor in writing with full analysis and justification for the adjustments to compensation and Contract Time requested. The Contractor shall analyze and evaluate the merits of the requests submitted by Subcontractors, suppliers, and manufacturers to Contractor prior to including those requests and Contractor's analysis and evaluation of those requests with Contractor's requests for adjustments to compensation or Contract Time that Contractor submits to the Owner. Failure of Subcontractors, suppliers, manufacturers or others to submit their requests to Contractor for inclusion with Contractor's requests submitted to Owner within the time period and by the means described in this section shall constitute a waiver of these Subcontractor claims. The Owner will not consider direct requests or claims from Subcontractors, suppliers, manufacturers or others not a party to this Contract. The consideration of such requests and claims under this section does not give any Person, not a party to the Contract the right to bring a claim against Owner, whether in this claims process, in litigation, or in any dispute resolution process.

If the Owner denies the Contractor's request for adjustment to compensation or Contract Time, the Contractor may proceed to file a Claim under Section D.3, Claims Review Process.

D.1.6 No request or Claim by the Contractor for additional costs or an adjustment of Contract Time shall be allowed if made after receipt of final payment application under this Contract. Final payment application must be made by Contractor within the time required under Section E.6.4.

D.1.7 It is understood that changes in the Work are inherent in construction of this type. The number of changes, the scope of those changes, and the effect they have on the progress of the original Work cannot be defined at this time. The Contractor is notified that numerous changes may be required and that there will be no compensation made, unless and only to the extent otherwise provided in the Contract Documents, to the Contractor

directly related to the number of changes. Each change will be evaluated for extension of Contract Time and increase or decrease in compensation based on its own merit.

D.2 DELAYS

D.2.1 Delays in construction include "Avoidable Delays", which are defined in Section D.2.1.1, and "Unavoidable Delays", which are defined in Section D.2.1.2. The effect of Avoidable Delays is described in Section D.2.2 and the effect of Unavoidable Delays is described in Section D.2.3.

D.2.1.1 Avoidable Delays include any delays other than Unavoidable Delays, and include delays that otherwise would be considered Unavoidable Delays but that:

- (a) Could have been avoided by the exercise of care, prudence, foresight, and diligence on the part of the Contractor or its Subcontractors.
- (b) Affect only a portion of the Work and do not necessarily prevent or delay the prosecution of neither other parts of the Work nor the completion of the whole Work within the Contract Time.
- (c) Do not impact activities on the accepted critical path schedule.
- (d) Are associated with the reasonable interference of other contractors employed by the Owner that do not necessarily prevent the completion of the whole Work within the Contract Time.

D.2.1.2 Unavoidable Delays include delays other than Avoidable Delays that are:

- (a) To the extent caused by any actions of the Owner, or any other employee or agent of the Owner, or by separate contractor employed by the Owner.
- (b) To the extent caused by any site conditions which differ materially from what was represented in the Contract Documents or from conditions that would normally be expected to exist and be inherent to the construction activities defined in the Contract Documents. The Contractor shall notify the Owner immediately of differing site conditions before the area has been disturbed. The Owner will investigate the area and make a determination as to whether or not the conditions differ materially from either the conditions stated in the Contract Documents or those which could reasonably be expected in execution of this particular Contract. If Contractor and the Owner agree that a differing site condition exists, any adjustment to compensation or Contract Time will be determined based on the process set forth in Section D.1.5 for adjustments to or deletions from Work. If the Owner disagrees that a differing site condition exists and denies Contractor's request for additional compensation or Contract Time, Contractor may proceed to file a Claim under Section D.3, Claims Review Process.
- (c) To the extent caused by Force Majeure acts, events or occurrences that could not have been avoided by the exercise of care, prudence, foresight, and diligence on the part of the Contractor or its Subcontractors.
- (d) To the extent caused by adverse weather conditions. Any adverse weather conditions must be substantiated by documentary evidence that weather conditions were abnormal for the specific time period claimed, could not have been anticipated by the Contractor, and adversely impacted the project in a manner that could not be avoided by rescheduling the Work or by implementing measures to

protect against the weather so that the Work could proceed. A rain, windstorm, high water, or other natural phenomenon for the specific locality of the Work, which might reasonably have been anticipated from the previous 10-year historical records of the general locality of the Work, shall not be construed as abnormal. The parties agree that rainfall greater than the following levels cannot be reasonably anticipated:

- (i) Daily rainfall equal to, or greater than, 0.50 inch during a month when the monthly rainfall exceeds the normal monthly average by twenty-five percent (25 %) or more.
- (ii) daily rainfall equal to, or greater than, 0.75 inch at any time.

The Office of the Environmental Data Service of the National Oceanic and Atmospheric Administration of the U.S. Department of Commerce nearest the project site shall be considered the official agency of record for weather information.

D.2.2 Contractor shall not be entitled to additional compensation or additional Contract Time for Avoidable Delays.

D.2.3 In the event of Unavoidable Delays, based on principles of equitable adjustment, Contractor may be entitled to the following:

- (a) Contractor may be entitled to additional compensation or additional Contract Time, or both, for Unavoidable Delays described in Section D.2.1.2 (a) and (b).
- (b) Contractor may be entitled to additional Contract Time for Unavoidable Delays described in Section D.2.1.2(c) and (d).

In the event of any requests for additional compensation or additional Contract Time, or both, as applicable, arising under this Section D.2.3 for Unavoidable Delays, other than requests for additional compensation or additional Contract Time for differing site conditions for which a review process is established under Section D.2.1.2 (b), Contractor shall submit a written notification of the delay to the Owner within two (2) Days of the occurrence of the cause of the delay. This written notification shall state the cause of the potential delay, the project components impacted by the delay, and the anticipated additional Contract Time extension or the additional compensation, or both, as applicable, resulting from the delay. Within seven (7) Days after the cause of the delay has been mitigated, or in no case more than thirty (30) Days after the initial written notification, the Contractor shall submit to the Owner, a complete and detailed request for additional compensation or additional Contract Time, or both, as applicable, resulting from the delay. If the Owner denies Contractor's request for additional compensation or adjustment of Contract Time, the Contractor may proceed to file a Claim under Section D.3, Claims Review Process.

If Contractor does not timely submit the notices required under this Section D.2, then unless otherwise prohibited by law, Contractor's Claim shall be barred.

D.3 CLAIMS REVIEW PROCESS

D.3.1 All Contractor Claims shall be referred to the Owner for review. Contractor's Claims, including Claims for adjustments to compensation or Contract Time, shall be submitted in writing by Contractor to the Owner within five (5) Days after a denial of Contractor's initial request for an adjustment of Contract terms, payment of money, extension of Contract Time or other relief, provided that such initial request has been submitted in accordance with the requirements and within the time limits

established in these OUS Retainer General Conditions. Within thirty (30) Days after the initial Claim, Contractor shall submit to the Owner a complete and detailed description of the Claim (the "Detailed Notice") that includes all information required by Section D.3.2. Unless the Claim is made in accordance with these time requirements, it shall be waived by Contractor.

- D.3.2 The Detailed Notice of the Claim shall be submitted in writing by Contractor and shall include a detailed, factual statement of the basis of the Claim, pertinent dates, Contract provisions which support or allow the Claim, reference to or copies of any documents which support the Claim, the dollar value of the Claim, and the Contract Time adjustment requested for the Claim. If the Claim involves Work to be completed by Subcontractors, the Contractor will analyze and evaluate the merits of the Subcontractor claim prior to forwarding it and that analysis and evaluation to the Owner. The Owner will not consider direct claims from Subcontractors, suppliers, manufacturers, or others not a party to this Contract. Contractor agrees that it will make no agreement, covenant, or assignment, nor will it commit any other act that will permit or assist any Subcontractor, supplier, manufacturer, or other to directly or indirectly make a claim against Owner.
- D.3.3 The Owner will review all Claims and take one or more of the following preliminary actions within ten (10) Days of receipt of the Detailed Notice of a Claim: (1) request additional supporting information from the Contractor; (2) inform the Contractor and Owner in writing of the time required for adequate review and response; (3) reject the Claim in whole or in part and identify the reasons for rejection; (4) based on principles of equitable adjustment, recommend approval of all or part of the Claim; or (5) propose an alternate resolution.
- D.3.4 The Owner's decision shall be final and binding on the Contractor unless appealed by written notice to the Owner within fifteen (15) Days of receipt of the decision. The Contractor must present written documentation supporting the Claim within fifteen (15) Days of the notice of appeal. After receiving the appeal documentation, the Owner shall review the materials and render a decision within thirty (30) Days after receiving the appeal documents.
- D.3.5 The decision of the Owner shall be final and binding unless the Contractor delivers to the Owner its request for mediation, which shall be a non-binding process, within fifteen (15) Days of the date of the Owner's decision. The mediation process will be considered to have commenced as of the date the Contractor delivers the request. Both parties acknowledge and agree that participation in mediation is a prerequisite to commencement of litigation of any disputes relating to the Contract. Both parties further agree to exercise their best efforts in good faith to resolve all disputes within sixty (60) Days of the commencement of the mediation through the mediation process set forth herein.
- In the event that a lawsuit must be filed within this sixty (60) Day period in order to preserve a cause of action, the parties agree that, notwithstanding the filing, they shall proceed diligently with the mediation to its conclusion prior to actively prosecuting the lawsuit, and shall seek from the Court in which the lawsuit is pending such stays or extensions, including the filing of an answer, as may be necessary to facilitate the mediation process. Further, in the event settlements are reached on any issues through mediation, the plaintiff shall promptly cause to be entered by the Court a stipulated general judgment of dismissal with prejudice, or other appropriate order limiting the scope of litigation as provided in the settlement.
- D.3.6 Should the parties arrive at an impasse regarding any Claims or disputed Claims, it is agreed that the parties shall participate in mediation as specified in Section D.3.5. The mediation process will be considered to have been commenced as of the date one

party delivers to the other its request in writing to mediate. The mediator shall be an individual mutually acceptable to both parties, but in the absence of agreement each party shall select a temporary mediator and the temporary mediators shall jointly select the permanent mediator. Each party shall pay its own costs for the time and effort involved in mediation. The cost of the mediator shall be split equally between the two parties. Both parties agree to exercise their best effort in good faith to resolve all disputes in mediation. Participation in mediation is a mandatory requirement of both the Owner and the Contractor. The schedule, time and place for mediation will be mutually acceptable, or, failing mutual agreement, shall be as established by the mediator. The parties agree to comply with Owner's administrative rules governing the confidentiality of mediation, if any, and shall execute all necessary documents to give effect to such confidentiality rules. In any event, the parties shall not subpoena the mediator or otherwise require the mediator to produce records, notes or work product, or to testify in any future proceedings as to information disclosed or representations made in the course of mediation, except to the extent disclosure is required by law.

- D.3.7 Unless otherwise directed by Owner, Contractor shall proceed with the Work while any Claim, or mediation or litigation arising from a Claim, is pending. Regardless of the review period or the final decision of the Owner, the Contractor shall continue to diligently pursue the Work as identified in the Contract Documents. In no case is the Contractor justified or allowed to cease or Delay Work, in whole or in part, without a written stop work order from the Owner.

SECTION E PAYMENTS

E.1 SCHEDULE OF VALUES

The Contractor shall submit, at least ten (10) Days prior to submission of its first application for progress payment, a schedule of values ("Schedule of Values") for the contracted Work. This schedule shall provide a breakdown of values for the contracted Work and will be the basis for progress payments. The breakdown shall demonstrate reasonable, identifiable, and measurable components of the Work. Unless objected to by the Owner, this schedule shall be used as the basis for reviewing Contractor's applications for payment. If objected to by Owner, Contractor shall revise the schedule of values and resubmit the same for approval of Owner.

E.2 APPLICATIONS FOR PAYMENT

E.2.1 Owner shall make progress payments on the Contract monthly as Work progresses, in accordance with the requirements of this Section E.2. Applications for payment shall be based upon estimates of Work completed and the Schedule of Values. As a condition precedent to Owner's obligation to pay, all applications for payment shall be approved by the Owner. A progress payment shall not be considered acceptance or approval of any Work or waiver of any defects therein. Owner shall pay to Contractor interest for overdue invoices at the rate of two-thirds of one percent per month on the progress payment, not including retainage, due the Contractor. Overdue invoices will be those that have not been paid within forty five (45) days from the latest of:

- (a) The date of the receipt of the accurate invoice;
- (b) The date Owner receives the correct application for payment if no invoice is received;
- (c) The date all goods and services have been received; or
- (d) The date a Claim is made certain by agreement of the parties or by operation of law.

Notwithstanding the foregoing, in instances when an application for payment is filled out incorrectly, or when there is any defect or impropriety in any submitted application or when there is a good faith dispute, Owner shall so notify the Contractor within fifteen (15) Days stating the reason or reasons the application for payment is defective or improper or the reasons for the dispute. A defective or improper application for payment, if corrected by the Contractor within seven (7) Days of being notified by the Owner, shall not cause a payment to be made later than specified in this section unless interest is also paid. Payment of interest will be postponed when payment on the principal is delayed because of disagreement between the Owner and the Contractor.

Owner reserves the right, instead of requiring the Contractor to correct or resubmit a defective or improper application for payment, to reject the defective or improper portion of the application for payment and pay the remainder of the application for such amounts which are correct and proper.

Owner, upon written notice to the Contractor, may elect to make payments to the Contractor only by means of Electronic Funds Transfers (EFT) through Automated Clearing House (ACH) payments. If Owner makes this election, the Contractor shall arrange for receipt of the EFT/ACH payments.

E.2.2 Contractor shall submit to the Owner an application for each payment and, if required, receipts or other vouchers showing payments for materials and labor including payments to Subcontractors. Contractor shall include in its application for payment a schedule of the percentages of the various parts of the Work completed, based on the Schedule of Values which shall aggregate to the payment application total, and shall include, on the face of each copy thereof, a certificate in substantially the following form:

"I, the undersigned, hereby certify that the above bill is true and correct, and the payment therefore, has not been received.

Signed: _____
Dated: _____"

E.2.3 Generally, applications for payment will be accepted only for materials that have been installed. Under special conditions, applications for payment for stored materials will be accepted at Owner's sole discretion. Such a payment, if made, will be subject to the following conditions:

(a) The request for stored material shall be submitted at least thirty (30) Days in advance of the application for payment on which it appears. Applications for payment shall be entertained for major equipment, components or expenditures only.

(b) The Contractor shall submit applications for payment showing the quantity and cost of the material stored.

(c) The material shall be stored in a bonded warehouse and Owner shall be granted the right to access the material for the purpose of removal or inspection at any time during the Contract Period.

(d) The Contractor shall name the Owner as co-insured on the insurance policy covering the full value of the property while in the care and custody of the Contractor until it is installed. A certificate noting this coverage shall be issued to the Owner.

(e) Payments shall be made for materials and equipment only. The submitted amount in the application for payment shall be reduced by the cost of transportation from the storage site to the project site and for the cost of an inspector to verify delivery and condition of the goods at the storage site. The cost of storage and inspection shall be borne solely by the Contractor.

(f) Within sixty (60) Days of the application for payment, the Contractor shall submit evidence of payment covering the material and/or equipment stored and of payment for the storage site.

(g) Payment for stored materials and/or equipment shall in no way indicate acceptance of the materials and/or equipment or waive any rights under this Contract for the rejection of the Work or materials and/or equipment not in conformance with the Contract Documents.

(h) All required documentation shall be submitted with the respective application for payment.

E.2.4 The Owner reserves the right to withhold all or part of a payment, or may nullify in whole or part any payment previously made, to such extent as may be necessary in the Owner's opinion to protect the Owner from loss because of:

(a) Work that is defective and not remedied, or that has been demonstrated or identified as failing to conform with Applicable Laws or the Contract Documents,

(b) third party claims filed or evidence reasonably indicating that such claims will likely be filed unless security acceptable to the Owner is provided by the Contractor;

(c) failure of the Contractor to make payments properly to Subcontractors or for labor, materials or equipment (in which case Owner may issue checks made payable jointly to Contractor and such unpaid Persons under this provision, or directly to Subcontractors and suppliers at any level under Section C.3.2.1);

(d) reasonable evidence that the Work cannot be completed for the unpaid balance of the Contract Price;

(e) damage to the Work, Owner or another contractor;

(f) reasonable evidence that the Work will not be completed within the Contract Time required by the Contract, and that the unpaid balance would not be adequate to cover actual or liquidated damages for the anticipated delay;

(g) failure to carry out the Work in accordance with the Contract Documents; or

(h) assessment of liquidated damages, when withholding is made for offset purposes.

E.2.5 Subject to the provisions of the Contract Documents, the amount of each progress payment shall be computed as follows:

(a) Take that portion of the Contract Price properly allocable to completed Work as determined by multiplying the percentage completion of each portion of the Work by the share of the total Contract Price allocated to that portion of the Work in the Schedule of Values, less retainage as provided in Section E.5. Pending final determination of cost to the Owner of changes in the Work, no amounts for changes in the Work can be included in applications for payment until the Contract Price has been adjusted by a Supplement Amendment;

(b) Add that portion of the Contract Price properly allocable to materials and equipment delivered and suitably stored at the site for subsequent incorporation in the completed construction (or, if approved in advance by the Owner pursuant to Section E.2.3, suitably stored off the site at a location agreed upon in writing), less retainage as provided in Section E.5;

(c) Subtract the aggregate of previous payments made by the Owner; and

(d) Subtract any amounts for which the Owner has withheld or nullified payment as provided in the Contract Documents.

E.2.6 Contractor's applications for payment shall not include requests for payment for portions of the Work for which the Contractor does not intend to pay to a Subcontractor or material supplier.

E.2.7 The Contractor warrants to Owner that title to all Work covered by an application for payment will pass to the Owner no later than the time of payment. The Contractor further warrants that upon submittal of an application for payment all Work for which payments are received from the Owner shall be free and clear of liens, claims, security interests or encumbrances in favor of the Contractor, Subcontractors, material suppliers, or other persons or entities making a claim by reason of having provided financing, labor, materials and equipment relating to the Work.

E.2.8 If Contractor disputes any determination by Owner with regard to any application for payment, Contractor nevertheless shall continue to expeditiously perform the Work. No payment made hereunder shall be or be construed to be final acceptance or approval of that portion of the Work to which such partial payment relates or shall relieve Contractor of any of its obligations hereunder.

E.2.9 Contractor shall submit its initial MWESB Report within ten (10) Days of Contractor's execution of the Contract. Contractor shall submit annual MWESB Reports on June 30 of each year the Contract is active. Contracts - first executed by Contractor within ninety (90) Days before June 30 of the year of execution by Contractor may at the discretion of Owner be exempt from submitting the annual MWESB Report otherwise due on that June 30. The final MWESB Report shall be filed with the application for final payment. Timely receipt of MWESB Reports by Owner shall be a condition precedent to Owner's obligation to pay any progress payments or final payment otherwise due.

E.3 PAYROLL CERTIFICATION REQUIREMENT

Owner's receipt of payroll certification pursuant to Section C.2 of this Contract shall be a condition precedent to Owner's obligation to pay any progress payments or final payment otherwise due.

E.4 DUAL PAYMENT SOURCES

Contractor shall not be compensated for Work performed under this Contract from any state agency other than the agency that is a party to this Contract.

E.5 RETAINAGE

E.5.1 Retainage shall be withheld and released in accordance with the requirements set forth in OAR 580-063-0045.

E.5.1.1 Owner may reserve as retainage from any progress payment an amount not to exceed five percent of the payment. As Work progresses, Owner may reduce the amount of retainage on or may eliminate retainage on any remaining monthly Contract payments after 50 percent of the Work under the Contract is completed if, in the Owner's discretion, such Work is progressing satisfactorily. Elimination or reduction of retainage shall be allowed only upon written application by the Contractor, which application shall include written approval of Contractor's surety; except that when the Work is 97-1/2 percent completed the Owner may, at its discretion and without application by the Contractor, reduce the retained amount to 100 percent of the value of the Work remaining to be done. Upon receipt of written application by the

Contractor, Owner shall respond in writing within a reasonable time.

E.5.1.2 Contractor may request in writing:

- (a) to be paid amounts which would otherwise have been retained from progress payments where Contractor has deposited acceptable bonds and securities of equal value with Owner or in a custodial account or other mutually-agreed account satisfactory to Owner, with an approved bank or trust company to be held in lieu of the cash retainage for the benefit of Owner;
- (b) for construction projects over \$1,000,000, that retainage be deposited in an interest bearing account, established through the State Treasurer for state agencies, in a bank, savings bank, trust company or savings association for the benefit of Owner, with earnings from such account accruing to the Contractor; or
- (c) that the Owner allow Contractor to deposit a surety bond for the benefit of Owner, in a form acceptable to Owner, in lieu of all or a portion of funds retained, or to be retained. Such bond and any proceeds therefrom shall be made subject to all claims in the manner and priority as set forth for retainage.

When the Owner has accepted the Contractor's election of option (a) or (b), Owner may recover from Contractor any additional costs incurred through such election by reducing Contractor's final payment. Where the Owner has agreed to Contractor's request for option (c), Contractor shall accept like bonds from Subcontractors and suppliers on the project from which Contractor has required retainages.

E.5.1.3 The retainage held by Owner shall be included in and paid to the Contractor as part of the final payment of the Contract Price. The Owner shall pay to Contractor interest at the rate of two-thirds of one percent per month on the final payment due Contractor, interest to commence forty five (45) Days after the date which Owner receives Contractor's final approved application for payment and Work under the Contract has been completed and accepted and to run until the date when final payment is tendered to Contractor. The Contractor shall notify Owner in writing when the Contractor considers the Work complete and deliver to Owner its final application for payment and Owner shall, within fifteen (15) Days after receiving the written notice and the application for payment, either accept the Work or notify the Contractor of Work yet to be performed on the Contract. If Owner does not within the time allowed notify the Contractor of Work yet to be performed to fulfill contractual obligations, the interest provided by this subsection shall commence to run forty five (45) Days after the end of the 15-Day period.

E.5.1.4 Owner will reduce the amount of the retainage if the Contractor notifies the Owner that the Contractor has deposited in an escrow account with a bank or trust company, in a manner authorized by the Owner, bonds and securities of equal value of a kind approved by the Owner and such bonds and securities have in fact been deposited.

E.5.1.5 Contractor agrees that if Contractor elects to reserve a retainage from any progress payment due to any Subcontractor or supplier, such retainage shall not exceed five percent of the payment, and such retainage withheld from Subcontractors and suppliers shall be subject to the same terms and conditions stated in Subsection E.5 as apply to Owner's retainage from any progress payment due to Contractor.

E.6 FINAL PAYMENT

- E.6.1 Upon completion of all the Work under this Contract, the Contractor shall notify the Owner, in writing, that Contractor has completed Contractor's obligations under the Contract and shall prepare its application requesting final payment. Upon receipt of such notice and application for payment, the Owner will inspect the Work, and, if acceptable, submit to Contractor a recommendation as to acceptance of the completed Work and the final estimate of the amount due the Contractor. If the Work is not acceptable, Owner will notify Contractor within fifteen (15) Days of Contractor's request for final payment. Upon approval of this final application for payment by the Owner and compliance by the Contractor with provisions in Section K, and Contractor's satisfaction of other provisions of the Contract Documents as may be applicable, the Owner shall pay to the Contractor all monies due under the provisions of these Contract Documents.
- E.6.2 Neither final payment nor any remaining retained percentage shall become due until the Contractor submits to the Owner (1) a certificate evidencing that insurance required by the Contract Documents to remain in force after final payment is currently in effect and will not be canceled or allowed to expire until at least thirty (30) Days' prior written notice has been given to the Owner, (2) a written statement that the Contractor knows of no substantial reason that the insurance will not be renewable to cover the period required by the Contract Documents, (3) consent of surety, if any, to final payment and (4), if required by the Owner, other data establishing payment or satisfaction of obligations, such as receipts, releases and waivers of liens, claims, security interests or encumbrances arising out of the Contract, to the extent and in such form as may be designated by the Owner. If a Subcontractor refuses to furnish a release or waiver required by the Owner, the Contractor may furnish a bond satisfactory to the Owner to indemnify the Owner against such lien. If such lien remains unsatisfied after payments are made, the Contractor shall refund to the Owner all money that the Owner may be compelled to pay in discharging such lien, including all costs and reasonable attorneys' fees.
- E.6.3 Acceptance of final payment by the Contractor, a Subcontractor or material supplier shall constitute a waiver of claims by that payee except those previously made in writing and identified by that payee as unsettled at the time of final application for payment.
- E.6.4 Contractor agrees to submit its final payment application within ninety (90) Days after Substantial Completion, unless written extension is granted by Owner. Contractor shall not delay final payment application for any reason, including without limitation nonpayment of Subcontractors, suppliers, manufacturers or others not a party to this Contract, or lack of resolution of a dispute with Owner or any other person of matters arising out of or relating to the Contract. If Contractor fails to submit its final payment application within ninety (90) Days after Substantial Completion, and Contractor has not obtained written extension by Owner, all requests or Claims for additional costs or an extension of Contract Time shall be waived.

SECTION F JOB SITE CONDITIONS

F.1 USE OF PREMISES

Contractor shall confine equipment, storage of materials and operation of Work to the limits indicated by Contract Documents, Applicable Laws, permits or directions of the Owner. Contractor shall follow the Owner's instructions regarding use of premises, if any.

F.2 PROTECTION OF WORKERS, PROPERTY AND THE PUBLIC

- F.2.1 Contractor shall maintain continuous and adequate protection of all of the Work from damage and shall protect the Owner, workers and property from injury or loss arising in connection with this Contract. Contractor shall remedy acceptably to the Owner any damage, injury, or loss, except such as may be directly due to errors in the Contract Documents or caused by authorized representatives or personnel of the Owner. Contractor shall adequately protect adjacent property as provided by law and the Contract Documents.
- F.2.2 Contractor shall take all necessary precautions for the safety of all personnel on the job site or otherwise engaged in the undertaking of the Work and shall comply with the Contract Documents, best practices and all applicable provisions of federal, state and municipal safety laws and building and fire codes to prevent accidents or injury to persons on, about or adjacent to the premises where the Work is being performed. Contractor shall erect and properly maintain at all times, as required by the conditions and progress of the Work, all necessary safeguards for protection of workers and the public against any hazards created by construction. Contractor shall designate a responsible employee or associate on the Work site, whose duty shall be the prevention of accidents. The name and position of the person designated shall be reported to the Owner. The Owner has no responsibility for Work site safety. Work site safety shall be the responsibility of the Contractor.
- F.2.3 Contractor shall not enter upon private property without first obtaining permission from the property owner or its duly authorized representative. Contractor shall be responsible for the preservation of all public and private property along and adjacent to the Work contemplated under the Contract and shall use every precaution necessary to prevent damage thereto. In the event the Contractor damages any property, the Contractor shall at once notify the property owner and make, or arrange to make, full restitution. Contractor shall, immediately and in writing, report to the Owner, all pertinent facts relating to such property damage and the ultimate disposition of the claim for damage.
- F.2.4 Contractor shall be responsible for protection of adjacent work areas including impacts brought about by activities, equipment, labor, utilities, vehicles and materials on the site.
- F.2.5 Contractor shall at all times direct its activities in such a manner as to minimize adverse effects on the environment. Handling of all materials shall be conducted so no release will occur that may pollute or become hazardous.
- F.2.6 In an emergency affecting the safety of life or limb or of the Work or of adjoining property, the Contractor, without special instruction or authorization from the Owner, shall act reasonably to prevent threatened loss or injury, and shall so act, without appeal, if instructed by the Owner. Any compensation claimed by the Contractor on account of emergency work shall be determined in accordance with section D.

F.3 CUTTING AND PATCHING

- F.3.1 Contractor shall be responsible for coordinating all cutting, fitting, or patching of the Work to make its several parts come together properly and fit to receive or be received by work of other contractors or Subcontractors shown upon, or reasonably implied by, the Contract Documents.
- F.3.2 Contractor shall be responsible for restoring all cut, fitted, or patched surfaces to an original condition; provided, however, that if a different condition is specified in the Contract Documents, then Contractor shall be responsible for restoring such surfaces to the condition specified in the Contract Documents.

F.4 CLEANING UP

From time to time as may be prudent or ordered by the Owner and, in any event, immediately after completion of the Work, the Contractor shall, at its own expense, clean up and remove all refuse and unused materials of any kind resulting from the Work. If Contractor fails to do so within twenty-four hours after notification by the Owner the work may be done by others and the cost charged to the Contractor and deducted from payment due the Contractor.

F.5 ENVIRONMENTAL CONTAMINATION

F.5.1. Contractor shall be held responsible for and shall indemnify, defend (with counsel of Owner's choice), and hold harmless Owner from and against any costs, expenses, damages, claims, and causes of action, (including attorney fees), or any of them, resulting from all spills, releases, discharges, leaks and disposal of environmental pollution, including storage, transportation, and handling during the performance of the Work or Contractor's obligations under the Contract which occur as a result of, or are contributed by, the negligence or actions of Contractor or its personnel, agents, or Subcontractors or any failure to perform in accordance with the Contract Documents (except to the extent otherwise void under ORS 30.140). Nothing in this section F.5.1 shall limit Contractor's responsibility for obtaining insurance coverages required under Section G.3 of this Contract, and Contractor shall take no action that would void or impair such coverages.

F.5.1.1 Contractor agrees to promptly dispose of such spills, releases, discharge or leaks to the satisfaction of Owner and regulatory agencies having jurisdiction in a manner that complies with Applicable Laws. Cleanup shall be at no cost to the Owner and shall be performed by properly qualified and, if applicable, licensed personnel.

F.5.1.2 Contractor shall obtain the Owner's written consent prior to bringing onto the Work site any (i) environmental pollutants or (ii) hazardous substances or materials, as the same or reasonably similar terms are used in any Applicable Laws. Notwithstanding such written consent from the Owner, the Contractor, at all times, shall:

- (a) properly handle, use and dispose of all environmental pollutants and hazardous substances or materials brought onto the Work site, in accordance with all Applicable Laws;
- (b) be responsible for any and all spills, releases, discharges, or leaks of (or from) environmental pollutants or hazardous substances or materials which Contractor has brought onto the Work site; and
- (c) promptly clean up and remediate, without cost to the Owner, such spills, releases, discharges, or leaks to the Owner's satisfaction and in compliance with all Applicable Laws.

F.5.2 Contractor shall report all reportable quantity releases, as such releases are defined in Applicable Laws, including but not limited to 40 CFR Part 302, Table 302.4 and in OAR 340-142-0050, to applicable federal, state, and local regulatory and emergency response agencies. Upon discovery, regardless of quantity, Contractor must telephonically report all releases to the Owner. A written follow-up report shall be submitted to Owner within 48 hours of the telephonic report. Such written report shall contain, as a minimum:

- (a) Description of items released (identity, quantity, manifest numbers, and any and all other documentation required by law.)

- (b) Whether amount of items released is EPA/DEQ reportable, and, if so, when reported.
- (c) Exact time and location of release, including a description of the area involved.
- (d) Containment procedures initiated.
- (e) Summary of communications about the release between Contractor and members of the press or State, local or federal officials other than Owner.
- (f) Description of cleanup procedures employed or to be employed at the site, including disposal location of spill residue.
- (g) Personal injuries, if any, resulting from, or aggravated by, the release.

F.6 ENVIRONMENTAL CLEAN-UP

F.6.1 Unless disposition of environmental pollution is specifically a part of this Contract, or was caused by the Contractor (reference F.5 Environmental Contamination), Contractor shall immediately notify Owner of any hazardous substance(s) which Contractor discovers or encounters during performance of the Work required by this Contract. "Hazardous substance(s)" means any hazardous, toxic and radioactive materials and those substances defined as "hazardous substances," "hazardous materials," "hazardous wastes," "toxic substances," or other similar designations in any federal, state, or local law, regulation, or ordinance, including without limitation asbestos, polychlorinated biphenyl (PCB), or petroleum, and any substances, materials or wastes regulated by 40 CFR, Part 261 and defined as hazardous in 40 CFR S 261.3. In addition to notifying Owner of any hazardous substance(s) discovered or encountered, Contractor shall immediately cease working in any particular area of the project where a hazardous substance(s) has been discovered or encountered if continued work in such area would present a risk or danger to the health or well being of Contractor's or any Subcontractor's work force, property or the environment.

F.6.2 Upon being notified by Contractor of the presence of hazardous substance(s) on the project site, Owner shall arrange for the proper disposition of such hazardous substance(s).

F.7 FORCE MAJEURE

A party to this Contract shall not be held responsible for delay or default due to Force Majeure acts, events or occurrences unless they could have been avoided by the exercise of reasonable care, prudence, foresight, and diligence by that party. The Owner may terminate this Contract upon written notice after determining that delay or default caused by Force Majeure acts, events or occurrences will reasonably prevent successful performance of the Contract.

SECTION G *INDEMNITY, BONDING, AND INSURANCE*

G.1 RESPONSIBILITY FOR DAMAGES / INDEMNITY

G.1.1 Contractor shall be responsible for all damage to property, injury to persons, and loss, expense, inconvenience, and delay that may be caused by, or result from, the carrying out of the Work to be done under this Contract, or from any act, omission or neglect of the Contractor, its Subcontractors, employees, guests, visitors, invitees and agents.

G.1.2 To the fullest extent permitted by law, Contractor shall indemnify, defend (with counsel approved by Owner) and hold harmless the Owner, Architect/Engineer, Architect/Engineer's

consultants, and their respective officers, directors, agents, employees, partners, members, stockholders and affiliated companies (collectively "Indemnitees") from and against all liabilities, damages, losses, claims, expenses (including reasonable attorney fees), demands and actions of any nature whatsoever which arise out of, result from or are related to, (a) any damage, injury, loss, expense, inconvenience or delay described in this Section G.1., (b) any accident or occurrence which happens or is alleged to have happened in or about the project site or any place where the Work is being performed, or in the vicinity of either, at any time prior to the time the Work is fully completed in all respects, (c) any failure of the Contractor to observe or perform any duty or obligation under the Contract Documents which is to be observed or performed by the Contractor, or any breach of any agreement, representation or warranty of the Contractor contained in the Contract Documents or in any subcontract, (d) the negligent acts or omissions of the Contractor, a Subcontractor or anyone directly or indirectly employed by them or any one of them or anyone for whose acts they may be liable, regardless of whether or not such claim, damage, loss or expense is caused in part by a party indemnified hereunder (except to the extent otherwise void under ORS 30.140), and (e) any lien filed upon the project or bond claim in connection with the Work. Such obligation shall not be construed to negate, abridge, or reduce other rights or obligations of indemnity which would otherwise exist as to a party or person described in this Section G.1.2.

G.1.3 In claims against any person or entity indemnified under Section G.1.2 by an employee of the Contractor, a Subcontractor, anyone directly or indirectly employed by them or anyone for whose acts they may be liable, the indemnification obligation under Section G.1.2 shall not be limited by a limitation on amount or type of damages, compensation or benefits payable by or for the Contractor or a Subcontractor under workers' compensation acts, disability benefit acts or other employee benefit acts.

G.2 PERFORMANCE AND PAYMENT SECURITY; PUBLIC WORKS BOND

G.2.1 When the Contract Price is \$100,000 or more (or \$50,000 or more in the case of Contracts for highways, bridges and other transportation projects), the Contractor shall furnish and maintain in effect at all times during the Contract Period a performance bond in a sum equal to the Contract Price and a separate payment bond also in a sum equal to the Contract Price. Contractor shall furnish such bonds even if the Contract Price is less than the above thresholds if otherwise required by the Contract Documents.

G.2.2 Bond forms furnished by the Owner and notarized by awarded Contractor's surety company authorized to do business in Oregon are the only acceptable forms of performance and payment security, unless otherwise specified in the Contract Documents.

G.2.3 Before execution of the Contract the Contractor shall file with the Construction Contractors Board, and maintain in full force and effect, the separate public works bond required by Oregon Laws 2005, Chapter 360, and OAR 839-025-0015, unless otherwise exempt under those provisions. The Contractor shall also include in every subcontract a provision requiring the Subcontractor to have a public works bond filed with the Construction Contractors Board before starting Work, unless otherwise exempt, and shall verify that the Subcontractor has filed a public works bond before permitting any Subcontractor to start Work.

G.3 INSURANCE

G.3.1 Primary Coverage: Insurance carried by Contractor under this Contract shall be the primary coverage. The coverages indicated are minimums unless otherwise specified in the Contract Documents.

G.3.2 Workers' Compensation: All employers, including Contractor, that employ subject workers who work under this Contract in the State of Oregon shall comply with ORS 656.017 and provide the required Workers' Compensation coverage, unless such employers are exempt under ORS 656.126. This shall include Employer's Liability Insurance with coverage limits of not less than the minimum amount required by statute for each accident. Contractors who perform the Work without the assistance or labor of any employee need not obtain such coverage if the Contractor certifies so in writing. Contractor shall ensure that each of its Subcontractors complies with these requirements. The Contractor shall require proof of such Workers' Compensation coverage by receiving and keeping on file a certificate of insurance from each Subcontractor or anyone else directly employed by either the Contractor or its Subcontractors.

G.3.3 Builder's Risk Insurance:

G.3.3.1 Builder's Risk: During the term of this Contract, for new construction the Contractor shall obtain and keep in effect Builder's Risk insurance on an all risk forms, including earthquake and flood, for an amount equal to the full amount of the Contract, plus any changes in values due to modifications, Change Orders and loss of materials added. Such Builder's Risk shall include, in addition to earthquake and flood, theft, vandalism, mischief, collapse, transit, debris removal, and architect's fees ("soft costs") associated with delay of project due to insured peril. Any deductible shall not exceed \$50,000 for each loss, except the earthquake and flood deductible which shall not exceed 2 percent of each loss or \$50,000, whichever is greater. The deductible shall be paid by Contractor if Contractor is negligent. The policy will include as loss payees Owner, the Contractor and its Subcontractors as their interests may appear.

G.3.3.2 Builder's Risk Installation Floater: For Work other than new construction, Contractor shall obtain and keep in effect during the term of this Contract, a Builder's Risk Installation Floater for coverage of the Contractor's labor, materials and equipment to be used for completion of the Work performed under this Contract. The minimum amount of coverage to be carried shall be equal to the full amount of the Contract. The policy will include as loss payees Owner, the Contractor and its Subcontractors as their interests may appear. Owner may waive this requirement at its sole and absolute discretion.

G.3.3.3 Such insurance shall be maintained until Owner has occupied the facility.

G.3.3.4 A loss insured under the Builder's Risk insurance shall be adjusted by the Owner and made payable to the Owner as loss payee. The Contractor shall pay Subcontractors their just shares of insurance proceeds received by the Contractor, and by appropriate agreements, written where legally required for validity, shall require Subcontractors to make payments to their Sub-subcontractors in similar manner. The Owner shall have power to adjust and settle a loss with insurers.

G.3.4 General Liability Insurance:

G.3.4.1 Commercial General Liability: Upon issuance of a Supplement, Contractor shall obtain, and keep in effect at Contractor's expense for the term of the Supplement, Commercial General Liability Insurance covering bodily injury and property damage in the amount of \$1,000,000 per claim and \$2,000,000 per occurrence in a form satisfactory to Owner. This insurance shall include personal injury liability, products and completed operations, and contractual liability coverage for the

indemnities provided under this Contract (to the extent contractual liability coverage for the indemnity is available in the marketplace), and shall be issued on an occurrence basis.

- G.3.4.2 Automobile Liability: Contractor shall obtain, at Contractor's expense, and keep in effect during the term of this Contract, Automobile Liability Insurance covering owned, and/or hired vehicles, as applicable. The coverage may be written in combination with the Commercial General Liability Insurance. Contractor shall provide proof of insurance of not less than \$1,000,000 per claim and \$2,000,000 per occurrence. Contractor and its Subcontractors shall be responsible for ensuring that all non-owned vehicles maintain adequate Automobile Liability insurance while on site.
- G.3.4.3 Owner may adjust the insurance amounts required in Section G.3.4.1 and G.3.4.2 based upon institution specific risk assessments through the issuance of Supplemental General Conditions and a Supplement.
- G.3.4.4 "Tail" Coverage: If any of the required liability insurance is arranged on a "claims made" basis, "tail" coverage will be required at the completion of this Contract for a duration of 36 months or the maximum time period available in the marketplace if less than 36 months. Contractor shall furnish certification of "tail" coverage as described or continuous "claims made" liability coverage for 36 months following Final Completion. Continuous "claims made" coverage will be acceptable in lieu of "tail" coverage, provided its retroactive date is on or before the effective date of this Contract. Owner's receipt of the policy endorsement evidencing such coverage shall be a condition precedent to Owner's obligation to make final payment and to Owner's final acceptance of Work or services and related warranty (if any).
- G.3.4.5: Umbrella Liability (if required by Owner through issuance of Supplemental General Conditions): Contractor shall obtain, at Contractor's expense, and keep in effect during the term of this Contract, Umbrella liability Insurance over and above the general liability, automobile liability and workers' compensation coverage if required by Owner in specified limits at time of requirement.
- G.3.4.6 Pollution Liability (if required by Owner through issuance of Supplemental General Conditions): Contractor shall obtain, at Contractor's expense, and keep in effect during the term of this Contract, Pollution liability Insurance in minimum amounts of \$3,000,000 naming Owner as "additional insured," as noted in the "additional insured section below.
- G.3.5 Additional Insured: The general liability insurance coverage, professional liability, umbrella, and pollution liability if required, shall include the Owner as additional insureds but only with respect to the Contractor's activities to be performed under this Contract.
- If Contractor cannot obtain an insurer to name the Owner as additional insureds, Contractor shall obtain at Contractor's expense, and keep in effect during the term of this Contract, Owners and Contractors Protective Liability Insurance, naming the Owner as additional insureds with not less than a \$2,000,000 limit per occurrence. This policy must be kept in effect for 36 months following Final Completion. As evidence of coverage, Contractor shall furnish the actual policy to Owner prior to execution of the Contract.
- G.3.6 Notice of Cancellation or Change: If the Contractor receives a non-renewal or cancellation notice from an insurance carrier affording coverage required herein, or receives notice that coverage no longer complies with the insurance requirements herein, Contractor agrees to notify Owner by fax within five (5) business days with a copy of the non-renewal or cancellation notice, or written specifics as to which coverage is

no longer in compliance. When notified by Owner, the Contractor agrees to stop Work pursuant to this Contract, unless all required insurance remains in effect. Any failure to comply with the reporting provisions of this insurance, except for the potential exhaustion of aggregate limits, shall not affect the coverages provided to the Owner and its institutions, divisions, officers, and employees.

Owner shall have the right, but not the obligation, of prohibiting Contractor from entering the Work site until a new certificate(s) of insurance is provided to Owner evidencing the replacement coverage. The Contractor acknowledges and agrees that Owner reserves the right to withhold payment to Contractor until evidence of reinstated or replacement coverage is provided to Owner.

- G.3.7 Certificate(s) of Insurance: As evidence of the insurance coverage required by this Contract, the Contractor shall furnish certificate(s) of insurance to the Owner prior to execution of the Contract. The certificate(s) will specify all of the parties who are additional insureds or loss payees for this contract. Insurance coverage required under this Contract shall be obtained from insurance companies or entities acceptable to the Owner and that are eligible to provide such insurance under Oregon law. Eligible insurers include admitted insurers that have been issued a certificate of authority from the Oregon Department of Consumer and Business Services authorizing them to conduct an insurance business and issue policies of insurance in the state of Oregon, and certain non-admitted surplus lines insurers that satisfy the requirements of applicable Oregon law and which are subject to approval by the Owner. The Contractor shall be financially responsible for all deductibles, self-insured retentions and/or self-insurance included hereunder. Any deductible, self-insured retention and/or self-insurance in excess of \$50,000 shall be subject to approval by the Owner in writing and shall be a condition precedent to the effectiveness of any Supplement.
- G.3.8 Retainer Contract Program: For the OUS Retainer Contract Program the term "Contract" as used in this Section G in the phrases "keep in effect during the term of this Contract" and "prior to execution of the Contract" shall mean each Retainer Contract Supplement issued under the Retainer Contract.

SECTION H SCHEDULE OF WORK

H.1 CONTRACT PERIOD

- H.1.1 Time is of the essence. The Contractor shall at all times carry on the Work diligently, without delay and punctually fulfill all requirements herein. If required by the Contract Documents, Contractor shall commence Work on the site within fifteen (15) Days of Notice to Proceed, unless directed otherwise.
- H.1.2 Unless specifically extended by Supplement Amendment, all Work shall be complete by the date contained in the Contract Documents. The Owner shall have the right to accelerate the completion date of the Work, which may require the use of overtime. Such accelerated Work schedule shall be an acceleration in performance of Work under Section D.1.2 (f) and shall be subject to the provisions of Section D.1.
- H.1.3 The Owner shall not waive any rights under the Contract by permitting the Contractor to continue or complete in whole or in part the Work after the date described in Section H.1.2 above.

H.2 SCHEDULE

- H.2.1 Contractor shall provide, by or before the pre-construction conference, the initial as-planned schedule for review and acceptance by the Owner. The submitted schedule must illustrate Work by project components, with labor trades, and long lead items broken down by

building and/or floor where applicable. If Owner shall so elect, Contractor shall provide the schedule in CPM format showing the graphical network of planned activities, including i) a reasonably detailed list of all activities required to complete the Work; ii) the time and duration that each activity will take to completion; and iii) the dependencies between the activities. Schedules lacking adequate detail, or unreasonably detailed, will be rejected. The schedule shall include the following: Notice to Proceed or the date the Work commences, if no Notice to Proceed is issued by Owner, Substantial Completion, and Final Completion. Schedules shall be updated monthly, unless otherwise required by the Contract Documents, and submitted with the monthly application for payment. Acceptance of the Schedule by the Owner does not constitute agreement by the Owner as to the Contractor's sequencing, means, methods, or durations. Any positive difference between the Contractor's scheduled completion and the Contract completion date is float owned by the Owner. Owner reserves the right to negotiate the float if it is deemed to be in Owner's best interest to do so. In no case shall the Contractor make a claim for delays if the Work is completed within the Contract Time but after Contractor's scheduled completion. **H.3 PARTIAL OCCUPANCY OR USE**

H.3.1 The Owner may occupy or use any completed or partially completed portion of the Work at any stage, provided such occupancy or use is consented to by public authorities having jurisdiction over the Work. Such partial occupancy or use may commence whether or not the portion is substantially complete, provided the Owner and Contractor have reasonably accepted in writing the responsibilities assigned to each of them for payments, retainage, if any, security, insurance or self-insurance, maintenance, heat, utilities, and damage to the Work, and have agreed in writing concerning the period for correction of the Work and commencement of warranties required by the Contract Documents with respect to such portion of the Work. Approval by the Contractor to partial occupancy or use shall not be unreasonably withheld. Immediately prior to such partial occupancy or use, the Owner and Contractor shall jointly inspect the area to be occupied or portion of the Work to be used in order to determine and record the condition of the Work. Partial occupancy or use of a portion or portions of the Work shall not constitute acceptance of Work not complying with the requirements of the Contract Documents.

SECTION I CORRECTION OF WORK

I.1 CORRECTION OF WORK BEFORE FINAL PAYMENT

The Contractor warrants to the Owner that materials and equipment furnished under the Contract will be of good quality and new unless otherwise required or permitted by the Contract Documents, that the Work will be free from defects, and that the Work will conform to the requirements of the Contract Documents. Work failing to conform to these requirements shall be deemed defective. Contractor shall promptly remove from the premises and replace all defective materials and equipment as determined by the Owner, whether incorporated in the Work or not. Removal and replacement shall be without loss or expense to the Owner, and Contractor shall bear the cost of repairing all Work destroyed or damaged by such removal or replacement. Contractor shall be allowed a period of no longer than thirty (30) Days after Substantial Completion for completion of defective (Punch List) work. At the end of the thirty-day period, or earlier if requested by the Contractor, Owner shall arrange for inspection of the Work by the Architect/Engineer. Should the work not be complete, and all corrections made, the costs for all subsequent reinspections shall be borne by the Contractor. If Contractor fails to complete the Punch List work within the thirty (30) Day period, Owner may perform such work and Contractor shall reimburse Owner all costs of the same within ten (10) Days after demand without affecting Contractor's obligations.

I.2 WARRANTY WORK

I.2.1 Neither the final certificate of payment nor any provision of the Contract Documents shall relieve the Contractor from responsibility for defective Work and, unless a longer period is specified, Contractor shall correct all defects that appear in the Work within a period of one year from the date of issuance of the written notice of Substantial Completion by the Owner except for latent defects which will be remedied by the Contractor at any time they become apparent. The Owner shall give Contractor notice of defects with reasonable promptness. Contractor shall perform such warranty work within a reasonable time after Owner's demand. If Contractor fails to complete the warranty work within such period as Owner determines reasonable, or at any time in the event of warranty work consisting of emergency repairs, Owner may perform such work and Contractor shall reimburse Owner all costs of the same within ten (10) Days after demand, without affecting Contractor's obligations. The Contractor shall perform the warranty Work by correcting defects within twenty-four (24) hours of notification by Owner, unless otherwise specified in the Contract Documents. Should the Contractor fail to respond within the specified response time, the Owner may, at its option, complete the necessary repairs using another contractor or its own forces. If Owner completes the repairs using Owner's own forces, Contractor shall pay Owner at the rate of one and one-half (1½) times the standard hourly rate of Owner's forces, plus related overhead and any direct non-salary costs. If Owner completes the repairs using another contractor, Contractor shall pay Owner the amount of Owner's direct costs billed by the other contractor for the work, plus the direct salary costs and related overhead and direct non-salary expenses of Owner's forces who are required to monitor that contractor's work. Work performed by Owner using Owner's own forces or those of another contractor shall not affect the Contractor's contractual duties under these provisions, including warranty provisions.

I.2.2 Nothing in this Section I.2 shall negate guarantees or warranties for periods longer than one year including, without limitation, such guarantees or warranties required by other sections of the Contract Documents for specific installations, materials, processes, equipment or fixtures.

I.2.3 In addition to Contractor's warranty, manufacturer's warranties shall pass to the Owner and shall not take effect until such portion of the Work covered by the applicable warranty has been accepted in writing by the Owner.

I.2.4 The one-year period for correction of Work shall be extended with respect to portions of Work performed after Substantial Completion by the period of time between Substantial Completion and the actual performance of the Work, and shall be extended by corrective Work performed by the Contractor pursuant to this Section, as to the Work corrected. The Contractor shall remove from the site portions of the Work which are not in accordance with the requirements of the Contract Documents and are neither corrected by the Contractor nor accepted by the Owner.

I.2.5 Nothing contained in this Section I.2 shall be construed to establish a period of limitation with respect to other obligations which the Contractor might have under the Contract Documents. Establishment of the period for correction of Work as described in this Section I.2 relates only to the specific obligation of the Contractor to correct the Work, and has no relationship to the time within which the obligation to comply with the Contract Documents may be sought to be enforced, nor to the time within which proceedings may be commenced to establish the Contractor's liability with respect to the Contractor's obligations other than specifically to correct the Work.

I.2.6 If the Owner prefers to accept Work which is not in accordance with the requirements of the Contract Documents, the Owner may do so instead of requiring its removal and correction, in which case the Contract Price will be reduced as appropriate and

equitable. Such adjustment shall be effected whether or not final payment has been made.

estate fails to assume the Contract within a reasonable time;

SECTION J SUSPENSION AND/OR TERMINATION OF THE WORK

J.1 OWNER'S RIGHT TO SUSPEND THE WORK

J.1.1 The Owner has the authority to suspend portions or all of the Work due to the following causes:

- (a) Failure of the Contractor to correct unsafe conditions;
- (b) Failure of the Contractor to carry out any provision of the Contract;
- (c) Failure of the Contractor to carry out orders;
- (d) Conditions, in the opinion of the Owner, which are unsuitable for performing the Work;
- (e) Time required to investigate differing site conditions;
- (f) Any reason considered to be in the public interest.

J.1.2 The Owner shall notify Contractor and the Contractor's Surety in writing of the effective date and time of the suspension, and Owner shall notify Contractor and Contractor's surety in writing to resume Work.

J.2 CONTRACTOR'S RESPONSIBILITIES

J.2.1 During the period of the suspension, Contractor is responsible to continue maintenance at the project just as if the Work were in progress. This includes, but is not limited to, protection of completed Work, maintenance of access, protection of stored materials, temporary facilities, and clean-up.

J.2.2 When the Work is recommenced after the suspension, the Contractor shall replace or renew any Work damaged during the suspension, remove any materials or facilities used as part of temporary maintenance, and complete the Work in every respect as though its prosecution had been continuous and without suspension.

J.3 COMPENSATION FOR SUSPENSION

J.3.1 Depending on the reason for suspension of the Work, the Contractor or the Owner may be due compensation by the other party. If the suspension was required due to acts or omissions of Contractor, the Owner may assess the Contractor actual costs of the suspension in terms of administration, remedial work by the Owner's forces or another contractor to correct the problem associated with the suspension, rent of temporary facilities, and other actual costs related to the suspension. If the suspension was caused by acts or omissions of the Owner, the Contractor may be due compensation which shall be defined using Section D, Changes in Work. If the suspension was required through no fault of the Contractor or the Owner, neither party shall owe the other for the impact.

J.4 OWNER'S RIGHT TO TERMINATE CONTRACT

J.4.1 The Owner may, without prejudice to any other right or remedy, and after giving Contractor seven (7) Days' written notice and an opportunity to cure, terminate the Contract in whole or in part under the following conditions:

- (a) If Contractor should, voluntarily or involuntarily, seek protection under the United States Bankruptcy Code and Contractor as debtor-in-possession or the Trustee for the

(b) If Contractor should make a general assignment for the benefit of Contractor's creditors;

(c) If a receiver should be appointed on account of Contractor's insolvency;

(d) If Contractor should repeatedly refuse or fail to supply an adequate number of skilled workers or proper materials to carry on the Work as required by the Contract Documents, or otherwise fail to perform the Work in a timely manner;

(e) If Contractor should repeatedly fail to make prompt payment to Subcontractors or for material or labor, or should disregard laws, ordinances or the instructions of the Owner; or

(f) If Contractor is otherwise in breach of any part of the Contract.

(g) If Contractor is in violation of Applicable Laws, either in the conduct of its business or in its performance of the Work.

J.4.2 At any time that any of the above occurs, Owner may exercise all rights and remedies available to Owner at law or in equity, and, in addition, Owner may take possession of the premises and of all materials and appliances and finish the Work by whatever method it may deem expedient. In such case, the Contractor shall not be entitled to receive further payment until the Work is completed. If the Owner's cost of finishing the Work exceeds the unpaid balance of the Contract Price, Contractor shall pay the difference to the Owner.

J.5 TERMINATION FOR CONVENIENCE

J.5.1 Owner may terminate the Contract in whole or in part whenever Owner determines that termination of the Contract is in the best interest of Owner or the public.

J.5.2 The Owner shall provide the Contractor with seven (7) Days prior written notice of a termination for Owner's or for public convenience. After such notice, the Contractor shall provide the Owner with immediate and peaceful possession of the premises and materials located on and off the premises for which the Contractor received progress payment under Section E. Compensation for Work terminated by the Owner under this provision will be according to Section E. In no circumstance shall Contractor be entitled to lost profits for Work not performed due to termination.

J.6 ACTION UPON TERMINATION

J.6.1 Upon receiving a notice of termination, and except as directed otherwise by the Owner, Contractor shall immediately cease placing further subcontracts or orders for materials, services, or facilities. In addition, Contractor shall terminate all subcontracts or orders to the extent they relate to the Work terminated and, with the prior written approval of the Owner, settle all outstanding liabilities and termination settlement proposals arising from the termination of subcontracts and orders.

J.6.2 As directed by the Owner, Contractor shall, upon termination, transfer title and deliver to the Owner all Record Documents, information, and other property that, if the Contract had been completed, would have been required to be furnished to the Owner.

J.6.3 Upon Owner's notice of termination pursuant to either Section J.4 or J.5, if Owner shall so elect, Contractor shall assign to the Owner such subcontracts and orders as Owner shall specify. In

the event Owner elects to take assignment of any such subcontract or order, Contractor shall take such action and shall execute such documents as Owner shall reasonably require for the effectiveness of such assignment and Contractor shall ensure that no contractual arrangement between it and its subcontractors or suppliers of any tier or sub-tier shall prevent such assignment.

SECTION K **CONTRACT CLOSE OUT**

K.1 RECORD DOCUMENTS

As a condition of final payment (and subject to the provisions of section E.6), Contractor shall comply with the following: Contractor shall provide Record Documents for the entire project to Owner. Record Documents shall depict the project as constructed and shall reflect each and every change, modification, and deletion made during the construction. Record Documents are part of the Work and shall be provided prior to the Owner's issuance of final payment. Record Documents include all modifications to the Contract Documents, unless otherwise directed, and accurate MWESB Reports.

K.2 OPERATION AND MAINTENANCE MANUALS

As part of the Work, Contractor shall submit two completed operation and maintenance manuals ("O & M Manuals") for review by the Owner prior to submission of any pay request for more than 75% of the Work. Owner's receipt of the O & M Manuals shall be a condition precedent to any payment thereafter due. The O & M Manuals shall contain a complete set of all submittals, all product data as required by the specifications, training information, telephone list and contact information for all consultants, manufacturers, installer and suppliers, manufacturer's printed data, record and shop drawings, schematic diagrams of systems, appropriate equipment indices, warranties and bonds. The Owner shall review and return one O & M Manual for any modifications or adjustments required. Prior to submission of its final pay request, Contractor shall deliver three (3) complete and approved sets of O & M Manuals to the Owner and Owner's receipt of the O & M Manuals shall be a condition precedent to Owner's obligation to make final payment.

K.3 COMPLETION NOTICES

- K.3.1 Contractor shall provide Owner written notice of both Substantial and Final Completion. The certificate of Substantial Completion shall state the date of Substantial Completion, the responsibilities of the Owner and Contractor for security, maintenance, heat, utilities, damage to the Work and insurance, and the time within which the Contractor shall finish all items on the Punch List accompanying the Certificate. Both completion notices must be signed by the Contractor and the Owner to be valid. The Owner shall provide the final signature on the approved notices. The notices shall take effect on the date they are signed by the Owner.
- K.3.2 Substantial Completion of a facility with operating systems (e.g., mechanical, electrical, HVAC) shall be that degree of completion that has provided a minimum of thirty (30) continuous Days of successful, trouble-free operation, which period shall begin after all performance and acceptance testing has been successfully demonstrated to the Owner. All equipment contained in the Work, plus all other components necessary to enable the Owner to operate the facility in the manner that was intended, shall be complete on the Substantial Completion date. The Contractor may request that a Punch List be prepared by the Owner with submission of the request for the Substantial Completion notice.

K.4 TRAINING

As part of the Work, and prior to submission of the final application for payment, the Contractor shall schedule with the Owner training sessions for all equipment and systems as required by the

Contract Documents. Contractor shall schedule training sessions at least two weeks in advance of the date of training to allow Owner to provide its personnel with adequate notice. The O & M Manual shall be used as a basis for training. Training shall be a formal session conducted at the Work site after the equipment and/or system is completely installed and operational in its normal operating environment.

K.5 EXTRA MATERIALS

As part of the Work, Contractor shall provide spare parts, extra maintenance materials, and other materials or products in the quantities specified in the Contract Documents prior to final payment. Delivery point for extra materials shall be designated by the Owner.

K.6 ENVIRONMENTAL CLEAN-UP

As part of the Final Completion notice, or as a separate written notice submitted with or before the notice of Final Completion, the Contractor shall notify the Owner that all environmental and pollution clean-up, remediation and closure have been completed in accordance with all Applicable Laws and pursuant to the authority of all agencies having jurisdiction, and Contractor shall provide Owner with any and all documentation related to the same, including but not limited to directives, orders, letters, certificates and permits related to or arising from such environmental pollution. The notice shall reaffirm the indemnification given under Section F.5.1 above. Contractor's completion of its obligations under this Section K.6 and Owner's receipt of documents evidencing such completion shall be a condition precedent to Owner's obligation to make final payment.

K.7 CERTIFICATE OF OCCUPANCY

Owner's receipt of an unconditioned certificate of occupancy from the appropriate state and/or local building officials shall be a condition precedent to Owner's obligation to make final payment, except to the extent failure to obtain an unconditional certificate of occupancy is due to the fault or neglect of Owner.

K.8 OTHER CONTRACTOR RESPONSIBILITIES

The Contractor shall be responsible for returning to the Owner all property of Owner issued to Contractor during construction such as keys, security passes, site admittance badges, and all other pertinent items. Upon notice from Owner, Contractor shall be responsible for notifying the appropriate utility companies to transfer utility charges from the Contractor to the Owner. The utility transfer date shall not be before Substantial Completion and may not be until Final Completion, if the Owner does not take beneficial use of the facility and the Contractor's forces continue with the Work.

K.9 SURVIVAL

All warranty and indemnification provisions of this Contract, and all of Contractor's other obligations under this Contract that are not fully performed by the time of Final Completion or termination, shall survive Final Completion or any termination of the Contract.

OREGON UNIVERSITY SYSTEM
STANDARD PUBLIC IMPROVEMENT CONTRACT
PERFORMANCE BOND

Bond No. _____
 Solicitation _____
 Project Name _____

_____	(Surety #1)	Bond Amount No. 1:	\$ _____
_____	(Surety #2)*	Bond Amount No. 2:*	\$ _____
* If using multiple sureties		Total	Penal Sum of Bond: \$ _____

We, _____ as Principal, and the above identified Surety(ies), authorized to transact surety business in Oregon, as Surety, hereby jointly and severally bind ourselves, our respective heirs, executors, administrators, successors and assigns firmly by these presents to pay unto the State of Oregon, acting by and through the State Board of Higher Education, on behalf of the OUS (OUS), the sum of (Total Penal Sum of Bond)

_____ (Provided, that we the Sureties bind ourselves in such sum “jointly and severally” as well as “severally” only for the purpose of allowing a joint action or actions against any or all of us, and for all other purposes each Surety binds itself, jointly and severally with the Principal, for the payment of such sum only as is set forth opposite the name of such Surety), and

WHEREAS, the Principal has entered into a contract with the OUS, the plans, specifications, terms and conditions of which are contained in the above-referenced Solicitation;

WHEREAS, the terms and conditions of the contract, together with applicable plans, standard specifications, special provisions, schedule of performance, and schedule of contract prices, are made a part of this Performance Bond by reference, whether or not attached to the contract (all hereafter called “Contract”); and

WHEREAS, the Principal has agreed to perform the Contract in accordance with the terms, conditions, requirements, plans and specifications, and all authorized modifications of the Contract which increase the amount of the work, the amount of the Contract, or constitute an authorized extension of the time for performance, notice of any such modifications hereby being waived by the Surety:

NOW, THEREFORE, THE CONDITION OF THIS BOND IS SUCH that if the Principal herein shall faithfully and truly observe and comply with the terms, conditions and provisions of the Contract, in all respects, and shall well and truly and fully do and perform all matters and things undertaken by Contractor to be performed under the Contract, upon the terms set forth therein,

and within the time prescribed therein, or as extended as provided in the Contract, with or without notice to the Sureties, and shall indemnify and save harmless the OUS, and _____ (name of institution and any other Owner agency), and members thereof, its officers, employees and agents, against any direct or indirect damages or claim of every kind and description that shall be suffered or claimed to be suffered in connection with or arising out of the performance of the Contract by the Principal or its subcontractors, and shall in all respects perform said contract according to law, then this obligation is to be void; otherwise, it shall remain in full force and effect.

Nonpayment of the bond premium will not invalidate this bond, nor shall the State of Oregon or the OUS, be obligated for the payment of any premiums.

This bond is given and received under authority of ORS Chapters 279C and 351, the provisions of which hereby are incorporated into this bond and made a part hereof.

IN WITNESS WHEREOF, WE HAVE CAUSED THIS INSTRUMENT TO BE EXECUTED AND SEALED BY OUR DULY AUTHORIZED LEGAL REPRESENTATIVES.

Dated this _____ day of _____, 20__.

PRINCIPAL: _____

By _____

Signature

Official Capacity

Attest:

Corporation Secretary

SURETY: _____

[Add signatures for each surety if using multiple bonds]

BY ATTORNEY-IN-FACT:

[Power-of-Attorney must accompany each surety bond]

Name

Signature

Address

City

State

Zip

Phone

Fax

OREGON UNIVERSITY SYSTEM

STANDARD PUBLIC IMPROVEMENT CONTRACT

PAYMENT BOND

Bond No. _____
Solicitation _____
Project Name _____

_____ (Surety #1) Bond Amount No. 1: \$ _____
_____ (Surety #2)* Bond Amount No. 2:* \$ _____
** If using multiple sureties* Total Penal Sum of Bond: \$ _____

We, _____, as Principal, and the above identified Surety(ies), authorized to transact surety business in Oregon, as Surety, hereby jointly and severally bind ourselves, our respective heirs, executors, administrators, successors and assigns firmly by these presents to pay unto the State of Oregon, acting by and through the State Board of Higher education, on behalf of the Oregon University System (OUS), the sum of (Total Penal Sum of Bond) _____ (Provided, that we the Sureties bind ourselves in such sum "jointly and severally" as well as "severally" only for the purpose of allowing a joint action or actions against any or all of us, and for all other purposes each Surety binds itself, jointly and severally with the Principal, for the payment of such sum only as is set forth opposite the name of such Surety), and

WHEREAS, the Principal has entered into a contract with the OUS, the plans, specifications, terms and conditions of which are contained in above-referenced Solicitation;

WHEREAS, the terms and conditions of the contract, together with applicable plans, standard specifications, special provisions, schedule of performance, and schedule of contract prices, are made a part of this Payment Bond by reference, whether or not attached to the contract (all hereafter called "Contract"); and

WHEREAS, the Principal has agreed to perform the Contract in accordance with the terms, conditions, requirements, plans and specifications, and schedule of contract prices which are set forth in the Contract and any attachments, and all authorized modifications of the Contract which increase the amount of the work, or the cost of the Contract, or constitute authorized extensions of time for performance of the Contract, notice of any such modifications hereby being waived by the Surety:

NOW, THEREFORE, THE CONDITION OF THIS BOND IS SUCH that if the Principal shall faithfully and truly observe and comply with the terms, conditions and provisions of the Contract, in all respects, and shall well and truly and fully do and perform all matters and things by it undertaken to be performed under said Contract and any duly authorized modifications that are made, upon the terms set forth therein, and within the time prescribed therein, or as extended therein as provided in the Contract, with or without notice to the Sureties, and shall indemnify and save harmless the OUS and _____ (name of institution and any other Owner agency), and members thereof, its officers, employees and agents, against any claim for direct or indirect damages of every kind and description that shall be suffered or

claimed to be suffered in connection with or arising out of the performance of the Contract by the Contractor or its subcontractors, and shall promptly pay all persons supplying labor, materials or both to the Principal or its subcontractors for prosecution of the work provided in the Contract; and shall promptly pay all contributions due the State Industrial Accident Fund and the State Unemployment Compensation Fund from the Principal or its subcontractors in connection with the performance of the Contract; and shall pay over to the Oregon Department of Revenue all sums required to be deducted and retained from the wages of employees of the Principal and its subcontractors pursuant to ORS 316.167, and shall permit no lien nor claim to be filed or prosecuted against the State on account of any labor or materials furnished; and shall do all things required of the Principal by the laws of this State, then this obligation shall be void; otherwise, it shall remain in full force and effect.

Nonpayment of the bond premium will not invalidate this bond, nor shall the State of Oregon, or the OUS be obligated for the payment of any premiums.

This bond is given and received under authority of ORS Chapters 279C and 351, the provisions of which hereby are incorporated into this bond and made a part hereof.

IN WITNESS WHEREOF, WE HAVE CAUSED THIS INSTRUMENT TO BE EXECUTED AND SEALED BY OUR DULY AUTHORIZED LEGAL REPRESENTATIVES:

Dated this _____ day of _____, 20__.

PRINCIPAL: _____

By _____
Signature

Official Capacity
Attest: _____
Corporation Secretary

SURETY: _____
[Add signatures for each if using multiple bonds]

BY _____
ATTORNEY-IN-FACT:
[Power-of-Attorney must accompany each bond]

Name

Signature

Address

City State Zip

Phone Fax

**RETAINER CONTRACT SUPPLEMENT
OUS RETAINER CONTRACT FOR CONSTRUCTION
RELATED SERVICES**

Supplement No.
Project Name
Owner's Project
Manager

This Retainer Contract Supplement dated _____ (the "Supplement") is entered into between:

"Contractor":

Federal Tax ID No.

and "Owner":

The State of Oregon, acting by and through the State
Board of Higher Education, on behalf of:

(collectively, the "Parties") pursuant to the Retainer Contract for Construction Related Services between the Parties terminating June 30, 2014 (the "Retainer Contract"). Capitalized terms have the meaning defined in the OUS Retainer General Conditions unless otherwise defined in the Retainer Contract or herein.

1. DESCRIPTION OF THE PROJECT. The project to which this Supplement pertains is described as follows: _____ (the "Project").

2. WORK TO BE PERFORMED. Contractor shall perform the following work on the Project : _____ (the "Work"). Contractor will perform the Work according to the terms and conditions of this Supplement and the Contract Documents, which are incorporated herein by this reference.

3. SCHEDULE. Contractor shall perform the Work according to the following schedule: _____ (the "Schedule").

4. COMPENSATION. Owner shall compensate Contractor for Work (a) in the firm, fixed-price amount of \$ _____; or (b) on a time and materials basis subject to a maximum not-to-exceed price of \$ _____; in accordance with the requirements of the OUS Retainer General Conditions. If the Work is performed on a time and materials basis, Contractor's listing of wage rates, material unit costs and overhead charges for the Work is attached to this Supplement.

The cost of the Work under this Supplement, even if this Supplement is later amended to include additional work, must not exceed the greater of \$1,000,000 or the maximum allowable under

OAR 580-063-0030.

5. TERM. This Supplement is effective on the date it has been signed by every Party hereto and all approvals required by Applicable Law have been obtained (the “Effective Date”). No Work shall be performed or payment made prior to the Effective Date. Contractor shall perform its obligations in accordance with the Contract Documents, unless this Supplement is earlier terminated or suspended.

6. PERFORMANCE AND PAYMENT BONDS. The performance and payment bond requirements for this Project are as follows (check one of the following):

As a condition precedent to the effectiveness of this Supplement and to Owner’s obligation to make payment for the Work, Contractor shall provide the Owner with a performance bond and a separate payment bond in a sum equal to the Contract Price stated in Section 4 of this Supplement.

This Project has a Contract price of \$100,000 or less, and Owner has determined that performance and payment bonds will not be required for this Project.

7. MINIMUM WAGE RATES.

Prevailing Wage Rates requirements do not apply to this Project because the maximum compensation for all Owner-contracted Work does not exceed \$50,000.

Prevailing Wage Rates requirements apply to this Project because the maximum compensation for all Owner-contracted Work is more than \$50,000. Contractor and all subcontractors shall comply with the provisions of ORS 279C.800 through 279C.870, relative to Prevailing Wage Rates and the required public works bond, as outlined in Sections C.1, C.2 and G.2.3 of the OUS Retainer General Conditions. The Bureau of Labor and Industries (BOLI) wage rates and requirements set forth in the following BOLI booklet (and any listed amendments to that booklet), which are incorporated herein by reference, apply to the Work authorized under this Supplement:

PREVAILING WAGE RATES for Public Works Contracts in Oregon, _____, 20____, as amended _____, 20____ [delete “as amended _____, 20____” if there have been no amendments since last rate change], which can be downloaded at the following web address:

[http://www.boli.state.or.us/BOLI/WHD/PWR/pwr_book.shtml]

The Work will take place in _____ County, Oregon.

8. TAX COMPLIANCE CERTIFICATION. Contractor hereby certifies and affirms, under penalty of perjury as provided in ORS 305.385(6), that, to the best of Contractor’s knowledge, Contractor is not in violation of any of the tax laws described in ORS 305.380(4). For purposes of this certification, “tax laws” means a state tax imposed by ORS 320.005 to 320.150 and 403.200 to 403.250, ORS Chapters 118, 314, 316, 317, 318, 321 and 323; the elderly rental assistance program under ORS 310.630 to 310.706; and local taxes administered by the Oregon Department of Revenue under ORS 305.620.

9. INSURANCE REQUIREMENTS.

Contractor shall comply with and obtain the insurance coverage amounts stated in the OUS Retainer General Conditions.

The Owner has determined that the Contractor shall obtain insurance in the amount described in the Retainer Supplemental General Conditions, attached hereto.

10. KEY PERSONS. If checked here, the following provision is incorporated into this Supplement:

The Parties agree that certain Contractor personnel are specifically valuable to the Project (“Key Persons”). Key Persons shall not be replaced during the Project without the written consent of Owner, which shall not be unreasonably withheld. If Contractor intends to substitute personnel, Owner shall receive the request at least 15 days prior to the effective date of substitution. When replacements have been approved by Owner, Contractor shall provide a transition period of at least 10 working days during which the original and replacement personnel shall be working on the Project concurrently. Upon authorization for the replacement of a Key Person, all subsequent substitutions of that Key Person shall require Owner’s written consent in accordance with this Section. The Key Persons for this Project are the following:

Project Executive: _____ shall be Contractor’s Project Executive, and will provide oversight and guidance throughout the Project term.

Project Manager: _____ shall be Contractor’s Project Manager and will participate in all meetings throughout the Project term.

Job Superintendent: _____ shall be Contractor’s on-site Job Superintendent throughout the Project term.

Project Engineer: _____ shall be Contractor’s Project Engineer, providing assistance to the Project Manager, and subcontractor and supplier coordination throughout the Project term.

11. OTHER TERMS. Except as specifically modified by this Supplement, all terms of the Retainer Contract remain unchanged.

12. EXECUTION AND COUNTERPARTS. This Supplement may be executed in several counterparts, each of which shall be an original, all of which shall constitute but one and the same instrument.

Contractor hereby confirms and certifies that the representations, warranties, and certifications contained in the Retainer Contract remain true and correct as of the Effective Date of this Supplement.

IN WITNESS HEREOF, the Parties have duly executed this Supplement as of the dates indicated below.

_____, Contractor

The State of Oregon, acting by and through

the State Board of Higher Education, on
behalf of _____, Owner

By: _____

By: _____

Title: _____

Title: _____

Date: _____

Date: _____

**RETAINER CONTRACT SUPPLEMENT AMENDMENT
OUS RETAINER CONTRACT FOR CONSTRUCTION
RELATED SERVICES**

Supplement No.:
Amendment No.:
Project Name:

This Amendment dated _____ to the Retainer Contract Supplement is entered into between:

“Contractor”:

Federal Tax ID No.

and “Owner”:
The State of Oregon, acting by and through the State
Board of Higher Education, on behalf of:

(collectively the “Parties”) pursuant to the Retainer Contract for Construction Related Services between the Parties expiring June 30, 2014 (the “Retainer Contract”). Capitalized terms have the meaning defined in the OUS Retainer General Conditions unless otherwise defined in the Contract Documents.

1. SERVICES: The Work described in the Retainer Contract Supplement is being amended as follows:

2. SCHEDULE. The schedule contained in Section 3 of the Retainer Contract Supplement is hereby replaced in its entirety with the following schedule:

3. COMPENSATION. Section 4 of the Retainer Contract Supplement, is hereby replaced in its entirety with the following:

“Owner will compensate Contractor for Work (a) in the firm, fixed-price amount of \$ _____ ; or (b) on a time and materials basis subject to a maximum not-to-exceed price of \$ _____ ; in accordance with the requirements of the OUS Retainer General Conditions. If the Project is done on a time and materials basis, Contractor’s listing of wage rates, material unit costs and overhead charges for the Work is attached to this Supplement.

The total cost of Work including the original amount contemplated in the Supplement and the additional amount contemplated in this Amendment, must not exceed the greater of \$1,000,000 or the maximum allowable under OAR 580-063-0030.”

4. TERM. This Amendment is effective on the date it has been executed by the Parties and all required approvals have been obtained (the "Effective Date"). No Work will be performed or payment made prior to the Effective Date.

5. TAX COMPLIANCE CERTIFICATION. Contractor hereby certifies and affirms, under penalty of perjury as provided in ORS 305.385(6), that, to the best of Contractor's knowledge, Contractor is not in violation of any of the tax laws described in ORS 305.380(4). For purposes of this certification, "tax laws" means a state tax imposed by ORS 320.005 to 320.150 and 403.200 to 403.250, ORS Chapters 118, 314, 316, 317, 318, 321 and 323; the elderly rental assistance program under ORS 310.630 to 310.706; and local taxes administered by the Oregon Department of Revenue under ORS 305.620.

6. EXECUTION AND COUNTERPARTS. This Amendment may be executed in several counterparts, each of which shall be an original, all of which shall constitute but one and the same instrument.

Contractor hereby confirms and certifies that the representations, warranties and certifications contained in the Retainer Contract and the Retainer Contract Supplement remain true and correct as of the Effective Date of this Amendment.

IN WITNESS HEREOF, the Parties have duly executed this Amendment as of the dates indicated below.

_____, Contractor

The State of Oregon, acting by and through
the State Board of Higher Education, on
behalf of _____, Owner

By: _____

By: _____

Title: _____

Title: _____

Date: _____

Date: _____

PREVAILING WAGE RATES

for

Public Works Contracts in Oregon



OREGON BUREAU OF LABOR AND INDUSTRIES

**Brad Avakian
Commissioner
Bureau of Labor and Industries**

Effective: July 1, 2012

http://www.oregon.gov/boli/WHD/PWR/Pages/July2012_Index.aspx

CapCon MWESB Subcontractor Report

REPORT BEING SUBMITTED	
-------------------------------	--

OVERALL PROJECT DATA

Reporting Period	2011
Campus	
General Contractor's Name	
Contract Number	
Project Name	
Contract Execution Date (Date Contract was Signed by the Owner)	
Date of Final Payment Application	
Initial Total Contract Value	
Total Contract Value billed within the fiscal year (July 1 - June 30)	
Final Total Contract Value	
Total Number of Subcontractors Used on Project	
Total Number of First-Tier Subcontractors Used on Project	
Number of First-Tier MWESB Subcontractors	

CALCULATED REPORTING DATA (Self Calculating - No Data Entry)

Number of MWESB Subcontractors	0
% MWESB Subcontractors	
% First-Tier MWESB Subcontractors	
CERTIFIED MWESB TOTALS	
Value Awarded to MWESB Contractors	\$0.00
% Value Awarded to MWESB Contractors	
Value - minority-owned MWESB subcontractors	\$0.00
% - minority-owned MWESB subcontractors	
Value - women-owned MWESB subcontractors	\$0.00
% - women-owned MWESB subcontractors	
Value - emerging small business MWESB subcontractors	\$0.00
% - emerging small business MWESB subcontractors	
SELF-IDENTIFIED or OTHER CERTIFIED MWESB TOTALS	
Value - self-identified or other certified subcontractors	\$0.00
% - self-identified or other certified subcontractors	
OVERALL PROJECT CONTRACT HISTORY	
% Value Awarded to MWESB Contractors at Initial Contract	#DIV/0!
% Value Awarded to MWESB Contractors at Final Contract	#DIV/0!
FOR OFFICIAL USE ONLY:	
Date Received by the Campus	
Initials of Campus staff who checked the document	

Created: September 15, 2011/Updated 4/3/12

Purpose of File:

Each Fiscal year, the OUS campuses are required to report data to the State Legislature on Minority, Women and Emerging Small Business Contractors and Sub-Contractors who provide goods and services. Various statistics are calculated, based on the data input being provided by the contractors. This is for the collection of the data for each project by contract. Each University will compile statistics associated with all of their contracts during each fiscal year. Once consolidated at the University level, the information is sent to OUS who in turn consolidates all of the information from the seven institutions and reports it to the Legislature.

General Information on how to use the file:

You will fill this form out at least twice for your project. Small projects that do NOT span over the end of a fiscal year (June 30 – July 1) will require two submittals (An Initial and a Final). Any project spanning over the end of a fiscal year will require three submittals (Initial, Year-End and Final). For larger projects that span over multiple fiscal years, the Year-End report will need to be submitted multiple times.

The first Submittal will always be the “Initial” report which is due within 10 days of the execution of the contract or in the case of a CM/GC contract, the establishment of an Early Work Amendment or Guaranteed Maximum Price Amendment.

At the end of every fiscal year, you are required to submit a “Year-End” report.

At the completion of the project you are required to submit a “Final” report.

- 2) The areas shaded in gray in the OVERALL PROJECT DATA section are for input by the Contractor. The gray portion of the “Individual Contractor/Sub-Contractor Data Entry Matrix” is also an area intended for Contractor input.
- 3) For some items, a drop-down box is provided. This is to maintain the consistency of data used to sort information.
- 4) For other items, simply type in the information. If the type of information typed in is incorrect, you will get an error message or your results may look incorrect. For example, when you enter a date, simply type it: 8/17/11. You do not need to spell out the month.

Saving your file:

- 1) FILE NAMING CONVENTION – All files submitted to the campus shall be named as defined by the following naming convention: (filename = FYXX_ContractNumber_SubmissionStatus)

FYXX = XX refers to the two digit extension of the year. Example “FY12” for Fiscal Year 2012.

Include an underscore between the FYXX and the Contract Number. There should be no blanks in the filename.

ContractNumber = Insert the number that is established on the front of your contract with the campus.

Include an underscore between the Contract Number and the Submission Status. There should be no blanks in the filename.2)

SubmissionStatus = ”I” for Initial; “Y” for Year end; “F” for Final. This should correspond with what you select at the top of the report as explained in item 1 of “Filling Out the Form” below.

Filling Out the Form:

- 1) Use the drop-down box adjacent to the REPORT BEING SUBMITTED heading to pick the corresponding report you are submitting for your project. This will establish highlighted headings (in light green) in the “Individual C/S-C Data Entry Matrix” & OPERALL PROJECT DATA sections that define for you which columns or rows should be completely filled out prior to submission.

- 2) Next, fill in the information in the OVERALL PROJECT DATA section. Again, rows highlighted in green will tell you which cells to fill in based upon the type of report being submitted. Only fill in the cells that are highlighted. The top 5 cells should remain the same for the duration of the reporting on the project. Cell B-11 should also remain unchanged after the initial submittal. Cells B-14 thru B-16 may change over the life of the project if you add additional sub-contractors as the project progresses.
- 3) Once you have completed the OVERALL PROJECT DATA section, begin entering each sub-contractor in the "Individual C/S-C Data Entry Matrix table. Columns F, J, K & L are drop-down selections in the table area. Just pick the appropriate response for these columns. There are "notes" that pop up as you select cells in the columns that help explain what information is needed for each column.
- 4) **IMPORTANT:** Use the tab key to move across the columns. This is necessary in order to avoid generating false information in the cells so that calculations occur appropriately.
- 5) The first two rows of the Matrix are formatted to receive information. They will be identified in bright red when you make the selection of the type of form you are submitting (Cell B-1). To add another row that is properly formatted (like the rows above it), simply press the tab key when you get to the last column in the row you just filled in.
- 6) To change information in a cell, simply type over it or press the Delete key on your keyboard. Using other methods to change data can cause unwanted results. For example, copy and paste can add unwanted data. Using the spacebar to delete information actually leaves behind a space—which is a character—which will cause math errors.
- 7) You must have a State of Oregon Certification Number OR indicate that a contractor is self-identifying as a MWESB. If you have not filled in one of these, then the Name of the Contractor will remain bright red (which is an error symbol).
- 8) All cells in the CALCULATED REPORTING DATA section are automatically generated formulas and cannot be changed.
- 9) Columns to be completed are as follows:
 - Name of MWESB General/ Subcontractor:** List each MWESB used on the project (all tiers). If you as the General, are an MWESB contractor, submit your information in the first row.
 - State of Oregon MWESB Certification Number:** This is the number provided when a contractor or subcontractor applies for and receives this certification. Enter this number.
 - Self-Identified or Other Certified:** If a sub-contractor indicates that they are a women, minority or emerging small business, but doesn't have certification, indicate here by identifying with a "Yes" by picking it from the drop-down box.
 - Initial Sub-Contract Value:** This is the value of the subcontract-with the specific contractor listed, not to be confused with the value of the overall construction contract between the Contractor and the Owner. Once this number is entered, it should not change on subsequent submittals of the form.
 - Sub-Contract value billed within the fiscal year (July 1-June 30):** This is the value for work performed during the year being reported. If your reporting requirements span multiple years due to the size of your project, this information may be replaced by new information for subsequent years.
 - Final Sub-Contract Value:** This is the final value of the sub-contract, including any additions or deductions that occur over the course of the project.

MORE THAN ONE OF THE FOLLOWING CATEGORIES CAN BE SELECTED:

 - Minority-Owned:** Certified by the State of Oregon or self-identifying; select Yes from the drop-down if it applies or leave blank if it does not.
 - Women-Owned:** Certified by the State of Oregon or self-identifying; select Yes from the drop-down if it applies or leave blank if it does not.
 - Emerging Small Business:** Certified by the State of Oregon or self-identifying; select Yes from the drop-down if it applies or leave blank if it does not apply.
- 10) Check your work prior to submitting the document to make sure that all cells in (light green) highlighted rows or columns are completed. If you do not have light green highlights showing up on your document, please return to #1 in this section and follow the directions given. REMEMBER TO SAVE YOUR FILE AGAIN NOW.

Submitting your Form:

Follow the directions as provided by the campus you are contracted with to submit this document. Typically you should be given an E-mail address within your contract transmittal or cover letter for which to submit the file.

SECTION 00 3100
AVAILABLE PROJECT INFORMATION

PART 1 GENERAL

1.01 EXISTING CONDITIONS

- A. Certain information relating to existing conditions and structures is available to bidders but will not be part of the Contract Documents, as follows:
- B. Structural Analysis:
 - 1. A structural review was performed to assess the impact of the new floor system on the existing structure.
 - 2. The report is included in the Appendix of this Project Manual for the Contractor's reference.

PART 2 PRODUCTS (NOT USED)

PART 3 EXECUTION (NOT USED)

END OF SECTION

**SECTION 01 1000
SUMMARY OF WORK**

PART 1 GENERAL

1.01 PROJECT

- A. Project Name: Gerlinger Annex Dance Floor Installation Project.
- B. Owner's Name: University of Oregon.
- C. Architect's Name: PIVOT Architecture.
- D. The Project consists of the installation of new wood dance floors and associated minor demolition.

1.02 CONTRACT DESCRIPTION

- A. Contract Type: A single prime contract based on a Stipulated Price as described in Document 00 5200 - Agreement Form.

1.03 CONSTRUCTION DURATION

- A. Anticipated Date of Notice to Proceed: September 26, 2012.
- B. First day of Winter Break – access to Rooms 350 & 352: December 3, 2012.
- C. Substantial Completion: December 19, 2012.
- D. Final Completion: January 2, 2013.

1.04 DESCRIPTION OF ALTERATIONS WORK

- A. Scope of demolition and removal work is shown on drawings.

1.05 WORK BY OWNER

- A. Owner Furnished, Owner Installed (OFOI). There may be work performed by the Owner concurrent with the work of this contract.
- B. Owner Furnished Contractor Installed (OFCI): New and existing vinyl dance flooring will be provided by Owner for installation by Contractor as described in Section 09 6470 - Wood Dance Flooring. Coordinate scheduling with Owner.

1.06 OWNER OCCUPANCY

- A. Owner intends to continue to occupy adjacent portions of the existing building during the entire construction period.
- B. Owner intends to occupy the Project upon Substantial Completion.
- C. Cooperate with Owner to minimize conflict and to facilitate Owner's operations.
- D. Schedule the Work to accommodate Owner occupancy.
- E. The Owner will identify their primary contact with the Facilities Department, and the primary on-site representative. The Contractor to coordinate with both on a daily basis to confirm the work activity planned for the day, and the next few days.
- F. Provide a detailed Work Sequence showing the next 21 days at each construction meeting. The Work Sequence Schedule to be updated the day of the weekly construction meeting and accurate to describe the work activities planned for the upcoming 21 days to the Contractor's best knowledge.

1.07 CONTRACTOR'S USE OF PREMISES

- A. Except as otherwise stipulated herein, Contractors will have complete use of the Premises within the boundaries of the project as shown on the Drawings for the execution of the Work.
- B. The possession, use, or distribution of illicit drugs and alcohol on the Owner's premises is prohibited. Prescription medications brought to the project site shall be in the original container bearing the name of the drug, the name of the physician and the prescribed dosage.

- C. NO SMOKING POLICY: Smoking is not allowed on the construction site and as additionally limited by city or county ordinance.
- D. Tools and building materials shall never be left out when an unsecured work area is vacated.
- E. Ladders and scaffolding will be taken down when an unsecured work area is vacated.
- F. Open holes and other tripping hazards shall be fenced or barricaded when an unsecured work area is vacated.
- G. Operations resulting in vapors, emissions or flying objects shall be conducted in such a way as to prevent exposure to any unprotected parties or property.
- H. "Secured Work Area" is defined as an area having a perimeter cyclone fence at least 6 feet in height, with gates which close and lock so that no casual entrance is possible by unauthorized personnel.

1.08 REGULAR BUSINESS HOURS

- A. Regular Business Hours shall be the hours between 7 AM and 6 PM, Monday through Friday.

1.09 WORK DURING REGULAR BUSINESS HOURS

- A. Coordinate the use of equipment that causes noise, dust, or noxious odors with the Owner.
- B. The Contractor is prohibited from making excessive noise or vibration to the structure, such as that caused by Jack Hammers, Air Compressors, Electricity Generators, Rivet Guns, Drills, or other similar Devices during Regular Business Hours, except by prior approval of the Owner, and then only for short duration.

1.10 WORK DURING NON-REGULAR BUSINESS HOURS

- A. When the Contractor plans to work on site during other than Regular Business Hours, the Contractor shall give the Owner at least 48 hours notice, in writing, stating when the work will be done, who will be doing the work, and when the work is expected to be completed each day.

1.11 DUST PROTECTION AND SAFETY BARRIERS

- A. The Contractor shall erect temporary Dust and Safety Barriers around all of the Construction Operations to keep dust and debris within the localized work area, and to protect the owner, staff, and the public from construction activities. Additional requirements may be required if airborne dust is judged by the Owner to be a problem.
- B. The Contractor shall take precautions to protect existing smoke detectors from damage or deterioration from dust caused by work of this contract.

1.12 PROTECTING EXISTING UTILITIES

- A. Protect existing utilities from damage, and maintain operation of utilities unless approval is provided by Owner to shut off.
- B. Contractor to inform Owner if they need assistance locating existing utilities that may be within work area.
- C. If Utility Lines are damaged; remove, repair, or replace Lines as directed. Additional compensation and/or extension of time, if any, caused by removing, repairing, or replacing Lines will be determined in accordance with General Conditions.

1.13 PROTECTING EXISTING LANDSCAPING & TREES

- A. Protect existing landscaping from damage caused by work of this contract.

1.14 PROTECT EXISTING STRUCTURES

- A. Contractor shall protect against damage, existing building parts not scheduled for repair or remodel under this contract.
- B. Where necessary to accomplish required protection, provide additional Temporary barricades, cushioning, or other approved Cover over material to be protected.

1.15 ASBESTOS

- A. The wood floors and underlayment have been tested by the Owner, and asbestos-containing materials were not found.
- B. By this notice, the Contractor and the Sub-contractors, and their workers, are asked to be aware of the possible presence of Asbestos Bearing Materials and if found, or even suspected, to immediately stop work in the area, and notify the Architect and the Owners Facility Manager of the location and condition. A separate independent contract will be issued by the Owner to have the suspected material tested and if needed removed or encapsulated.

PART 2 PRODUCTS - NOT USED

PART 3 EXECUTION - NOT USED

END OF SECTION

**SECTION 01 2000
PRICE AND PAYMENT PROCEDURES**

PART 1 GENERAL

1.01 SECTION INCLUDES

- A. Schedule of Values
- B. Procedures for preparation and submittal of applications for progress payments.
- C. Payments for products stored off site.
- D. Documentation of changes in Contract Sum and Contract Time.
- E. Modification procedures.
- F. Correlation of Contractor submittals based on changes.
- G. Procedures for preparation and submittal of application for final payment.

1.02 RELATED REQUIREMENTS

- A. Retainer Contract Supplement
- B. General Conditions
- C. Supplemental Conditions
- D. Section 01 2200 - Unit Prices: Monetary values of unit prices, payment and modification procedures relating to unit prices.

1.03 SCHEDULE OF VALUES

- A. Submit a printed schedule on AIA Form G703 - Application and Certificate for Payment Continuation Sheet.
- B. Electronic media printout including equivalent information will be considered in lieu of standard form specified; submit sample to Architect for approval.
- C. Forms filled out by hand will not be accepted.
- D. Submit Schedule of Values in duplicate within 15 days after date of Owner-Contractor Agreement.
- E. Format: Utilize the Table of Contents of this Project Manual. Identify each line item with number and title of the specification Section. Identify site mobilization and bonds and insurance.
- F. Content: As a basis for computing Progress Payment values, separately list installed value of each of the following:
 - 1. Each major Work Item.
 - 2. Each subcontracted Work Item. For each major Subcontract, list products and operations of that Subcontract as separate Line items.
 - 3. Any Products to be stored, for which separate payments will be requested.
- G. Include within each line item, a direct proportional amount of Contractor's overhead and profit.
- H. Revise schedule to list approved Change Orders, with each Application For Payment.
- I. Round off Values to nearest Dollar.
- J. Sum of Values listed shall equal total Contract Sum.
- K. Substantiating Data: When requested by Architect, submit justifying Substantiating Data and Line Item Amounts in question.
- L. Submit a preliminary draft to the Architect 3 weeks prior to the submittal for the first Application. The purpose preliminary draft is to confirm the level of detail required by the Design Team. The Contractor is to make adjusted requested by the Architect. The level of detail may include values as separate lines (entities) for each Specification Section. The Architect will not review any Application submitted until changes requested by the Architect to the preliminary draft have been incorporated.

1.04 APPLICATIONS FOR PROGRESS PAYMENTS

- A. Payment Period: Monthly.
- B. Form: AIA G702 Application and Certificate for Payment and AIA G703 - Continuation Sheet including continuation sheets when required.
- C. Electronic media printout including equivalent information will be considered in lieu of standard form specified; submit sample to Architect for approval.
- D. Forms filled out by hand will not be accepted.
- E. Execute certification by signature of authorized officer.
- F. Use data from approved Schedule of Values. Provide dollar value in each column for each line item for portion of work performed and for stored Products.
- G. Round off Values to nearest dollar.
- H. List each authorized Change Order as a separate line item, listing Change Order number and dollar amount as for an original item of Work.
- I. Submit four copies of each Application for Payment.
- J. Include the following with the application:
 - 1. Construction progress schedule, revised and current as specified in Section 01 3000.
- K. When Architect requires substantiating information, submit data justifying dollar amounts in question. Provide one copy of data with cover letter for each copy of submittal. Show application number and date, and line item by number and description.
- L. Submit Applications for Payment to Architect at times stipulated above.
- M. When Architect finds Application properly completed and correct, Architect will transmit 2 copies of Certificate for Payment to Owner for approval of payment, with one copy to Contractor, and one retained for files

1.05 PAYMENT FOR PRODUCTS STORED OFF THE PROJECT SITE

- A. When delay or added cost to Owner can be avoided by storing Products off Site, Owner will make payment to Contractor for said Products provided that
- B. Contractor shall:
 - 1. Locate Storage Facilities within 20 miles of the Architect's Office or the Project Site.
 - 2. Make Storage Facilities available for Architect's visual inspection.
 - 3. Segregate and label Stored Products for specified Project.
 - 4. Assume all risk for loss.
 - 5. Assume responsibility for exceeding Product "Shelf-Life".
 - 6. Protect Stored Products and provide applicable Insurance against their damage, discoloration, and theft, listing the Owner and any Mortgagee as Additional Named Insured.
 - 7. Submit itemized Inventory and Schedule of Values for Stored Products together with Certificate of Insurance.
 - 8. Submit payment requests to Owner as part of Contractor's regular Progress Payment Request.
 - 9. Reimburse Owner for damages sustained if Stored Products are not delivered to Jobsite when needed.
 - 10. Submit to Owner, with copy to Architect, a written Waiver of Lien insuring Owner against claims for unpaid Storage Costs.
 - 11. Upon receipt of payment from Owner, prepare and issue to Owner, with a copy for Architect, and any Mortgagee, a Bill of Sale for Stored Products.

1.06 PREVAILING WAGE PAYMENT CERTIFICATION

- A. Submit Prevailing Wage Payment Certification Forms as required by Section 00 73 43 (00820).

1.07 APPLICATION PAYMENT SCHEDULE

- A. Within 15 Days, following Owner's approval of payment of in-order Application for Payment, the Owner will:
 - 1. Until Substantial Completion, pay Ninety-Five Percent (95%) as defined in General Conditions during the previous month, as estimated by Architect.
- B. After execution of Certificate of Substantial Completion, and within 15 days, following Owner's approval of payment of the next in-order Application for Payment, the Owner will pay:
 - 1. Balance due under Contract, excluding a Retainage Amount of at least \$1,000, or double the estimated value of uncompleted and/or unacceptable portions of Work, whichever is the greater amount.
- C. Thirty (30) days after final inspection and acceptance by Owner, and within 15 days following Owner's approval of payment of final in-order Application for Payment, the Owner will pay:
 - 1. Balance due under Contract, provided Work be then fully completed and Contract be then fully performed.

1.08 MODIFICATION PROCEDURES

- A. Submit name of the individual authorized to receive change documents and who will be responsible for informing others in Contractor's employ or subcontractors of changes to the Contract Documents.
- B. For minor changes not involving an adjustment to the Contract Sum or Contract Time, Architect will issue instructions directly to Contractor.
- C. For other required changes, Architect will issue a Construction Change Directive signed by Owner instructing Contractor to proceed with the change, for subsequent inclusion in a Change Order.
 - 1. The document will describe the required changes and will designate method of determining any change in Contract Sum or Contract Time.
 - 2. Promptly execute the change.
- D. For changes for which advance pricing is desired, Architect will issue a Proposal Request which includes a detailed description of a proposed change with supplementary or revised drawings and specifications, a change in Contract Time for executing the change with a stipulation of any overtime work required and the period of time during which the requested price will be considered valid. Contractor shall prepare and submit a fixed price quotation within 7 calendar days.
- E. Contractor may propose a change by submitting a request for change to Architect, describing the proposed change and its full effect on the Work, with a statement describing the reason for the change, and the effect on the Contract Sum and Contract Time with full documentation and a statement describing the effect on Work by separate or other contractors. Document any requested substitutions in accordance with Section 01 6000.
- F. Computation of Change in Contract Amount: As specified in the Agreement and Conditions of the Contract.
 - 1. For change requested by Architect for work falling under a fixed price contract, the amount will be based on Contractor's price quotation.
 - 2. For change requested by Contractor, the amount will be based on the Contractor's request for a Change Order as approved by Architect.
 - 3. For pre-determined unit prices and quantities, the amount will be based on the fixed unit prices.
 - 4. For change ordered by Architect without a quotation from Contractor, the amount will be determined by Architect based on the Contractor's substantiation of costs as specified for Time and Material work.
- G. Substantiation of Costs: Provide full information required for evaluation.
 - 1. provide following data:
 - a. Quantities of products, labor, and equipment.
 - b. Taxes, insurance, and bonds.

- c. Overhead and profit.
 - d. Justification for any change in Contract Time.
 - e. Credit for deletions from Contract, similarly documented.
- 2. Support each claim for additional costs with additional information:
 - a. Origin and date of claim.
 - b. Dates and times work was performed, and by whom.
 - c. Time records and wage rates paid.
 - d. Invoices and receipts for products, equipment, and subcontracts, similarly documented.
- 3. For Time and Material work, submit itemized account and supporting data after completion of change, within time limits indicated in the Conditions of the Contract.
- H. Execution of Change Orders: Architect will issue Change Orders for signatures of parties as provided in the Conditions of the Contract.
- I. After execution of Change Order, promptly revise Schedule of Values and Application for Payment forms to record each authorized Change Order as a separate line item and adjust the Contract Sum.
- J. Promptly revise progress schedules to reflect any change in Contract Time, revise sub-schedules to adjust times for other items of work affected by the change, and resubmit.
- K. Promptly enter changes in Project Record Documents.

1.09 APPLICATION FOR FINAL PAYMENT

- A. Prepare Application for Final Payment as specified for progress payments, identifying total adjusted Contract Sum, previous payments, and sum remaining due.
- B. Application for Final Payment will not be considered until the following have been accomplished:
 - 1. All closeout procedures specified in Section 01 7000.

PART 2 PRODUCTS - NOT USED

PART 3 EXECUTION - NOT USED

END OF SECTION

SECTION 01 3000
ADMINISTRATIVE REQUIREMENTS

PART 1 GENERAL

1.01 SECTION INCLUDES

- A. Preconstruction meeting.
- B. Progress meetings.
- C. Submittals for review, information, and project closeout.
- D. Number of copies of submittals.
- E. Submittal procedures.

1.02 RELATED REQUIREMENTS

- A. Section 01 3216 - Construction Progress Schedule: Form, content, and administration of schedules.
- B. Section 01 7000 - Execution and Closeout Requirements: Additional coordination requirements.
- C. Section 01 7800 - Closeout Submittals: Project record documents.

1.03 CONSTRUCTION ORGANIZATION & START-UP

- A. Responsible Parties:
 - 1. Immediately following Contract execution, Owner will and Contractor shall identify who, within their respective organizations, will be responsible for Project Coordination.
- B. The Owner will Schedule and conduct Preconstruction Meeting.
- C. The Contractor shall establish on-site Lines of Authority and Communications including the following:
 - 1. Schedule attendance at Preconstruction Meeting and schedule and conduct Progress Meetings as specified in Section 01 30 00 (01300).
 - 2. Establish procedures for Intra-project Communications including:
 - a. Submittals.
 - b. Reports & Records.
 - c. Recommendations.
 - d. Coordination Drawings.
 - e. Schedules.
 - f. Resolution of Conflicts.
 - 3. Technical Documents Interpretation:
 - a. Consult with Architect to obtain interpretation.
 - b. Assist in resolution of questions or conflicts which may arise.
 - c. Transmit written interpretations to Subcontractors and to other concerned parties.
 - 4. Permits & Approvals:
 - a. Verify that Subcontractors have obtained required Permits and Inspections for Work and for Temporary Facilities.
 - 5. Control use of Site:
 - a. Supervise Field Engineering and Project Layout.
 - b. Allocate Field Office Space and Work and Storage Areas for use of each Subcontractor.

1.04 COORDINATING SUBCONTRACTORS' WORK

- A. Coordinate the Work of all Subcontractors and make certain that, where the Work of one Trade is dependent upon the Work of another Trade, the Work first installed is properly placed, installed, aligned, and finished as specified or required to properly receive subsequent Materials applied or attached thereto.

- B. Direct Subcontractors to correct defects in Substrates they install when Subcontractors of subsequent Materials have a reasonable and justifiable objection to such surfaces.
- C. Do not force Subcontractors to apply or install Products to improperly placed or improperly finished Substrates that would result in an unsatisfactory or unacceptable finished Product.

1.05 COORDINATING WORK WITH WORK OF OWNER OR OTHER CONTRACTS

- A. Coordinate, and make certain that, where Work of either party is dependent upon the other party, the Work first performed is properly placed, installed, aligned, and finished as required to permit the proper installation of the Work following.
- B. If the Owner's Work in any way interferes with the Contractor's Work, so notify the Owner sufficiently in advance so that the Owner has reasonable time to make necessary adjustments.
- C. If the Contractor's Work in any way interferes with Owner's Work, so notify the Owner as soon as possible. If the Contractor's Work must be modified to accommodate the Owner's Work, except as described elsewhere in this Specification, the Contract Sum and/or the Contract Time will, when necessary be adjusted by a Change Order.

1.06 CLOSE-OUT DUTIES

- A. At completion of Work of each Subcontract, conduct inspection to assure that:
 - 1. Work is acceptable.
 - 2. Specified cleaning has been accomplished, and Temporary Facilities and Debris has been removed from Site.
- B. Substantial Completion:
 - 1. Conduct inspection and prepare list of Work to be completed or corrected.
 - 2. Assist Architect in review of contractor's inspection list and generation of substantial completion punch list.
 - 3. Supervise correction and completion of Work as established in Architect's Observation Reports and substantial completion punch list.
 - 4. Apply for and receive Final Occupancy Permit from Building Department.
 - 5. Complete submittal of Operations and Maintenance Manuals.
 - 6. Complete submittal of Record Drawings.
 - 7. Complete Owner Training.
- C. Final Completion:
 - 1. Assist Architect in checking that all identified deficiencies have been corrected.

PART 2 PRODUCTS - NOT USED

PART 3 EXECUTION

3.01 PRECONSTRUCTION MEETING

- A. Owner will schedule a meeting after Notice of Award.
- B. Attendance Required:
 - 1. Owner.
 - 2. Architect.
 - 3. Contractor.
 - 4. Contractor's Superintendent.
 - 5. Major Subcontractors .
- C. Agenda: (See sample of expanded agenda at end of this section)
- D. Architect will record minutes and distribute copies within five days after meeting to participants, with copies to Owner, participants, and those affected by decisions made.

3.02 PROGRESS MEETINGS

- A. The Contractor will schedule and administer meetings throughout progress of the Work at maximum weekly intervals.
- B. Make arrangements for meetings, prepare agenda with copies for participants, preside at meetings.

- C. Attendance Required: Job superintendent, major Subcontractors and suppliers, Owner, Architect, as appropriate to agenda topics for each meeting.
- D. Agenda:
 - 1. Review minutes of previous meetings.
 - 2. Review of Work progress.
 - 3. Field observations, problems, and decisions.
 - 4. Identification of problems that impede, or will impede, planned progress.
 - 5. Review of submittals schedule and status of submittals.
 - 6. Review of off-site fabrication and delivery schedules.
 - 7. Maintenance of progress schedule.
 - 8. Corrective measures to regain projected schedules.
 - 9. Planned progress during succeeding work period.
 - 10. Coordination of projected progress.
 - 11. Coordination of work of this package with ongoing work of other packages at each site.
 - 12. Maintenance of quality and work standards.
 - 13. Effect of proposed changes on progress schedule and coordination.
 - 14. Other business relating to Work.
- E. The Contractor will record minutes and distribute copies within seven days after meeting to participants, with copies to Architect and Owner, other participants, and those affected by decisions made.

3.03 SUBMITTALS FOR REVIEW

- A. When the following are specified in individual sections, submit them for review:
 - 1. Product data.
 - 2. Shop drawings.
 - 3. Samples for selection.
 - 4. Samples for verification.
 - 5. Other information required in individual specification sections.
- B. Submit to Architect for review for the limited purpose of checking for conformance with information given and the design concept expressed in the contract documents.
- C. Samples will be reviewed only for aesthetic, color, or finish selection.
- D. After review, provide copies and distribute in accordance with SUBMITTAL PROCEDURES article below and for record documents purposes described in Section 01 7800 - CLOSEOUT SUBMITTALS.

3.04 SUBMITTALS FOR PROJECT CLOSEOUT

- A. When the following are specified in individual sections, submit them at project closeout:
 - 1. Project record documents.
 - 2. Operation and maintenance data.
 - 3. Warranties.
 - 4. Bonds.
 - 5. Other information required in individual specification sections.
 - 6. Other types as indicated.
- B. Submit for Owner's benefit during and after project completion.

3.05 NUMBER OF COPIES OF SUBMITTALS

- A. Documents for Review:
 - 1. Small Size Sheets, Not Larger Than 8-1/2 x 11 inches: Submit the number of copies which the Contractor requires, plus two copies which will be retained by the Architect and Owner.
 - a. Provide one additional copy of all civil and structural submittals will be retained by the Engineer.

- b. Provide 2 additional copies of all mechanical and electrical submittals will be retained by the Engineer, and the Owner's Commissioning Agent.
 - 2. Larger Sheets, Not Larger Than 36 x 48 inches: Submit the number of opaque reproductions which Contractor requires, plus two copies which will be retained by Architect and Owner.
 - a. Provide one additional copy of all civil and structural submittals will be retained by the Engineer.
 - b. Provide 2 additional copies of all mechanical and electrical submittals will be retained by the Engineer, and the Owner's Commissioning Agent.
- B. Samples: Submit the number specified in individual specification sections; two of which will be retained by Architect and Owner.
 - 1. After review, produce duplicates.
 - 2. Retained samples will not be returned to Contractor unless specifically so stated.
 - 3. Show full range of color, texture & pattern.

3.06 SUBMITTAL PROCEDURES

- A. Transmit each submittal with a printed transmittal form that clearly describes submittal contents and the quantity of items delivered.
- B. Sequentially number the transmittal form. Revise submittals with original number and a sequential alphabetic suffix.
- C. Identify Project, Contractor, Subcontractor or supplier; pertinent drawing and detail number, and specification section number, as appropriate on each copy.
- D. Apply Contractor's stamp, signed or initialed certifying that review, approval, verification of Products required, field dimensions, adjacent construction Work, and coordination of information is in accordance with the requirements of the Work and Contract Documents.
- E. Deliver submittals to Architect at business address.
- F. Schedule submittals to expedite the Project, and coordinate submission of related items.
- G. For each submittal for review, allow 15 days excluding delivery time to and from the Contractor.
- H. Identify variations from Contract Documents and Product or system limitations which may be detrimental to successful performance of the completed Work.
- I. Notify Architect in writing, at submission time, of any deviations in Submittals from Contract Document requirements.
- J. Provide space for Contractor and Architect review stamps.
- K. When revised for resubmission, identify all changes made since previous submission.
- L. Submit Shop Drawings, Product Data, and Samples only for those Items specifically required. The Architect will not be obligated to review Shop Drawings, Product Data, or Samples other than those required by the Contract Documents.
- M. Product Data:
 - 1. Clearly mark each copy to identify pertinent Products.
 - 2. Show performance characteristics and capacities.
 - 3. Show dimensions, field dimensions, and required clearances.
 - 4. Show wiring and piping diagrams, and controls.
 - 5. Show standard schematic drawings and diagrams:
 - a. Modify to delete information not applicable to Work.
 - b. Supplement standard information to provide information specifically applicable to Work.
 - c. Assure that any photo copied material is clearly legible or provide all original material.
- N. Perform no Work or Fabrication requiring Submittal until Architect approves Submittal.

END OF SECTION

SECTION 01 3216
CONSTRUCTION PROGRESS SCHEDULE

PART 1 GENERAL

1.01 SECTION INCLUDES

- A. Preliminary schedule.
- B. Construction progress schedule, bar chart type.
- C. Three week look ahead schedule

1.02 RELATED SECTIONS

- A. Section 01 1000 - Summary: Work sequence.

1.03 SUBMITTALS

- A. Within 7 days after date of Agreement, submit preliminary schedule defining planned operations for the Project.
- B. If Owner and/or Architect requests revisions after initial review, submit revised schedule within 7 days.
- C. Submit updated schedule with each Application for Payment.
- D. Submit to the Owner and Architect as an electronic PDF document.

1.04 SCHEDULE FORMAT

- A. Listings: In chronological order according to the start date for each activity. Identify each activity with the applicable specification section number.
- B. Sheet Size: Contractor's choice
- C. Scale and Spacing: To allow for notations and revisions.

PART 2 PRODUCTS - NOT USED

PART 3 EXECUTION

3.01 PRELIMINARY SCHEDULE

- A. Prepare preliminary schedule in the form of a horizontal bar chart.

3.02 CONTENT

- A. Show complete sequence of construction by activity, with dates for beginning and completion of each element of construction, and impact to each office of the building.
- B. Identify work of separate stages and other logically grouped activities.
- C. Provide sub-schedules to define critical portions of the entire schedule.
- D. Include conferences and meetings in schedule.
- E. Show accumulated percentage of completion of each item, and total percentage of Work completed, as of the first day of each month.
- F. Provide separate schedule of submittal dates for shop drawings, product data, and samples, and dates reviewed submittals will be required from Architect. Indicate decision dates for selection of finishes.

3.03 BAR CHARTS

- A. Include a separate bar for each major portion of Work or operation.
- B. Identify the first work day of each week.

3.04 THREE WEEK LOOK AHEAD SCHEDULE

- A. Each week during construction, provide companion schedule to master project schedule to look ahead three weeks. Provide increased detail as requested by the Owner or Architect to clearly show the work planned for the upcoming weeks.
- B. Submit at the beginning of each weekly project meeting.

- C. Update as necessary.
- D. Provide a detailed Work Sequence Schedule showing the next 21 days at each weekly construction meeting. The Work Sequence Schedule to be updated the day of the weekly construction meeting and accurately describe the work activities planned for the upcoming 21 days to the Contractor's best knowledge.
 - 1. Identify the deviations in the planned work activities from one week to the other, and clarify the reasons for the deviations.

3.05 REVIEW AND EVALUATION OF SCHEDULE

- A. Participate in joint review and evaluation of schedule with Architect at each submittal.
- B. Evaluate project status to determine work behind schedule and work ahead of schedule.
- C. After review, revise as necessary as result of review, and resubmit within 10 days.

3.06 UPDATING SCHEDULE

- A. Maintain schedules to record actual start and finish dates of completed activities.
- B. Indicate progress of each activity to date of revision, with projected completion date of each activity.
- C. Identify activities modified since previous submittal, major changes in Work, and other identifiable changes.
- D. Indicate changes required to maintain Date of Substantial Completion.

3.07 DISTRIBUTION OF SCHEDULE

- A. Distribute copies of updated schedules to Contractor's project site file, to Subcontractors, suppliers, Architect, Owner, and other concerned parties.
- B. Instruct recipients to promptly report, in writing, problems anticipated by projections shown in schedules.

END OF SECTION

SECTION 01 4000
QUALITY REQUIREMENTS

PART 1 GENERAL

1.01 SECTION INCLUDES

- A. References and standards.
- B. Quality assurance submittals.
- C. Mock-ups.
- D. Control of installation.
- E. Tolerances.
- F. Testing and inspection services.
- G. Manufacturers' field services.

1.02 RELATED REQUIREMENTS

- A. General Conditions
- B. Supplemental Conditions
- C. Section 01 3000 - Administrative Requirements: Submittal procedures.
- D. Section 01 6000 - Product Requirements: Requirements for material and product quality.

1.03 REFERENCE STANDARDS

- A. ASTM C1021 - Standard Practice for Laboratories Engaged in Testing of Building Sealants ; 2008.
- B. ASTM C 1077 - Standard Practice for Laboratories Testing Concrete and Concrete Aggregates for Use in Construction and Criteria for Laboratory Evaluation; 2007.
- C. ASTM C 1093 - Standard Practice for Accreditation of Testing Agencies for Unit Masonry; 2007.
- D. ASTM D3740 - Standard Practice for Minimum Requirements for Agencies Engaged in the Testing and/or Inspection of Soil and Rock as Used in Engineering Design and Construction ; 2010.
- E. ASTM E329 - Standard Specification for Agencies Engaged Construction Inspection and/or Testing ; 2011.
- F. ASTM E543 - Standard Specification for Agencies Performing Nondestructive Testing ; 2009.
- G. OSSC - Oregon Structural Specialty Code, latest edition.

1.04 SUBMITTALS

- A. Design Data: Submit for Architect's knowledge as contract administrator for the limited purpose of assessing conformance with information given and the design concept expressed in the contract documents, or for Owner's information.
- B. Test Reports: After each test/inspection, promptly submit two copies of report to Architect and to Contractor.
 - 1. Include:
 - a. Date issued.
 - b. Project title and number.
 - c. Name of inspector.
 - d. Date and time of sampling or inspection.
 - e. Identification of product and specifications section.
 - f. Location in the Project.
 - g. Type of test/inspection.
 - h. Date of test/inspection.
 - i. Results of test/inspection.

- j. Conformance with Contract Documents.
 - k. When requested by Architect, provide interpretation of results.
 - 2. Test report submittals are for Architect's knowledge as contract administrator for the limited purpose of assessing conformance with information given and the design concept expressed in the contract documents, or for Owner's information.
- C. Certificates: When specified in individual specification sections, submit certification by the manufacturer and Contractor or installation/application subcontractor to Architect, in quantities specified for Product Data.
 - 1. Indicate material or product conforms to or exceeds specified requirements. Submit supporting reference data, affidavits, and certifications as appropriate.
 - 2. Certificates may be recent or previous test results on material or product, but must be acceptable to Architect.
- D. Manufacturer's Instructions: When specified in individual specification sections, submit printed instructions for delivery, storage, assembly, installation, start-up, adjusting, and finishing, for the Owner's information. Indicate special procedures, perimeter conditions requiring special attention, and special environmental criteria required for application or installation.
- E. Manufacturer's Field Reports: Submit reports for Architect's benefit as contract administrator or for Owner.
 - 1. Submit report in duplicate within 30 days of observation to Architect for information.
 - 2. Submit for information for the limited purpose of assessing conformance with information given and the design concept expressed in the contract documents.
- F. Erection Drawings: Submit drawings for Architect's benefit as contract administrator or for Owner.
 - 1. Submit for information for the limited purpose of assessing conformance with information given and the design concept expressed in the contract documents.
 - 2. Data indicating inappropriate or unacceptable Work may be subject to action by Architect or Owner.

1.05 REFERENCES AND STANDARDS

- A. For products and workmanship specified by reference to a document or documents not included in the Project Manual, also referred to as reference standards, comply with requirements of the standard, except when more rigid requirements are specified or are required by applicable codes.
- B. Conform to reference standard of date of issue current on date of Contract Documents, except where a specific date is established by applicable code.
- C. Obtain copies of standards where required by product specification sections.
- D. Maintain copy at project site during submittals, planning, and progress of the specific work, until Substantial Completion.
- E. Should specified reference standards conflict with Contract Documents, request clarification from Architect before proceeding.
- F. Neither the contractual relationships, duties, or responsibilities of the parties in Contract nor those of Architect shall be altered from the Contract Documents by mention or inference otherwise in any reference document.

1.06 TESTING AND INSPECTION AGENCIES

- A. Owner will employ and pay for services of an independent testing agency to perform specified testing and inspection.
- B. Employment of agency in no way relieves Contractor of obligation to perform Work in accordance with requirements of Contract Documents.
- C. Contractor Employed Agency:
 - 1. Testing agency: Comply with requirements of ASTM E 329, ASTM E 548, ASTM E 543, ASTM C 1021, ASTM C 1077, ASTM C 1093, and ASTM D 3740.

2. Inspection agency: Comply with requirements of ASTM D3740, ASTM E329, and ASTM E548.
3. Laboratory: Authorized to operate in the State in which the Project is located.
4. Laboratory Staff: Maintain a full time registered Engineer on staff to review services.
5. Testing Equipment: Calibrated at reasonable intervals either by NIST or using an NIST established Measurement Assurance Program, under a laboratory measurement quality assurance program.

PART 2 PRODUCTS - NOT USED

PART 3 EXECUTION

3.01 CONTROL OF INSTALLATION

- A. Monitor quality control over suppliers, manufacturers, products, services, site conditions, and workmanship, to produce Work of specified quality.
- B. Comply with manufacturers' instructions, including each step in sequence.
- C. Should manufacturers' instructions conflict with Contract Documents, request clarification from Architect before proceeding.
- D. Comply with specified standards as minimum quality for the Work except where more stringent tolerances, codes, or specified requirements indicate higher standards or more precise workmanship.
- E. Have Work performed by persons qualified to produce required and specified quality.
- F. Verify that field measurements are as indicated on shop drawings or as instructed by the manufacturer.
- G. Secure products in place with positive anchorage devices designed and sized to withstand stresses, vibration, physical distortion, and disfigurement.

3.02 MOCK-UPS

- A. Tests will be performed under provisions identified in this section and identified in the respective product specification sections.
- B. Assemble and erect specified items with specified attachment and anchorage devices, flashings, seals, and finishes.
- C. Accepted mock-ups shall be a comparison standard for the remaining Work.
- D. Where mock-up has been accepted by Architect and is specified in product specification sections to be removed, remove mock-up and clear area when directed to do so.

3.03 TOLERANCES

- A. Monitor fabrication and installation tolerance control of products to produce acceptable Work. Do not permit tolerances to accumulate.
- B. Comply with manufacturers' tolerances. Should manufacturers' tolerances conflict with Contract Documents, request clarification from Architect before proceeding.
- C. Adjust products to appropriate dimensions; position before securing products in place.

3.04 TESTING AND INSPECTION

- A. See individual specification sections and the OSSC for testing and inspection required.
- B. Testing Agency Duties:
 1. Test samples of mixes submitted by Contractor.
 2. Provide qualified personnel at site. Cooperate with Architect and Contractor in performance of services.
 3. Perform specified sampling and testing of products in accordance with specified standards.
 4. Ascertain compliance of materials and mixes with requirements of Contract Documents.
 5. Promptly notify Architect and Contractor of observed irregularities or non-conformance of Work or products.

6. Perform additional tests and inspections required by Architect.
 7. Submit reports of all tests/inspections specified.
- C. Limits on Testing/Inspection Agency Authority:
1. Agency may not release, revoke, alter, or enlarge on requirements of Contract Documents.
 2. Agency may not approve or accept any portion of the Work.
 3. Agency may not assume any duties of Contractor.
 4. Agency has no authority to stop the Work.
- D. Contractor Responsibilities:
1. Deliver to agency at designated location, adequate samples of materials proposed to be used that require testing, along with proposed mix designs.
 2. Cooperate with laboratory personnel, and provide access to the Work and to manufacturers' facilities.
 3. Provide incidental labor and facilities:
 - a. To provide access to Work to be tested/inspected.
 - b. To obtain and handle samples at the site or at source of Products to be tested/inspected.
 - c. To facilitate tests/inspections.
 - d. To provide storage and curing of test samples.
 4. Notify Architect and laboratory 24 hours prior to expected time for operations requiring testing/inspection services.
 5. Employ services of an independent qualified testing laboratory and pay for additional samples, tests, and inspections required by Contractor beyond specified requirements.
 6. Arrange with Owner's agency and pay for additional samples, tests, and inspections required by Contractor beyond specified requirements.
- E. Re-testing required because of non-conformance to specified requirements shall be performed by the same agency on instructions by Architect.
- F. Re-testing required because of non-conformance to specified requirements shall be paid for by Contractor.
- G. Re-testing required because of non-conformance to specified requirements shall be performed by the same agency on instructions by Architect. Payment for re testing will be charged to the Contractor by deducting testing charges from the Contract Price.

3.05 MANUFACTURERS' FIELD SERVICES

- A. When specified in individual specification sections, require material or product suppliers or manufacturers to provide qualified staff personnel to observe site conditions, conditions of surfaces and installation, quality of workmanship, start-up of equipment, test, adjust and balance of equipment as applicable, and to initiate instructions when necessary.
- B. Submit qualifications of observer to Architect 30 days in advance of required observations.
 1. Observer subject to approval of Architect.
 2. Observer subject to approval of Owner.
- C. Report observations and site decisions or instructions given to applicators or installers that are supplemental or contrary to manufacturers' written instructions.

3.06 DEFECT ASSESSMENT

- A. Replace Work or portions of the Work not conforming to specified requirements.
- B. If, in the opinion of Architect, it is not practical to remove and replace the Work, Architect will direct an appropriate remedy or adjust payment.

END OF SECTION

SECTION 01 5000
TEMPORARY FACILITIES AND CONTROLS

PART 1 GENERAL

1.01 SECTION INCLUDES

- A. Temporary utilities.
- B. Temporary telecommunications services.
- C. Temporary sanitary facilities.
- D. Temporary Controls: Barriers and enclosures.
- E. Waste removal facilities and services.
- F. Project identification sign.
- G. Field offices.

1.02 TEMPORARY UTILITIES

- A. Owner will provide the following:
 - 1. Electrical power, consisting of connection to existing facilities.
 - 2. Water supply, consisting of connection to existing facilities.
- B. Use trigger-operated nozzles for water hoses, to avoid waste of water.

1.03 TELECOMMUNICATIONS SERVICES

- A. Provide, maintain, and pay for telecommunications services to the project superintendent. A cell phone with voice mail may be used.
- B. Provide, maintain, and pay for a dedicated fax services to the contractor's main office.
- C. Provide, maintain, and pay for internet access service and a dedicated telephone line to the site at time of project mobilization. Provide a computer work station with E-mail service to facilitate communications with Owner and Architect.
 - 1. This service may reside at the Contractor's office for this project if the project superintendent can access the computer in the office and can regularly check for e-mail messages.
- D. Provide a digital camera at the site capable of taking pictures of job conditions and sending .jpg images via e-mail to Owner and Architect.
- E. Provide wall mounted directory at the project work site listing Name and Business Phone Number of at least the following:
 - 1. Each Contractor and Sub-contractor
 - 2. Architect
 - 3. Architect's Consulting Engineers
 - 4. Testing Laboratories
 - 5. Physicians
 - 6. Hospitals
 - 7. Ambulance
 - 8. Local Fire Department

1.04 TEMPORARY SANITARY FACILITIES

- A. Contractor may use Owner's facilities in the building. This is a privilege subject to revocation if not left in a clean condition.

1.05 BARRIERS

- A. Provide barriers to protect workers on the site and the public against injury.
- B. Provide barriers to prevent unauthorized entry to construction areas, to prevent access to areas that could be hazardous to workers or the public , to allow for owner's use of site and to protect existing facilities and adjacent properties from damage from construction operations and demolition.

- C. Provide barricades and covered walkways required by governing authorities for public access to existing building.
- D. Provide protection for plants designated to remain. Replace damaged plants.
- E. Protect non-owned vehicular traffic, stored materials, site, and structures from damage.

1.06 VISITOR PERSONAL PROTECTION EQUIPMENT

- A. Provide six sets of Personal Protection Equipment (PPE) for use by official visitors to the project site during construction. Visitor PPE shall include as a minimum, hard hat and protective eye goggles. Provide high visibility garments when moving vehicles are in use on the construction site. Store in Field Office and reserve for use by visitors to the project site.
- B. Maintain in good condition through the course of the project and replace equipment that does not meet personal safety requirements.

1.07 TEMPORARY FIRE PROTECTION

- A. Provide and maintain necessary facilities and equipment to safeguard Project against Fire Damage.

1.08 EXTERIOR ENCLOSURES

- A. Provide temporary insulated weather tight closure of exterior openings to accommodate acceptable working conditions and protection for Products, to allow for temporary heating and maintenance of required ambient temperatures identified in individual specification sections, and to prevent entry of unauthorized persons. Provide access doors with self-closing hardware and locks.

1.09 VEHICULAR ACCESS AND PARKING

- A. Coordinate access and haul routes with governing authorities and Owner.
- B. Provide and maintain access to fire hydrants, free of obstructions.
- C. Provide means of removing mud from vehicle wheels before entering streets.
- D. The Contractor will need to secure their own parking permits for their use and comply with standard campus parking regulations.
- E. Do not allow vehicle parking on landscaping.
- F. Use designated drop off and delivery areas for short term parking only.
- G. Do not use Owner's Parking Lots for overnight vehicle storage.

1.10 MATERIAL STORAGE SPACE

- A. Maintain within Project Limits in accordance with Architect's and Owner's instructions. Do not block exitways or overload structure.

1.11 WASTE REMOVAL

- A. See Section 01 7419 - Waste Management, for additional requirements.
- B. Provide waste removal facilities and services as required to maintain the site in clean and orderly condition.
- C. Encourage the separation of waste materials and sorting and disposal at a local recycling center.
- D. Provide containers with lids. Remove trash from site periodically.
- E. If materials to be recycled or re-used on the project must be stored on-site, provide suitable non-combustible containers; locate containers holding flammable material outside the structure unless otherwise approved by the authorities having jurisdiction.
- F. Open free-fall chutes are not permitted. Terminate closed chutes into appropriate containers with lids.

1.12 PROJECT IDENTIFICATION

- A. A project sign is not allowed for this project.

- B. No other signs are allowed without Owner permission except those required by law.

1.13 FIELD OFFICES

- A. A permanent Field Office is not required for this project. Coordinate with owner for use of space within the building for the field office. Providing a weathertight field office located within the work limits area is acceptable.
- B. Locate offices a minimum distance of 30 feet from existing structures.

PART 2 PRODUCTS - NOT USED

PART 3 EXECUTION - NOT USED

END OF SECTION

**SECTION 01 6000
PRODUCT REQUIREMENTS**

PART 1 GENERAL

1.01 SECTION INCLUDES

- A. General product requirements.
- B. Environmental requirements.
- C. Transportation, handling, storage and protection.
- D. Product option requirements.
- E. Substitution limitations and procedures.
- F. Procedures for Owner-supplied products.
- G. Maintenance materials, including extra materials, spare parts, tools, and software.

1.02 RELATED REQUIREMENTS

- A. Instructions to Bidders
- B. Supplemental Instructions to Bidders
- C. Section 01 4000 - Quality Requirements: Product quality monitoring.

1.03 REFERENCE STANDARDS

- A. GEI (SCH) - GREENGUARD "Children and Schools" Certified Products; GREENGUARD Environmental Institute ; current listings at www.greenguard.org.
- B. GreenSeal GS-36 - Commercial Adhesives; Green Seal, Inc. ; 2000.
- C. SCAQMD 1168 - South Coast Air Quality Management District Rule No.1168; current edition; www.aqmd.gov.

1.04 SUBMITTALS

- A. Proposed Products List: Submit list of major products proposed for use, with name of manufacturer, trade name, and model number of each product.
 - 1. Submit within 15 days after date of Agreement.
 - 2. For products specified only by reference standards, list applicable reference standards.
- B. Product Data Submittals: Submit manufacturer's standard published data. Mark each copy to identify applicable products, models, options, and other data. Supplement manufacturers' standard data to provide information specific to this Project.
- C. Shop Drawing Submittals: Prepared specifically for this Project; indicate utility and electrical characteristics, utility connection requirements, and location of utility outlets for service for functional equipment and appliances.
- D. Sample Submittals: Illustrate functional and aesthetic characteristics of the product, with integral parts and attachment devices. Coordinate sample submittals for interfacing work.
 - 1. For selection from standard finishes, submit samples of the full range of the manufacturer's standard colors, textures, and patterns.
- E. Indicate utility and electrical characteristics, utility connection requirements, and location of utility outlets for service for functional equipment and appliances.

PART 2 PRODUCTS

2.01 NEW PRODUCTS

- A. Provide new products unless specifically required or permitted by the Contract Documents.
- B. Do not use products having any of the following characteristics:
 - 1. Made using or containing CFC's or HCFC's.
- C. Packaging:

1. Where Contractor has the option to provide one of the listed products or equal, preference shall be given to products with minimal packaging and easily recyclable packaging as defined in ASTM D5834.
2. Maximize use of source reduction and recycling procedures outlined in ASTM D5834.

2.02 ENVIRONMENTAL REQUIREMENTS

- A. Where all other criteria are met, Contractor shall give preference to products that:
 1. Are extracted, harvested, and/or manufactured closer to the location of the project.
 2. Have longer documented life span under normal use.
 3. Result in less construction waste.
 4. Are made of vegetable materials that are rapidly renewable.
- B. Volatile Organic Compound (VOC) Content – Paints and Coatings:
 1. Provision applies to paints and coatings used anywhere on the inside of the building envelope, including primers and sealers.
 2. Provide only products having lower volatile organic compound (VOC) content than required by GreenSeal GS-11 for Paints, and South Coast Air Quality Management District (SCAQMD) Rule #1113, for architectural coatings, sealers, and all other items.
- C. Volatile Organic Compound (VOC) Content – Adhesives and Sealants:
 1. Provision applies to adhesives, sealants, and sealant primers used anywhere on the inside of the building envelope, including primers and sealers.
 2. Provide only products having lower volatile organic compound (VOC) content than required by South Coast Air Quality Management (SCAQMD) Rule #1168.

2.03 PRODUCT OPTIONS

- A. Products Specified by Reference Standards or by Description Only: Use any product meeting those standards or description.
- B. Products Specified by Naming One or More Manufacturers: Use a product of one of the manufacturers named and meeting specifications, no options or substitutions allowed.
- C. Products Specified by Naming One or More Manufacturers with a Provision for Substitutions: Submit a request for substitution for any manufacturer not named.

2.04 MAINTENANCE MATERIALS

- A. Furnish extra materials, spare parts, tools, and software of types and in quantities specified in individual specification sections.
- B. Deliver and place in location as directed; obtain receipt prior to final payment.

PART 3 EXECUTION

3.01 SUBSTITUTION PROCEDURES

- A. Instructions to Bidders specify time restrictions for submitting requests for substitutions during the bidding period. Comply with requirements specified in this section.
- B. Substitutions may be considered when a product becomes unavailable through no fault of the Contractor.
- C. Document each request with complete data substantiating compliance of proposed substitution with Contract Documents.
- D. Substitutions
 1. Notify Owner when Contractor is aware of materials, equipment, or products that meet the aesthetic and programmatic intent of Contract Documents, but which are more environmentally responsible than materials, equipment, or products specified or indicated in the Contract Documents.
- E. A request for substitution constitutes a representation that the submitter:
 1. Has investigated proposed product and determined that it meets or exceeds the quality level of the specified product.
 2. Will provide the same warranty for the substitution as for the specified product.

3. Will coordinate installation and make changes to other Work that may be required for the Work to be complete with no additional cost to Owner.
4. Waives claims for additional costs or time extension that may subsequently become apparent.
5. Will reimburse Owner and Architect for review or redesign services associated with re-approval by authorities.
6. Each request for substitution approval shall include:
 - a. Identity of Product for which substitution is requested; include Specification page and line number.
 - b. Identity of substitution; include complete Product description, drawings, photographs, performance and test data, and any other information necessary for evaluation.
 - c. Identify compliance with any described LEED product requirements.
 - d. Quality comparison of proposed substitution with specified product.
 - e. Changes in other Work required because of substitution.
 - f. Effect on construction progress schedule.
 - g. Cost of proposed substitution compared with specified product.
 - h. Any required license fees or royalties.
 - i. Availability of maintenance service.
 - j. Source of replacement materials.
- F. Substitutions will not be considered when they are indicated or implied on shop drawing or product data submittals, without separate written request, or when acceptance will require revision to the Contract Documents.
- G. Substitution Submittal Procedure:
 1. Submit three copies of request for substitution for consideration. Limit each request to one proposed substitution.
 2. Submit shop drawings, product data, and certified test results attesting to the proposed product equivalence. Burden of proof is on proposer.
 3. The Architect will notify Contractor in writing of decision to accept or reject request.
 4. Architect will be sole judge of acceptability of any proposed substitution.

3.02 SUBSTITUTIONS DURING BIDDING PERIOD

- A. No request for substitution approval will be considered unless written request in triplicate has been submitted on the Substitution Request Form bound hereinafter (01 6023), and has been received by Architect at least three Calendar Days prior to Bid opening.
- B. Architect will issue Addenda prior to Bid opening listing all approved substitutions; requests will not be individually acknowledged.

3.03 SUBSTITUTIONS AFTER CONTRACT AWARD

- A. See "Substitutions During Bidding Period" for procedural requirements.
- B. In addition to the procedures referenced above, approval will be granted only when:
 1. Specified Product cannot be delivered without Project delay, or
 2. Specified Product has been discontinued, or
 3. Specified Product has been replaced by superior Product, or
 4. Specified Product cannot be guaranteed as specified, or
 5. Specified Product will not perform properly, or
 6. Specified Product will not fit within designated space, or
 7. Specified Product does not comply with governing codes, or
 8. Substitution will be clearly in Owner's interest.
- C. Architect will issue Change Order authorizing approved substitutions and revising Contract Sum where appropriate.

3.04 CONTRACT COMPLIANCE

- A. Substitution approval does not relieve Contractor from responsibility for proper execution of the Work and for compliance with other Contract requirements.

3.05 TRANSPORTATION AND HANDLING

- A. Coordinate schedule of product delivery to designated prepared areas in order to minimize site storage time and potential damage to stored materials.
- B. Transport and handle products in accordance with manufacturer's instructions.
- C. Transport materials in covered trucks to prevent contamination of product and littering of surrounding areas.
- D. Promptly inspect shipments to ensure that products comply with requirements, quantities are correct, and products are undamaged.
- E. Provide equipment and personnel to handle products by methods to prevent soiling, disfigurement, or damage.
- F. Arrange for the return of packing materials, such as wood pallets, where economically feasible.

3.06 STORAGE AND PROTECTION

- A. Designate receiving/storage areas for incoming products so that they are delivered according to installation schedule and placed convenient to work area in order to minimize waste due to excessive materials handling and misapplication.
- B. Store and protect products in accordance with manufacturers' instructions.
- C. Store with seals and labels intact and legible.
- D. Store sensitive products in weather tight, climate controlled, enclosures in an environment favorable to product.
- E. For exterior storage of fabricated products, place on sloped supports above ground.
- F. Provide bonded off-site storage and protection when site does not permit on-site storage or protection.
- G. Cover products subject to deterioration with impervious sheet covering. Provide ventilation to prevent condensation and degradation of products.
- H. Store loose granular materials on solid flat surfaces in a well-drained area. Prevent mixing with foreign matter.
- I. Prevent contact with material that may cause corrosion, discoloration, or staining.
- J. Provide equipment and personnel to store products by methods to prevent soiling, disfigurement, or damage.
- K. Arrange storage of products to permit access for inspection. Periodically inspect to verify products are undamaged and are maintained in acceptable condition.

END OF SECTION

**SECTION 01 6023
SUBSTITUTION REQUEST FORM**

SUBSTITUTION REQUEST

1.01 SUBMIT TO:

A. PIVOT ARCHITECTURE, 44 West Broadway Suite 300, Eugene OR 97401-3038

1.02 PROJECT: UNIVERSITY OF OREGON GERLINGER ANNEX DANCE FLOOR REPLACEMENT PROJECT

1.03 SPECIFIED ITEM:

A. NAME: _____

B. SECTION: _____

C. PAGE: _____

D. PARAGRAPH: _____

E. PRODUCT DESCRIPTION: _____

1.04 PROPOSED SUBSTITUTION:

A. MANUFACTURER: _____

B. MODEL: _____

C. PRODUCT DESCRIPTION: _____

D. Attached data includes product description, specifications, drawings, photographs, performance and test data adequate for evaluation of request including identification of applicable data portions.

E. Attached data also includes description of changes to Contract Documents the proposed substitution requires for proper installation.

1.05 UNDERSIGNED CERTIFIES FOLLOWING ITEMS, UNLESS MODIFIED BY ATTACHMENTS, ARE CORRECT:

A. Proposed substitution does not affect dimensions shown on the drawings.

B. Undersigned pays for changes to building design, including engineering design, detailing, and construction costs caused by proposed substitution.

C. Proposed substitution has no adverse effect on other trades, construction schedule, or specified warranty requirements.

D. Maintenance and service parts are available locally or readily obtainable for proposed substitution.

1.06 UNDERSIGNED FURTHER CERTIFIES FUNCTION, APPEARANCE, AND QUALITY OF PROPOSED SUBSTITUTION ARE EQUIVALENT OR SUPERIOR TO SPECIFIED ITEM.

1.07 UNDERSIGNED FURTHER CERTIFIES THAT THE MANUFACTURER OF THE PROPOSED SUBSTITUTION IS AWARE OF THIS SUBSTITUTION REQUEST AND AGREES TO THE STATEMENTS NOTED ABOVE.

1.08 UNDERSIGNED AGREES, IF THIS PAGE IS REPRODUCED, TERMS AND CONDITIONS FOR SUBSTITUTIONS FOUND IN BIDDING DOCUMENTS APPLY TO THIS PROPOSED SUBSTITUTION.

1.09 SUBMITTED BY:

- A. NAME: _____
- B. SIGNATURE: _____
- C. FIRM NAME: _____
- D. ADDRESS: _____
- E. CITY, STATE ZIP: _____
- F. DATE SUBMITTED: _____
- G. PHONE: _____
- H. FAX: _____

1.10 FOR USE BY ARCHITECT OR ENGINEER

- A. APPROVED: _____
- B. APPROVED AS NOTED: _____
- C. NOT APPROVED: _____
- D. RECEIVED TOO LATE: _____
- E. REMARKS: _____
- F. BY: _____
- G. DATE: _____

END OF SECTION

SECTION 01 7000
EXECUTION AND CLOSEOUT REQUIREMENTS

PART 1 GENERAL

1.01 SECTION INCLUDES

- A. Examination, preparation, and general installation procedures.
- B. Pre-installation meetings.
- C. Cutting and patching.
- D. Surveying for laying out the work.
- E. Cleaning and protection.
- F. Starting of systems and equipment.
- G. Demonstration and instruction of Owner personnel.
- H. Closeout procedures, except payment procedures.
- I. Substantial completion
- J. Final Completion
- K. Additional fees for delays in completing work

1.02 RELATED REQUIREMENTS

- A. Section 01 1000 - Summary:
- B. Section 01 3000 - Administrative Requirements: Submittals procedures.
- C. Section 01 4000 - Quality Requirements: Testing and inspection procedures.
- D. Section 01 5000 - Temporary Facilities and Controls: Temporary exterior enclosures.
- E. Section 01 7800 - Closeout Submittals: Project record documents, operation and maintenance data, warranties and bonds.

1.03 SUBMITTALS

- A. See Section 01 3000 - Administrative Requirements, for submittal procedures.
- B. Cutting and Patching: Submit written request in advance of cutting or alteration that affects:
 - 1. Structural integrity of any element of Project.
 - 2. Integrity of weather exposed or moisture resistant element.
 - 3. Efficiency, maintenance, or safety of any operational element.
 - 4. Visual qualities of sight exposed elements.
 - 5. Work of Owner or separate Contractor.
 - 6. Include in request:
 - a. Identification of Project.
 - b. Location and description of affected work.
 - c. Necessity for cutting or alteration.
 - d. Description of proposed work and products to be used.
 - e. Alternatives to cutting and patching.
 - f. Effect on work of Owner or separate Contractor.
 - g. Written permission of affected separate Contractor.
 - h. Date and time work will be executed.

1.04 PROJECT CONDITIONS

- A. Ventilate enclosed areas to assist cure of materials, to dissipate humidity, and to prevent accumulation of dust, fumes, vapors, or gases.
 - 1. Provide negative air pressure by means of fans at exterior doors.
- B. Dust Control: Execute work by methods to minimize raising dust from construction operations. Provide positive means to prevent air-borne dust from dispersing into atmosphere and over adjacent property. Submit a dust control plan to Owner at time of Pre-Construction meeting.

1. Provide HEPA filter units run during work hours in each room to help contain airborne dust.
- C. Noise Control: Provide methods, means, and facilities to minimize noise produced by construction operations.
- D. Pollution Control: Provide methods, means, and facilities to prevent contamination of soil, water, and atmosphere from discharge of noxious, toxic substances, and pollutants produced by construction operations. Comply with federal, state, and local regulations.
- E. Existing HVAC Systems: Provide MERV 8 filters at existing HVAC return grilles mounted low on walls approximately 4 total) to prevent dust from entering the building systems. Coordinate with the Owner to avoid damage to existing systems.

1.05 COORDINATION

- A. Coordinate scheduling, submittals, and work of the various sections of the Project Manual to ensure efficient and orderly sequence of installation of interdependent construction elements , with provisions for accommodating items installed later.
- B. Coordinate completion and clean-up of work of separate sections.
- C. After Owner occupancy of premises, coordinate access to site for correction of defective work and work not in accordance with Contract Documents, to minimize disruption of Owner's activities.

PART 2 PRODUCTS

2.01 PATCHING MATERIALS

- A. New Materials: As specified in product sections; match existing products and work for patching and extending work.
- B. Type and Quality of Existing Products: Determine by inspecting and testing products where necessary, referring to existing work as a standard.
- C. Product Substitution: For any proposed change in materials, submit request for substitution described in Section 01 6000.

PART 3 EXECUTION

3.01 EXAMINATION

- A. Verify that existing site conditions and substrate surfaces are acceptable for subsequent work. Start of work means acceptance of existing conditions.
- B. Verify that existing substrate is capable of structural support or attachment of new work being applied or attached.
- C. Examine and verify specific conditions described in individual specification sections.
- D. Take field measurements before confirming product orders or beginning fabrication, to minimize waste due to over-ordering or misfabrication.
- E. Verify that utility services are available, of the correct characteristics, and in the correct locations.
- F. Prior to Cutting: Examine existing conditions prior to commencing work, including elements subject to damage or movement during cutting and patching. After uncovering existing work, assess conditions affecting performance of work. Beginning of cutting or patching means acceptance of existing conditions.

3.02 PREPARATION

- A. Clean substrate surfaces prior to applying next material or substance.
- B. Seal cracks or openings of substrate prior to applying next material or substance.
- C. Apply manufacturer required or recommended substrate primer, sealer, or conditioner prior to applying any new material or substance in contact or bond.

3.03 PREINSTALLATION MEETINGS

- A. When required in individual specification sections, convene a preinstallation meeting at the site prior to commencing work of the section.
- B. Require attendance of parties directly affecting, or affected by, work of the specific section.
- C. Notify Architect four days in advance of meeting date.
- D. Prepare agenda and preside at meeting:
 - 1. Review conditions of examination, preparation and installation procedures.
 - 2. Review coordination with related work.
- E. Record minutes and distribute copies within four days after meeting to participants, with two copies to Architect, Owner, participants, and those affected by decisions made.

3.04 GENERAL INSTALLATION REQUIREMENTS

- A. Install products as specified in individual sections, in accordance with manufacturer's instructions and recommendations, and so as to avoid waste due to necessity for replacement.
- B. Make vertical elements plumb and horizontal elements level, unless otherwise indicated.
- C. Install equipment and fittings plumb and level, neatly aligned with adjacent vertical and horizontal lines, unless otherwise indicated.
- D. Make consistent texture on surfaces, with seamless transitions, unless otherwise indicated.
- E. Make neat transitions between different surfaces, maintaining texture and appearance.

3.05 SELECTIVE DEMOLITION FOR ALTERATIONS

- A. Drawings showing existing construction and utilities are based on casual field observation and existing record documents only.
 - 1. Verify that construction and utility arrangements are as shown.
 - 2. Report discrepancies to Architect before disturbing existing installation.
 - 3. Beginning of demolition work constitutes acceptance of existing conditions that would be apparent upon examination prior to starting demolition.
- B. Separate areas in which demolition is being conducted from other areas that are still occupied.
 - 1. Provide, erect, and maintain temporary dustproof partitions of construction specified in Section 01 5000 in locations indicated on drawings.
- C. Maintain weatherproof exterior building enclosure except for interruptions required for replacement or modifications; take care to prevent water and humidity damage.
- D. Remove existing work as indicated and as required to accomplish new work.
 - 1. Remove items indicated and/or implied for removal on drawings.
- E. Protect existing work to remain.
 - 1. Perform cutting to accomplish removals neatly and as specified for cutting new work.
 - 2. Repair adjacent construction and finishes damaged during removal work.
 - 3. Patch as specified for patching new work.

3.06 CUTTING AND PATCHING

- A. Whenever possible, execute the work by methods that avoid cutting or patching.
- B. Perform whatever cutting and patching is necessary to:
 - 1. Complete the work.
 - 2. Fit products together to integrate with other work.
 - 3. Provide openings for penetration of mechanical, electrical, and other services.
 - 4. Match work that has been cut to adjacent work.
 - 5. Repair areas adjacent to cuts to required condition.
 - 6. Repair new work damaged by subsequent work.
 - 7. Remove samples of installed work for testing when requested.
 - 8. Remove and replace defective and non-conforming work.

- C. Execute cutting and patching including excavation and fill to complete the work, to uncover work in order to install improperly sequenced work, to remove and replace defective or non-conforming work, to remove samples of installed work for testing when requested, to provide openings in the work for penetration of mechanical and electrical work, to execute patching to complement adjacent work, and to fit products together to integrate with other work.
- D. Execute work by methods that avoid damage to other work and that will provide appropriate surfaces to receive patching and finishing. In existing work, minimize damage and restore to original condition.
- E. Employ skilled and experienced installer to perform cutting for weather exposed and moisture resistant elements, and sight exposed surfaces.
- F. Sawcutting:
 - 1. Employ experienced sawcutting contractor to make all holes, or slab and pavement cutting shown in drawings for architectural, structural, mechanical and electrical work.
 - 2. Do not use water saws in occupied areas, unless otherwise approved.
 - 3. Cut openings square and plumb with sharp edges. Minimize overcutting at corners.
 - 4. Verify location of existing utilities in work area and make proper precautions to protect, disconnect and relocate, or terminate services as directed.
- G. Cut rigid materials using masonry saw or core drill. Minimize overcut at corners. Pneumatic tools not allowed without prior approval.
- H. Restore work with new products in accordance with requirements of Contract Documents.
- I. Fit work air tight to pipes, sleeves, ducts, conduit, and other penetrations through surfaces.
- J. Patching:
 - 1. Finish patched surfaces to match finish that existed prior to patching. On continuous surfaces, refinish to nearest intersection or natural break. For an assembly, refinish entire unit.
 - 2. Match color, texture, and appearance.
 - 3. Repair patched surfaces that are damaged, lifted, discolored, or showing other imperfections due to patching work. If defects are due to condition of substrate, repair substrate prior to repairing finish.
- K. Maintain adequate Temporary Support necessary to assure structural integrity of affected Work.
- L. Protect other portions of Project Work against damage and discoloration.
- M. Protect Work exposed by cutting against damage and discoloration.
- N. Refinish surfaces to match adjacent finish. For continuous surfaces, refinish to nearest intersection or natural break. For an assembly, refinish entire unit.
- O. Make neat transitions. Patch work to match adjacent work in texture and appearance. Where new work abuts or aligns with existing, perform a smooth and even transition.
- P. Patch or replace surfaces that are damaged, lifted, discolored, or showing other imperfections due to patching work. Repair substrate prior to patching finish. Finish patches to produce uniform finish and texture over entire area. When finish cannot be matched, refinish entire surface to nearest intersections.

3.07 PROGRESS CLEANING

- A. Maintain areas free of waste materials, debris, and rubbish. Maintain site in a clean and orderly condition.
- B. Remove debris and rubbish from pipe chases, plenums, attics, crawl spaces, and other closed or remote spaces, prior to enclosing the space.
- C. Broom and vacuum clean interior areas prior to start of surface finishing, and continue cleaning to eliminate dust.

- D. Collect and remove waste materials, debris, and trash/rubbish from site periodically and recycle or dispose off-site; do not burn or bury.

3.08 PROTECTION OF INSTALLED WORK

- A. Protect installed work from damage by construction operations.
- B. Provide special protection where specified in individual specification sections.
- C. Provide temporary and removable protection for installed products. Control activity in immediate work area to prevent damage.
- D. Provide protective coverings at walls, projections, jambs, sills, and soffits of openings.
- E. Protect finished floors, stairs, and other surfaces from traffic, dirt, wear, damage, or movement of heavy objects, by protecting with durable sheet materials.
- F. Prohibit traffic from landscaped areas.
- G. Remove protective coverings when no longer needed; reuse or recycle plastic coverings if possible.

3.09 ADJUSTING

- A. Adjust operating products and equipment to ensure smooth and unhindered operation.

3.10 FINAL CLEANING

- A. Clean all exposed surfaces in rooms where work was performed.
- B. Use cleaning materials that are nonhazardous.
- C. Clean interior glass, surfaces exposed to view; remove temporary labels, stains and foreign substances, polish transparent and glossy surfaces, vacuum carpeted and soft surfaces.
- D. Clean equipment and fixtures to a sanitary condition with cleaning materials appropriate to the surface and material being cleaned.
- E. Clean filters of operating equipment.
- F. Clean site; sweep paved areas.
- G. Remove waste, surplus materials, trash/rubbish, and construction facilities from the site; recycle or dispose of in legal manner; do not burn or bury.

3.11 CLOSEOUT PROCEDURES

- A. Make submittals that are required by governing or other authorities.
 - 1. Provide copies to Architect and Owner.

3.12 SUBSTANTIAL COMPLETION

- A. Notify Architect when work is considered ready for Substantial Completion.
- B. Submit written certification that Contract Documents have been reviewed, work has been inspected, and that work is complete in accordance with Contract Documents and ready for Architect's review.
- C. Contractor shall complete all required maintenance work prior to the date of substantial completion.
- D. When Contractor considers Work substantially complete, as defined in General Conditions, Contractor shall submit to the Architect:
 - 1. Written notice that Work, or designated portion thereof, is substantially complete.
 - 2. List of Items to be completed or corrected.
 - 3. Copy of Final Occupancy Permit.
- E. Architect will, as soon as possible thereafter, make an observation visit to the site to determine completion status.
- F. Should Architect determine that Work is not substantially complete:
 - 1. Architect will promptly notify Contractor in writing, giving reasons therefore.

2. Contractor shall remedy Work deficiencies, and send second notice of substantial completion to Architect.
 3. Architect will review the corrected work.
- G. When Architect concurs that Work is substantially complete, Architect will:
1. Prepare Certificate of Substantial Completion using AIA Form G704, accompanied with Contractor's list of items to be completed or corrected, as verified and amended by Architect. A copy of this Form is bound in the Appendix Section of this manual.
 2. Submit Certificate to Owner and Contractor for their written acceptance of the responsibilities assigned to them in the Certificate.
- H. Owner will occupy portions of the building as specified in Section 01 1000.
- I. Correct items of work listed in executed Certificates of Substantial Completion and comply with requirements for access to Owner-occupied areas.
- J. Notify Architect when work is considered finally complete.
- K. Complete items of work determined by Architect's final inspection.

3.13 FINAL ACCEPTANCE

- A. When Contractor considers Work complete, Contractor shall submit written certification that:
1. Contract Documents have been reviewed.
 2. Contractor has inspected Work for compliance with Contract Documents.
 3. Work has been completed in accordance with Contract Documents.
 4. Equipment and Systems have been tested in presence of Owner's Representative and are operational.
 5. Work is complete and ready for final inspection.
- B. Architect will observe the completed Work to verify completion status as soon as possible after receipt of Contractor's Certification.
- C. Should Architect consider Work incomplete or defective:
1. Architect will promptly notify Contractor in writing, listing incomplete or defective Work.
 2. Contractor shall immediately remedy deficiencies, and send second written certification to Architect that Work is complete.
 3. Architect will review the corrected Work.
- D. When Architect finds Work acceptable under Contract Documents, Architect will request Contractor to make closeout submittals.

3.14 ADDITIONAL FEES FOR DELAYS IN COMPLETING THE WORK

- A. Architect will make 2 Final visits to the project site, one to determine any Work Deficiencies and issue the Substantial Completion Form, and the second to ascertain that Deficiencies have been corrected.
- B. Should Architect be required to make more than the stated 2 final site visits, due to Contractor's failure to correct specified deficiencies:
1. Owner will compensate Architect for additional services.
 2. Owner will deduct Architect's compensation amount from Contractor's final payment as follows:
 - a. Principal's time at \$125.00 per hour.
 - b. Employees' time at \$95.00 per hour.
 - c. Consultant employees and Others at 1.1 times the direct cost incurred.
 - d. Charges will be made for necessary travel time, commercial air fare, auto expense computed at 48.5 cents per mile, room and board, and all other expenses incurred in making inspections.

END OF SECTION

SECTION 01 7419
CONSTRUCTION WASTE MANAGEMENT

PART 1 GENERAL

1.01 WASTE MANAGEMENT REQUIREMENTS

- A. Owner requires that this project generate the least amount of trash and waste possible.
- B. Employ processes that ensure the generation of as little waste as possible due to error, poor planning, breakage, mishandling, contamination, or other factors.
- C. Minimize trash/waste disposal in landfills; reuse, salvage, or recycle as much waste as economically feasible.
- D. Required Recycling, Salvage, and Reuse: The following may not be disposed of in landfills or by incineration:
 - 1. Existing hardwood flooring scheduled for removal in this project.
 - 2. Aluminum and plastic beverage containers.
 - 3. Corrugated cardboard.
 - 4. Wood pallets.
 - 5. Clean dimensional wood.
 - 6. Metals, including packaging banding, metal studs, sheet metal, structural steel, piping, reinforcing bars, door frames, and other items made of steel, iron, galvanized steel, stainless steel, aluminum, copper, zinc, lead, brass, and bronze.
 - 7. Plastic buckets.
 - 8. Fluorescent lamps (light bulbs).
- E. Contractor shall develop and follow a Waste Management Plan designed to implement these requirements.
- F. The following sources may be useful in developing the Waste Management Plan:
 - 1. Lane County Waste Management (541) 682-4119.
- G. Methods of trash/waste disposal that are not acceptable are:
 - 1. Burning on the project site.
 - 2. Burying on the project site.
 - 3. Dumping or burying on other property, public or private.
 - 4. Other illegal dumping or burying.
 - 5. Use of Owner's trash receptacles.
- H. Regulatory Requirements: Contractor is responsible for knowing and complying with regulatory requirements, including but not limited to Federal, state and local requirements, pertaining to legal disposal of all construction and demolition waste materials.

1.02 DEFINITIONS

- A. Clean: Untreated and unpainted; not contaminated with oils, solvents, caulk, or the like.
- B. Construction and Demolition Waste: Solid wastes typically including building materials, packaging, trash, debris, and rubble resulting from construction, remodeling, repair and demolition operations.
- C. Hazardous: Exhibiting the characteristics of hazardous substances, i.e., ignitibility, corrosivity, toxicity or reactivity.
- D. Nonhazardous: Exhibiting none of the characteristics of hazardous substances, i.e., ignitibility, corrosivity, toxicity, or reactivity.
- E. Nontoxic: Neither immediately poisonous to humans nor poisonous after a long period of exposure.
- F. Recyclable: The ability of a product or material to be recovered at the end of its life cycle and remanufactured into a new product for reuse by others.

- G. Recycle: To remove a waste material from the project site to another site for remanufacture into a new product for reuse by others.
- H. Recycling: The process of sorting, cleansing, treating and reconstituting solid waste and other discarded materials for the purpose of using the altered form. Recycling does not include burning, incinerating, or thermally destroying waste.
- I. Return: To give back reusable items or unused products to vendors for credit.
- J. Reuse: To reuse a construction waste material in some manner on the project site.
- K. Salvage: To remove a waste material from the project site to another site for resale or reuse by others.
- L. Sediment: Soil and other debris that has been eroded and transported by storm or well production run-off water.
- M. Source Separation: The act of keeping different types of waste materials separate beginning from the first time they become waste.
- N. Toxic: Poisonous to humans either immediately or after a long period of exposure.
- O. Trash: Any product or material unable to be reused, returned, recycled, or salvaged.
- P. Waste: Extra material or material that has reached the end of its useful life in its intended use. Waste includes salvageable, returnable, recyclable, and reusable material.

1.03 SUBMITTALS

- A. See Section 01 3000 - Administrative Requirements, for submittal procedures.
- B. Submit Waste Management Plan within 10 calendar days after receipt of Notice of Award of Bid, or prior to any trash or waste removal, whichever occurs sooner; submit projection of all trash and waste that will require disposal and alternatives to landfilling.
- C. Waste Management Plan: Include the following information:
 - 1. Analysis of the trash and waste projected to be generated during the entire project construction cycle, including types and quantities.
 - 2. Landfill Alternatives: List all waste materials that will be diverted from landfills by reuse, salvage, or recycling.

PART 2 PRODUCTS

2.01 NOT USED

PART 3 EXECUTION

3.01 WASTE MANAGEMENT PROCEDURES

- A. See Section 01 1000 for list of items to be salvaged from the existing building for relocation in project or for Owner.
- B. See Section 01 3000 for additional requirements for project meetings, reports, submittal procedures, and project documentation.
- C. See Section 01 5000 for additional requirements related to trash/waste collection and removal facilities and services.
- D. See Section 01 6000 for waste prevention requirements related to delivery, storage, and handling.
- E. See Section 01 7000 for trash/waste prevention procedures related to demolition, cutting and patching, installation, protection, and cleaning.

3.02 WASTE MANAGEMENT PLAN IMPLEMENTATION

- A. Manager: Designate an on-site person or persons responsible for instructing workers and overseeing and documenting results of the Waste Management Plan.
- B. Communication: Distribute copies of the Waste Management Plan to job site foreman, each subcontractor, Owner, and Architect.

- C. Instruction: Provide on-site instruction of appropriate separation, handling, and recycling, salvage, reuse, and return methods to be used by all parties at the appropriate stages of the project.
- D. Meetings: Discuss trash/waste management goals and issues at project meetings.
- E. Facilities: Provide specific facilities for separation and storage of materials for recycling, salvage, reuse, return, and trash disposal, for use by all contractors and installers.
 - 1. As a minimum, provide:
 - a. Separate area for storage of materials to be reused on-site, such as wood cut-offs for blocking.
 - b. Separate dumpsters for each category of recyclable.
 - 2. Provide containers as required.
 - 3. Provide adequate space for pick-up and delivery and convenience to subcontractors.
 - 4. Keep recycling and trash/waste bin areas neat and clean and clearly marked in order to avoid contamination of materials.
- F. Hazardous Wastes: Separate, store, and dispose of hazardous wastes according to applicable regulations.
- G. Recycling: Separate, store, protect, and handle at the site identified recyclable waste products in order to prevent contamination of materials and to maximize recyclability of identified materials. Arrange for timely pickups from the site or deliveries to recycling facility in order to prevent contamination of recyclable materials.
- H. Reuse of Materials On-Site: Set aside, sort, and protect separated products in preparation for reuse.
- I. Salvage: Set aside, sort, and protect products to be salvaged for reuse off-site.

END OF SECTION

**SECTION 01 7800
CLOSEOUT SUBMITTALS**

PART 1 GENERAL

1.01 SECTION INCLUDES

- A. Project record documents.
- B. Operation and maintenance data.
- C. Warranties and bonds.

1.02 RELATED REQUIREMENTS

- A. General Conditions
- B. Supplemental Conditions
- C. Section 01 3000 - Administrative Requirements: Submittals procedures, shop drawings, product data, and samples.
- D. Section 01 7000 - Execution and Closeout Requirements: Contract closeout procedures.
- E. Individual Product Sections: Specific requirements for operation and maintenance data.
- F. Individual Product Sections: Warranties required for specific products or Work.

1.03 SUBMITTALS

- A. Substantial Completion will not commence before the Operations and Maintenance Manuals, Warranties, and the Record Drawings are submitted in accordance with Section 01 70 00.
- B. Project Record Documents: Submit documents to Architect prior to substantial completion.
- C. Operation and Maintenance Data:
 - 1. Submit two copies of preliminary draft or proposed formats and outlines of contents before start of Work. Architect will review draft and return one copy with comments.
 - 2. For equipment, or component parts of equipment put into service during construction and operated by Owner, submit completed documents within ten days after acceptance.
 - 3. Submit 1 copy of completed documents 45 days prior to substantial completion. This copy will be reviewed and returned with Architect comments. Revise content of all document sets as required prior to final submission.
 - 4. Submit 3 copies of revised final documents in final form prior to substantial completion.
- D. Warranties and Bonds:
 - 1. For equipment or component parts of equipment put into service during construction with Owner's permission, submit documents within 10 days after acceptance.
 - 2. Make other submittals within 10 days after Date of Substantial Completion, prior to final Application for Payment.
 - 3. For items of Work for which acceptance is delayed beyond Date of Substantial Completion, submit within 10 days after acceptance, listing the date of acceptance as the beginning of the warranty period.

PART 2 PRODUCTS - NOT USED

PART 3 EXECUTION

3.01 PROJECT RECORD DOCUMENTS

- A. Maintain on site one set of the following record documents; record actual revisions to the Work:
 - 1. Drawings.
 - 2. Specifications.
 - 3. Addenda.
 - 4. Change Orders and other modifications to the Contract.
 - 5. Reviewed shop drawings, product data, and samples.
 - 6. Manufacturer's instruction for assembly, installation, and adjusting.
- B. Maintenance of documents and samples.

1. Store in Contractor's Field Office apart from Documents used for Construction.
 2. Provide Files, Shelving and Cabinets necessary to safely and securely store Documents and Samples.
 3. Maintain Documents in a clean, dry, legible, and good order.
 4. Do not use Record Documents for Construction Purposes.
 5. Make Documents available at all time for Architect's inspection
- C. Ensure entries are complete and accurate, enabling future reference by Owner.
- D. Store record documents separate from documents used for construction.
- E. Record information concurrent with construction progress. Use waterproof, felt-tip pens
- F. Color code recorded information, unless otherwise directed or approved.
1. Red: Document Changes.
 2. Green: Work deleted.
 3. Blue: Dimensional and other notations.
- G. Specifications: Legibly mark and record at each product section description of actual products installed, including the following:
1. Manufacturer's name and product model and number.
 2. Product substitutions or alternates utilized.
 3. Changes made by Addenda and modifications.
- H. Record Drawings and Shop Drawings: Legibly mark each item to record actual construction including:
1. Measured depths of foundations in relation to finish first floor datum.
 2. Measured horizontal and vertical locations of underground utilities and appurtenances, referenced to permanent surface improvements.
 3. Measured locations of internal utilities and appurtenances concealed in construction, referenced to visible and accessible features of the Work.
 4. Field changes of dimension and detail.
 5. Details not on original Contract drawings.

3.02 OPERATION AND MAINTENANCE DATA - GENERAL

- A. For Each Product or System: List names, addresses and telephone numbers of Subcontractors and suppliers, including local source of supplies and replacement parts.
- B. Product Data: Mark each sheet to clearly identify specific products and component parts, and data applicable to installation. Delete inapplicable information.
- C. Drawings: Supplement product data to illustrate relations of component parts of equipment and systems, to show control and flow diagrams. Do not use Project Record Documents as maintenance drawings.
- D. Typed Text: As required to supplement product data. Provide logical sequence of instructions for each procedure, incorporating manufacturer's instructions.
- E. Unless noted otherwise, provide three complete sets.

3.03 OPERATION AND MAINTENANCE DATA FOR MATERIALS AND FINISHES

- A. For Each Product, Applied Material, and Finish:
 1. Product data, with catalog number, size, composition, and color and texture designations.
 2. Information for re-ordering custom manufactured products.
- B. Instructions for Care and Maintenance: Manufacturer's recommendations for cleaning agents and methods, precautions against detrimental cleaning agents and methods, and recommended schedule for cleaning and maintenance.
- C. Moisture protection and weather-exposed products: Include product data listing applicable reference standards, chemical composition, and details of installation. Provide recommendations for inspections, maintenance, and repair.
- D. Additional information as specified in individual product specification sections.

3.04 OPERATION AND MAINTENANCE MANUALS

- A. Prepare instructions and data by personnel experienced in maintenance and operation of described products.
- B. Prepare data in the form of an instructional manual.
- C. Binders: Commercial quality, 8-1/2 by 11 inch three D side ring binders with durable plastic covers; 2 inch maximum ring size. When multiple binders are used, correlate data into related consistent groupings.
- D. Cover: Identify each binder with typed or printed title OPERATION AND MAINTENANCE INSTRUCTIONS; identify title of Project; identify subject matter of contents.
- E. Provide tabbed dividers for each separate product and system, with typed description of product and major component parts of equipment.
- F. Text: Manufacturer's printed data, or typewritten data on 24 pound paper.
- G. Drawings: Provide with reinforced punched binder tab. Bind in with text; fold larger drawings to size of text pages.
- H. Arrange content by systems under section numbers and sequence of Table of Contents of this Project Manual.
- I. Contents: Prepare a Table of Contents for each volume, with each product or system description identified, in three parts as follows:
 - 1. Part 1: Directory, listing names, addresses, and telephone numbers of Architect, Contractor, Subcontractors, and major equipment suppliers.
 - 2. Part 2: Operation and maintenance instructions arranged by system and subdivided by specification section. For each category, identify names, addresses, and telephone numbers of Subcontractors and suppliers. Identify the following:
 - a. Significant design criteria.
 - b. List of equipment.
 - c. Parts list for each component.
 - d. Operating instructions.
 - e. Maintenance instructions for equipment and systems.
 - f. Maintenance instructions for special finishes, including recommended cleaning methods and materials, and special precautions identifying detrimental agents.
 - 3. Part 3: Project documents and certificates, including the following:
 - a. Shop drawings and product data.
 - b. Air and water balance reports.
 - c. Certificates.
 - d. Photocopies of warranties and bonds.
- J. Provide a listing in Table of Contents for design data, with tabbed dividers and space for insertion of data.
- K. Table of Contents: Provide title of Project; names, addresses, and telephone numbers of Architect, Consultants, and Contractor with name of responsible parties; schedule of products and systems, indexed to content of the volume.

3.05 WARRANTIES AND BONDS

- A. Obtain warranties and bonds, executed in duplicate by responsible Subcontractors, suppliers, and manufacturers, within 10 days after completion of the applicable item of work. Except for items put into use with Owner's permission, leave date of beginning of time of warranty until the Date of Substantial completion is determined.
- B. Verify that documents are in proper form and contain full information.
- C. Co-execute submittals when required.
- D. Retain warranties and bonds until time specified for submittal.

- E. Manual: Bind in commercial quality 8-1/2 by 11 inch three D side ring binders with durable plastic covers.
- F. Cover: Identify each binder with typed or printed title WARRANTIES AND BONDS, with title of Project; name, address and telephone number of Contractor and equipment supplier; and name of responsible company principal.
- G. Table of Contents: Neatly typed, in the sequence of the Table of Contents of the Project Manual, with each item identified with the number and title of the specification section in which specified, and the name of product or work item.
- H. Separate each warranty or bond with index tab sheets keyed to the Table of Contents listing. Provide full information, using separate typed sheets as necessary. List Subcontractor, supplier, and manufacturer, with name, address, and telephone number of responsible principal.

3.06 EVIDENCE OF PAYMENTS & RELEASE OF LIENS

- A. Contractor shall submit the following:
 - 1. Contractor's Affidavit of Payment of Debts and Claims, AIA Document G-706. A copy of this Form is bound in the Appendix Section of this manual.
 - 2. Contractor's Affidavit of Release of Liens, AIA Document G-706A, bound in the Appendix Section of this manual, including the following:
 - a. Consent of Contractor's Surety to Final Payment, AIA Document G-707A, bound in the Appendix Section of this manual.
 - b. Contractor's Release or Waiver of Liens.
 - c. Separate releases or waivers of lien for Subcontractors, Suppliers, and others with lien rights against Owner's Property, together with list of those parties.
 - 3. Duly sign and execute all Submittals, before delivery to Architect.

3.07 CONTRACTOR'S CLOSEOUT SUBMITTALS TO ARCHITECT

- A. Certificate of Insurance for Products & Completed Operations: See Sections 00 72 00 and 00 73 00.
- B. Wage Certification: Section 00 73 43 and 01 20 00.

3.08 SPARE PART & MAINTENANCE MATERIAL SUBMITTALS TO OWNER

- A. All spare parts and extra material are to be delivered to the owner prior to the date of substantial completion. Provide written confirmation of delivery, noting quantity and description as well as storage location. Obtain written acceptance from Owner for receipt of stored items.
- B. Specific Requirements: See Specifications Sections.
- C. Products: Identical to those included in Project Work.
- D. Storage Location: Where directed by Owner.
- E. Required Submittals: See Specification Sections.

3.09 FINAL ADJUSTMENT OF ACCOUNTS

- A. Submit final statement of accounting to Architect, including the following:
 - 1. Original Contract Sum.
 - 2. Additions and deductions resulting from:
 - a. Previous Change Orders.
 - b. Adjustments to Cash Allowances
 - c. Other adjustments.
 - d. Deductions for uncompleted Work.
 - e. Deductions for Reinspection Payments.
 - 3. Total Contract Sum, as adjusted.
 - 4. Previous Payments.
 - 5. Sum remaining due.

- B. Architect will prepare and issue final Change Order, reflecting approved adjustments to Contract Sum not previously made by Change Orders.

3.10 FINAL APPLICATION FOR PAYMENT

- A. Follow procedures specified in Section 01 20 00.

END OF SECTION

**SECTION 06 2000
FINISH CARPENTRY**

PART 1 GENERAL

1.01 SECTION INCLUDES

- A. Running wall base.

1.02 RELATED REQUIREMENTS

- A. Section 09 6470 - Wood Dance Flooring: Sprung wood floor system and transition ramps.
- B. Section 09 9000 - Painting and Coating: Finishing of finish carpentry items.

1.03 REFERENCE STANDARDS

- A. AWI/AWMAC/WI (AWS) - Architectural Woodwork Standards ; 2009.

1.04 SUBMITTALS

- A. See Section 01 3000 - Administrative Requirements for submittal procedures.
- B. Samples: Submit two samples of each type wood trim 12 inch long, illustrating wood grain.

1.05 QUALITY ASSURANCE

- A. Fabricator Qualifications: Company specializing in fabricating the products specified in this section with minimum five years of documented experience.

1.06 DELIVERY, STORAGE, AND HANDLING

- A. Do not deliver Products to Jobsite until notified by General Contractor that Project is conditioned and prepared to handle and store Products without damage or discoloration.
- B. Protect work from moisture damage.
- C. Protect material from discoloration due to uneven exposure to light.

PART 2 PRODUCTS

2.01 FINISH CARPENTRY ITEMS

- A. Quality Grade: Unless otherwise indicated provide products of quality specified by AWI//AWMAC/WI Architectural Woodwork Standards for Custom Grade.

2.02 LUMBER MATERIALS

- A. Hardwood Lumber: Maple or Birch species to match wood flooring specified in Section 09 6470, plain sawn, maximum moisture content of 6 percent ; with vertical grain , of quality suitable for transparent finish.
 - 1. Board thickness: 1-1/4 inch finished dimension.
 - 2. Profile: Beveled top edge as indicated.

2.03 FASTENINGS

- A. Fasteners: Finish nails of size and type to suit application.

2.04 ACCESSORIES

- A. Wood Filler: Solvent base, tinted to match surface finish color.

PART 3 EXECUTION

3.01 EXAMINATION

- A. Verify adequacy of backing and support framing.

3.02 INSTALLATION

- A. Install work in accordance with AWI/AWMAC/WI Architectural Woodwork Standards requirements for grade indicated.

- B. Set and secure materials and components in place, plumb and level.
- C. Carefully scribe work abutting other components, with maximum gaps of 1/32 inch. Do not use additional overlay trim to conceal larger gaps.
- D. Match existing building trim details, design, and treatment.
- E. Miter corners.
- F. Ease sharp external corners and edges.
- G. Kerf Backs of Flat Grain Members more than 5 inches wide or more than 1 inch Nominal thickness.
- H. Install trim with nails at 16 inch on center into existing nailing strips in concrete walls.
- I. Bevel cut and glue end joints.
- J. Set exposed nails 1/16 inch below surface. Apply wood filler in exposed fastener indentations.

3.04 TOLERANCES

- A. Maximum Variation from True Position: 1/16 inch.
- B. Maximum Offset from True Alignment with Abutting Materials: 1/32 inch.

END OF SECTION

**SECTION 09 6470
WOOD DANCE FLOORING**

PART 1 GENERAL

1.1 SECTION INCLUDES

- A. Sprung wood dance flooring system.
- B. Vinyl performance surface, OFCI.

1.2 RELATED SECTIONS

- A. Section 01 7000 - Execution Requirements: Wood sub-floor preparation and tolerances.

1.3 SUBMITTALS

- A. Submit under provisions of Section 01 3000.
- B. Product Data: Manufacturer's data sheets on each product to be used, including:
 - 1. Preparation instructions and recommendations.
 - 2. Storage and handling requirements and recommendations.
 - 3. Installation methods.
- C. Shop Drawings:
 - 1. Layout of flooring and details of installation.
- D. Selection Samples: For each finish product specified, two complete sets of color samples representing manufacturer's full range of available colors and patterns.
- E. Verification Samples: For each finish product specified, two samples, minimum size 6 inches (150 mm) square, representing actual product, color, and patterns.
- F. Operations and Maintenance Data:
 - 1. Operations Guide: Provide standards for maximum moving loads per panel, for Owner's use managing equipment and lifts on the floor system.
 - 2. Maintenance Instructions: Provide guidelines for cleaning and touch up of floor finish.

1.4 QUALITY ASSURANCE

- A. Installer Qualifications: Installing company and crew foreman shall have experience installing sprung wood floor systems of similar size and complexity with at least two similar projects in the last five years.
- B. Mock-Up:
 - 1. Install 8 panels and allow Owner to review surface preparation techniques and installation workmanship.
 - 2. Do not proceed with remaining work until mock-up is reviewed and accepted by Owner.
 - 3. Refinish mock-up area as required to produce acceptable work.
 - 4. Mock-up may remain as part of Work.

1.5 DELIVERY, STORAGE, AND HANDLING

- A. Store products in manufacturer's unopened packaging until ready for installation.
- B. Store and dispose of solvent-based materials, and materials used with solvent-based materials, in accordance with requirements of local authorities having jurisdiction.

1.6 PROJECT CONDITIONS

- A. Permanent heat, light and ventilation shall be installed and operating during and after installation, maintaining a temperature range of 60 to 75 degrees F (15.5 degrees to 24 degrees C) and a relative humidity range of 35 percent to 50 percent.

1.7 WARRANTY

- A. Manufacturer warrants its wood floor construction materials to be free from manufacturing defects for a minimum of two years.

PART 2 PRODUCTS

2.1 MANUFACTURERS

- A. Acceptable Manufacturers:
 - 1. American Harlequin Corporation; 1531 Glen Ave., Moorestown, NJ 08057; (800) 642-6440; www.harlequinfloors.com.
 - 2. Substitutions: Manufacturers offering equivalent systems will be reviewed in accordance with provisions of Section 01 6000.

2.2 SPRUNG FLOOR SYSTEM

- A. System: Permanent or semi-permanent panel floor system comprised of multiple, fully pre-manufactured panels that are joined by means of a modified tongue and groove interconnection. Similar to Harlequin "Liberty Permanent Sprung Floor System."
- B. Performance:
 - 1. Maximum Static Load: 1200 lb (650 kg).
 - 2. Maximum Dynamic Load: 555 lb (300 kg).
 - 3. Weight per panel (permanent installation): 80 lb (36.5 kg).
 - 4. Overall Thickness: 1-1/2 inches (37 mm) plus flooring.
 - 5. Designed to support the ASCE 7 uniform static design load of 100psf for dance floors.
- C. Panel Material: 3/4 inch (19 mm) thick, Maple face veneer, engineered hardwood core, with water resistant phenolic resins yielding void free density of 41.3 lb/cf (656 kg/cu. M), cross band reinforced.
- D. Panel Size: 48 x 96 inches or 48 x 48 inches.
- E. Suspension: Synthetic, closed cell, cellular urethane, 3/4 inch (19 mm) thick, (length, width, and pattern of placement as engineered by manufacturer), Dual-Durometer, combined low and high modulus. Flammability burn rate (inches per minute) = 0. Suspension pads factory installed onto panels.
- F. Panel Finish: Clear, abrasion resistant, nonflammable, 1 coat polyurethane on panel bottom and all edges; 2 coats on panel top.
- G. Panel Joints: Dowel tongue, hardwood, uniform concentricity, diameter 3/8 inch (9.5 mm), length variable.
- H. Panel Bottom: none.
- I. Accessories:
 - 1. As required by manufacturer for a complete installation.
 - 2. Solid maple transition ramp, as detailed, stained dark brown, and coated to match flooring.

2.3 VINYL PERFORMANCE SURFACE (OFCI)

- A. Room 350: New vinyl flooring, "Adagio" by Rosco; 1.5mm thickness, 63 inches wide x 79 foot rolls; 2.42 pounds per linear foot.
- B. Room 352: Existing vinyl flooring to be removed and reinstalled, same material as Room 350.
- C. Both Rooms: Seam tape: 2 inch x 36 yard, by Rosco.

PART 3 EXECUTION

3.1 PREPARATION

- A. Prepare surfaces using the methods recommended by the manufacturer for achieving the best result for the substrate under the project conditions.
 - 1. Wood sub floors shall be structurally sound, and level. Loose boards and nails shall be secured and gaps filled.
- B. Carefully remove existing vinyl flooring from Room 352, loosely roll and store in the room for later reinstallation. Remove all existing seam tape from vinyl prior to storage.

3.2 INSTALLATION

- A. Install systems in accordance with manufacturer's instructions.
- B. Sprung Wood Panel Installation:
 - 1. Flooring shall be stored on the premises for 24-48 hours before installation commences, or as required for acclimation. The flooring installer will make final determination of acclimation period.
 - 2. Install flooring parallel to long dimension of room, square and true, with panels tight together. Offset joints of subsequent panels.
 - 3. Secure perimeter panels to subfloor with countersunk fasteners, leaving a 3/4 inch gap at all walls.
- C. Vinyl Installation:
 - 1. Install new and existing vinyl with seam tape in each room. Manufacturer's instructions available at <http://www.rosco.com/technotes/floors/FloorInstallManual.pdf>.

3.3 PROTECTION

- A. Protect installed products until completion of project.
- B. Touch-up, repair or replace damaged products before Substantial Completion.

END OF SECTION

**SECTION 09 9000
PAINTING AND COATING**

PART 1 GENERAL

1.01 SECTION INCLUDES

- A. Shop or field application of varnishes.

1.02 RELATED REQUIREMENTS

- A. Section 09 6470 - Wood Dance Flooring: Prefinished wood dance flooring.

1.03 REFERENCE STANDARDS

- A. 40 CFR 59, Subpart D - National Volatile Organic Compound Emission Standards for Architectural Coatings; U.S. Environmental Protection Agency ; current edition.
- B. GreenSeal GS-11 - Architectural Paints ; 1993.
- C. MPI (APL) - Master Painters Institute Approved Products List; Master Painters and Decorators Association ; current edition, www.paintinfo.com.
- D. MPI (APSM) - Master Painters Institute Architectural Painting Specification Manual; Master Painters and Decorators Association ; 2004.

1.04 SUBMITTALS

- A. See Section 01 3000 - Administrative Requirements, for submittal procedures.
- B. Product Data: Provide complete list of all products to be used, with the following information for each:
 - 1. Manufacturer's name, product name and/or catalog number, and general product category (e.g. "alkyd enamel").
 - 2. MPI product number (e.g. MPI #47).
 - 3. Cross-reference to specified paint system(s) product is to be used in; include description of each system (copy of relevant MPI Manual page is acceptable).
 - 4. Manufacturer's installation instructions and surface preparation procedures.
 - 5. If proposal of substitutions is allowed under submittal procedures, submit an explanation of all substitutions proposed.
- C. Certification: By manufacturer that all paints and coatings do not contain any of the prohibited chemicals specified; GreenSeal GS-11 certification is not required but if provided shall constitute acceptable certification.
- D. Maintenance Data: Submit data on cleaning, touch-up, and repair of painted and coated surfaces.

1.05 QUALITY ASSURANCE

- A. Manufacturer Qualifications: Company specializing in manufacturing the Products specified in this section with minimum three years experience.
- B. Applicator Qualifications: Company specializing in performing the work of this section with minimum five years experience.
- C. Material Safety Data Sheets: At project site maintain file of MSDS sheets for each product used; become familiar with and follow manufacturer's stated application and safety requirements.

1.06 DELIVERY, STORAGE, AND HANDLING

- A. Deliver products to site in sealed and labeled containers; inspect to verify acceptability.
- B. Container Label: Include manufacturer's name, type of paint, brand name, lot number, brand code, coverage, surface preparation, drying time, cleanup requirements, color designation, and instructions for mixing and reducing.
- C. Store and dispose of solvent-based materials, and materials used with solvent-based materials, in accordance with requirements of local authorities having jurisdiction over project.

1.07 FIELD CONDITIONS

- A. Do not apply materials when surface and ambient temperatures are outside the temperature ranges required by the paint product manufacturer.
- B. Follow manufacturer's recommended procedures for producing best results, including testing of substrates, moisture in substrates, and humidity and temperature limitations.

1.08 EXTRA MATERIALS

- A. See Section 01 6000 - Product Requirements, for additional provisions.
- B. Supply 1 quart of each product; store where directed.
- C. Label each container with color, type, texture, and project title and date in addition to the manufacturer's label.

PART 2 PRODUCTS

2.01 MANUFACTURERS

- A. Provide all paint and coating products used in any individual system from the same manufacturer; no exceptions.
- B. Paints, Transparent Finishes and Stains: Acceptable manufacturers are limited to the following:
 - 1. Glidden Professional / Devco Coatings (formerly ICI Paints): www.gliddenprofessional.com or www.devoecoatings.com
 - 2. Benjamin Moore & Co: www.benjaminmoore.com
 - 3. Parker Paint: www.parkerpaint.com
 - 4. PPG Architectural Finishes, Inc: www.ppgaf.com
 - 5. Rodda: www.roddavision.com
 - 6. Sherwin-Williams Co: www.sherwin-williams.com
 - 7. Miller Paint; www.millerpaint.com
- C. Substitutions: See Section 01 6000 - Product Requirements.

2.02 MATERIALS - GENERAL

- A. Volatile Organic Compound (VOC) Content:
 - 1. Provide coatings that comply with the most recent and stringent requirements specified in the following:
 - a. Architectural coatings VOC limits of State in which the project is located.
 - b. South Coast Air Quality Management District (SCAQMD) Rule #1113, Architectural Coatings.
 - 2. Determination of VOC Content: Testing and calculation in accordance with 40 CFR 59, Subpart D (EPA Method 24), exclusive of colorants added to a tint base and water added at project site; or other method acceptable to authorities having jurisdiction.
- B. Chemical Content: The following compounds are prohibited:
 - 1. Aromatic Compounds: In excess of 1.0 percent by weight of total aromatic compounds (hydrocarbon compounds containing one or more benzene rings).
 - 2. Acrolein, acrylonitrile, antimony, benzene, butyl benzyl phthalate, cadmium, di (2-ethylhexyl) phthalate, di-n-butyl phthalate, di-n-octyl phthalate, 1,2-dichlorobenzene, diethyl phthalate., dimethyl phthalate, ethylbenzene, formaldehyde, hexavalent chromium, isophorone, lead, mercury, methyl ethyl ketone, methyl isobutyl ketone, methylene chloride, naphthalene, toluene (methylbenzene), 1,1,1-trichloroethane, vinyl chloride.
- C. Paints and Coatings: Where MPI product numbers are specified, provide products listed in Master Painters Institute Approved Product List, current edition available at www.paintinfo.com, for specified MPI Categories, except as otherwise indicated.
 - 1. Provide ready mixed paints and coatings , except field-catalyzed coatings.
 - 2. Do not dilute or thin coatings, except as instructed.
 - 3. Provide materials that are compatible with one another and the substrates indicated under conditions of service and application, as demonstrated by manufacturer based on testing and field experience.

- D. Accessory Materials: Linseed oil, shellac, turpentine, paint thinners and other materials not specifically indicated but required to achieve the finishes specified; commercial quality.

2.03 PAINT SYSTEMS

- A. Provide Premium Grade systems (2 top coats) as defined in MPI Architectural Painting Specification Manual, except as otherwise indicated.
- B. Where a specified paint system does not have a Premium Grade, provide Custom Grade system.

2.04 INTERIOR PAINT SYSTEMS

- A. Dressed Lumber:
 - 1. Applications include but are not limited to baseboards.
 - 2. INT 6.3Q W.B. Acrylic, Clear: W.B. Acrylic MPI #128, satin.
 - a. Compliant with the VOC requirements noted above.
- B. Wood Floors:
 - 1. INT 6.5C Polyurethane Varnish (Gloss): Polyurethane Varnish MPI #56, gloss.
 - a. Compliant with the VOC requirements noted above.
 - b. Minimum 4 coats.

PART 3 EXECUTION

3.01 EXAMINATION

- A. Verify that surfaces are ready to receive Work as instructed by the product manufacturer.
- B. Examine surfaces scheduled to be finished prior to commencement of work for surface imperfections and for contaminants which could impair performance or appearance of coatings, including but not limited to, loose primer, rust, scale, oil, grease, mildew, algae, or fungus, stains or marks, cracks, indentations, or abrasions. Report any condition that may potentially affect proper application.

3.02 PREPARATION

- A. Prepare surfaces as specified in MPI Architectural Painting Specification Manual and as follows for the applicable surface and coating; if multiple preparation treatments are specified, use as many as necessary for best results; where the Manual references external standards for preparation (e.g. SSPC standards), prepare as specified in those standards; comply with coating manufacturer's specific preparation methods or treatments, if any.
- B. Coordinate painting work with cleaning and preparation work so that dust and other contaminants do not fall on newly painted, wet surfaces.
- C. Surface Appurtenances: Prior to preparing surfaces or finishing, remove electrical plates, hardware, light fixtures, light fixture trim, escutcheons, machined surfaces, fittings, and similar items already installed that are not to be painted.
- D. New interior wood items to receive Transparent Finish: Wood should be clean and dry. Sand wood to obtain a uniform appearance before immediately starting work. Wipe off dust and grit prior to sealing, seal knots, pitch streaks, and sappy sections with sealer. Fill nail holes and cracks after sealer has dried; sand lightly between coats. Prime concealed surfaces with gloss varnish reduced 25 percent with thinner.
- E. Existing interior wood floors to receive Transparent Finish: Remove existing finish by sanding with commercial hardwood floor sanders, to a grit recommended by finish manufacturer. Fill imperfections in floor with compatible filler.

3.03 APPLICATION

- A. Apply products in accordance with manufacturer's instructions and as specified or recommended by MPI Manual, using the preparation, products, sheens, textures, and colors as indicated.
 - 1. Remove, refinish, or repaint work not complying with requirements.

- B. Use applicators and methods best suited for substrate and type of material being applied and according to manufacturer's instructions.
 - 1. Brush Application: Use brushes best suited for the type of material applied; use brush of appropriate size for the surface or item being painted; produce results free of visible brush marks.
 - 2. Roller Application: Use rollers of carpet, velvet back, or high-pile sheep's wool as recommended by manufacturer for material and texture required.
 - 3. Spray Application: Use airless spray equipment with orifice size as recommended by manufacturer for material and texture required.
 - 4. Where application method is listed in the MPI Manual for the paint system that application method is required; otherwise any application method recommended by manufacturer for material used and objects to be painted is acceptable.
- C. Shop finish running wall base and touch up filled fastener locations in the field.
- D. Concealed surfaces of running wall base should receive one coat of finish prior to installation.
- E. Minimum Coating Thickness: Apply paint materials no thinner than manufacturer's recommended spreading rate; provide total dry film thickness of entire system as recommended by manufacturer.
 - 1. Number of coats and film thickness required are the same regardless of application method.
 - 2. If undercoats, stains, or other conditions show through final coat of paint, apply additional coats until paint film is of uniform finish, color, and appearance.
 - 3. Give special attention to ensure edges, corners, crevices, welds, and exposed fasteners receive dry film thickness equivalent to that of flat surfaces.
- F. Apply finish to completely cover surfaces with uniform appearance without brush marks, roller marks, runs, sags, laps, ropiness, holidays, spotting, cloudiness, or other surface imperfections.
 - 1. Before applying finish coats, apply a prime coat of material recommended by manufacturer, unless the surface has been prime coated by others; where evidence of suction spots or unsealed areas in first coat appear, recoat primed and sealed surfaces to ensure finish coat with no burn through or other defects due to insufficient sealing.
 - 2. Apply first coat to surface that has been cleaned, pretreated, or otherwise prepared as soon as practical after preparation and before subsequent surface deterioration.
 - 3. Do not apply succeeding coats until the previous coat has cured as recommended by manufacturer.
 - 4. If manufacturer's instructions recommend sanding to produce a smooth, even surface, sand between coats.
 - 5. Before applying next coat vacuum clean surfaces of loose particles. Use tack cloth to remove dust and particles just prior to applying next coat.

3.04 CLEANING AND PROTECTION

- A. Collect waste material which may constitute a fire hazard, place in closed metal containers, and remove daily from site.
- B. At the end of each workday, remove empty cans, rags, rubbish, and other discarded paint materials from site.
- C. Protect other work, whether being painted or not, against damage by painting. Correct damage by cleaning, repairing or replacing, and repainting as approved by Architect.
- D. Provide "Wet Paint" signs to protect newly painted finishes. Remove temporary protective wrappings provided by others to protect their work after completing painting operations.
- E. At completion of construction activities of other trades, touch up and restore damaged or defaced painted surfaces. Comply with procedures specified in MPI Manual.

END OF SECTION

APPENDIX A

STRUCTURAL CALCULATIONS



**STRUCTURAL
SOURCE, LLC**

CONSULTING STRUCTURAL ENGINEERS

86705 Pine Grove Road, Eugene, OR 97402

Phone (541) 912-3958 / Fax (541) 343-3401

STRUCTURAL CALCULATIONS

GERLINGER HALL ANNEX BUILDING NEW DANCE FLOORING REVIEW

University of Oregon, Eugene, OR

Project Number 12-114



EXPIRES: 6/30/14

Prepared for

PIVOT Architecture,

July 2, 2012



**STRUCTURAL
SOURCE, LLC**
CONSULTING STRUCTURAL ENGINEERS

86705 Pine Grove Road, Eugene, OR 97402 (541) 912-3958 www.structural-source.com

**GERLINGER HALL ANNEX BUILDING
NEW DANCE FLOORING REVIEW**

University of Oregon, Eugene, OR

STRUCTURAL SUMMARY

Two existing dance halls on the upper floor of the Gerlinger Hall Annex Building are scheduled to have new sprung dance flooring systems installed. This system is comprised of 4'-0" x 8'-0" laminated composite sheets of flooring material set on small shock-absorbing pads. Structural Source was asked to review the impact that this new system would have on the existing upper floor framing and the building's lateral-load-resisting system.

Review of the existing floor framing confirmed that the existing deep glue-laminated beams are capable of supporting the additional load from the new flooring system without strengthening. It is likely that the beams were originally oversized to limit deflections and not sized simply for strength. See attached loads analysis and beam calculations for further information.

Weighing only 2.6 pounds per square foot, the new flooring system is so light relative to the existing floor dead loads that it is below the limit in the Oregon Structural Specialty Code that requires a seismic upgrade. Consequently, adding the new flooring may be done with no seismic strengthening.

Aside from the engineering items mentioned above, no further review of the building structure has been performed at this time.

Regards,



Kevin Wilger, S.E.

Principal
Structural Source, LLC

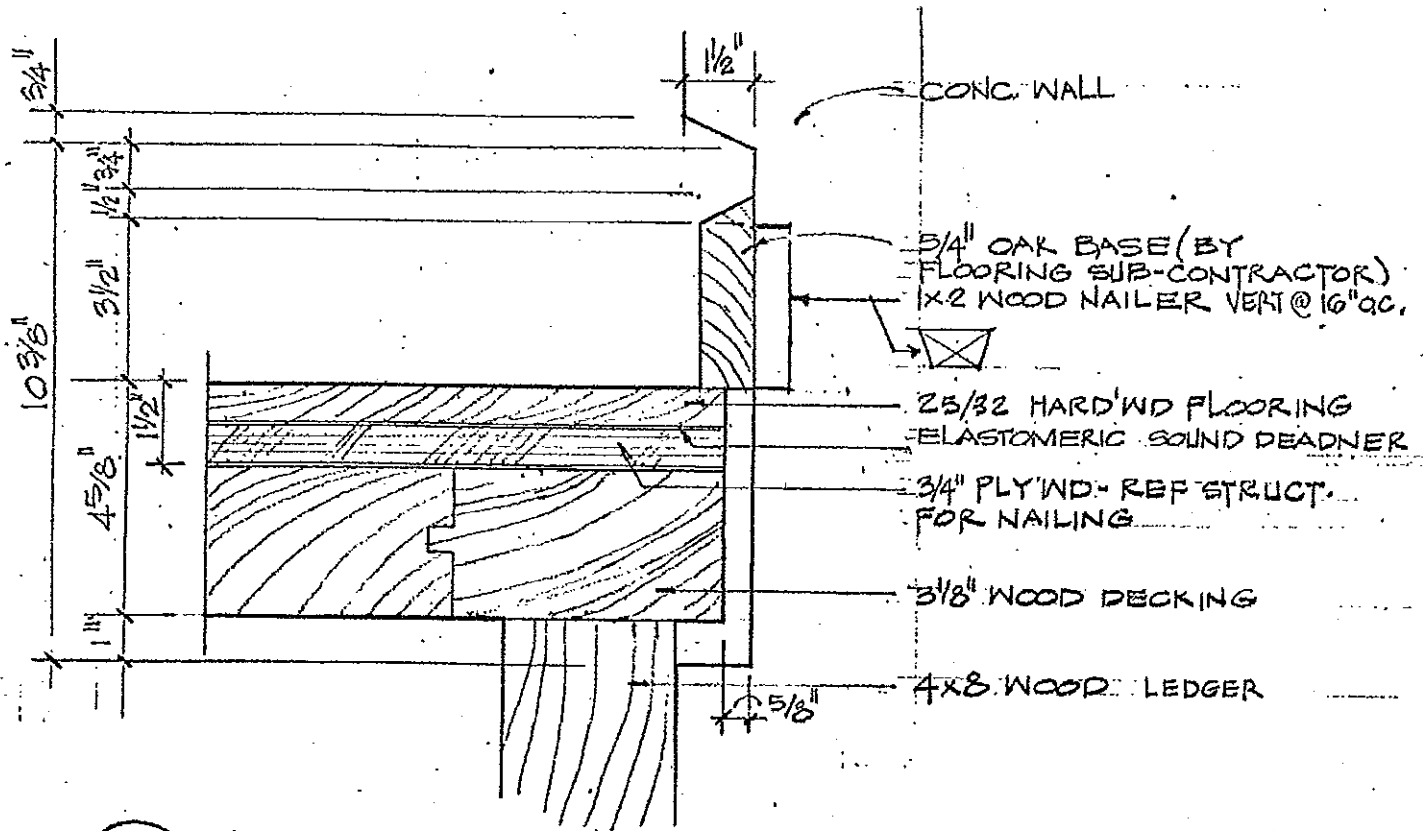

A UPPER LEVEL GYM FLOOR DETAIL ←

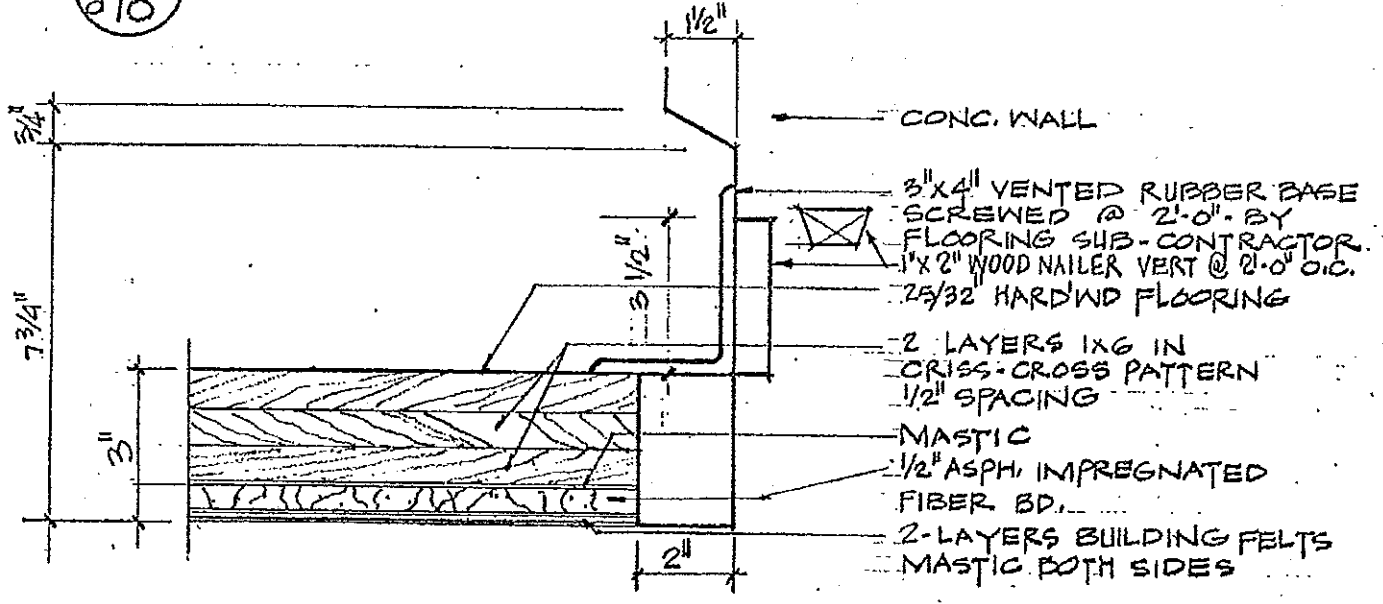

B LOWER LEVEL GYM FLOOR DETAIL
WATER STOP @ EXTERIOR WALLS OF GYM. 3/4" TO DTL. 1/8"

WOMEN'S PHYSICAL EDUCATION ADDITION UNIVERSITY OF OREGON Eugene, Oregon		GYM FLOOR DETAILS: SCALE 3" = 1'-0"	
ARCHITECTS: MORIN AND LONGWOOD		A I A	
70 EAST 14TH AVENUE EUGENE, OREGON		348-8401	
4-9-00197-0		DRAWN BEGGS	d 18
		APPROVED	
		DATE	
		COMM. NO. 0206	



STRUCTURAL SOURCE, LLC

www.structural-source.com

PROJECT :

PAGE NUMBER : 7

University of Oregon Gerlinger Hall

Dance Flooring Review

ENGINEER : KEW

DATE : 7/2/2012

VERTICAL DESIGN LOADS

EXISTING DEAD LOADS

SECOND FLOOR

25/32" HARDWOOD FLOORING	3.4 psf
3/4" PLYWOOD	2.5 psf
3 1/8" LAMINATED DECKING	9.5 psf
12 1/2" X 53 5/8" GLB'S AT 10'-0" O.C.	16.3 psf
TOTAL	31.7 psf

ADDED DEAD LOAD

SPRUNG DANCE FLOORING	2.6 psf
-----------------------	---------

LIVE LOADS from ASCE7-05 Table 4-1 (see attached)

DANCE HALLS AND BALLROOMS	100 psf
GYMNASIUM MAIN FLOORS	100 psf

SEISMIC LOADS

Since the weight of the new sprung flooring system is less than 10 percent of the existing floor dead loads, no seismic evaluation of the existing structure is required per the Exception in the Oregon Structural Specialty Code for Alterations under Section 3404.4 (see attached).

TABLE 4-1 MINIMUM UNIFORMLY DISTRIBUTED LIVE LOADS, L_o , AND MINIMUM CONCENTRATED LIVE LOADS

Occupancy or Use	Uniform psf (kN/m ²)	Conc. lb (kN)
Apartments (see <i>Residential</i>)		
Access floor systems		
Office use	50 (2.4)	2,000 (8.9)
Computer use	100 (4.79)	2,000 (8.9)
Armories and drill rooms	150 (7.18)	
Assembly areas and theaters		
Fixed seats (fastened to floor)	60 (2.87)	
Lobbies	100 (4.79)	
Movable seats	100 (4.79)	
Platforms (assembly)	100 (4.79)	
Stage floors	150 (7.18)	
Balconies (exterior)	100 (4.79)	
On one- and two-family residences only, and not exceeding 100 ft ² (9.3 m ²)	60 (2.87)	
Bowling alleys, poolrooms, and similar recreational areas	75 (3.59)	
Catwalks for maintenance access	40 (1.92)	300 (1.33)
Corridors		
First floor	100 (4.79)	
Other floors, same as occupancy served except as indicated		
Dance halls and ballrooms	100 (4.79)	
Decks (patio and roof)		
Same as area served, or for the type of occupancy accommodated		
Dining rooms and restaurants	100 (4.79)	
Dwellings (see <i>Residential</i>)		
Elevator machine room grating (on area of 4 in. ² [2,580 mm ²])		300 (1.33)
Finish light floor plate construction (on area of 1 in. ² [645 mm ²])		200 (0.89)
Fire escapes	100 (4.79)	
On single-family dwellings only	40 (1.92)	
Fixed ladders	See Section 4.4	
Garages (passenger vehicles only)	40 (1.92) ^{a,b}	
Trucks and buses		
Grandstands (see <i>Stadiums and arenas, Bleachers</i>)		
Gymnasiums—main floors and balconies	100 (4.79)	
Handrails, guardrails, and grab bars	See Section 4.4	
Hospitals		
Operating rooms, laboratories	60 (2.87)	1,000 (4.45)
Patient rooms	40 (1.92)	1,000 (4.45)
Corridors above first floor	80 (3.83)	1,000 (4.45)
Hotels (see <i>Residential</i>)		
Libraries		
Reading rooms	60 (2.87)	1,000 (4.45)
Stack rooms	150 (7.18) ^c	1,000 (4.45)
Corridors above first floor	80 (3.83)	1,000 (4.45)
Manufacturing		
Light	125 (6.00)	2,000 (8.90)
Heavy	250 (11.97)	3,000 (13.40)
Marquees	75 (3.59)	
Office Buildings		
File and computer rooms shall be designed for heavier loads based on anticipated occupancy		
Lobbies and first-floor corridors	100 (4.79)	2,000 (8.90)
Offices	50 (2.40)	2,000 (8.90)
Corridors above first floor	80 (3.83)	2,000 (8.90)
Penal Institutions		
Cell blocks	40 (1.92)	
Corridors	100 (4.79)	
Residential		
Dwellings (one- and two-family)		
Uninhabitable attics without storage	10 (0.48)	
Uninhabitable attics with storage	20 (0.96)	
Habitable attics and sleeping areas	30 (1.44)	
All other areas except stairs and balconies	40 (1.92)	
Hotels and multifamily houses		
Private rooms and corridors serving them	40 (1.92)	
Public rooms and corridors serving them	100 (4.79)	
Reviewing stands, grandstands, and bleachers	100 (4.79) ^d	

EXISTING STRUCTURES

3403.3 Existing structural elements carrying gravity load.

Any existing gravity load-carrying structural element for which an *addition* and its related alterations cause an increase in design gravity load of more than 5 percent shall be strengthened, supplemented, replaced or otherwise altered as needed to carry the increased load required by this code for new structures. Any existing gravity load-carrying structural element whose gravity load-carrying capacity is decreased shall be considered an altered element subject to the requirements of Section 3404.3. Any existing element that will form part of the lateral load path for any part of the *addition* shall be considered an existing lateral load-carrying structural element subject to the requirements of Section 3403.4.

3403.3.1 Design live load. Where the *addition* does not result in increased design live load, existing gravity load-carrying structural elements shall be permitted to be evaluated and designed for live loads *approved* prior to the *addition*. If the *approved* live load is less than that required by Section 1607, the area designed for the nonconforming live load shall be posted with placards of *approved* design indicating the *approved* live load. Where the *addition* does result in increased design live load, the live load required by Section 1607 shall be used.

3403.4 Existing structural elements carrying lateral load. Where the *addition* is structurally independent of the *existing structure*, existing lateral load-carrying structural elements shall be permitted to remain unaltered. Where the *addition* is not structurally independent of the *existing structure*, the *existing structure* and its *addition* acting together as a single structure shall be shown to meet the requirements of Sections 1609 and 1613.

Exception: Any existing lateral load-carrying structural element whose demand-capacity ratio with the *addition* considered is no more than 10 percent greater than its demand-capacity ratio with the *addition* ignored shall be permitted to remain unaltered. For purposes of calculating demand-capacity ratios, the demand shall consider applicable load combinations with design lateral loads or forces in accordance with Sections 1609 and 1613. For purposes of this exception, comparisons of demand-capacity ratios and calculation of design lateral loads, forces and capacities shall account for the cumulative effects of additions and alterations since original construction.

3403.4.1 Seismic. Seismic requirements for alterations shall be in accordance with this section. Where the existing seismic force-resisting system is a type that can be designated ordinary, values of R , Ω_0 and C_d for the existing seismic force-resisting system shall be those specified by this code for an ordinary system unless it is demonstrated that the existing system will provide performance equivalent to that of a detailed intermediate or special system.

SECTION 3404 ALTERATIONS

3404.1 General. Except as provided by Section 3401.4 or this section, alterations to any building or structure shall comply with the requirements of the code for new construction. Alter-

ations shall be such that the existing building or structure is no less complying with the provisions of this code than the existing building or structure was prior to the *alteration*.

Exceptions:

1. An existing *stairway* shall not be required to comply with the requirements of Section 1009 where the existing space and construction does not allow a reduction in pitch or slope.
2. Handrails otherwise required to comply with Section 1009.12 shall not be required to comply with the requirements of Section 1012.6 regarding full extension of the handrails where such extensions would be hazardous due to plan configuration.

3404.2 Flood hazard areas. For buildings and structures in flood hazard areas established in Section 1612.3, any *alteration* that constitutes substantial improvement of the existing structure, as defined in Section 1612.2, shall comply with the flood design requirements for new construction, and all aspects of the *existing structure* shall be brought into compliance with the requirements for new construction for flood design.

For buildings and structures in flood hazard areas established in Section 1612.3, any alterations that do not constitute substantial improvement or substantial damage of the existing structure, as defined in Section 1612.2, are not required to comply with the flood design requirements for new construction.

3404.3 Existing structural elements carrying gravity load. Any existing gravity load-carrying structural element for which an *alteration* causes an increase in design gravity load of more than 5 percent shall be strengthened, supplemented, replaced or otherwise altered as needed to carry the increased gravity load required by this code for new structures. Any existing gravity load-carrying structural element whose gravity load-carrying capacity is decreased as part of the *alteration* shall be shown to have the capacity to resist the applicable design gravity loads required by this code for new structures.

3404.3.1 Design live load. Where the *alteration* does not result in increased design live load, existing gravity load-carrying structural elements shall be permitted to be evaluated and designed for live loads *approved* prior to the *alteration*. If the *approved* live load is less than that required by Section 1607, the area designed for the nonconforming live load shall be posted with placards of *approved* design indicating the *approved* live load. Where the *alteration* does result in increased design live load, the live load required by Section 1607 shall be used.

3404.4 Existing structural elements carrying lateral load. Except as permitted by Section 3404.5, where the *alteration* increases design lateral loads in accordance with Section 1609 or 1613, or where the *alteration* results in a structural irregularity as defined in ASCE 7, or where the *alteration* decreases the capacity of any existing lateral load-carrying structural element, the structure of the altered building or structure shall be shown to meet the requirements of Sections 1609 and 1613.

Exception: Any existing lateral load-carrying structural element whose demand-capacity ratio with the *alteration* considered is no more than 10 percent greater than its demand-capacity ratio with the *alteration* ignored shall be

permitted to remain unaltered. For purposes of calculating demand-capacity ratios, the demand shall consider applicable load combinations with design lateral loads or forces per Sections 1609 and 1613. For purposes of this exception, comparisons of demand-capacity ratios and calculation of design lateral loads, forces, and capacities shall account for the cumulative effects of additions and alterations since original construction.

3404.4.1 Seismic. Seismic requirements for alterations shall be in accordance with this section. Where the existing seismic force-resisting system is a type that can be designated ordinary, values of R , Ω_0 and C_d for the existing seismic force-resisting system shall be those specified by this code for an ordinary system unless it is demonstrated that the existing system will provide performance equivalent to that of a detailed intermediate or special system.

3404.5 Voluntary seismic improvements. Alterations to existing structural elements or additions of new structural elements that are not otherwise required by this chapter and are initiated for the purpose of improving the performance of the seismic force-resisting system of an *existing structure* or the performance of seismic bracing or anchorage of existing nonstructural elements shall be permitted, provided that an engineering analysis is submitted demonstrating the following:

1. The altered structure and the altered nonstructural elements are no less in compliance with the provisions of this code with respect to earthquake design than they were prior to the *alteration*.
2. New structural elements are detailed and connected to the existing structural elements as required by Chapter 16.
3. New or relocated nonstructural elements are detailed and connected to existing or new structural elements as required by Chapter 16.
4. The alterations do not create a structural irregularity as defined in ASCE 7 or make an existing structural irregularity more severe.

3404.6 Means of egress capacity factors. Alterations to any existing building or structure shall not be affected by the egress width factors in Section 1005.1 for new construction in determining the minimum egress widths or the minimum number of exits in an existing building or structure. The minimum egress widths for the components of the *means of egress* shall be based on the *means of egress* width factors in the building code under which the building was constructed, and shall be considered as complying *means of egress* for any *alteration* if, in the opinion of the building code official, they do not constitute a distinct hazard to life.

SECTION 3405 REPAIRS

3405.1 General. Buildings and structures, and parts thereof, shall be repaired in compliance with Section 3401.2. Work on nondamaged components that is necessary for the required repair of damaged components shall be considered part of the repair and shall not be subject to the requirements for alter-

ations in this chapter. Routine maintenance required by Section 3401.2, ordinary repairs exempt from *permit* in accordance with Section 105.2, and abatement of wear due to normal service conditions shall not be subject to the requirements for repairs in this section.

3405.1.1 Dangerous conditions. Regardless of the extent of structural or nonstructural damage, the building code official shall have the authority to require the elimination of conditions deemed dangerous.

3405.2 Substantial structural damage to vertical elements of the lateral force-resisting system. A building that has sustained substantial structural damage to the vertical elements of its lateral force-resisting system shall be evaluated and repaired in accordance with the applicable provisions of Sections 3405.2.1 through 3405.2.3.

3405.2.1 Evaluation. The building shall be evaluated by a *registered design professional*, and the evaluation findings shall be submitted to the code official. The evaluation shall establish whether the damaged building, if repaired to its predamage state, would comply with the provisions of this code for wind and earthquake loads. Evaluation for earthquake loads shall be required if the substantial structural damage was caused by or related to earthquake effects or if the building is in Seismic Design Category C, D, E or F.

Wind loads for this evaluation shall be those prescribed in Section 1609. Earthquake loads for this evaluation, if required, shall be permitted to be 75 percent of those prescribed in Section 1613. Values of R , W_0 and C_d for the existing seismic force-resisting system shall be those specified by this code for an ordinary system unless it is demonstrated that the existing system will provide performance equivalent to that of an intermediate or special system.

3405.2.2 Extent of repair for compliant buildings. If the evaluation establishes compliance of the predamage building in accordance with Section 3405.2.1, then repairs shall be in accordance with the *Building Code* for new construction.

3405.2.3 Extent of repair for noncompliant buildings. If the evaluation does not establish compliance of the predamage building in accordance with Section 3405.2.1, then the building shall be rehabilitated to comply with applicable provisions of this code for load combinations, including wind or seismic loads. New structural members and connections required by this rehabilitation design shall comply with the provisions of this code for new buildings of similar structure, purpose and location.

3405.3 Substantial structural damage to gravity load-carrying components. Gravity load-carrying components that have sustained substantial structural damage shall be rehabilitated to comply with the applicable provisions of this code for gravity loads. Nondamaged gravity load-carrying components that receive dead, live or snow loads from rehabilitated components shall also be rehabilitated or shown to have the capacity to carry the design loads of the rehabilitation design. New structural members and connections required by this rehabilitation design shall comply with the provisions of this code for new buildings of similar structure, purpose and location.



CHECK EXISTING $12\frac{1}{2}'' \times 53\frac{5}{8}''$ GLB'S

$$SPAN = (79'-2'') - (2(1'-2'')/2)$$

$$= 78.0'$$

↳ HORIZ DIM OF BM SEAT

TRIB. AREA

$$= 78.0'(10') = 780\text{ ft}^2 > 650\text{ ft}^2 \therefore \text{LL RED} = 70\%$$

REDUCED LIVE LOAD

$$= 100\text{ PSF} (0.60) = 60\text{ PSF}$$

TOTAL UNIF. LD

$$= (60\text{ PSF} + 34.3\text{ PSF}) 10'$$

$$= 943\text{ PLF}$$

$$M = 0.943\text{ KLF} (78.0')^2 / 8$$

$$= 717'\text{K}$$

$$V = 0.943\text{ KLF} (78.0'(0.5) - 4.47'(0.5))$$

$$= 34.8\text{ K}$$

Mallow = $S C_p F_b$

$$= 599\text{ in}^3 (0.847) 2.4\text{ ksi} / 12$$

$$= 1015'\text{K} > 717'\text{K}$$

Vallow = $A F_v (2/3)$

$$= 670\text{ in}^2 (165\text{ psi}) (2/3) / 1000$$

$$= 73.7\text{ K} > 34.8\text{ K}$$

EXISTING GLB'S ARE OK

OWNER

University of Oregon
 1295 Franklin Blvd.
 1276 University of Oregon
 Eugene, OR 97403-1276
 Contact: Bruce Budzik, Project Manager, Capital Construction
 (541) 346-5276
 bbbudzik@uoregon.edu

ARCHITECT

PIVOT Architecture
 44 West Broadway, Suite 300
 Eugene, OR 97401
 Contact: Larry Banks, AIA
 (541) 342-7291

UNIVERSITY of OREGON

**GERLINGER HALL ANNEX
 DANCE FLOOR INSTALLATION PROJECT**

1276 UNIVERSITY of OREGON, EUGENE, OREGON, 97403

09.05.2012 BID SET



VICINITY MAP

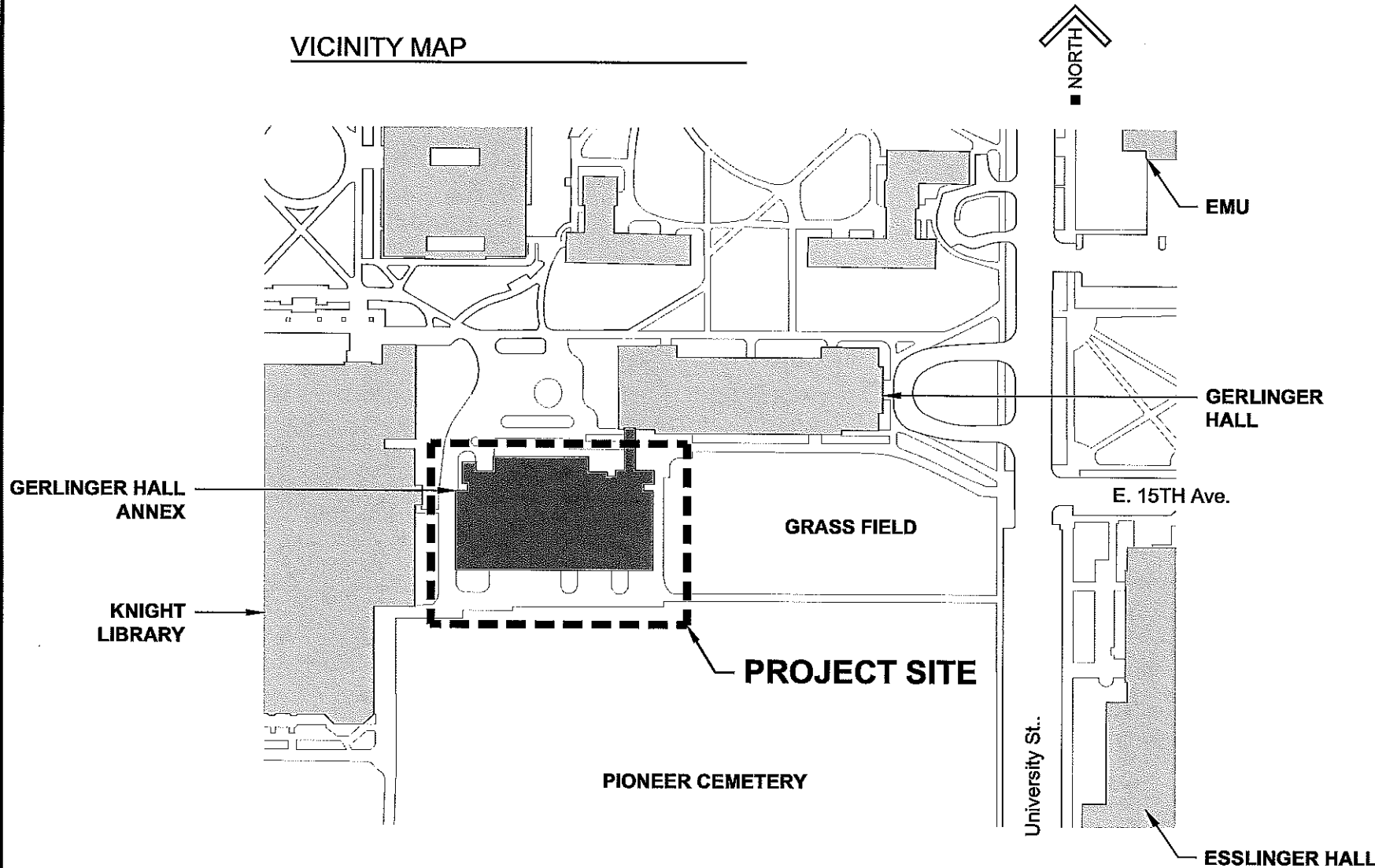

SHEET INDEX

TITLE	TITLE SHEET
A001	SITE / STAGING PLAN, SYMBOLS
A101	3RD FLOOR PLAN
A102	ENLARGED PLANS, DETAILS
A103	DETAILS

UNIVERSITY OF OREGON
 GERLINGER ANNEX
 DANCE FLOOR INSTALLATION PROJECT

PROJECT #:	1221.00	LB
DATE:	09.05.12	LB
DRAWN:	LB	CHECK:
TITLE		

GENERAL NOTES

- A. WORK AND STAGING ACTIVITIES TO BE LIMITED TO PROJECT LIMITS AREA.
- B. PROVIDE UNRESTRICTED ACCESS TO AND FROM ENTRY DOORS AT ALL TIMES, EXCEPT WHEN ALTERNATIVE ROUTE(S) ARE COORDINATED WITH OWNER.
- C. LIMIT DAMAGE TO (E) LANDSCAPING. REPAIR AND / OR REPLACE ALL DAMAGE AT THE END OF CONSTRUCTION.
- D. CONTRACTOR TO OBTAIN PARKING PASSES AT OWN EXPENSE. PASSES CAN BE PURCHASED AT DEPARTMENT OF PUBLIC SAFETY AT 1319 E. 15TH AVE. 541-346-5444.
- E. LIMITED ACCESS IS AVAILABLE AT THE NE CORNER OF THE BUILDING, COORDINATE WITH THE OWNER'S PROJECT MANAGER.

ABBREVIATIONS

@	AT
AFF	ABOVE FINISH FLOOR
BTWN	BETWEEN
BLDG	BUILDING
CLR	CLEAR
CONT	CONTINUOUS
DN	DOWN
DTL	DETAIL
DWG	DRAWING
(E)	EXISTING
EA	EACH
MAX	MAXIMUM
MFR	MANUFACTURER
MIN	MINIMUM
MISC	MISCELLANEOUS
NTS	NOT TO SCALE
OC	ON CENTER
OFCI	OWNER FURNISHED CONTRACTOR INSTALLED
OFOI	OWNER FURNISHED OWNER INSTALLED
OH	OPPOSITE HAND
OPP	OPPOSITE
PT	PRESSURE TREATED
PLY	PLYWOOD
SHT	SHEET
SIM	SIMILAR
SPECS	SPECIFICATIONS
SQFT, SF	SQUARE FOOT
S STL	STAINLESS STEEL
STD	STANDARD
STL	STEEL
T&G	TONGUE & GROOVE
TO	TOP OF
TOC	TOP OF CONCRETE
TOF	TOP OF FOUNDATION
TOW	TOP OF WALL
TOS	TOP OF STRUCTURE
TYP	TYPICAL
UNO	UNLESS NOTED OTHERWISE
VFY	VERIFY

SYMBOLS

	KEYNOTE
	ROOM NAME AND NUMBER
	DETAIL BUBBLE

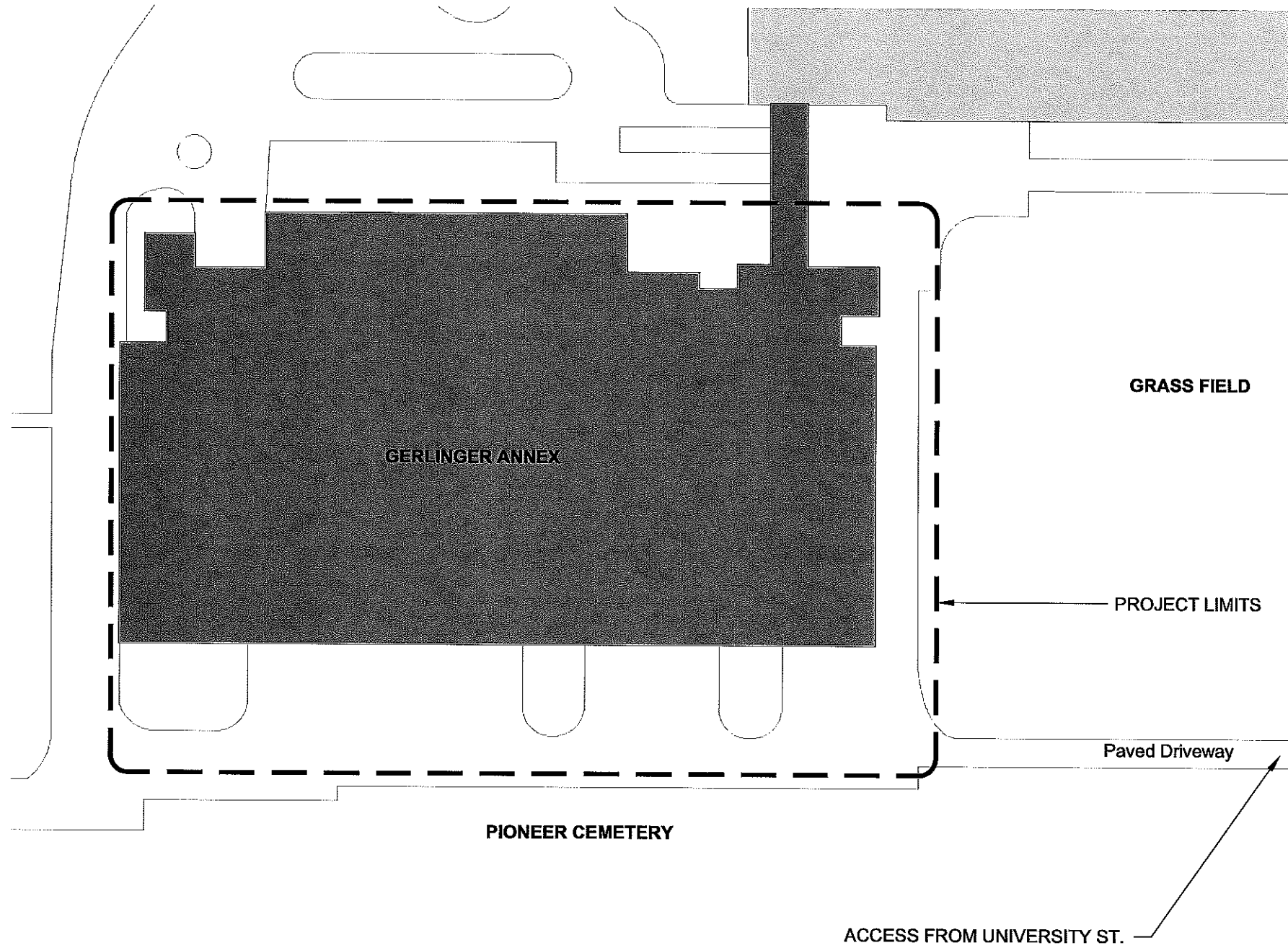

1 SITE / STAGING PLAN

1" = 40'-0"



UNIVERSITY OF OREGON
GERLINGER ANNEX
DANCE FLOOR INSTALLATION PROJECT

PROJECT #:	1221.00	LB
DATE:	09.05.12	LB
DRAWN:		LB
CHECK:		LB

A001

GENERAL NOTES - THIS SHEET

- A. PROTECT ALL EXISTING SURFACES (INCLUDING CURTAINS, WOOD WALL PANELS, ADJACENT FLOORING) FROM DAMAGE DUE TO WORK OF THIS CONTRACT.

KEYNOTES - THIS SHEET

- ① DEMOLITION: REMOVE (E) WOOD BASE FROM ALL WALLS IN ROOMS 350 & 352, INCLUDING AREAS NEAR DOORS WHERE (E) FLOORING REMAINS.
- ② AREA OF NEW WOOD DANCE FLOORING. 
- ③ PROVIDE NEW WOOD BASE ON ALL WALLS OF ROOMS 350 & 352 TO REPLACE (E).
- ④ TRIM EXISTING WOOD DOOR BOTTOM TO PROVIDE 3/4" CLEARANCE ABOVE NEW WOOD FLOOR. SEAL CUT EDGE WITH 2 COATS NO-VOC POLYURETHANE (TYP. OF 8 DOORS).
- ⑤ AT (E) DOORS, REMOVE (E) STEEL THRESHOLD AS REQUIRED FOR DANCE FLOOR INSTALLATION.
- ⑥ AREA OF NEW (OFCI) VINYL PERFORMANCE SURFACE IN ROOM 350, UP TO WALLS AND TRANSITION EDGES, CONFIRM SEAM DIRECTION WITH OWNER.
- ⑦ AREA OF REMOVED AND RE-INSTALLED (OFCI) (E) VINYL PERFORMANCE SURFACE IN ROOM 352, CONFIRM EXACT BOUNDARY AND SEAM DIRECTION WITH OWNER.

STAIRS FOR CONSTRUCTION USE
ELEVATOR FOR CONSTRUCTION USE; 2100 LB. CAPACITY; OWNER WILL PROVIDE WALL PADS FOR USE DURING WORK

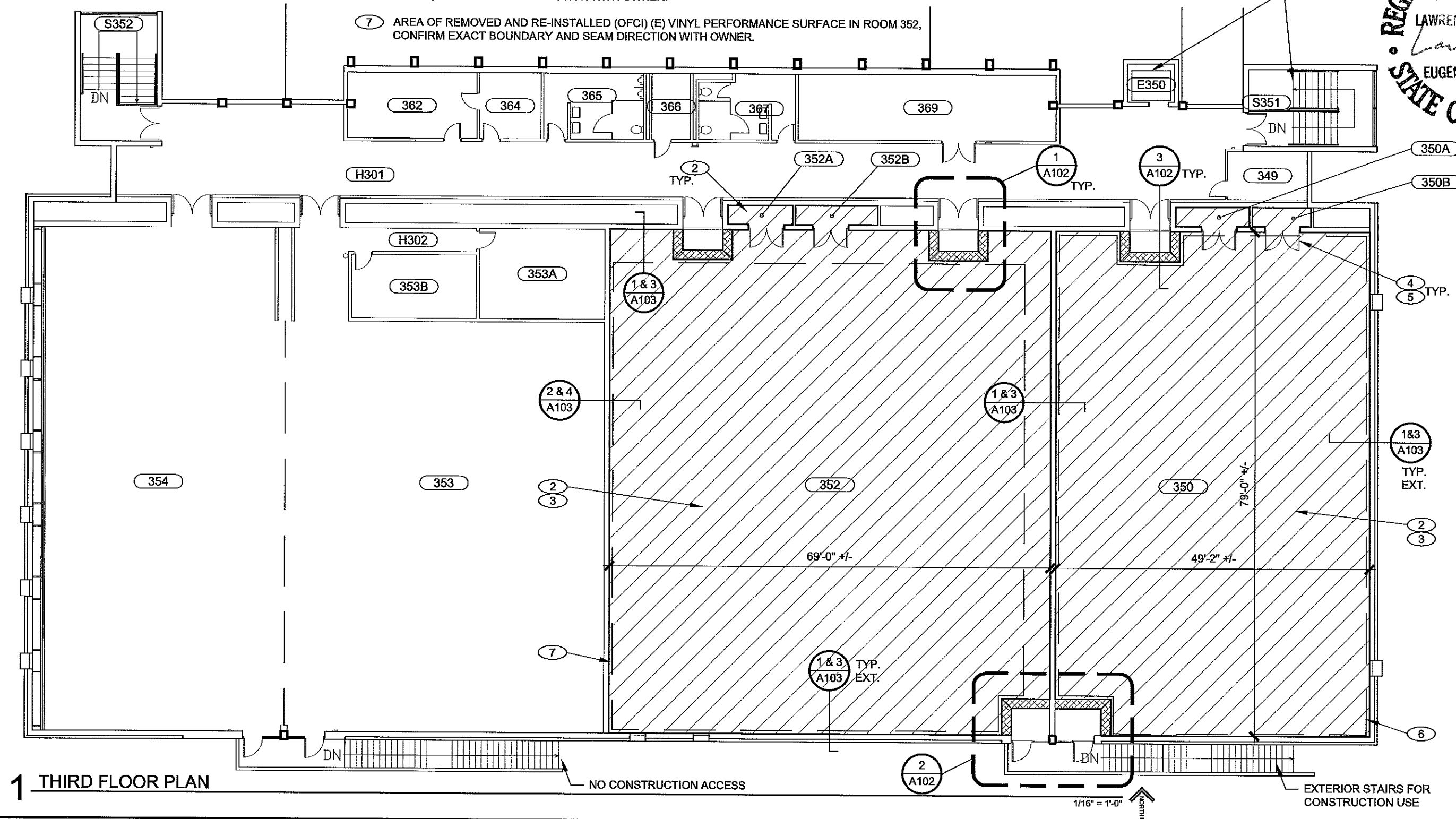

1 THIRD FLOOR PLAN

UNIVERSITY OF OREGON
GERLINGER ANNEX
DANCE FLOOR INSTALLATION PROJECT

PROJECT #:	1221.00	LB
DATE:	09.05.12	LB
DRAWN:	LB	CHECK: LB
A101		

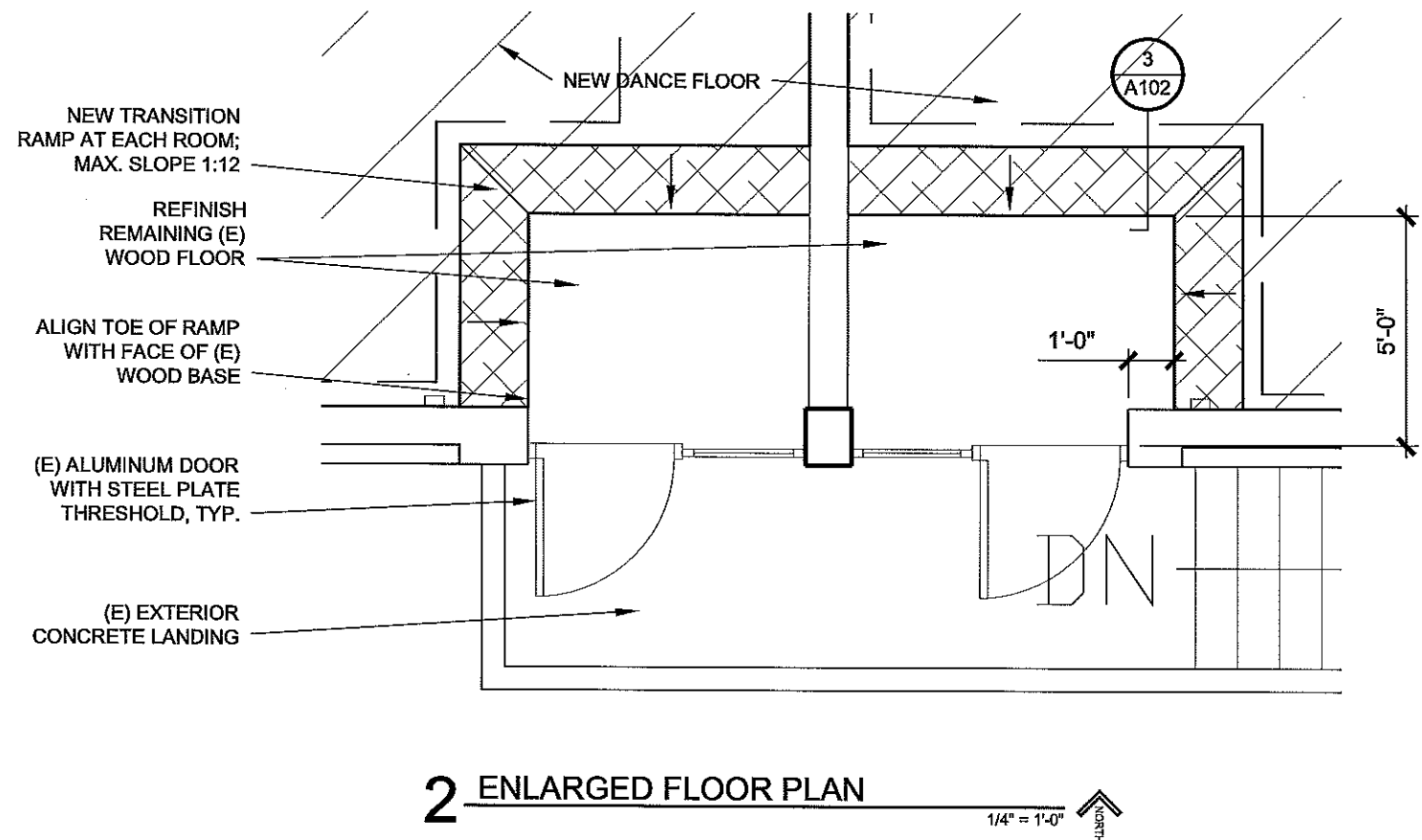
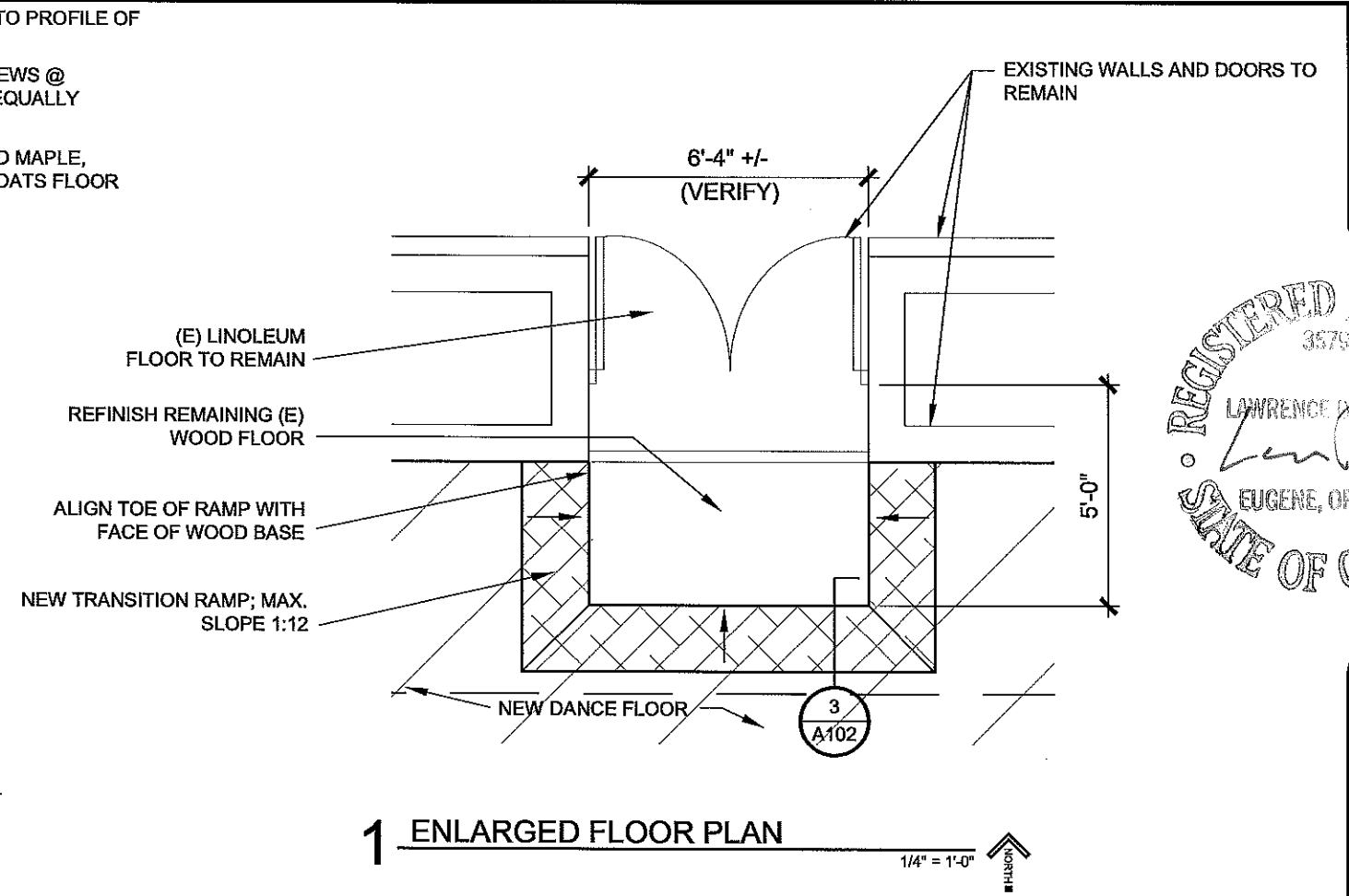
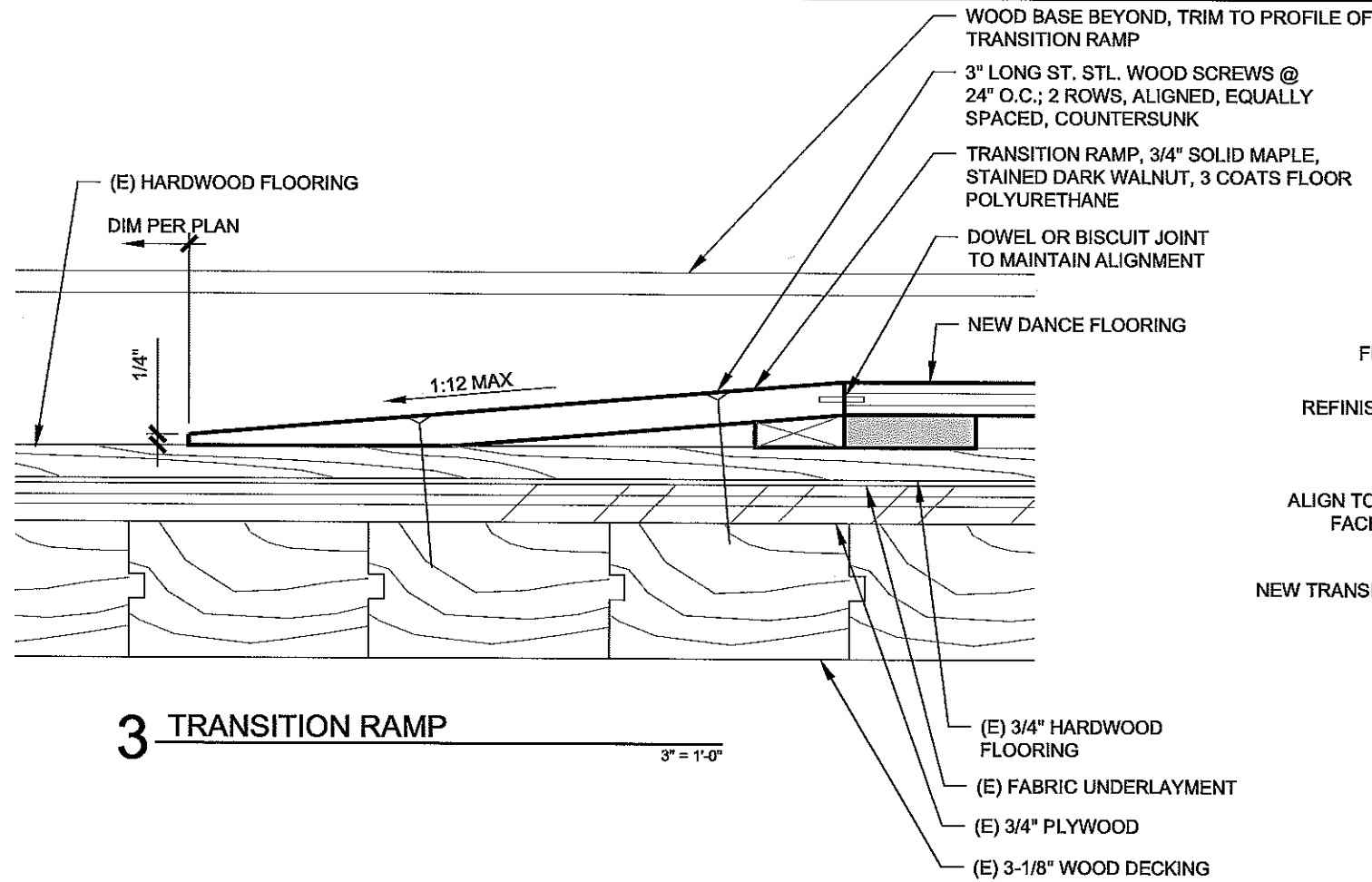

UNIVERSITY OF OREGON
GERLINGER ANNEX
DANCE FLOOR INSTALLATION PROJECT

PROJECT #	1221.00	LB
DATE	09.05.12	CHECK
DRAWN	LB	LB
A102		

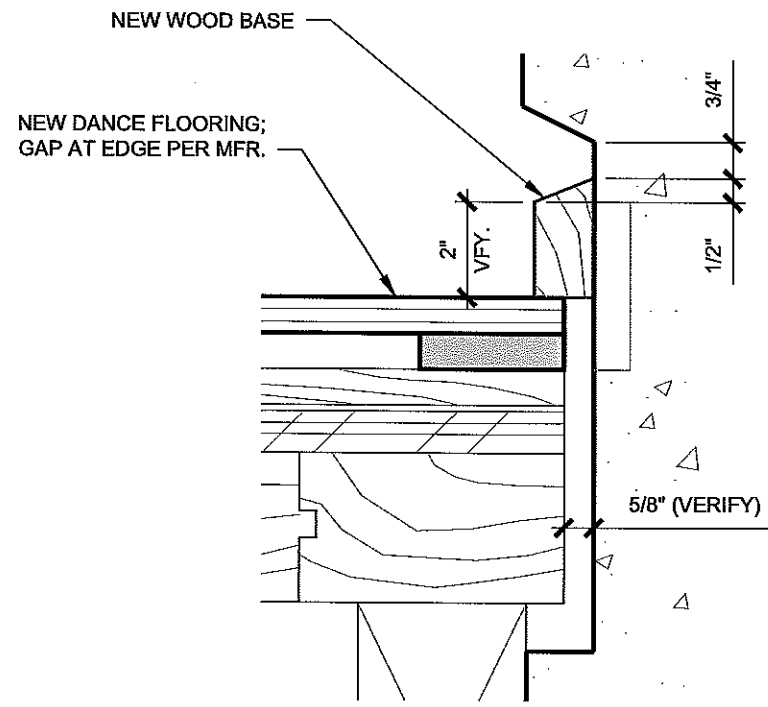

3 FLOOR / BASE DETAIL - NEW
3" = 1'-0"

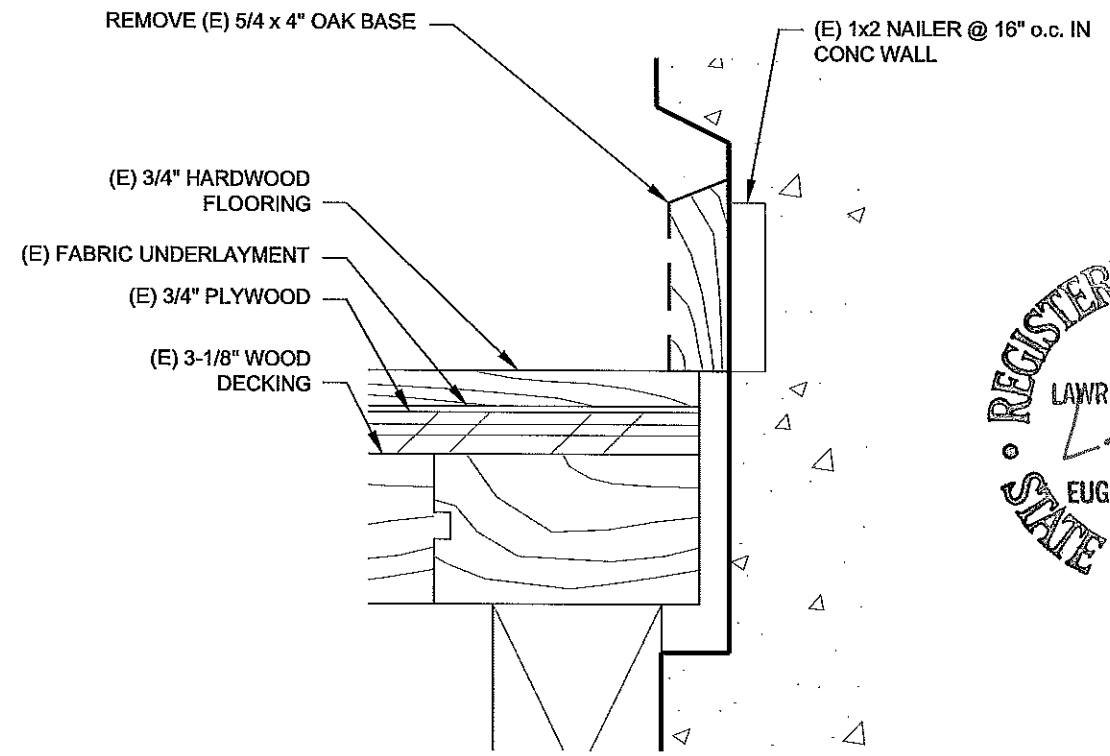

1 FLOOR / BASE DETAIL - DEMO
3" = 1'-0"

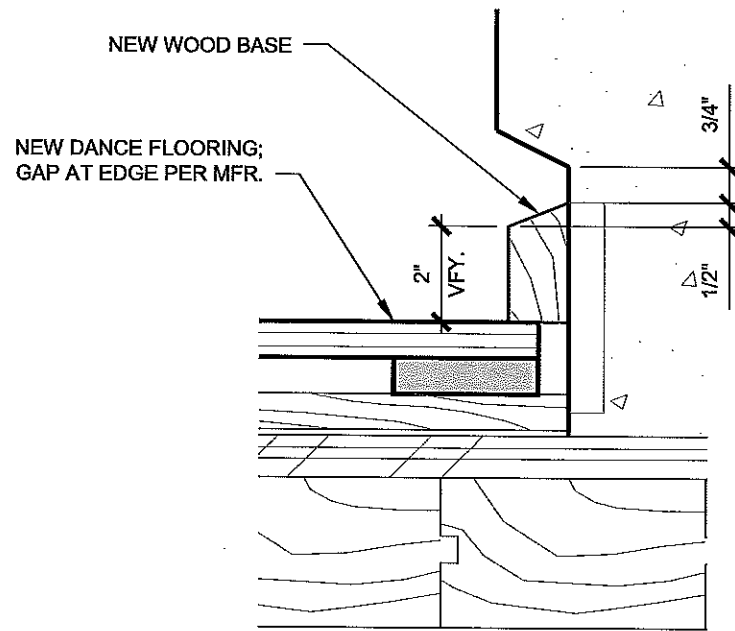

4 FLOOR / BASE DETAIL - NEW
3" = 1'-0"

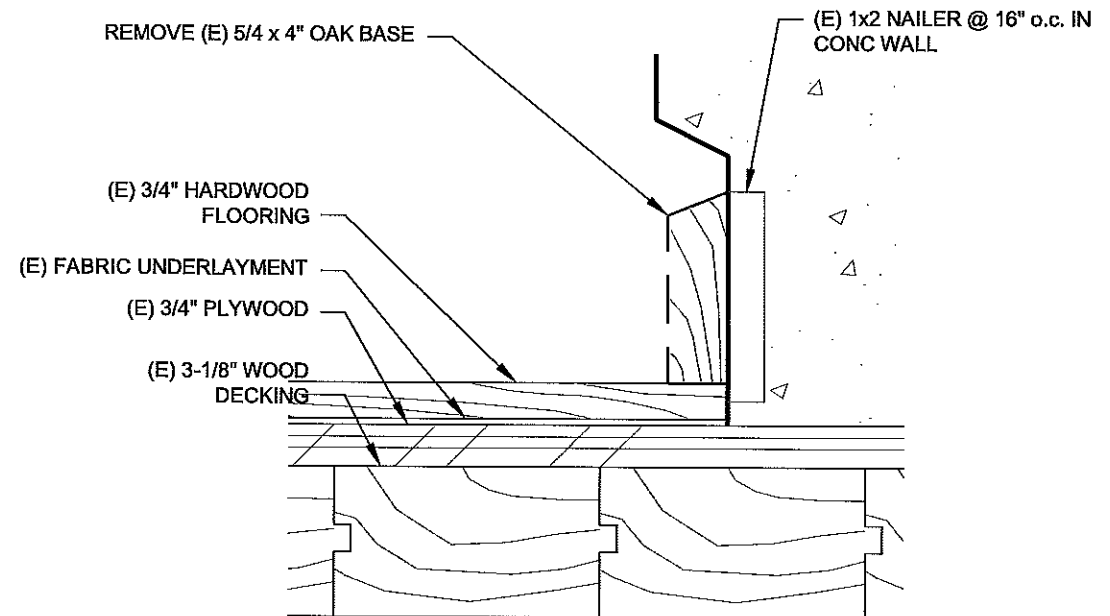

2 FLOOR / BASE DETAIL - DEMO
3" = 1'-0"